

# **TFT COLOR LCD MODULE**

**NL192108AC18-02D**

**40cm (15.6 Type)**

**FHD**

**LVDS interface (2 ports)**

**DATA SHEET**

**DOD-PP-3095 (2nd edition)**

**This DATA SHEET is updated document from  
DATA SHEET DOD-PP-2571(1)**

**All information is subject to change without notice.  
Please confirm the sales representative before  
starting to design your system.**

---

## INTRODUCTION

The Copyright to this document belongs to Tianma Japan, Ltd. (hereinafter called "TMJ"). No part of this document will be used, reproduced or copied without prior written consent of TMJ.

TMJ does and will not assume any liability for infringement of patents, copyrights or other intellectual property rights of any third party arising out of or in connection with application of the products described herein except for that directly attributable to mechanisms and workmanship thereof. No license, express or implied, is granted under any patent, copyright or other intellectual property right of TMJ.

Some electronic products would fail or malfunction at a certain rate. In spite of every effort to enhance reliability of products by TMJ, the possibility of failures and malfunction might not be avoided entirely. To prevent the risks of damage to death, human bodily injury or other property arising out thereof or in connection therewith, each customer is required to take sufficient measures in its safety designs and plans including, but not limited to, redundant system, fire-containment and anti-failure.

The products are classified into three grades: "**Standard**", "**Special**", and "**Specific**".

Each quality grade is designed for applications described below. Any customer who intends to use a product for application other than that of Standard is required to contact TMJ sales representative in advance.

The **Standard**: Applications as any failure, malfunction or error of the products are free from any damage to death, human bodily injury or other property (Products Safety Issue) and not related the safety of the public (Social Issues), like general electric devices.

Examples: Office equipment, audio and visual equipment, communication equipment, test and measurement equipment, personal electronic equipment, home electronic appliances, car navigation system (with no vehicle control functions), seat entertainment monitor for vehicles and airplanes, fish finder (except marine radar integrated type), PDA, etc.

The **Special**: Applications as any failure, malfunction or error of the products might directly cause any damage to death, human bodily injury or other property (Products Safety Issue) and the safety of the public (Social Issues) and required high level reliability by conventional wisdom.

Examples: Vehicle/train/ship control system, traffic signals system, traffic information control system, air traffic control system, surgery/operation equipment monitor, disaster/crime prevention system, etc.

The **Specific**: Applications as any failure, malfunction or error of the products might severe cause any damage to death, human bodily injury or other property (Products Safety Issue) and the safety of the public (Social Issues) and developed, designed and manufactured in accordance with the standards or quality assurance program designated by the customer who requires extremely high level reliability and quality.

Examples: Aerospace system (except seat entertainment monitor), nuclear control system, life support system, etc.

The quality grade of this product is the "**Standard**" unless otherwise specified in this document.

## CONTENTS

<b>INTRODUCTION .....</b>	<b>2</b>
<b>1. OUTLINE.....</b>	<b>4</b>
1.1 STRUCTURE AND PRINCIPLE .....	4
1.2 APPLICATION .....	4
1.3 FEATURES .....	4
<b>2. GENERAL SPECIFICATIONS.....</b>	<b>5</b>
<b>3. BLOCK DIAGRAM.....</b>	<b>6</b>
<b>4. DETAILED SPECIFICATIONS.....</b>	<b>7</b>
4.1 MECHANICAL SPECIFICATIONS .....	7
4.2 ABSOLUTE MAXIMUM RATINGS.....	7
4.3 ELECTRICAL CHARACTERISTICS.....	8
4.3.1 LCD panel signal processing board.....	8
4.3.2 LED driver .....	9
4.3.3 Fuse.....	9
4.4 POWER SUPPLY VOLTAGE SEQUENCE.....	10
4.4.1 LCD panel signal processing board.....	10
4.4.2 LED driver .....	11
4.5 CONNECTIONS AND FUNCTIONS FOR INTERFACE PINS.....	12
4.5.1 LCD panel signal processing board.....	12
4.5.2 LED driver .....	13
4.5.3 Positions of socket.....	13
4.5.4 Input data mapping .....	14
4.6 DISPLAY COLORS AND INPUT DATA SIGNALS.....	15
4.7 DISPLAY POSITIONS .....	16
4.8 INPUT SIGNAL TIMINGS .....	17
4.8.1 Outline of input signal timings .....	17
4.8.2 Timing characteristics.....	18
4.8.3 Input signal timing chart.....	19
4.9 LVDS Rx AC SPEC .....	20
4.10 OPTICS.....	21
4.10.1 Optical characteristics.....	21
4.10.2 Definition of contrast ratio.....	22
4.10.3 Definition of luminance uniformity .....	22
4.10.4 Definition of response times .....	22
4.10.5 Definition of viewing angles.....	22
<b>5. ESTIMATED LUMINANCE LIFETIME.....</b>	<b>23</b>
<b>6. RELIABILITY TESTS .....</b>	<b>24</b>
<b>7. PRECAUTIONS .....</b>	<b>25</b>
7.1 MEANING OF CAUTION SIGNS .....	25
7.2 CAUTIONS .....	25
7.3 ATTENTIONS.....	25
7.3.1 Handling of the product .....	25
7.3.2 Environment.....	26
7.3.3 Characteristics.....	26
7.3.4 Others.....	27
<b>8. OUTLINE DRAWINGS.....</b>	<b>28</b>
8.1 FRONT VIEW .....	28
8.2 REAR VIEW .....	29

## 1. OUTLINE

### 1.1 STRUCTURE AND PRINCIPLE

Color LCD module NL192108AC18-02D is composed of the amorphous silicon thin film transistor liquid crystal display (a-Si TFT LCD) panel structure with driver LSIs for driving the TFT (Thin Film Transistor) array and a backlight.

The a-Si TFT LCD panel structure is injected liquid crystal material into a narrow gap between the TFT array glass substrate and a color-filter glass substrate.

Color (Red, Green, Blue) data signals from a host system (e.g. signal generator, etc.) are modulated into best form for active matrix system by a signal processing board, and sent to the driver LSIs which drive the individual TFT arrays.

The TFT array as an electro-optical switch regulates the amount of transmitted light from the backlight assembly, when it is controlled by data signals. Color images are created by regulating the amount of transmitted light through the TFT array of red, green and blue dots.

### 1.2 APPLICATION

- For industrial use

### 1.3 FEATURES



- Ultra-Wide viewing angle (Super Fine TFT (SFT))
- High resolution
- High contrast
- Wide color gamut
- LVDS interface
- 8-bit digital signals for data of RGB
- Narrow border
- LED backlight built in LED driver
- Acquisition product for UL60950-1 /CSA C22.2 No.60950-1-03 (File number: E170632)
- Compliant with the European RoHS directive (2011/65/EU)

## 2. GENERAL SPECIFICATIONS

<b>Display area</b>	344.16 (H) × 193.59 (V) mm
<b>Diagonal size of display</b>	40cm (15.6 inches)
<b>Drive system</b>	a-Si TFT active matrix
<b>Display color</b>	16,777,216 colors
<b>Pixel</b>	1,920 (H) × 1,080 (V) pixels
<b>Pixel arrangement</b>	RGB (Red dot, Green dot, Blue dot) vertical stripe
<b>Dot pitch</b>	0.05975 (H) × 0.17925 (V) mm
<b>Pixel pitch</b>	0.17925 (H) × 0.17925 (V) mm
<b>Module size</b>	363.8 (W) × 215.9 (H) × 6.3 (D) mm (typ.)
<b>Weight</b>	610g (typ.)
<b>Contrast ratio</b>	1,000:1 (typ.)
<b>Viewing angle</b>	<p>At the contrast ratio <math>\geq 10:1</math></p> <ul style="list-style-type: none"> <li>• Horizontal: Right side 88° (typ.), Left side 88° (typ.)</li> <li>• Vertical: Up side 88° (typ.), Down side 88° (typ.)</li> </ul>
<b>Designed viewing direction</b>	Viewing angle with optimum grayscale ( $\gamma=2.2$ ): Normal axis (perpendicular)
<b>Polarizer surface</b>	Antiglare
<b>Polarizer pencil-hardness</b>	3H (min.) [by JIS K5600]
<b>Color gamut</b>	<p>At LCD panel center</p> <p>72% (typ.) [against NTSC color space]</p>
<b>Response time</b>	<p><math>T_{on}+T_{off}</math> (10%<math>\leftrightarrow</math>90%)</p> <p>25ms (typ.)</p>
<b>Luminance</b>	<p>At the maximum luminance control</p> <p>400cd/m<sup>2</sup> (typ.)</p>
<b>Signal system</b>	<p>LVDS interface (2 ports)</p> <p>[8-bit digital signals for data of RGB colors, Dot clock (CLK), Data enable (DE)]</p>
<b>Power supply voltage</b>	<p>LCD panel signal processing board: 3.3V</p> <p>LED driver: 12.0V</p>
<b>Backlight</b>	LED backlight built in LED driver
<b>Power consumption</b>	<p>At the maximum luminance control, Checkered flag pattern</p> <p>13.7W (typ.)</p>

**3. BLOCK DIAGRAM**

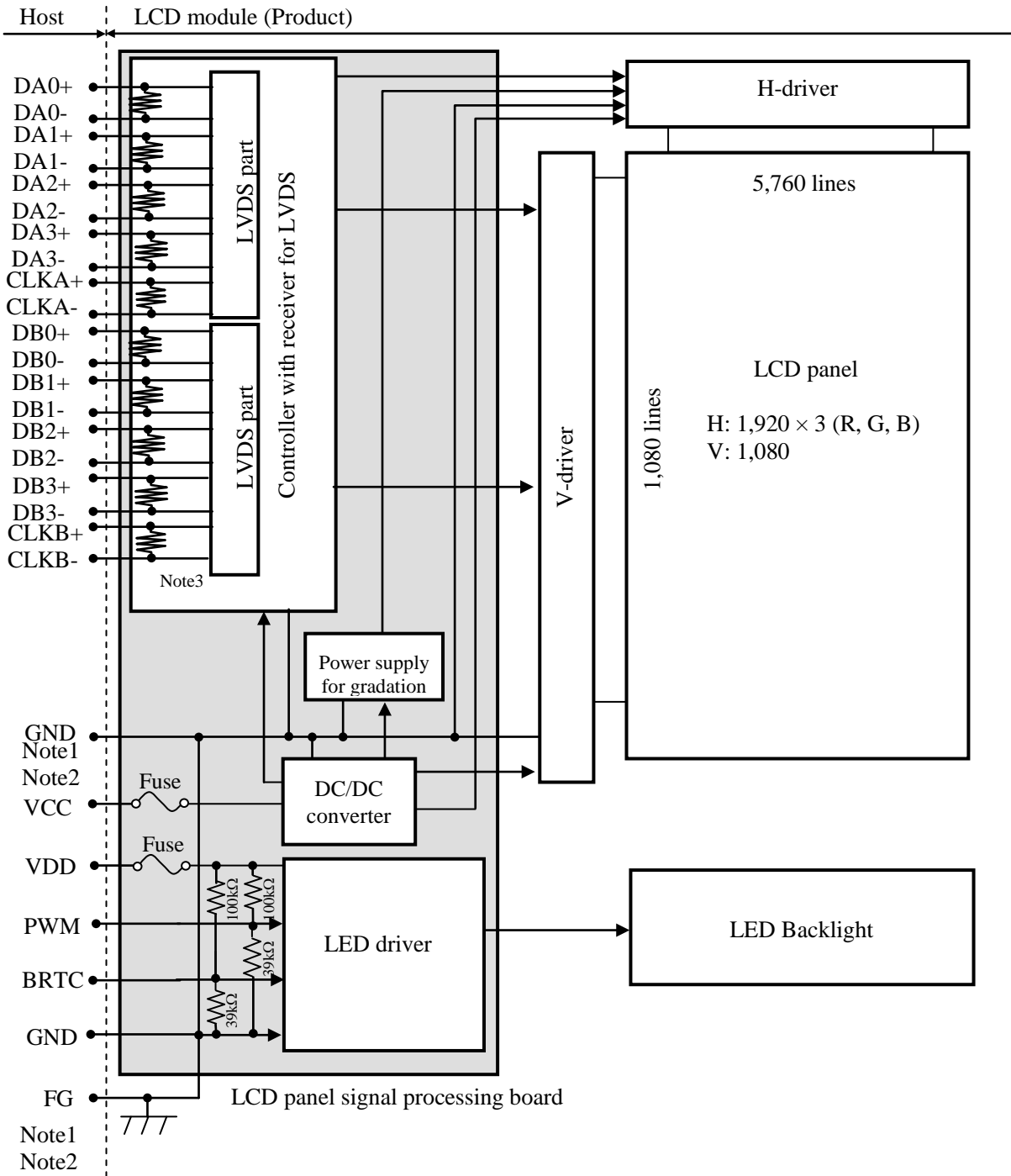

Note1: Relation between GND (Signal ground and LED driver ground) and FG (Frame ground) in the LCD module is as follows.

GND- FG	Connected
---------	-----------

Note2: GND and FG must be connected to customer equipment's ground, and it is recommended that these grounds to be connected together in customer equipment.

Note3: Each pair of the LVDS signal has a 100Ω terminating resistance.

**4. DETAILED SPECIFICATIONS**
**4.1 MECHANICAL SPECIFICATIONS**

Parameter	Specification	Unit
Module size	363.8 ± 0.5 (W) × 215.9 ± 0.5 (H) × 6.3 ± 0.5 (D) Note1	mm
Display area	344.16 (H) × 193.59 (V) Note1	mm
Weight	610 (typ.), 670 (max.)	g

Note1: See "8. OUTLINE DRAWINGS".

**4.2 ABSOLUTE MAXIMUM RATINGS**

Parameter		Symbol	Rating	Unit	Remarks
Power supply voltage	LCD panel signal processing board	VCC	-0.3 to +4.0	V	Ta = 25°C
	LED driver	VDD	-0.3 to +15.0		
Input voltage for signals	LCD panel signal processing board	VD	-0.3 to VCC+0.3	V	
	LED driver			PWM	
		BRTC	-0.3 to +5.5	V	
Storage temperature		Tst	-20 to +70	°C	
Operating temperature	Front surface	TopF	-20 to +70	°C	Note2
	Rear surface	TopR	-20 to +70	°C	Note3
Relative humidity Note4		RH	≤ 95	%	Ta ≤ 40°C
			≤ 85	%	40°C < Ta ≤ 50°C
			≤ 55	%	50°C < Ta ≤ 60°C
			≤ 36	%	60°C < Ta ≤ 70°C
Absolute humidity Note4		AH	≤ 70 Note5	g/m <sup>3</sup>	Ta = 70°C

Note1: DA0+/-, DA1+/-, DA2+/-, DA3+/-, CLKA+/-, DB0+/-, DB1+/-, DB2+/-, DB3+/-, CLKB+/-

Note2: Measured at LCD panel surface (including self-heat)

Note3: Measured at LCD module's rear shield surface (including self-heat)

Note4: No condensation

Note5: Water amount at Ta= 70°C and RH= 36%

☆

4.3 ELECTRICAL CHARACTERISTICS

4.3.1 LCD panel signal processing board

(Ta= 25°C, Note1)

Parameter	Symbol	min.	typ.	max.	Unit	Remarks	
Power supply voltage	VCC	3.0	3.3	3.6	V	-	
Power supply current	ICC	-	530 Note2	1,000 Note3	mA	at VCC= 3.3V	
Permissible ripple voltage	VRPC	-	-	100	mVp-p	for VCC Note4, Note5, Note6	
Differential input threshold voltage	High	VTH	-	-	+100	mV	at VCM= 1.2V Note7, Note8
	Low	VTL	-100	-	-	mV	
Input Differential Voltage	VID	100	400	600	mV	-	
Differential Input Common Mode Voltage	VCM	0.7	1.2	1.6	V	-	
Terminating resistance	RT	-	100	-	Ω	-	

Note1: When designing of the power supply, take the measures for the prevention of surge voltage.

Note2: Checkered flag pattern [by IEC 61747-6]

Note3: Pattern for maximum current

Note4: This product works even if the ripple voltage levels are over the permissible values, but there might be noise on the display image.

Note5: The permissible ripple voltage includes spike noise.

Note6: The load variation influence does not include.

Note7: Common mode voltage for LVDS receiver

Note8: DC characteristics (LVDS receiver part)

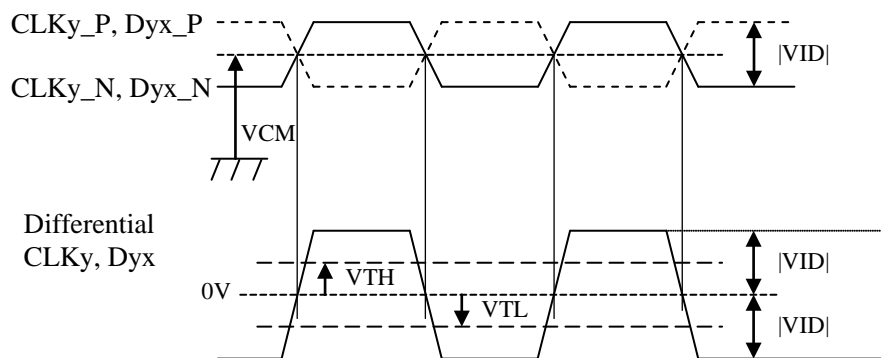

CLKy\_P, CLKy\_N: y = A,B  
 Dyx\_P, Dyx\_N: y = A,B x = 0,1,2,3  
 $|VID| = |**\_P\_**\_N|$   
 $VCM = (**\_P+**\_N)/2$   
 P: +, N: -  
 \*\*: CLKy or Dxy

## 4.3.2 LED driver

(Ta= 25°C, Note1)

Parameter	Symbol	min.	typ.	max.	Unit	Remarks	
Power supply voltage	VDD	10.8	12.0	13.2	V	-	
Power supply current	IDD	-	1,000	1,400 Note2	mA	at VDD= 12.0V, at the maximum luminance control	
Permissible ripple voltage	VRPD	-	-	200	mVp-p	for VDD Note3, Note4, Note5	
Input voltage for PWM signal	High	VDFH1	2.0	-	5.0	V	Note6
	Low	VDFL1	0	-	0.4	V	
Input voltage for BRTC signal	High	VDFH2	2.0	-	5.0	V	
	Low	VDFL2	0	-	0.8	V	
Input current for PWM signal	High	IDFH1	-	-	300	μA	
	Low	IDFL1	-300	-	-	μA	
Input current for BRTC signal	High	IDFH2	-	-	300	μA	
	Low	IDFL2	-300	-	-	μA	
PWM frequency	f <sub>PWM</sub>	200	-	1k	Hz	Note7, Note8	
PWM duty ratio	DR <sub>PWM</sub>	1	-	100	%	Note9, Note10, Note11	
PWM pulse width	tPWH	20	-	-	μs	Note10, Note11	

Note1: When designing of the power supply, take the measures for the prevention of surge voltage.

Note2: This value excludes peak current such as overshoot current.

Note3: This product works even if the ripple voltage levels are over the permissible values, but there might be noise on the display image.

Note4: The permissible ripple voltage includes spike noise.

Note5: The power supply lines (VDD and GND) may have ripple voltage during luminance control of LED. There is the possibility that the ripple voltage produces acoustic noise and signal wave noise in audio circuit and so on.

 Note6: See "**3. BLOCK DIAGRAM**".

 Note7: A recommended f<sub>PWM</sub> value is as follows.

$$f_{PWM} = \frac{2n-1}{4} \times fv$$

(n = integer, fv = frame frequency of LCD module)

Note8: Depending on the frequency used, some noise may appear on the screen, please conduct a thorough evaluation.

 Note9:  $DR_{PWM} = \frac{tPWH}{tPW}$ 

tPWH: PWM pulse width, tPW: PWM dimming cycle (= 1/fPWM)

Note10: While the BRTC signal is high, do not set the tPWH (PWM pulse width) is less than minimum value. It may cause abnormal working of the backlight. In this case, turn the backlight off and then on again by BRTC signal.

Note11: Regardless of the PWM frequency, both PWM duty ratio and PWM pulse width must be always more than the minimum values.

## 4.3.3 Fuse

Parameter	Fuse		Rating	Fusing current	Remarks
	Type	Supplier			
VCC	FCC16152AB	KAMAYA ELECTRIC CO., LTD	1.5A	3.0A 5 seconds	Note1
			36V		
VDD	FCC16202AB	KAMAYA ELECTRIC CO., LTD	2.0A	4.0A 5 seconds	
			36V		

Note1: The power supply's rated current must be more than the fusing current. If it is less than the fusing current, the fuse may not blow in a short time, and then nasty smell, smoke and so on may occur.

4.4 POWER SUPPLY VOLTAGE SEQUENCE

4.4.1 LCD panel signal processing board

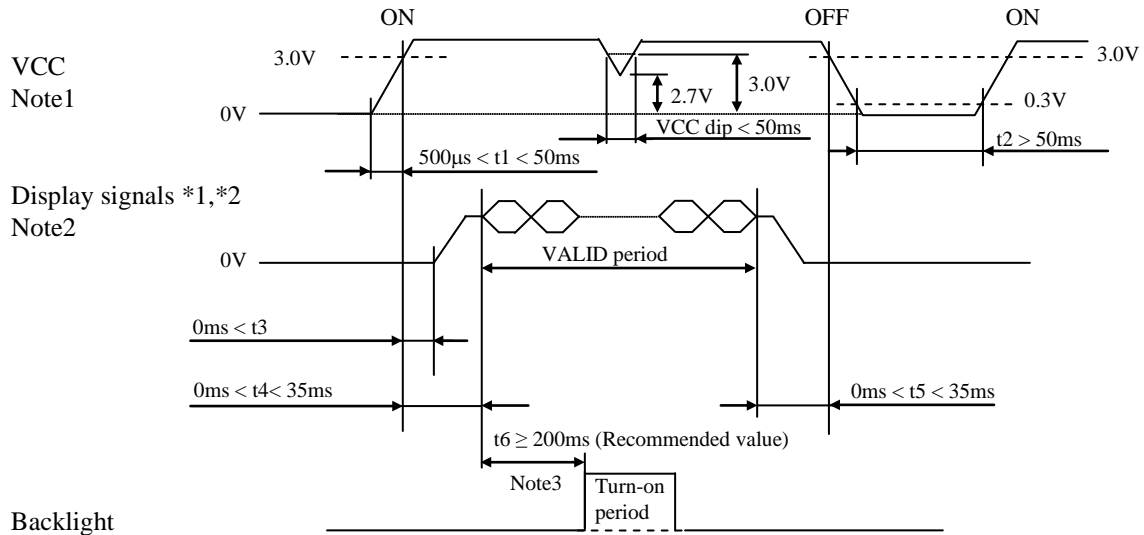

- \*1 DA0+/-, DA1+/-, DA2+/-, DA3+/-, CLKA+/-, DB0+/-, DB1+/-, DB2+/-, DB3+/-, CLKB+/-
- \*2 These signals should be measured at the terminal of 100Ω resistance.

- Note1: If there is a voltage variation (voltage drop) at the rising edge of VCC below 3.0V, there is a possibility that a product does not work due to a protection circuit.
- Note2: Display signals (DA0+/-, DA1+/-, DA2+/-, DA3+/-, CLKA+/-, DB0+/-, DB1+/-, DB2+/-, DB3+/-, CLKB+/-) must be set to Low or High-impedance, except the VALID period (See above sequence diagram), in order to avoid the circuitry damage.  
If some of display signals of this product are cut while this product is working, even if the signal input to it once again, it might not work normally. If a customer stops the display signals, VCC also must be shut down.
- Note3: In order to avoid unstable data display, the backlight is recommended to turn on within the VALID period of display and function signals.  
Recommended value:  $t_6 \geq 200\text{ms}$

4.4.2 LED driver

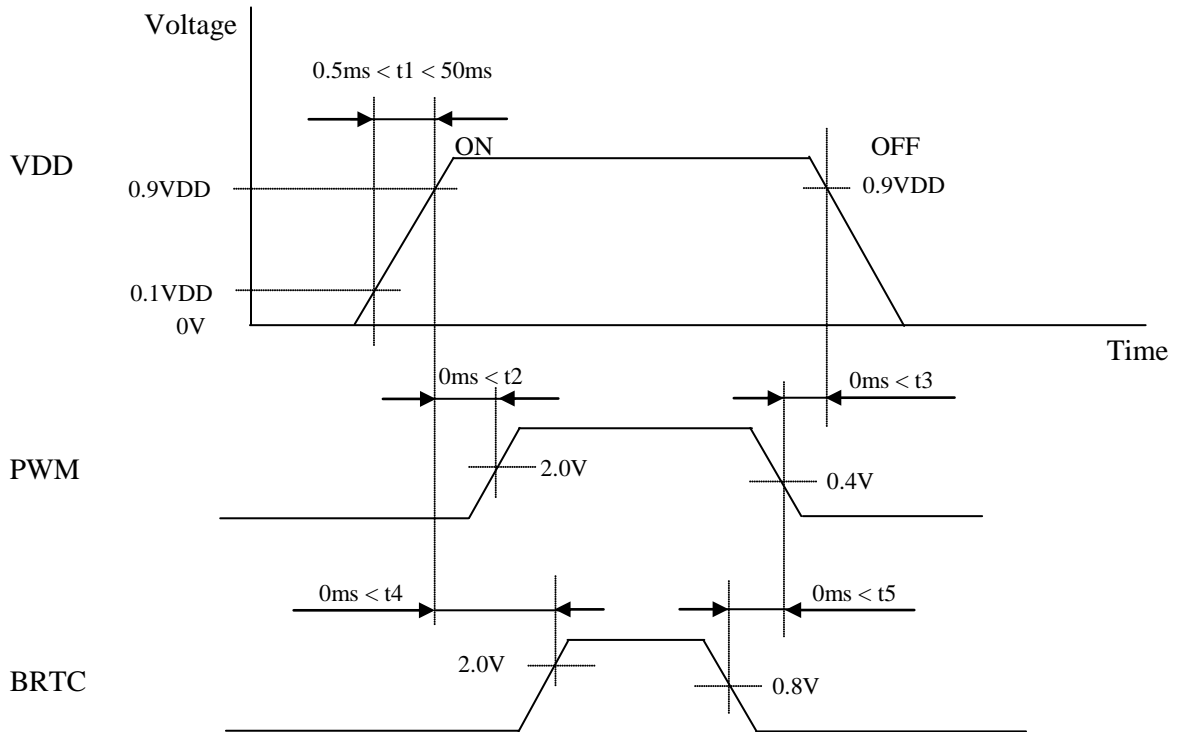

**4.5 CONNECTIONS AND FUNCTIONS FOR INTERFACE PINS**
**4.5.1 LCD panel signal processing board**

CN1 socket (LCD module side): MDF76KBW-30S-1H(55) (HIROSE ELECTRIC Co., Ltd.)

Adaptable plug: MDF76-30P-1C (HIROSE ELECTRIC Co., Ltd.)

Pin No.	Symbol	Signal	Remarks
1	DA0-	Odd pixel data 0	Note1
2	DA0+		
3	DA1-	Odd pixel data 1	Note1
4	DA1+		
5	DA2-	Odd pixel data 2	Note1
6	DA2+		
7	GND	Ground	Note2
8	CLKA-	Odd pixel clock	Note1
9	CLKA+		
10	DA3-	Odd pixel data 3	Note1
11	DA3+		
12	DB0-	Even pixel data 0	Note1
13	DB0+		
14	GND	Ground	Note2
15	DB1-	Even pixel data 1	Note1
16	DB1+		
17	GND	Ground	Note2
18	DB2-	Even pixel data 2	Note1
19	DB2+		
20	CLKB-	Even pixel clock	Note1
21	CLKB+		
22	DB3-	Even pixel data 3	Note1
23	DB3+		
24	GND	Ground	Note2
25	GND	Ground	Note2
26	GND	Ground	Note2
27	GND	Ground	Note2
28	VCC	Power supply	Note2
29			
30			

Note1: Twist pair wires with 100Ω (Characteristic impedance) should be used between LCD panel signal processing board and LVDS transmitter.

Note2: All GND and VCC terminals should be used without any non-connected lines.



4.5.4 Input data mapping

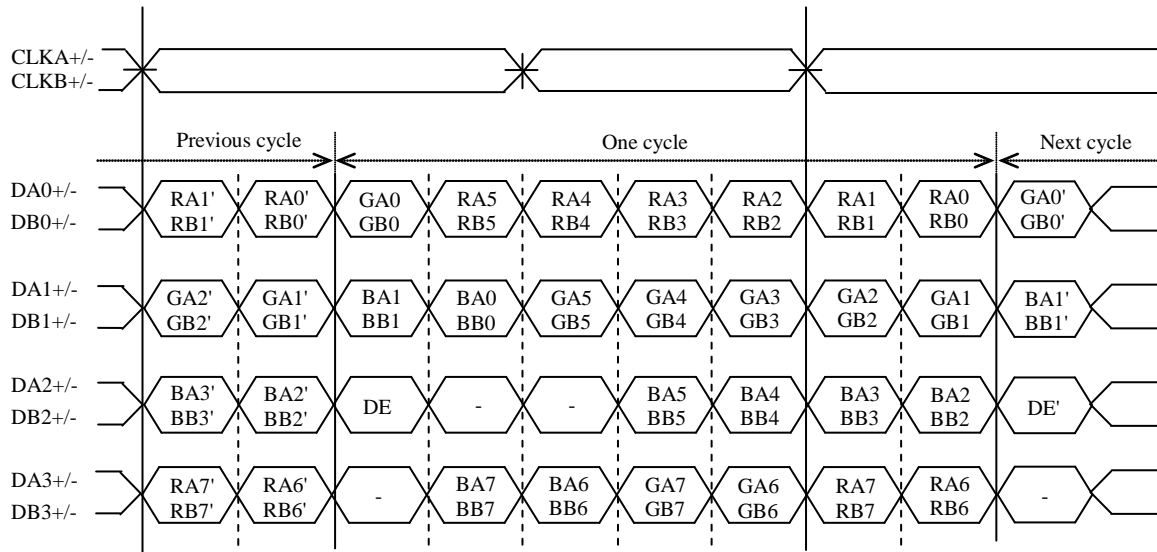

Note1: LSB (Least Significant Bit) – R0, G0, B0 MSB (Most Significant Bit) – R7, G7, B7

Note2: Twist pair wires with 100Ω(Characteristic impedance) should be used between LCD panel signal processing board and LVDS transmitter.

**4.6 DISPLAY COLORS AND INPUT DATA SIGNALS**

This product can display equivalent of 16,777,216 colors with 256 gray scales. Also the relation between display colors and input data signals is as follows.

Display colors		Data signal (0: Low level, 1: High level)																							
		RA7	RA6	RA5	RA4	RA3	RA2	RA1	RA0	GA7	GA6	GA5	GA4	GA3	GA2	GA1	GA0	BA7	BA6	BA5	BA4	BA3	BA2	BA1	BA0
		RB7	RB6	RB5	RB4	RB3	RE2	RB1	RB0	GB7	GB6	GB5	GB4	GB3	GB2	GB1	GB0	BB7	BB6	BB5	BB4	BB3	BB2	BB1	BB0
Basic Colors	Black	0	0	0	0	0	0	0	0	0	0	0	0	0	0	0	0	0	0	0	0	0	0	0	0
	Blue	0	0	0	0	0	0	0	0	0	0	0	0	0	0	0	0	1	1	1	1	1	1	1	1
	Red	1	1	1	1	1	1	1	1	0	0	0	0	0	0	0	0	0	0	0	0	0	0	0	0
	Magenta	1	1	1	1	1	1	1	1	0	0	0	0	0	0	0	0	1	1	1	1	1	1	1	1
	Green	0	0	0	0	0	0	0	0	1	1	1	1	1	1	1	1	0	0	0	0	0	0	0	0
	Cyan	0	0	0	0	0	0	0	0	1	1	1	1	1	1	1	1	1	1	1	1	1	1	1	1
	Yellow	1	1	1	1	1	1	1	1	1	1	1	1	1	1	1	1	0	0	0	0	0	0	0	0
	White	1	1	1	1	1	1	1	1	1	1	1	1	1	1	1	1	1	1	1	1	1	1	1	1
Red gray scale	Black	0	0	0	0	0	0	0	0	0	0	0	0	0	0	0	0	0	0	0	0	0	0	0	0
		0	0	0	0	0	0	0	1	0	0	0	0	0	0	0	0	0	0	0	0	0	0	0	0
	dark	0	0	0	0	0	0	1	0	0	0	0	0	0	0	0	0	0	0	0	0	0	0	0	0
	↑				:	:						:	:							:	:				
	↓				:	:						:	:							:	:				
	bright	1	1	1	1	1	1	0	1	0	0	0	0	0	0	0	0	0	0	0	0	0	0	0	0
Red	1	1	1	1	1	1	1	0	0	0	0	0	0	0	0	0	0	0	0	0	0	0	0	0	
Red	1	1	1	1	1	1	1	1	0	0	0	0	0	0	0	0	0	0	0	0	0	0	0	0	
Green gray scale	Black	0	0	0	0	0	0	0	0	0	0	0	0	0	0	0	0	0	0	0	0	0	0	0	0
		0	0	0	0	0	0	0	0	0	0	0	0	0	0	0	1	0	0	0	0	0	0	0	0
	dark	0	0	0	0	0	0	0	0	0	0	0	0	0	0	1	0	0	0	0	0	0	0	0	0
	↑				:	:						:	:							:	:				
	↓				:	:						:	:							:	:				
	bright	0	0	0	0	0	0	0	0	1	1	1	1	1	1	0	1	0	0	0	0	0	0	0	0
Green	0	0	0	0	0	0	0	0	1	1	1	1	1	1	1	0	0	0	0	0	0	0	0	0	
Green	0	0	0	0	0	0	0	0	1	1	1	1	1	1	1	1	0	0	0	0	0	0	0	0	
Blue gray scale	Black	0	0	0	0	0	0	0	0	0	0	0	0	0	0	0	0	0	0	0	0	0	0	0	0
		0	0	0	0	0	0	0	0	0	0	0	0	0	0	0	0	0	0	0	0	0	0	0	1
	dark	0	0	0	0	0	0	0	0	0	0	0	0	0	0	0	0	0	0	0	0	0	0	1	0
	↑				:	:						:	:							:	:				
	↓				:	:						:	:							:	:				
	bright	0	0	0	0	0	0	0	0	0	0	0	0	0	0	0	0	1	1	1	1	1	1	0	1
Blue	0	0	0	0	0	0	0	0	0	0	0	0	0	0	0	0	1	1	1	1	1	1	1	0	
Blue	0	0	0	0	0	0	0	0	0	0	0	0	0	0	0	0	1	1	1	1	1	1	1	1	

4.7 DISPLAY POSITIONS

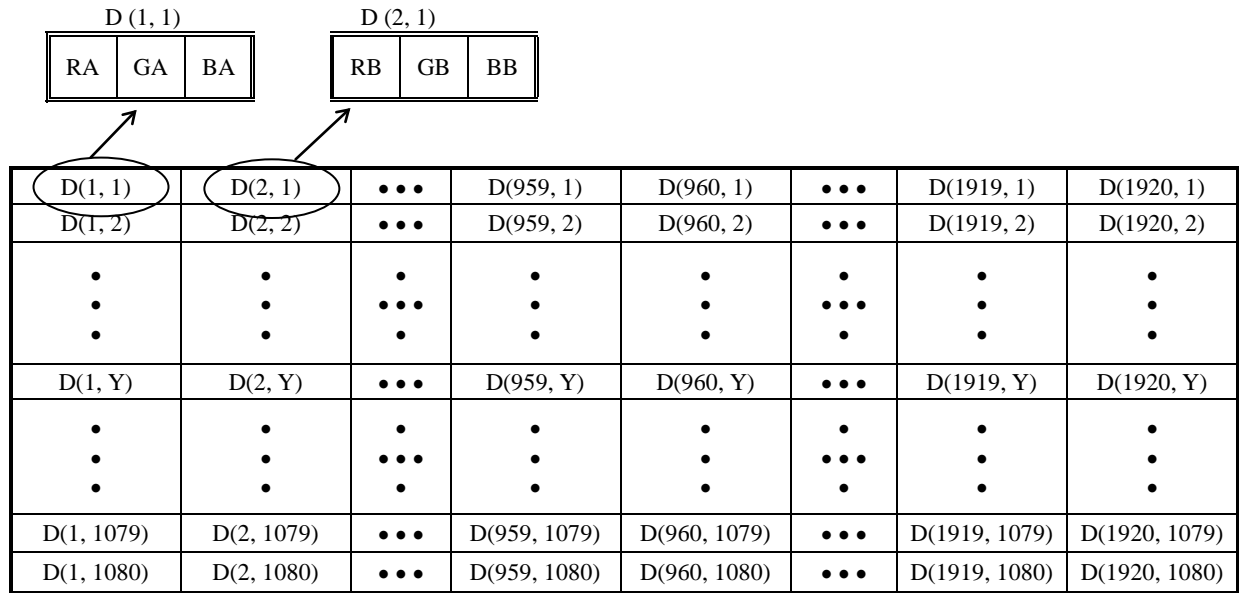

4.8 INPUT SIGNAL TIMINGS

4.8.1 Outline of input signal timings

- Horizontal signal

Note1

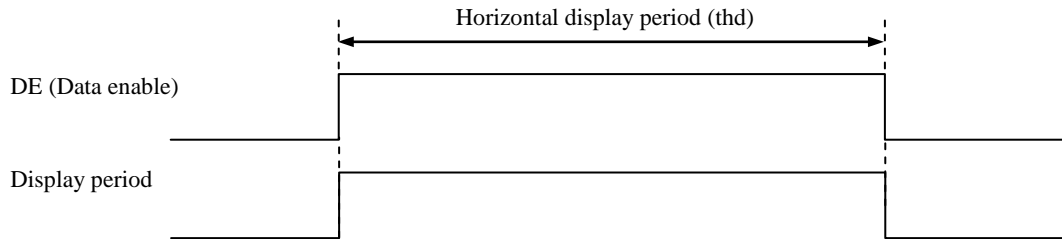

- Vertical signal

Note1

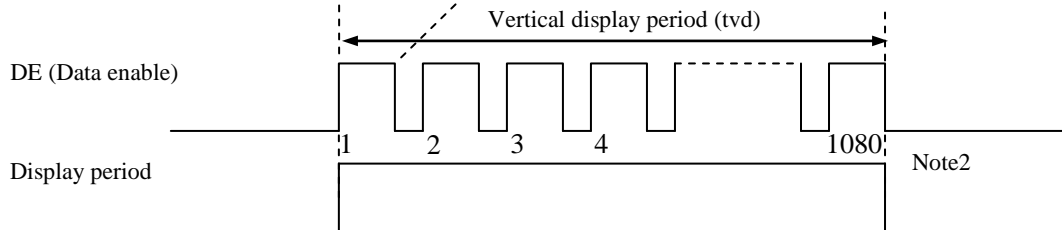

Note1: This diagram indicates virtual signal for set up to timing.

Note2: See "4.8.3 Input signal timing chart" for the pulse number.

## 4.8.2 Timing characteristics

(Note1, Note2, Note3)

Parameter		Symbol	min.	typ.	max.	Unit	Remarks	
CLK	Frequency	1/tc	65.0	74.175	81.5	MHz	13.48ns (typ.)	
	Duty ratio	-	-			-	-	
	Rise time, Fall time	-				ns		
DATA	CLK-DATA	Setup time	-			ns	-	
		Hold time				ns		
	Rise time, Fall time	-				ns		
DE	Horizontal	Cycle	th	13.19	14.83	16.53	μs	67.43kHz (typ.)
		Display period	thd	1,075	1,100	-	CLK	
	Vertical (One frame)	Cycle	tv	15.39	16.68	18.18	ms	59.94Hz (typ.)
		Display period	tvd	1,100	1,125	-	H	
	CLK-DE	Setup time	-	-			ns	-
		Hold time	-				ns	
		Rise time, Fall time	-				ns	
			960			CLK	-	
			1,080			H	-	

Note1: Definition of parameters is as follows.

$$tc = 1CLK, th = 1H$$

Note2: See the data sheet of LVDS transmitter.

Note3: Vertical cycle (tv) should be specified in integral multiple of Horizontal cycle (th).

4.8.3 Input signal timing chart

Horizontal timing

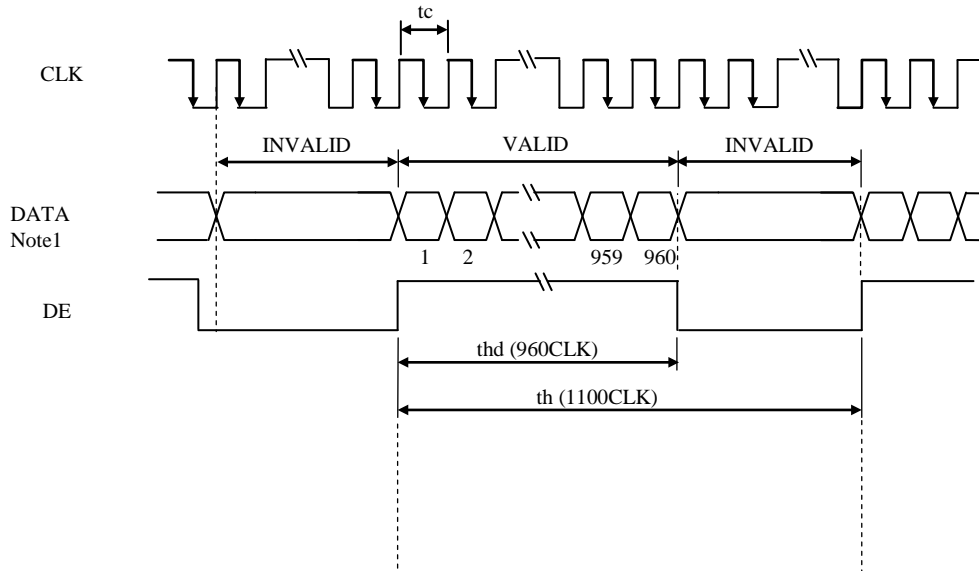

Vertical timing

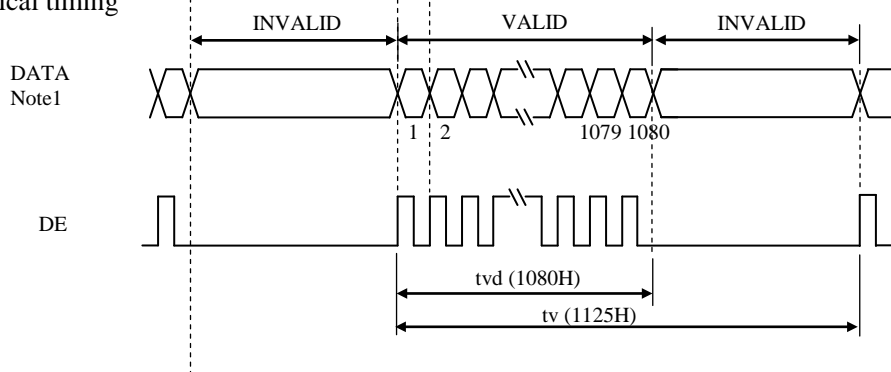

Note1: DATA (A) = RA0-RA7, GA0-GA7, BA0-BA7  
 DATA (B) = RB0-RB7, GB0-GB7, BB0-BB7

4.9 LVDS Rx AC SPEC

Symbol	Parameter	min.	typ.	max.	Units
$t_{RCIP}$	CKy_+ Period	12.27	-	15.38	ns
$t_{RCH}$	CKy_+ High pulse width	-	$\frac{4}{7}t_{RCIP}$	-	ns
$t_{RCL}$	CKy_+ Low pulse width	-	$\frac{3}{7}t_{RCIP}$	-	ns
$t_{RMG}$	Receiver Data Input Margin	-0.4	-	0.4	ns
$t_{RIP1}$	Input Data Position0	$- t_{RMG} $	0.0	$+ t_{RMG} $	ns
$t_{RIP0}$	Input Data Position1	$\frac{t_{RCIP}}{7} -  t_{RMG} $	$\frac{t_{RCIP}}{7}$	$\frac{t_{RCIP}}{7} +  t_{RMG} $	ns
$t_{RIP6}$	Input Data Position2	$2\frac{t_{RCIP}}{7} -  t_{RMG} $	$2\frac{t_{RCIP}}{7}$	$2\frac{t_{RCIP}}{7} +  t_{RMG} $	ns
$t_{RIP5}$	Input Data Position3	$3\frac{t_{RCIP}}{7} -  t_{RMG} $	$3\frac{t_{RCIP}}{7}$	$3\frac{t_{RCIP}}{7} +  t_{RMG} $	ns
$t_{RIP4}$	Input Data Position4	$4\frac{t_{RCIP}}{7} -  t_{RMG} $	$4\frac{t_{RCIP}}{7}$	$4\frac{t_{RCIP}}{7} +  t_{RMG} $	ns
$t_{RIP3}$	Input Data Position5	$5\frac{t_{RCIP}}{7} -  t_{RMG} $	$5\frac{t_{RCIP}}{7}$	$5\frac{t_{RCIP}}{7} +  t_{RMG} $	ns
$t_{RIP2}$	Input Data Position6	$6\frac{t_{RCIP}}{7} -  t_{RMG} $	$6\frac{t_{RCIP}}{7}$	$6\frac{t_{RCIP}}{7} +  t_{RMG} $	ns

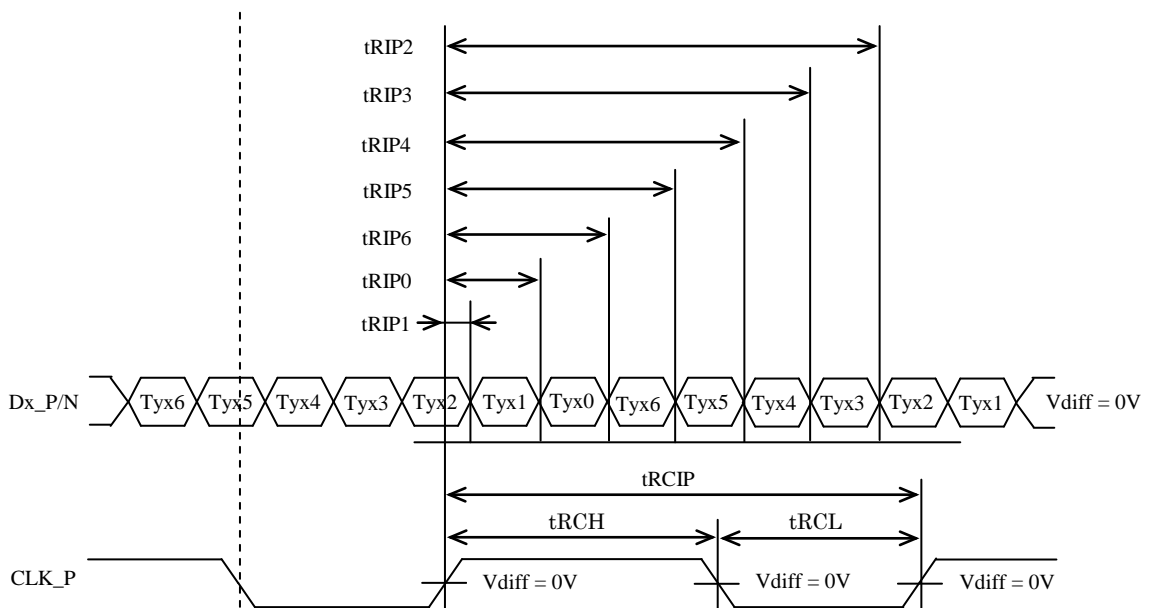

y=A, B  
x = 0,1,2,3



4.10 OPTICS

4.10.1 Optical characteristics

(Note1, Note2)

Parameter	Condition	Symbol	min.	typ.	max.	Unit	Measuring instrument	Remarks	
Luminance	White at center $\theta R=0^\circ, \theta L=0^\circ, \theta U=0^\circ, \theta D=0^\circ$	L	280	400	-	cd/m <sup>2</sup>	BM-5A or equivalent	-	
Contrast ratio	White/Black at center $\theta R=0^\circ, \theta L=0^\circ, \theta U=0^\circ, \theta D=0^\circ$	CR	600	1,000	-	-	BM-5A or equivalent	Note3	
Luminance uniformity	White $\theta R=0^\circ, \theta L=0^\circ, \theta U=0^\circ, \theta D=0^\circ$	LU	-	1.25	1.4	-	BM-5A or equivalent	Note4	
Chromaticity	White	x coordinate	W <sub>x</sub>	0.263	0.313	0.363	-	SR-3 or equivalent	Note5
		y coordinate	W <sub>y</sub>	0.279	0.329	0.379	-		
	Red	x coordinate	R <sub>x</sub>	-	0.630	-	-		
		y coordinate	R <sub>y</sub>	-	0.335	-	-		
	Green	x coordinate	G <sub>x</sub>	-	0.290	-	-		
		y coordinate	G <sub>y</sub>	-	0.620	-	-		
Blue	x coordinate	B <sub>x</sub>	-	0.155	-	-			
	y coordinate	B <sub>y</sub>	-	0.065	-	-			
Color gamut	$\theta R=0^\circ, \theta L=0^\circ, \theta U=0^\circ, \theta D=0^\circ$ at center, against NTSC color space	C	65	72	-	%			
Response time	Black to White	Ton	-	12	20	ms	BM-5A or equivalent	Note6	
	White to Black	Toff	-	13	20	ms		Note7	
Viewing angle	Right	$\theta U=0^\circ, \theta D=0^\circ, CR \geq 10$	$\theta R$	70	88	-	EZ Contrast	Note8	
	Left	$\theta U=0^\circ, \theta D=0^\circ, CR \geq 10$	$\theta L$	70	88	-			
	Up	$\theta R=0^\circ, \theta L=0^\circ, CR \geq 10$	$\theta U$	70	88	-			
	Down	$\theta R=0^\circ, \theta L=0^\circ, CR \geq 10$	$\theta D$	70	88	-			

Note1: These are initial characteristics.

Note2: Measurement conditions are as follows.

Ta= 25°C, VCC= 3.3V, VDD=12.0V, PWM duty ratio: 100%,

Display mode: FHD, Horizontal cycle= 1/67.43kHz, Vertical cycle= 1/59.94Hz,

Optical characteristics are measured at luminance saturation 20minutes after the product works in the dark room. Also measurement methods are as follows.

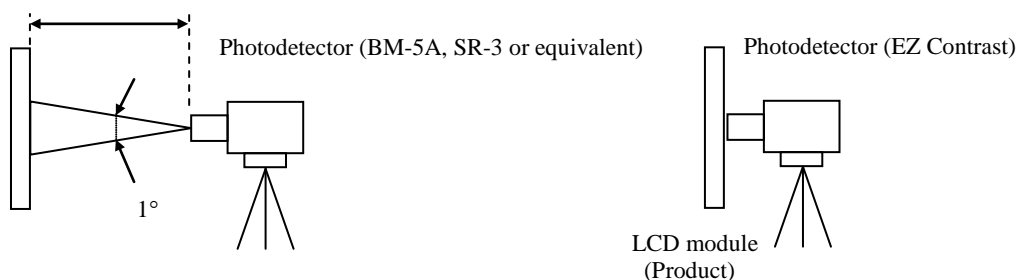

Note3: See "4.10.2 Definition of contrast ratio".

Note4: See "4.10.3 Definition of luminance uniformity".

Note5: These coordinates are found on CIE 1931 chromaticity diagram.

Note6: Product surface temperature: TopF= 29°C

Note7: See "4.10.4 Definition of response times".

Note8: See "4.10.5 Definition of viewing angles".

4.10.2 Definition of contrast ratio

The contrast ratio is calculated by using the following formula.

$$\text{Contrast ratio (CR)} = \frac{\text{Luminance of white screen}}{\text{Luminance of black screen}}$$

4.10.3 Definition of luminance uniformity

The luminance uniformity is calculated by using following formula.

$$\text{Luminance uniformity (LU)} = \frac{\text{Maximum luminance from ① to ⑤}}{\text{Minimum luminance from ① to ⑤}}$$

The luminance is measured at near the 5 points shown below.

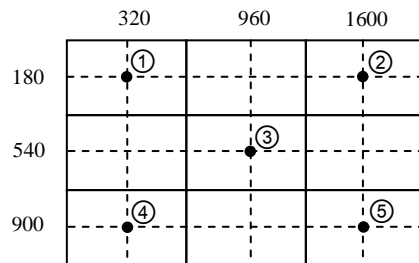

4.10.4 Definition of response times

Response time is measured at the time when the luminance changes from "black" to "white", or "white" to "black" on the same screen point, by photo-detector. Ton is the time when the luminance changes from 10% up to 90%. Also Toff is the time when the luminance changes from 90% down to 10% (See the following diagram.).

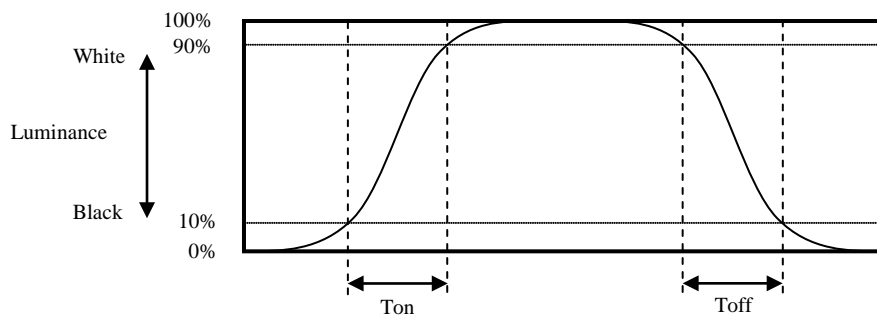

4.10.5 Definition of viewing angles

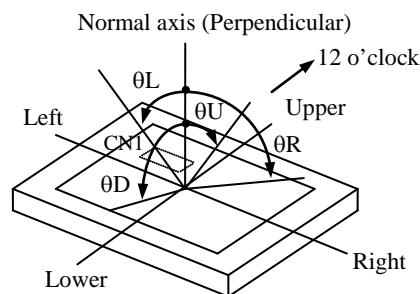

## 5. ESTIMATED LUMINANCE LIFETIME

The luminance lifetime is the time from initial luminance to half-luminance.

**This lifetime is the estimated value, and is not guarantee value.**

Condition		Estimated luminance lifetime (Life time expectancy) Note1, Note2, Note3	Unit
LED elementary substance	25°C (Ambient temperature of the product) Continuous operation, PWM duty ratio:100%	50,000	h
	70°C (Temperature of LCD panel surface and rear shield surface) Continuous operation, PWM duty ratio:100%	30,000	

Note1: Life time expectancy is mean time to half-luminance.

Note2: Estimated luminance lifetime is not the value for LCD module but the value for LED elementary substance.

Note3: By ambient temperature, the lifetime changes particularly. Especially, in case the product works under high temperature environment, the lifetime becomes short.

## 6. RELIABILITY TESTS

Test item	Condition	Judgment	Note1	
High temperature and humidity (Operation)	① $+60 \pm 2^{\circ}\text{C}$ , RH= 60%, 240hours ② Display data is white.	No display malfunctions		
High temperature (Operation)	① $+70 \pm 3^{\circ}\text{C}$ , 240hours ② Display data is white.			
Low temperature (Operation)	① $-20 \pm 3^{\circ}\text{C}$ , 300hours ② Display data is white.			
Thermal shock (Non operation)	① $-20 \pm 3^{\circ}\text{C}$ ...30minutes $+60 \pm 3^{\circ}\text{C}$ ...30minutes ② 100cycles, 1hour/cycle ③ Temperature transition time is within 5 minutes.			
ESD (Operation)	① 150pF, 150Ω, $\pm 10\text{kV}$ ② 9 places on a panel surface ③ 10 times each point at 1 sec interval			Note2
Dust (Operation)	① Sample dust: No. 15 (by JIS-Z8901) ② 15 seconds stir ③ 8 times repeat at 1 hour interval			
Vibration (Non operation)	① 5 to 100Hz, $11.76\text{m/s}^2$ ② 1 minute/cycle ③ X, Y, Z directions ④ 50 times each direction			No display malfunctions No physical damages
Mechanical shock (Non operation)	① $294\text{m/s}^2$ , 11ms ② $\pm\text{X}$ , $\pm\text{Y}$ , $\pm\text{Z}$ directions ③ 3 times each direction			

Note1: Display and appearance are checked under environmental conditions equivalent to the inspection conditions of defect criteria.

Note2: See the following figure for discharge points.

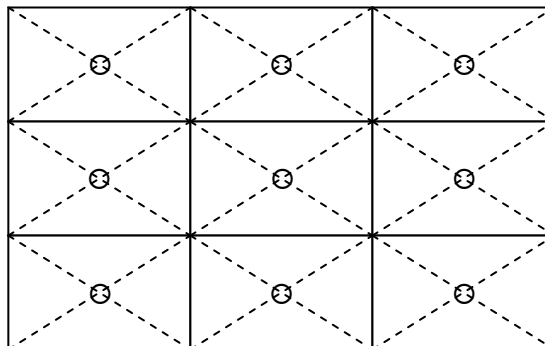

**7. PRECAUTIONS**

7.1 MEANING OF CAUTION SIGNS

The following caution signs have very important meaning. **Be sure to read "7.2 CAUTIONS" and "7.3 ATTENTIONS"!**

	This sign has the meaning that a customer will be injured or the product will sustain damage if the customer practices wrong operations.
-----------------------------------------------------------------------------------	------------------------------------------------------------------------------------------------------------------------------------------

	This sign has the meaning that a customer will be injured if the customer practices wrong operations.
-----------------------------------------------------------------------------------	-------------------------------------------------------------------------------------------------------

7.2 CAUTIONS

	<p><b>* Do not shock and press the LCD panel and the backlight! There is a danger of breaking, because they are made of glass. (Shock: Equal to or no greater than 294m/s<sup>2</sup> and equal to or no greater than 11ms, Pressure: Equal to or no greater than 19.6 N (φ16mm jig))</b></p>
-----------------------------------------------------------------------------------	-----------------------------------------------------------------------------------------------------------------------------------------------------------------------------------------------------------------------------------------------------------------------------------------------

7.3 ATTENTIONS 

7.3.1 Handling of the product

- ① Take hold of both ends without touching the circuit board when the product (LCD module) is picked up from inner packing box to avoid broken down or misadjustment, because of stress to mounting parts on the circuit board.
- ② Do not hook nor pull cables such as lamp cable, and so on, in order to avoid any damage.
- ③ When the product is put on the table temporarily, display surface must be placed downward.
- ④ When handling the product, take the measures of electrostatic discharge with such as earth band, ionic shower and so on, because the product may be damaged by electrostatic.
- ⑤ The torque for product mounting screws must never exceed 0.230N·m. Higher torque might result in distortion of the bezel. And the length of product mounting screws must be ≤ 2.5mm.
- ⑥ The product must be installed using mounting holes without undue stress such as bends or twist (See outline drawings). And do not add undue stress to any portion (such as bezel flat area). Bends or twist described above and undue stress to any portion may cause display mura.  
Recommended installing method: Ideal plane "A" is defined by one mounting hole (datum point) and other mounting holes. The ideal plane "A" should be the same plane within ±0.3 mm.

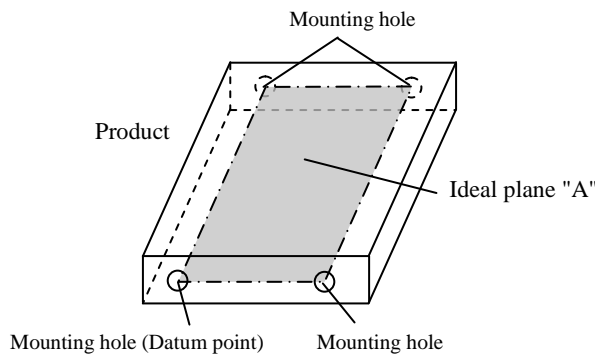

- ⑦ Do not press or rub on the sensitive product surface. When cleaning the panel surface, wipe it with a soft dry cloth.
- ⑧ Do not push or pull the interface connectors while the product is working.
- ⑨ When handling the product, use of an original protection sheet on the product surface (polarizer) is recommended for protection of product surface. Adhesive type protection sheet may change color or characteristics of the polarizer.
- ⑩ Usually liquid crystals don't leak through the breakage of glasses because of the surface tension of thin layer and the construction of LCD panel. But, if you contact with liquid crystal by any chance, please wash it away with soap and water.

☆

### 7.3.2 Environment

- ① Do not operate or store in high temperature, high humidity, dewdrop atmosphere or corrosive gases. Keep the product in packing box with antistatic pouch in room temperature to avoid dusts and sunlight, when storing the product.
- ② In order to prevent dew condensation occurred by temperature difference, the product packing box must be opened after enough time being left under the environment of an unpacking room. Evaluate the storage time sufficiently because dew condensation is affected by the environmental temperature and humidity. (Recommended leaving time: 6 hours or more with the original packing state after a customer receives the package)
- ③ Do not operate in high magnetic field. If not, circuit boards may be broken.
- ④ This product is not designed as radiation hardened.

### 7.3.3 Characteristics

**The following items are neither defects nor failures.**

- ① Characteristics of the LCD (such as response time, luminance, color uniformity and so on) may be changed depending on ambient temperature. If the product is stored under condition of low temperature for a long time, it may cause display mura. In this case, the product should be operated after enough time being left under condition of operating temperature.
- ② Display mura, flickering, vertical streams or tiny spots may be observed depending on display patterns.
- ③ Do not display the fixed pattern for a long time because it may cause image sticking. Use a screen saver, if the fixed pattern is displayed on the screen.
- ④ The display color may be changed depending on viewing angle because of the use of condenser sheet in the backlight.
- ⑤ Optical characteristics may be changed depending on input signal timings.
- ⑥ The interference noise between input signal frequency for this product's signal processing board and luminance control frequency of backlight driving circuit may appear on a display. Set up luminance control frequency of backlight driving circuit so that the interference noise does not appear.

☆

## 7.3.4 Others

- ① All GND, VCC and VDD terminals should be used without any non-connected lines.
- ② Do not disassemble a product or adjust variable resistors.
- ③ Pack the product with the original shipping package, in order to avoid any damages during transportation, when returning the product to TMJ.
- ④ The information of China RoHS (II) six hazardous substances or elements in this product is as follows.

China RoHS (II) six hazardous substances or elements					
Lead (Pb)	Mercury (Hg)	Cadmium (Cd)	Hexavalent Chromium (Cr VI)	Polybrominated Biphenyls (PBB)	Polybrominated Biphenyl Ethers (PBDE)
×	○	○	○	○	○

Note1: ○: This indicates that the poisonous or harmful material in all the homogeneous materials for this part is equal or below the limitation level of GB/T26572-2011 standard regulation.

×: This indicates that the poisonous or harmful material in all the homogeneous materials for this part is above the limitation level of GB/T26572-2011 standard regulation.

8. OUTLINE DRAWINGS

8.1 FRONT VIEW

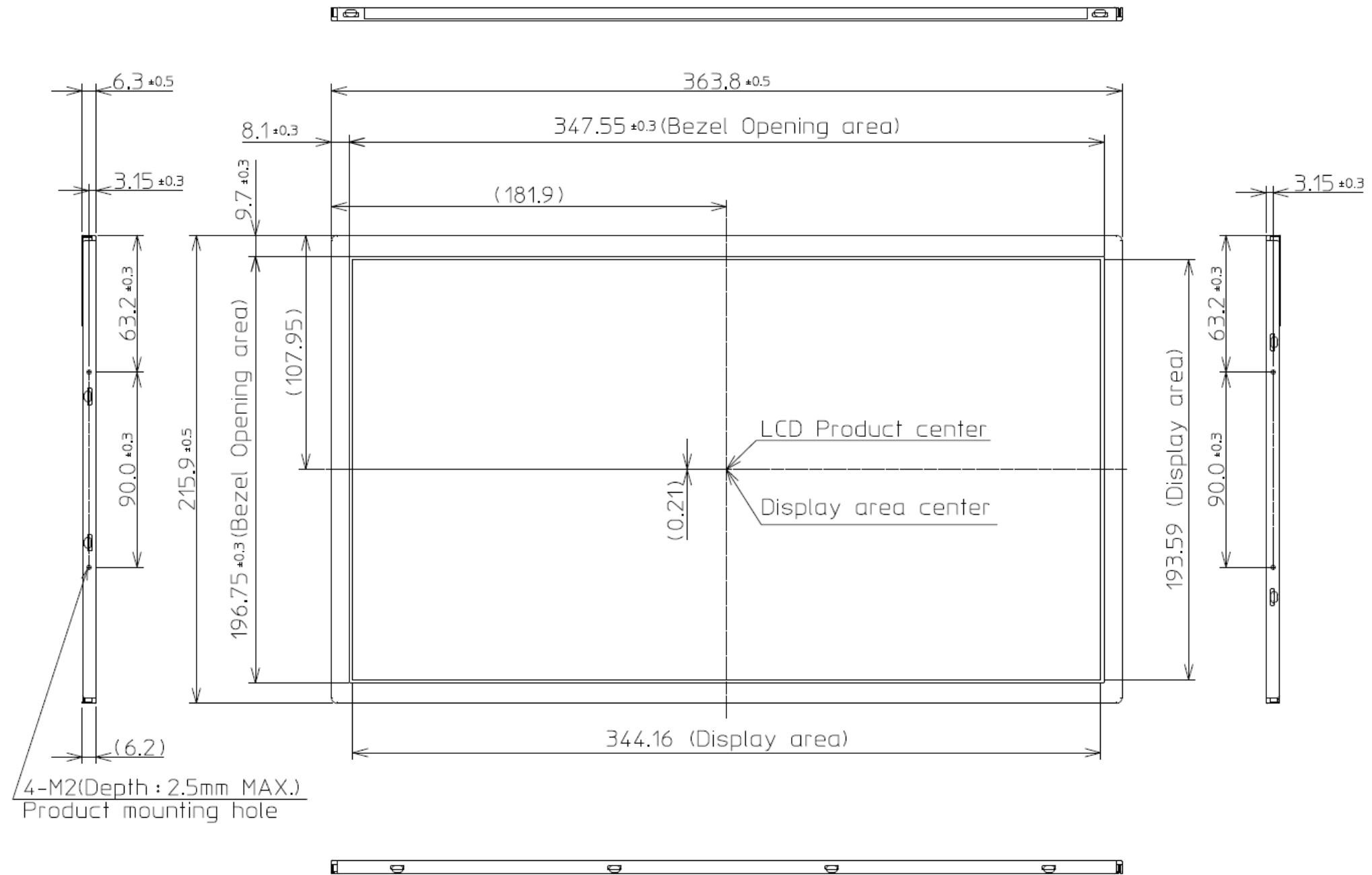

Note1: The values in parentheses are for reference.

Note2: The torque for product mounting screws must never exceed 0.230N·m. And the length of product mounting screws must be ≤ 2.5mm.

Unit: mm



## REVISION HISTORY

*The inside of latest specifications is revised to the clerical error and the major improvement of previous edition. Only a changed part such as functions, characteristic value and so on that may affect a design of customers, are described especially below.*

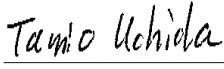
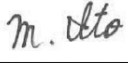
Edition	Document number	Prepared date	Revision contents and signature
1st edition	DOD-PP-2571	Mar.28, 2017	<p><b>Revision contents</b></p> <p>PRELIMINARY DATA SHEET DOD-PP-2509(5) → DATA SHEET DOD-PP-2571(1)</p> <p>P4 Outline - Features</p> <ul style="list-style-type: none"> <li>• Acquisition product for UL60950-1/CSA C22.2 No.60950-1-03 (File number: E170632) (addition)</li> <li>• Compliance with the European RoHS directive (2011/65/EU) (addition)</li> </ul> <p>P26 Attentions - Others</p> <ul style="list-style-type: none"> <li>• ④ (addition)</li> </ul> <p>P28 Outline Drawings – REAR VIEW</p> <ul style="list-style-type: none"> <li>• Addition of slit on barrier (correction)</li> </ul> <p><b>Writer</b></p> <p><i>Approved by</i> <u>R. KAWASHIMA</u>      <i>Checked by</i> <u>T. OGAWA</u>      <i>Prepared by</i> <u>M. ITO</u></p>
2nd edition	DOD-PP-3095	Apr. 17, 2019	<p><b>Revision contents</b></p> <p>CORRECTION OF DESCRIPTIVE CONTENTS</p> <ul style="list-style-type: none"> <li>• Change of company name</li> </ul> <p>P4 Outline - Features</p> <ul style="list-style-type: none"> <li>• High resolution (addition)</li> <li>• Wide temperature range (elimination)</li> <li>• Narrow frame → Narrow border (Revised)</li> </ul> <p>P7 Detailed specifications – Absolute maximum ratings</p> <ul style="list-style-type: none"> <li>• Function signal for LED driver → LED driver (Revised)</li> </ul> <p>P8 Electrical characteristics - LCD panel signal processing board</p> <ul style="list-style-type: none"> <li>• Note1 (addition)</li> </ul> <p>P9 Electrical characteristics - LED driver</p> <ul style="list-style-type: none"> <li>• Note1 (Position correction)</li> <li>• Note3 (elimination)</li> <li>• Power supply current – Remarks: at the maximum luminance control (addition)</li> <li>• Note9 (addition)</li> </ul> <p>P20 LVDS Rx AC SPEC (Revised)</p> <p>P25 Attentions – Handling of the product</p> <ul style="list-style-type: none"> <li>• ② (addition)</li> </ul> <p>P26 Attentions – Handling of the product</p> <ul style="list-style-type: none"> <li>• ⑧ → ⑧, ⑨ (division)</li> </ul> <p>P26 Attentions – Characteristics</p> <ul style="list-style-type: none"> <li>• ⑥ (addition)</li> </ul> <p><b>Signature of writer</b></p> <p><i>Approved by</i>  <u>R. KAWASHIMA</u>      <i>Checked by</i>  <u>T. UCHIDA</u>      <i>Prepared by</i>  <u>M. ITO</u></p>