

BOE TFT-LCD

MODEL: HPX172V1

Issue Date : 2020/01/06

- (*) Preliminary Specifications
() Final Specifications

BOE	Drafter By	
	Approved By	
Customer	Signature	

MODEL	HPX172V1	Doc. No		Page	1 / 20
--------------	-----------------	----------------	--	-------------	---------------

CONTENTS

REVISION HISTORY.....	3
1. GENERAL DESCRIPTION.....	4
1.1 OVERVIEW.....	4
1.2 GENERAL SPECIFICATIONS.....	4
2. MECHANICAL SPECIFICATIONS.....	4
3. ABSOLUTE MAXIMUM RATINGS.....	5
3.1 ABSOLUTE RATINGS OF ENVIRONMENT.....	5
4. ELECTRICAL SPECIFICATIONS.....	5
4.1 FUNCTION BLOCK DIAGRAM.....	6
4.2 INTERFACE CONNECTIONS.....	6
4.3 ELECTRICAL CHARACTERISTICS.....	7
4.3.1 LCD ELECTRONICS SPECIFICATION.....	7
4.3.2 BACKLIGHT UNIT.....	9
4.4 LVDS INPUT SIGNAL SPECIFICATIONS.....	10
4.4.1 COLOR DATA INPUT ASSIGNMENT.....	10
4.5 DISPLAY TIMMING SPECIFICATIONS.....	11
4.6 POWER ON/OFF SEQUENCE.....	13
5. OPTICAL CHARACTERISTICS.....	14
5.1 TEST CONDITIONS.....	14
5.2 OPTICAL SPECIFICATIONS.....	14
6. RELIABILITY TEST ITEM.....	17
7. PACKGING.....	18
8. MODULE LABEL.....	18
9. PRECAUTIONS.....	18
9.1 ASSEMBLY AND HANDLING PRECAUTIONS.....	18
9.2 STORAGE PRECAUTIONS.....	18
9.3 OPERATION PRECAUTIONS.....	19
9.4 SAFETY PRECAUTIONS.....	19
9.5 SAFETY STANDARDS.....	19
9.6 OTHER.....	19
APPENDIX. OUTLINE DRAWING.....	19

MODEL	HPX172V1	Doc. No		Page	2 / 20
-------	----------	---------	--	------	--------

1. GENERAL DESCRIPTION

1.1 OVERVIEW

This specification applies to the 17.2 inch Color TFT-LCD Module HPX172V1. This LCD module has a TFT active matrix type liquid crystal panel 1366x510 pixels, and diagonal size of 17.2 inch. This module supports 1366x768 mode. Each pixel is divided into Red, Green and Blue sub-pixels or dots which are arranged in vertical stripes. Gray scale or the brightness of the sub-pixel color is determined with a 8-bit gray scale signal for each dot. The HPX172V1 has been designed to apply the 8-bit 1 channel LVDS interface method. It is intended to support displays where high brightness, wide viewing angle, high color saturation, and high color depth are very important.

1.2 GENERAL SPECIFICATIONS

Item	Specification	Unit	Note
Screen Size	17.2	Inch	-
Driver Element	a-Si TFT active matrix	-	-
Pixel Number	1366 x R.G.B. x 500	Pixel	
Pixel pitch	0.3(H) x 0.3(W)	mm	
Pixel Arrangement	RGB vertical stripe	-	
Display Colors	16.7 millions	Color	
Transmissive Mode	Normally Black	-	
Surface Treatment	Hard coating (3H), AG (Haze 1%)	-	
Luminance, White	500 (typical)	Cd/m2	
Color Gamut	72% of NTSC(Typ.)	-	
Power Consumption	Total 14.84W (Max.) @ cell 6.86W (Max.), BL 7.98W (Max.)		(1)

Note(1) The specified power consumption: Total=cell(reference 4.3.1)+BL(reference 4.3.3)

2. MECHANICAL SPECIFICATIONS

Item		Min	Typ.	Max	Unit	Note
Module Size	Horizontal(H)	Typ-1	430	Typ+1	mm	(1)
	Vertical (V)	Typ-1	174.2	Typ+1	mm	
	Thickness (T)	Typ-1	19.8	Typ+1	mm	
Bezel Area	Horizontal	Typ-0.3	413.8		mm	
	Vertical	Typ-0.3	154	Typ+0.3	mm	
Active Area	Horizontal	-	409.8	-	mm	
	Vertical	-	150	-	mm	
Weight		-	-	-	g	

Note (1) Please refer to the attached drawings for more information of front and back outline dimensions.

MODEL	HPX172V1	Doc. No		Page	4 / 20
--------------	-----------------	----------------	--	-------------	---------------

3. ABSOLUTE MAXIMUM RATINGS

3.1 ABSOLUTE RATINGS OF ENVIRONMENT

Item	Symbol	Value		Unit	Note
		Min.	Max.		
Storage Temperature	TST	-20	+60	°C	(1)
Operating Ambient Temperature	TOP	0	+50	°C	(1),(2)

Note (1)

- (a) 90 %RH Max. ($T_a \leq 40 \text{ }^\circ\text{C}$).
- (b) Wet-bulb temperature should be 39 °C Max. ($T_a > 40 \text{ }^\circ\text{C}$).
- (c) No condensation.

Note (2) The temperature of panel surface should be 0 °C min. and 60 °C max.

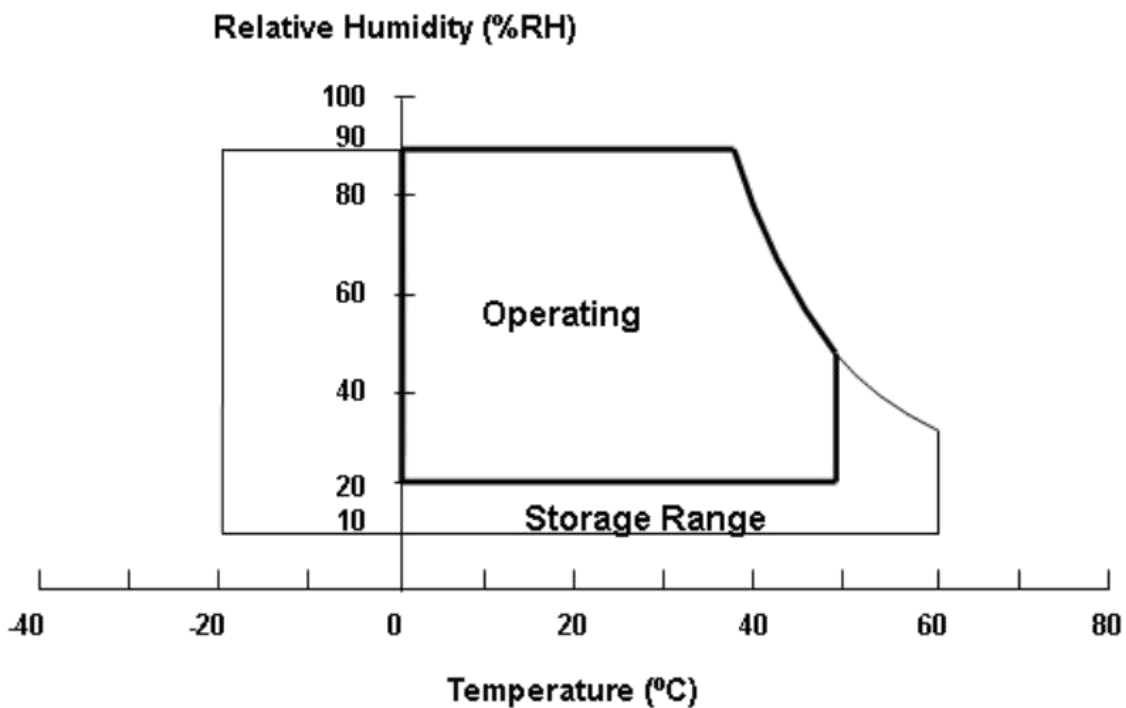

4. ELECTRICAL SPECIFICATIONS

MODEL	HPX172V1	Doc. No		Page	5 / 20
-------	----------	---------	--	------	--------

4.1 FUNCTION BLOCK DIAGRAM

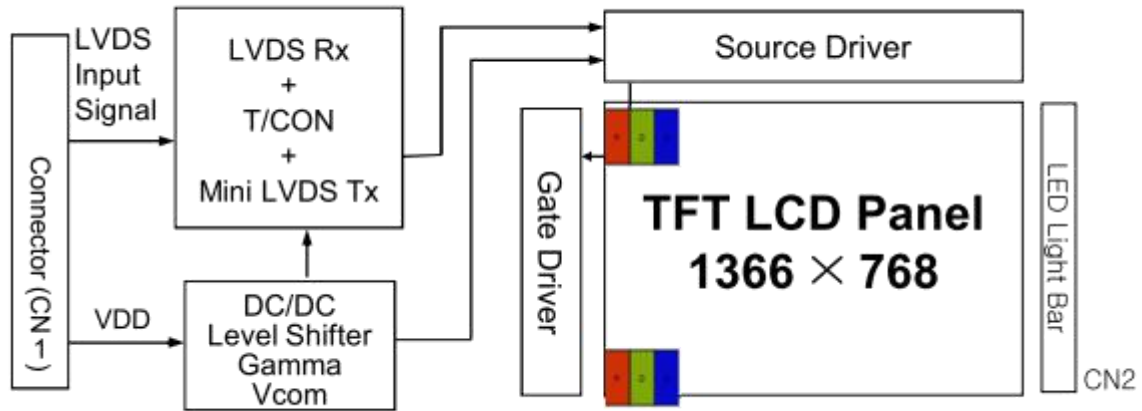

4.2 INTERFACE CONNECTIONS

Module Side Connector : UJU IS100-300-C23 or Equivalent

User Side Connector : JAE FI-X30H or Equivalent

PIN ASSIGNMENT

Pin	Symbol	Description	Pin	Symbol	Description
1	NC	No Connection	16	GND	Ground
2	NC	No Connection	17	RX3N	LVDS Signal- CH3
3	NC	No Connection	18	RX3P	LVDS Signal+ CH3
4	GND	Ground	19	GND	Ground
5	RX0N	LVDS Signal- CH0	20	NC	No Connection
6	RX0P	LVDS Signal+ CH0	21	NC	No Connection
7	GND	Ground	22	NC	No Connection
8	RX1N	LVDS Signal- CH1	23	GND	Ground
9	RX1P	LVDS Signal+ CH1	24	GND	Ground
10	GND	Ground	25	GND	Ground
11	RX2N	LVDS Signal- CH2	26	VDD	Power supply 5V
12	RX2P	LVDS Signal+ CH2	27	VDD	Power supply 5V
13	GND	Ground	28	VDD	Power supply 5V
14	RXCLKN	LVDS Signal- CLOCK	29	VDD	Power supply 5V
15	RXCLKP	LVDS Signal+CLOCK	30	VDD	Power supply 5V

Notes :

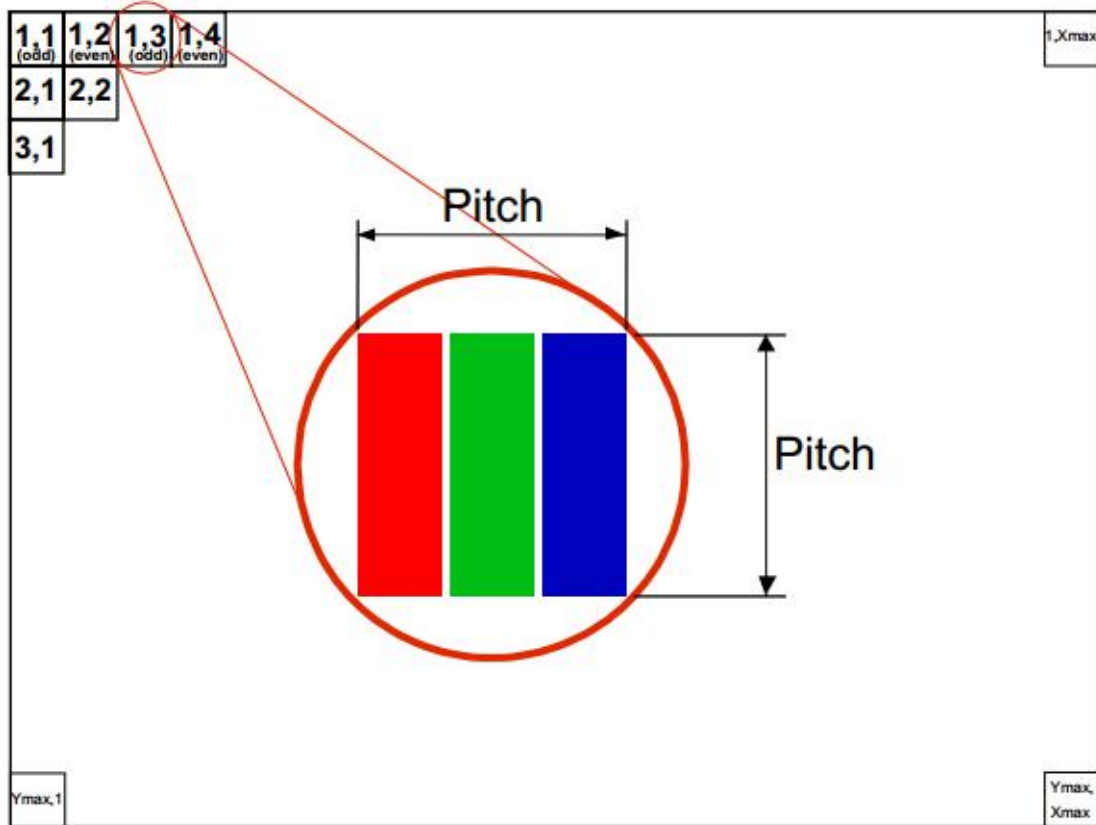

Note(2)

- All GND pins should be connected together to the LCD module's metal frame.
- All 5V(power input) pins should be connected together.
- All Input levels of LVDS signals are based on the EIA 644 Standard.

4.3 ELECTRICAL CHARACTERSISTICS

4.3.1 LCD ELETRONICS SPECIFICATION

Item	Symbol	Value			Unit	Note
		Min.	Typ.	Max.		
Power Supply Voltage	Vcc	4.5	5	5.5	V	-
Ripple Voltage	VRP	-	900	1100	mV	-
Rush Current	IRUSH	-	2	3	A	(2)
Power Supply Current	White	-	440	520	mA	(3)a
	Black	-	272	318	mA	(3)
	Vertical Stripe	-	425	504	mA	(3)c
Power Consumption	PLCD	-	5.28	6.864	Watt	(4)(6)
LVDS differential input voltage	Vid	200	-	600	mV	
LVDS common input voltage	Vic	1.0	1.2	1.5	V	
Logic High Input Voltage	VIH	2.7		3.3	V	
Logic Low Input Voltage	VIL	0		0.7	V	

Note (1) The ambient temperature is Ta = 25 ± 2 °C.

Note (2) Measurement Conditions:

V_{CC} rising time is 470μs

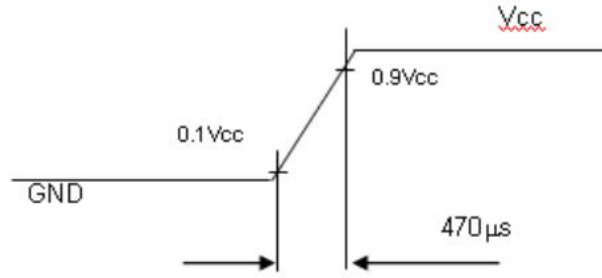

Note (3) The specified power supply current is under the conditions at V_{CC} = 5.0 V, T_a = 25 ± 2 °C, Fr = 75Hz, whereas a power dissipation check pattern below is displayed.

a. White Pattern

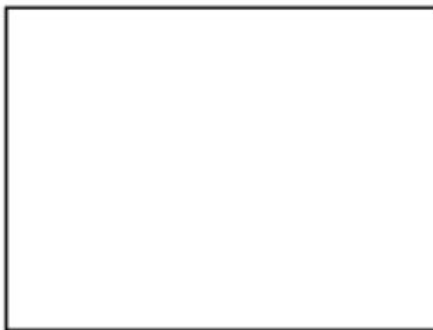

Active Area

b. Black Pattern



Active Area

c. Vertical Stripe Pattern

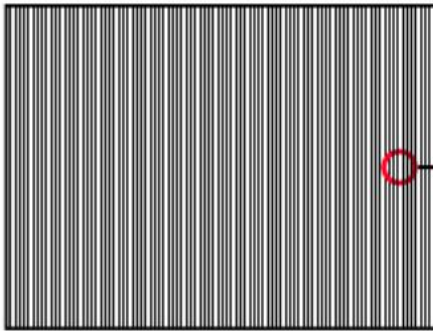

Active Area

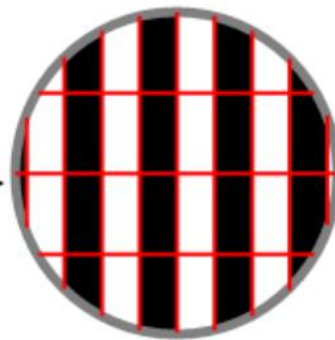

Note (4) The power consumption is specified at the pattern with the maximum current.

Note (5) VID waveform condition

Single-End

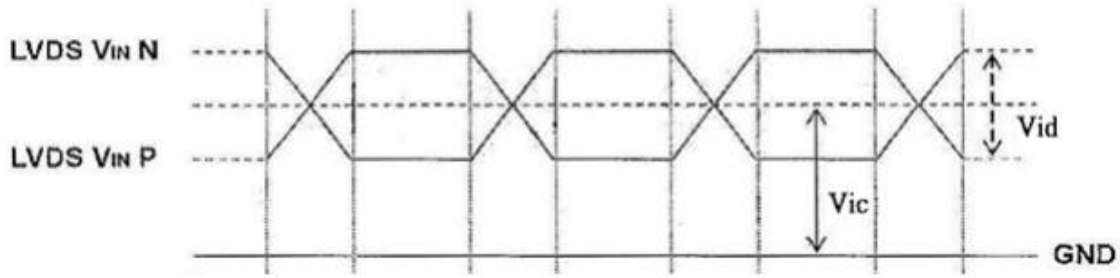

Note (6): PLCD Max. : =5V* Max

4.3.2 BACKLIGHT UNIT

Parameter	Symbol	Value			Unit	Note
		Min.	Typ.	Max.		
LED Light Bar Input Voltage Per Input Pin	VPIN	-	-	36.3	V	(1) Duty=100% IPIN=40mA
LED Light Bar Current Per Input Pin	IPIN	-	-	220	mA	(1),(2) Duty=100%
LED Life Time	LLED		50000		Hrs	(3)
Power Consumption	PBL		-	7.98	W	(1) Duty=100%, IPIN=60mA

Note (1) LED light bar input voltage and current are measured by utilizing a true RMS multimeter as shown below:

Note (2) $PBL(Typ) = IPIN(Typ) \times VPIN(Typ) \times (1)$, $PBL(Max)=IPIN(TYP) \times VPIN(Max) \times (1)$, LED light bar circuit is (11)Series, (7)Parallel.

Note (3) The lifetime of LED is defined as the time when LED packages continue to operate under the conditions at $T_a = 25 \pm 2 \text{ }^\circ\text{C}$ and $I = 65 \text{ mA}$ (per chip) until the brightness becomes $\cong 50\%$ of its original value.

4.3.3 LED DRIVER BOARD CONNECTOR

MODEL:LED-0202

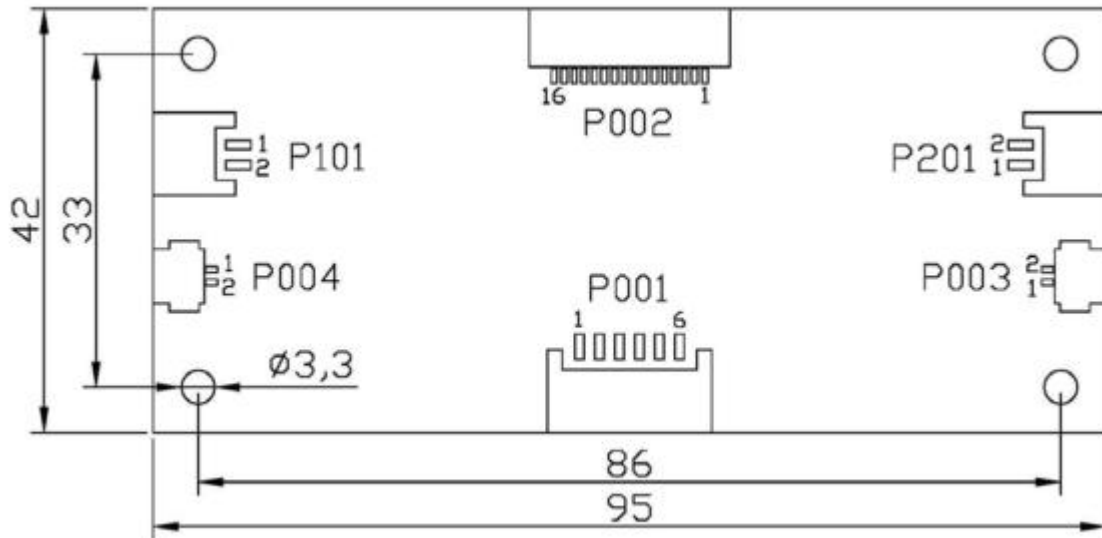

P001: PH2.0-6 (2.0mm X 6)

PIN	SYMBOL	DESCRIPTION
1	V+	12V/24V
2	V+	
3	SW	OFF:0-0.8V / ON:2-VDD
4	ADJ	
5	GND	
6	GND	

P101/201: 2PIN PH2.0-2 (2.0mm X 2)

PIN	SYMBOL	DESCRIPTION
1	LED-	LED2 Current backtrack
2	LED+	LED power supply

4.4 LVDS INPUT SIGNAL SPECIFICATIONS

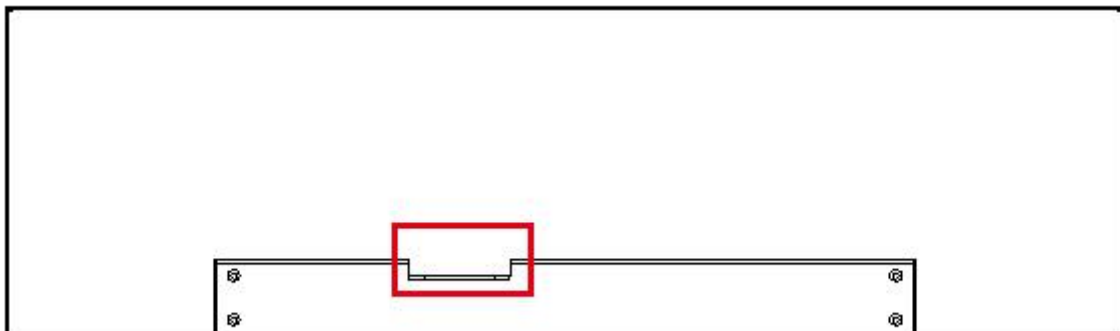

4.4.1 COLOR DATA INPUT ASSIGNMENT

MODEL	HPX172V1	Doc. No		Page	10 / 20
-------	----------	---------	--	------	---------

The brightness of each primary color (red, green and blue) is based on the 8-bit gray scale data input for the color. The higher the binary input, the brighter the color. The table below provides the assignment of color versus data input.

Color		Data Signal																							
		Red								Green								Blue							
		R7	R6	R5	R4	R3	R2	R1	R0	G7	G6	G5	G4	G3	G2	G1	G0	B7	B6	B5	B4	B3	B2	B1	B0
Basic Colors	Black	0	0	0	0	0	0	0	0	0	0	0	0	0	0	0	0	0	0	0	0	0	0	0	0
	Red	1	1	1	1	1	1	1	1	0	0	0	0	0	0	0	0	0	0	0	0	0	0	0	0
	Green	0	0	0	0	0	0	0	0	1	1	1	1	1	1	1	1	0	0	0	0	0	0	0	0
	Blue	0	0	0	0	0	0	0	0	0	0	0	0	0	0	0	0	1	1	1	1	1	1	1	1
	Cyan	0	0	0	0	0	0	0	0	1	1	1	1	1	1	1	1	1	1	1	1	1	1	1	1
	Magenta	1	1	1	1	1	1	1	1	0	0	0	0	0	0	0	0	1	1	1	1	1	1	1	1
	Yellow	1	1	1	1	1	1	1	1	1	1	1	1	1	1	1	1	0	0	0	0	0	0	0	0
	White	1	1	1	1	1	1	1	1	1	1	1	1	1	1	1	1	1	1	1	1	1	1	1	1
Gray Scale Of Red	Red(0) / Dark	0	0	0	0	0	0	0	0	0	0	0	0	0	0	0	0	0	0	0	0	0	0	0	
	Red(1)	0	0	0	0	0	0	0	1	0	0	0	0	0	0	0	0	0	0	0	0	0	0	0	
	Red(2)	0	0	0	0	0	0	1	0	0	0	0	0	0	0	0	0	0	0	0	0	0	0	0	
	⋮	⋮	⋮	⋮	⋮	⋮	⋮	⋮	⋮	⋮	⋮	⋮	⋮	⋮	⋮	⋮	⋮	⋮	⋮	⋮	⋮	⋮	⋮	⋮	
	⋮	⋮	⋮	⋮	⋮	⋮	⋮	⋮	⋮	⋮	⋮	⋮	⋮	⋮	⋮	⋮	⋮	⋮	⋮	⋮	⋮	⋮	⋮	⋮	
	⋮	⋮	⋮	⋮	⋮	⋮	⋮	⋮	⋮	⋮	⋮	⋮	⋮	⋮	⋮	⋮	⋮	⋮	⋮	⋮	⋮	⋮	⋮	⋮	
	Red(253)	1	1	1	1	1	1	0	1	0	0	0	0	0	0	0	0	0	0	0	0	0	0	0	
	Red(254)	1	1	1	1	1	1	1	0	0	0	0	0	0	0	0	0	0	0	0	0	0	0	0	
Red(255)	1	1	1	1	1	1	1	1	0	0	0	0	0	0	0	0	0	0	0	0	0	0	0		
Gray Scale Of Green	Green(0) / Dark	0	0	0	0	0	0	0	0	0	0	0	0	0	0	0	0	0	0	0	0	0	0	0	
	Green(1)	0	0	0	0	0	0	0	0	0	0	0	0	0	0	1	0	0	0	0	0	0	0	0	
	Green(2)	0	0	0	0	0	0	0	0	0	0	0	0	0	1	0	0	0	0	0	0	0	0	0	
	⋮	⋮	⋮	⋮	⋮	⋮	⋮	⋮	⋮	⋮	⋮	⋮	⋮	⋮	⋮	⋮	⋮	⋮	⋮	⋮	⋮	⋮	⋮	⋮	
	⋮	⋮	⋮	⋮	⋮	⋮	⋮	⋮	⋮	⋮	⋮	⋮	⋮	⋮	⋮	⋮	⋮	⋮	⋮	⋮	⋮	⋮	⋮	⋮	
	⋮	⋮	⋮	⋮	⋮	⋮	⋮	⋮	⋮	⋮	⋮	⋮	⋮	⋮	⋮	⋮	⋮	⋮	⋮	⋮	⋮	⋮	⋮	⋮	
	Green(253)	0	0	0	0	0	0	0	1	1	1	1	1	1	1	0	1	0	0	0	0	0	0	0	
	Green(254)	0	0	0	0	0	0	0	1	1	1	1	1	1	1	1	0	0	0	0	0	0	0	0	
Green(255)	0	0	0	0	0	0	0	1	1	1	1	1	1	1	1	0	0	0	0	0	0	0	0		
Gray Scale Of Blue	Blue(0) / Dark	0	0	0	0	0	0	0	0	0	0	0	0	0	0	0	0	0	0	0	0	0	0	0	
	Blue(1)	0	0	0	0	0	0	0	0	0	0	0	0	0	0	0	0	0	0	0	0	0	0	1	
	Blue(2)	0	0	0	0	0	0	0	0	0	0	0	0	0	0	0	0	0	0	0	0	0	1	0	
	⋮	⋮	⋮	⋮	⋮	⋮	⋮	⋮	⋮	⋮	⋮	⋮	⋮	⋮	⋮	⋮	⋮	⋮	⋮	⋮	⋮	⋮	⋮	⋮	
	⋮	⋮	⋮	⋮	⋮	⋮	⋮	⋮	⋮	⋮	⋮	⋮	⋮	⋮	⋮	⋮	⋮	⋮	⋮	⋮	⋮	⋮	⋮	⋮	
	⋮	⋮	⋮	⋮	⋮	⋮	⋮	⋮	⋮	⋮	⋮	⋮	⋮	⋮	⋮	⋮	⋮	⋮	⋮	⋮	⋮	⋮	⋮	⋮	
	Blue(253)	0	0	0	0	0	0	0	0	0	0	0	0	0	0	0	1	1	1	1	1	1	1	0	
	Blue(254)	0	0	0	0	0	0	0	0	0	0	0	0	0	0	0	1	1	1	1	1	1	1	0	
Blue(255)	0	0	0	0	0	0	0	0	0	0	0	0	0	0	0	1	1	1	1	1	1	1	1		

Note (1) 0: Low Level Voltage, 1: High Level Voltage

4.5 DISPLAY TIMMING SPECIFICATIONS

The input signal timing specifications are shown as the following table and timing diagram.

Signal	Item	Symbol	Min.	Typ.	Max.	Unit	Note
Frequency	Clock	Fc	50	75.4	95	MHz	-
	Hsync	Fh	39.4	48.4	55	KHz	
	Vsync	Fv	50	60	75	Hz	
Vertical Display Term	Total	Tv	778	806	888	Th	Tv=Tvd+Tvb
	Active Display	Tvd	768	768	768	Th	-
	Blank	Tvb	Tv-Tvd	38	Tv-Tvd	Th	-
Horizontal Display Term	Total	Th	1446	1560	1936	Tc	Th=Thd+Thb
	Active Display	Thd	1366	1366	1366	Tc	-
	Blank	Thb	Th-Thd	194	Th-Thd	Tc	-

Note: Because this module is operated by DE only mode, Hsync and Vsync input signals are ignored.

INPUT SIGNAL TIMING DIAGRAM

MODEL	HPX172V1	Doc. No		Page	11 / 20
-------	----------	---------	--	------	---------

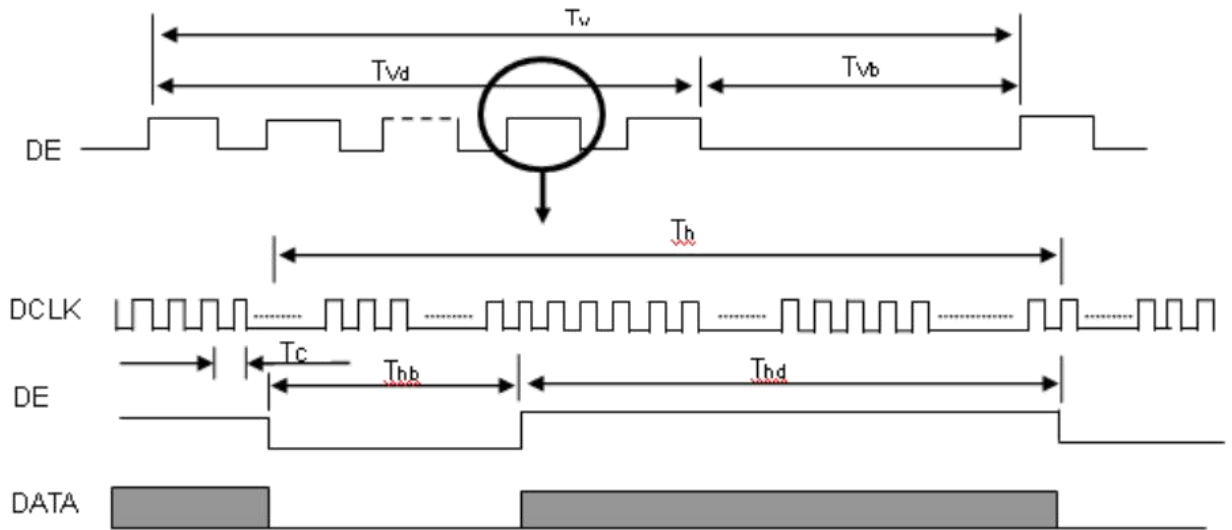

Note (1) The input clock cycle-to-cycle jitter is defined as below figures. $Trcl = |T_1 - T_1|$

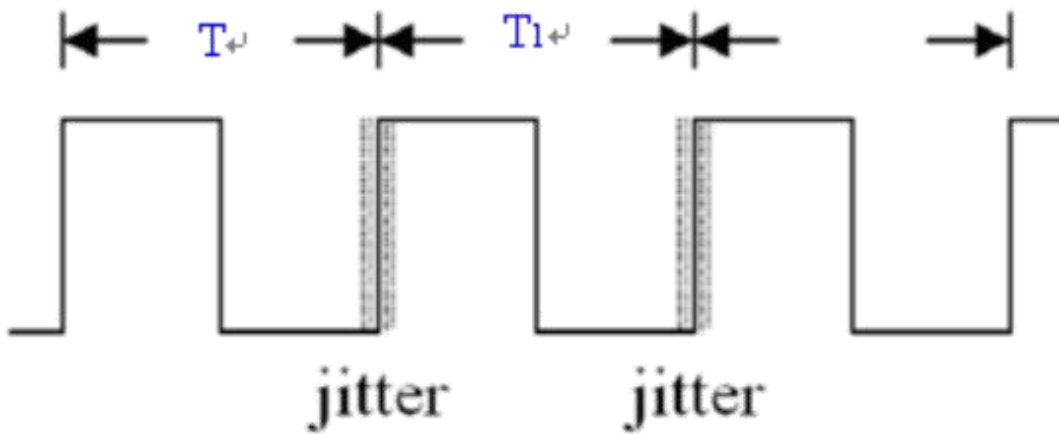

Note (2) Input Clock to data skew is defined as below figures.

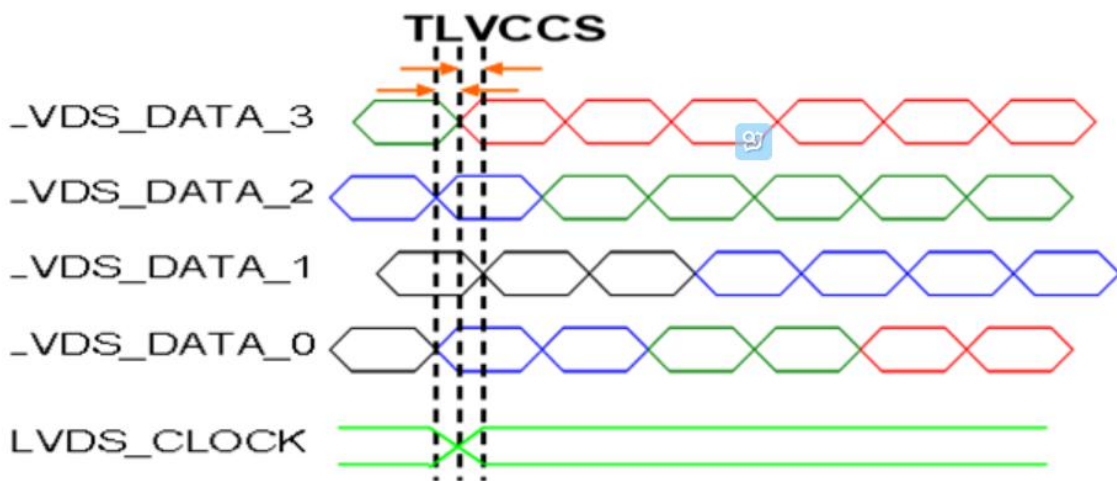

Note (3) The SSCG (Spread spectrum clock generator) is defined as below figures.

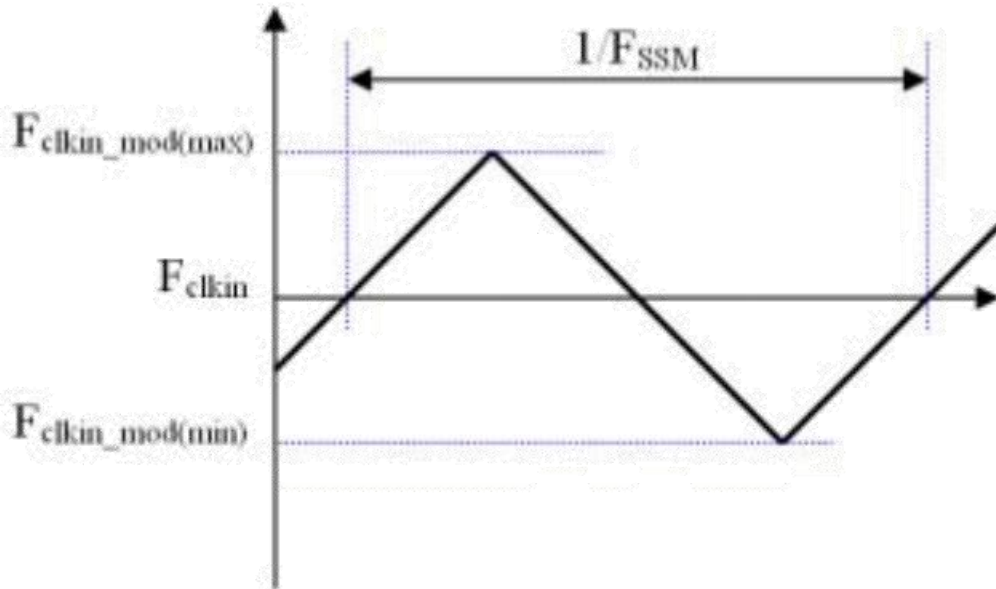

Note(4) The DCLK range at last line of V-blank should be set in 0 to Hdisplay/2

4.6 POWER ON/OFF SEQUENCE

The power sequence specifications are shown as the following table and diagram.

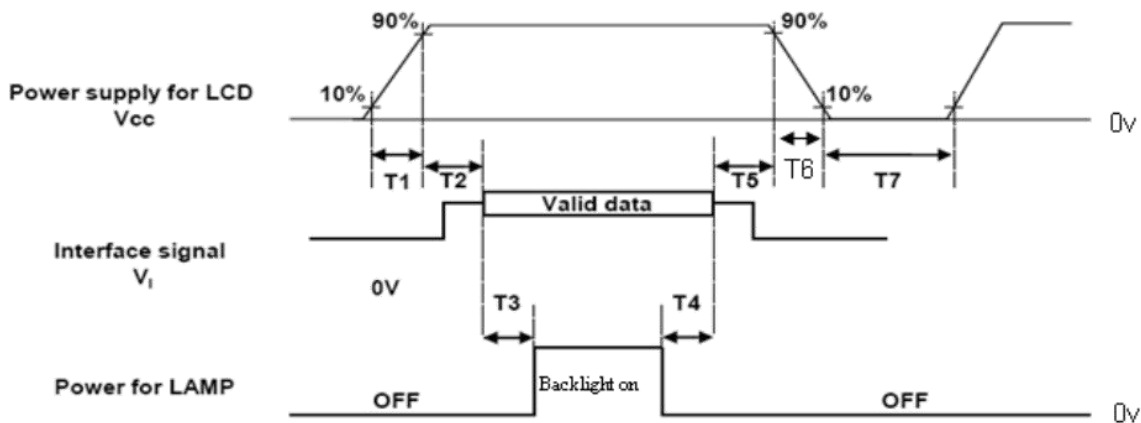

Parameters	Values			Units
	Min.	Typ.	Max.	
T1	0.5	-	10	ms
T2	0	-	50	ms
T3	500	-	-	ms
T4	100	-	-	ms
T5	0	-	50	ms
T6	5	-	100	ms
T7	1000	-	-	ms

Note (1) The supply voltage of the external system for the module input should be the same as the definition of Vcc.

Note (2) When the backlight turns on before the LCD operation of the LCD turns off, the display may

momentarily become abnormal screen.

Note (3) In case of VCC = off level, please keep the level of input signals on the low or keep a high impedance.

Note (4) T7 should be measured after the module has been fully discharged between power off and on period.

Note (5) Interface signal shall not be kept at high impedance when the power is on.

Note (6) CMI won't take any responsibility for the products which are damaged by the customers not following the Power Sequence.

Note (7) There might be slight electronic noise when LCD is turned off (even backlight unit is also off). To avoid this symptom, we suggest "Vcc falling timing" to follow "t6 spec".

5. OPTICAL CHARACTERISTICS

5.1 TEST CONDITIONS

Item	Symbol	Value	Unit
Ambient Temperature	Ta	25±2	°C
Ambient Humidity	Ha	50±10 %R	%RH
Supply Voltage	Vcc	5	
Input Signal	According to typical value in "3. ELECTRICAL CHARACTERISTICS"		
LED Light Bar Input Current Per Input Pin	IPIN	40 ± 1.95	mADC
PWM Duty Ratio	D	mADC	%

5.2 OPTICAL SPECIFICATIONS

The relative measurement methods of optical characteristics are shown in 5.2. The following items should be measured under the test conditions described in 5.1 and stable environment shown in Note (5).

Item	Symbol	Condition	Min.	Typ.	Max.	Unit	Note	
Color Chromaticity (CIE)	Red	Rx	Normal $\theta_x=0^\circ$, $\theta_Y=0^\circ$ Viewing Angle	Typ – 0.03	TBD	Typ + 0.03	-	(1),(5)
		Ry			TBD			
	Green	Gx			TBD			
		Gy			TBD			
	Blue	Bx			TBD			
		By			TBD			
	White	Wx			TBD			
		Wy			TBD			
Center Luminance of White (Center of Screen)	LC		400	500	-	cd/m2	(4),(5)	
Contrast Ratio	CR		900	1200	-	-	(2),(5)	
Response Time	G-to-G	$\theta_x=0^\circ$, $\theta_Y=0^\circ$	-	8	10	ms	(3)	

White variation		δW	$\theta_x=0^\circ, \theta_y=0^\circ$	75	80	-	(5),(6)
Viewing Angle	Horizontal	$\theta_{x-} + \theta_{x+}$	$CR \cong 10$	85	89	-	Deg. (1),(5)
	Vertical	$\theta_{y-} + \theta_{y+}$		85	89	-	
Viewing Angle	Horizontal	$\theta_{x-} + \theta_{x+}$	$CR \cong 5$	85	89	-	Deg. (1),(5)
	Vertical	$\theta_{y-} + \theta_{y+}$		85	89	-	

Note (1) Definition of Viewing Angle (θ_x, θ_y):

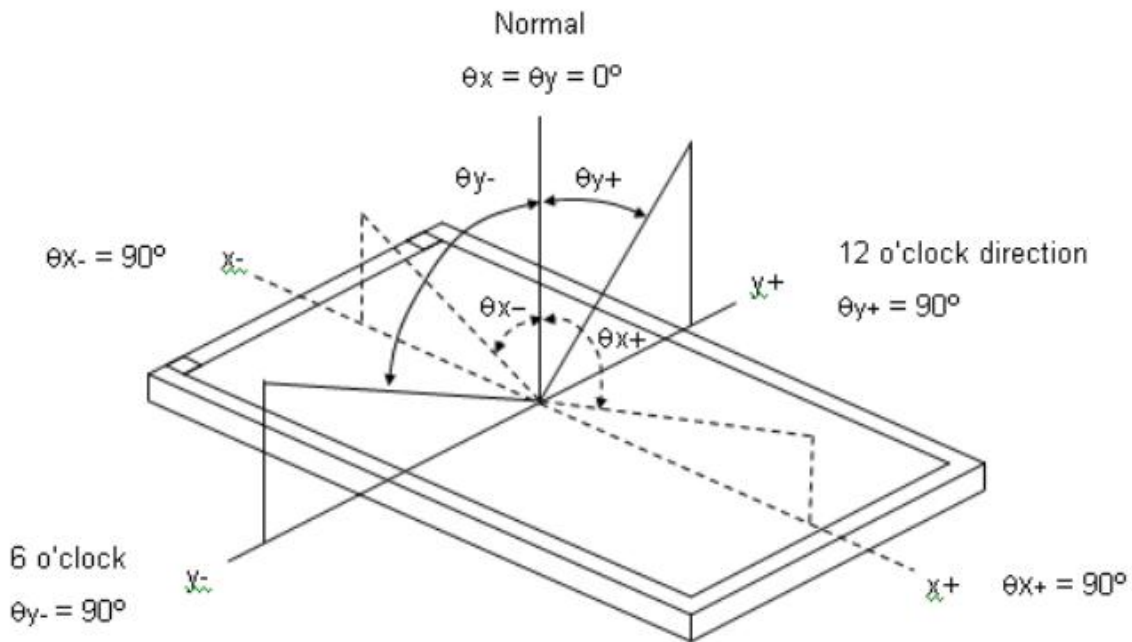

Note (2) Definition of Contrast Ratio (CR):

The contrast ratio can be calculated by the following expression.

$$\text{Contrast Ratio (CR)} = L_{255} / L_0$$

L255: Luminance of gray level 255

L 0: Luminance of gray level 0

$$CR = CR (5)$$

CR (X) is corresponding to the Contrast Ratio of the point X at Figure in Note (6).

Note (3) Definition of Response Time (T_R, T_F):

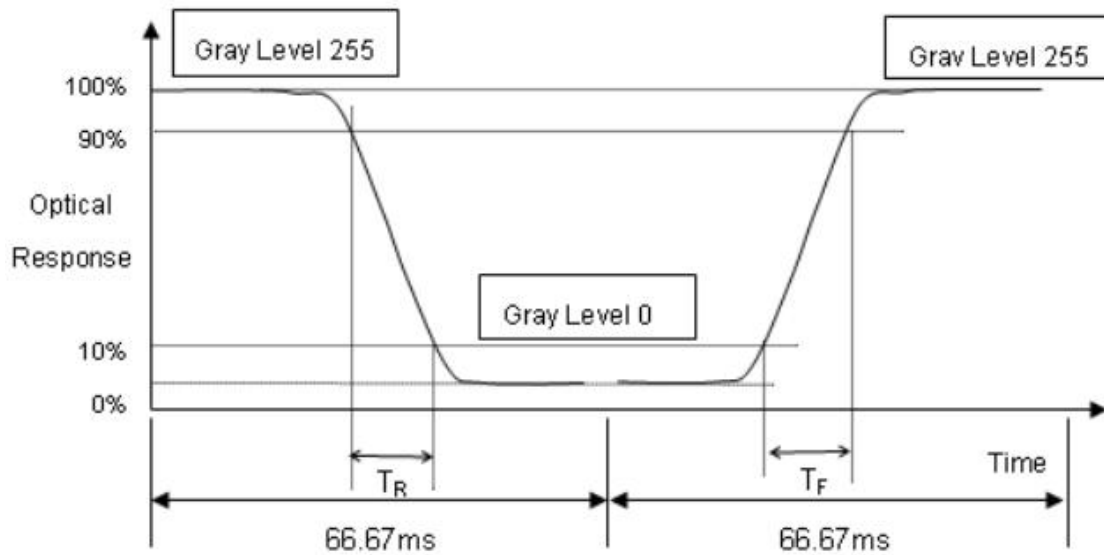

Note (4) Definition of Luminance of White (Lc):

Measure the luminance of gray level 255 at center point

$$L_c = L(5)$$

L(x) is corresponding to the luminance of the point X at Figure in Note (6).

Note (5) Measurement Setup:

The LCD module should be stabilized at given temperature for 40 minutes to avoid abrupt temperature change during measuring. In order to stabilize the luminance, the measurement should be executed after lighting Backlight for 40 minutes in a windless room.

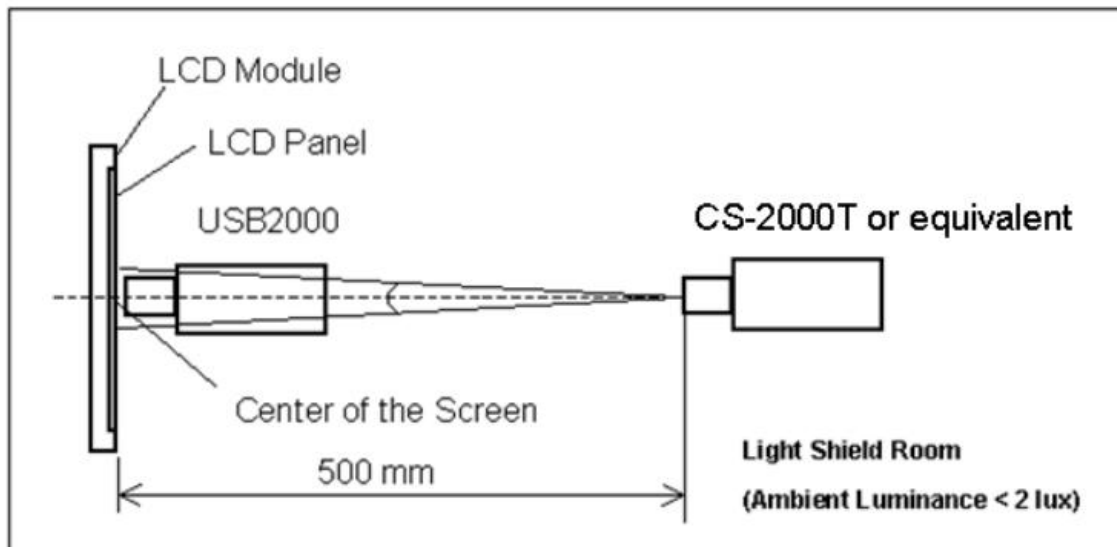

Note (6) Definition of White Variation (δW):

Measure the luminance of gray level 255 at 9 points

$$\delta W = (\text{Minimum } [L(1) \sim L(9)] / \text{Maximum } [L(1) \sim L(9)]) * 100\%$$

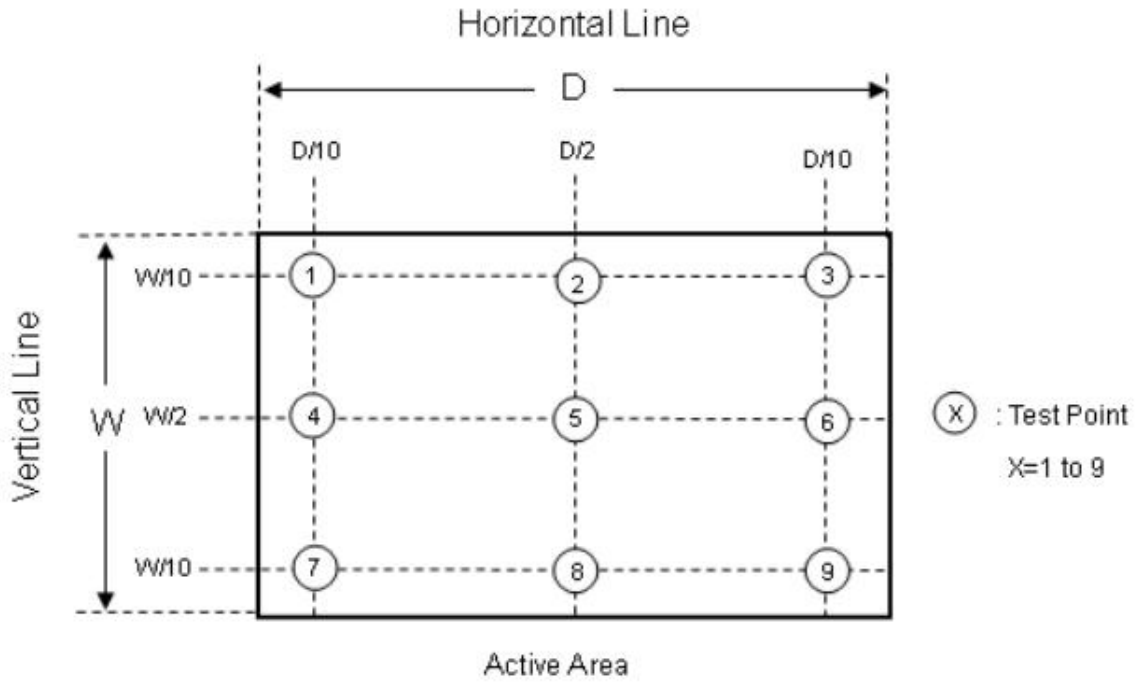

6. RELIABILITY TEST ITEM

Item	Required Condition	Note
Temperature Humidity Bias (THB)	Ta= 50°C , 80%RH, 240hours	
High Temperature Operation (HTO)	Ta= 50°C , 240hours	
Low Temperature Operation (LTO)	Ta= 0°C , 240hours	
High Temperature Storage (HTS)	Ta= 60°C , 240hours	
Low Temperature Storage (LTS)	Ta= -20°C , 240hours	
Vibration Test (Non-operation)	Acceleration: 1.5 G Wave: Sine Frequency: 10 - 300 Hz Sweep: 30 Minutes each Axis (X, Y, Z)	
Shock Test (Non-operation)	Acceleration: 50 G Wave: Half-sine Active Time: 11 ms Direction : ± X, ± Y, ± Z.(one time for each Axis)	
Thermal Shock Test (TST)	-20°C /30min , 60°C / 30min , 100 cycles	
On/Off Test	25°C , On/10sec , Off /10sec , 30,000 cycles	
ESD (Electro Static Discharge)	Contact Discharge: ± 8KV, 150pF(330Ω) Air Discharge: ± 15KV, 150pF(330Ω)	
Altitude Test	Operation:10,000 ft / 24hours Non-Operation:30,000 ft / 24hours	

Note (1) criteria : Normal display image with no obvious non-uniformity and no line defect.

Note (2) Evaluation should be tested after storage at room temperature for more than two hour

Note (3) At testing Vibration and Shock, the fixture in holding the module has to be hard and rigid enough so that the module would not be twisted or bent by the fixture.

The fixing condition is shown as below:

MODEL	HPX172V1	Doc. No		Page	17 / 20
--------------	-----------------	----------------	--	-------------	----------------

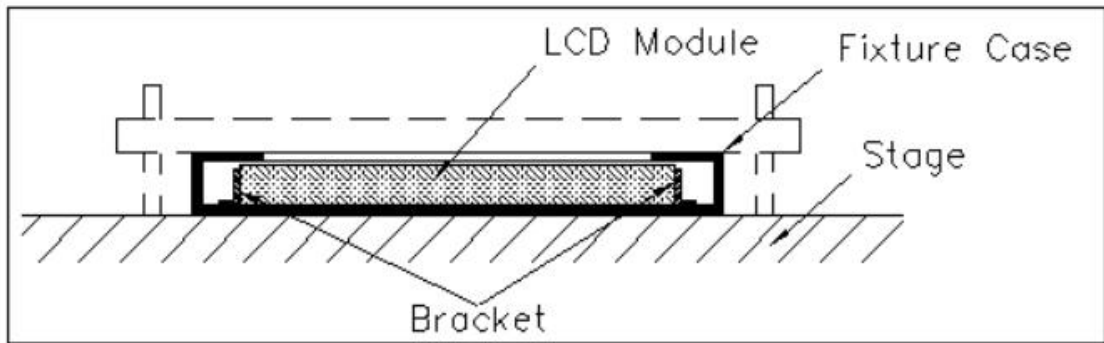

7. PACKING

TBD.

8. MODULE LABEL

TBD.

9. PRECAUTIONS

9.1 ASSEMBLY AND HANDLING PRECAUTIONS

- (1) Do not apply rough force such as bending or twisting to the module during assembly.
- (2) To assemble or install module into user's system can be only in clean working areas. The dust and oil may cause electrical short or worsen the polarizer.
- (3) It's not permitted to have pressure or impulse on the module because the LCD panel and Backlight will be damaged.
- (4) Always follow the correct power sequence when LCD module is connecting and operating. This can prevent damage to the CMOS LSI chips during latch-up.
- (5) Do not pull the I/F connector in or out while the module is operating.
- (6) Do not disassemble the module.
- (7) Use a soft dry cloth without chemicals for cleaning, because the surface of polarizer is very soft and easily scratched.
- (8) It is dangerous that moisture come into or contacted the LCD module, because moisture may damage LCD module when it is operating.
- (9) High temperature or humidity may reduce the performance of module. Please store LCD module within the specified storage conditions.
- (10) When ambient temperature is lower than 10°C may reduce the display quality. For example, the response time will become slowly.

9.2 STORAGE PRECAUTIONS

- (1) Do not leave the module in high temperature, and high humidity for a long time. It is highly recommended to store the module with temperature from 0°C to 35°C and relative humidity of less than 70%
- (2) Do not store the TFT – LCD module in direct sunlight
- (3) The module should be stored in dark place. It is prohibited to apply sunlight or fluorescent light in storing

MODEL	HPX172V1	Doc. No		Page	18 / 20
--------------	-----------------	----------------	--	-------------	----------------

9.3 OPERATION PRECAUTIONS

- (1) The LCD product should be operated under normal condition.
Normal condition is defined as below :
Temperature : $20\pm 15^{\circ}\text{C}$
Humidity: $65\pm 20\%$
Display pattern : continually changing pattern(Not stationary)
- (2) If the product will be used in extreme conditions such as high temperature,high humidity,high altitude ,display pattern or operation time etc...It is strongly recommended to contact CMI for application engineering advice . Otherwise , Its reliability and function may not be guaranteed.

9.4 SAFETY PRECAUTIONS

- (1) If the liquid crystal material leaks from the panel, it should be kept away from the eyes or mouth. In case of contact with hands, skin or clothes, it has to be washed away thoroughly with soap.
- (2) After the module's end of life, it is not harmful in case of normal operation and storage.

9.5 SAFETY STANDARDS

The LCD module should be certified with safety regulations as follows:

- (1) UL60950-1 or updated standard.
- (2) IEC60950-1 or updated standard.

9.6 OTHER

When fixed patterns are displayed for a long time ,remnant image is likely to occur.

Appendix. OUTLINE DRAWING

MODEL	HPX172V1	Doc. No		Page	19 / 20
-------	----------	---------	--	------	---------

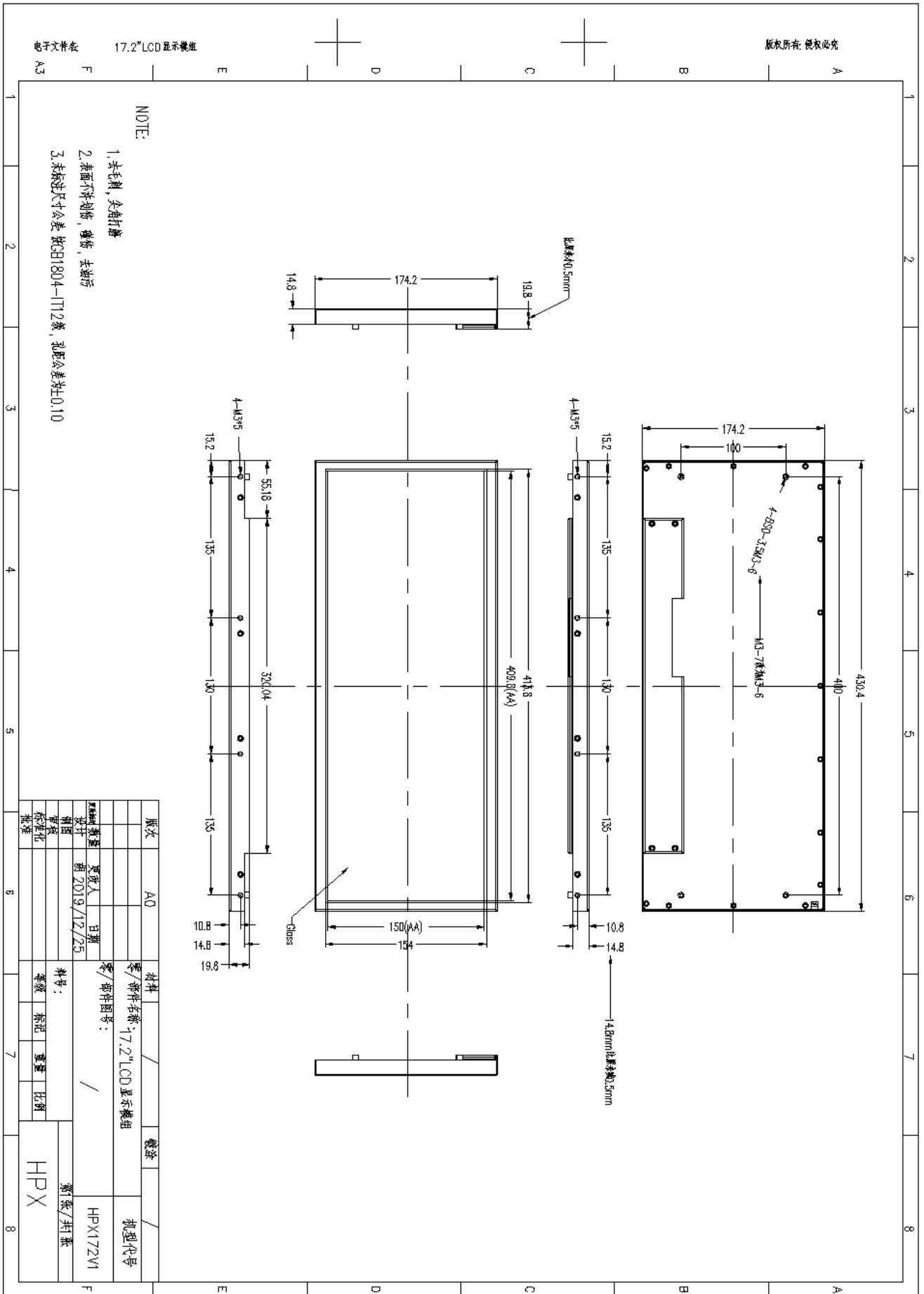

版次	A.0	材料	/	镀涂	/	机型代号	HPX172V1
零件名称	17.2"LCD显示模组			零件图号	/	料号	HPX172V1
数量	1	日期	2019/12/25	等级	标准	变更	比例
设计	审核	批准					HPX