



深圳市福瑞达显示技术有限公司  
SHENZHEN FRIDA LCD CO.,LTD

Doc No: FRD350H54004-C-CTK

REV: A

PAGE: 1/17

SPEC TITLE  
DOCUMENT CONTROL SPECIFICATION

EFFECTIVE DATE: 2018-10-17

# PRODUCT SPECIFICATION

## TFT-LCD MODULE

Model No: FRD350H54004-C-CTK

For Customer's Acceptance	
Approved by	Comment

	Signature	Date
Prepared by	 李三亮 深援武 2018.10.17	2018.10.17
Checked by		2018.10.17
Approved by		2018.10.17

深圳市福瑞达显示技术有限公司

地址: 深圳市光明新区公明田寮第二工业区田荣路 68 号

Add: The 68th, Tianrong Road, Tianliao Community, Gongming Town, Guangming new district, shenzhen.

电话(Tel): (0755)33563741 (0755)33563743

传真(Fax): (0755)29351371

网址(Web): www.fridalcd.com



## Contents

No.	ITEM
<b>1</b>	<b>Document Revision History</b>
<b>2</b>	<b>General Description</b>
<b>3</b>	<b>Outline Dimension</b>
<b>4</b>	<b>Interface Specification</b>
<b>5</b>	<b>Absolute Maximum Ratings</b>
<b>6</b>	<b>Electrical Specifications</b>
<b>7</b>	<b>Timing Characteristics</b>
<b>8</b>	<b>Optical Specification</b>
<b>9</b>	<b>Reliability Test Items</b>
<b>10</b>	<b>Precautions</b>



### 1. Document Revision History :

DOCUMENT REVISION	DATE	DESCRIPTION	PREPARED BY
A	2018-10-17	First Release.	



## 2. General Description

No	Item	Specification	Remark
1	Screen Size	3.5 inch	
2	Display Mode	Normally Black	
3	Resolution	320 × RGB × 240	
4	Active Area	70.08*52.56	mm
5	Outline Dimension	77.0*64.02*4.5	mm
6	Viewing Direction	ALL	
7	Driver IC	ST7272A-G4-1-H	
8	Interface	RGB	
9	Back Light	White Led*6	
10	Touch Panel	CTP	





## 4. Interface Specification

Pin No	Symbol	Description	Note
1-2	LEDK	Power Supply For LED Backlight Cathode Input.	
3-4	LEDA	Power Supply For LED Backlight Anode Input.	
5	YU(Y+)	touch panel. UP	
6	XR(X+)	touch panel. RIGHT	
7	NC	No Connection.	
8	RESET	Reset Signal input pin.	
9	SPENA (CS)	Chip selection signal pin.	
10	SPCLK (SCL)	Serial clock signal pin.	
11	SPDAT (SDA)	Serial data input/output pin.	
12-19	B0-B7	Blue data (B0-LSB;B7-MSB)	
20-27	G0-G7	Green data (G0-LSB; G7-MSB)	
28-35	R0-R7	Red data (R0-LSB;R7-MSB)	
36	HSYNC	Line synchronous signal for RGB interface operation.	
37	VSYNC	Frame synchronous signal for RGB interface operation.	
38	DOTCLK	Dot clock signal for RGB interface operation.	
39-40	AVDD(NC)	No Connection.	
41	VCCIO	Power supply for digital I/O pin	
42	VCC	Power Supply For LCD.	
43	YD(Y-)	touch panel. DOWN	
44	XL(X-)	touch panel. Left	
45	VGL(NC)	No Connection.	
46	NC	No Connection.	
47	VGH(NC)	No Connection.	
48	SEL2	No Connection.	
49	SEL1	No Connection.	
50	SEL0	No Connection.	
51	YU(NC)	No Connection.	
52	DEN	Data enable signal for RGB interface operation.	



53	DGND	Ground.	
54	AVSS	Ground.	

#### 4.1 CTP Interface Specification

1	GND	System Ground	
2	INT	External interrupt to the host	
3	SDA	Serial data input signal	
4	SCL	Serial clock signal	
5	REST	External Reset, active low	
6	VDD3.3V	Power supply input for CTP: 2.8V	

#### 5. Absolute Maximum Ratings

##### Electrical Maximum Ratings – for IC Only

Parameter	Symbol	Min.	Max.	Unit	Note
Power supply voltage (VCC)	VCC	-0.3	+4.0	V	1
Power supply voltage (IOVCC)	IOVCC	-0.3	+4.0	V	1

Note:

- 1.VCC,IOVCC, GND must be maintained.
- 2.The modules may be destroyed if they are used beyond the absolute maximum ratings.

#### 6. Electrical Specifications

At Ta = 25 °C, VCC = 3.0V to 3.6V, IOVCC = 3.0V to 3.6V, GND=0V.

Parameter	Symbol	Conditions	Min.	Typ.	Max.	Unit
Supply voltage (analog)	VCC-GND		3.0	3.3	3.6	V
Supply voltage (Logic)	IOVCC-GND		3.0	-	3.6	V
Supply current (Logic & LCD)	ICC		-	-	-	mA
Supply voltage of white LED backlight	VLED	Forward current =20mA Number of LED = 6	16.2	18.0	19.8	V

## 7. Timing Characteristics

### 7.1 System Bus Timing for 3-Wire SPI Interface

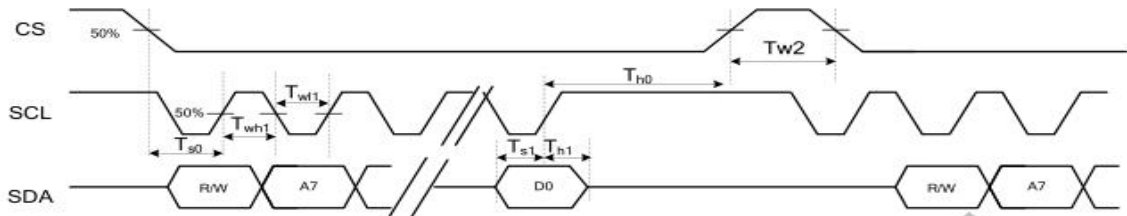

Item	Symbol	Min.	Typ.	Max.	Unit	Conditions
CS Input Setup Time	Ts0	50	-	-	ns	
Serial Data Input Setup Time	Ts1	50	-	-	ns	
CS Input Hold Time	Th0	50	-	-	ns	
Serial Data Input Hold Time	Th1	50	-	-	ns	
SCL Write Pulse High Width	Twh1	50	-	-	ns	
SCL Write Pulse Low Width	Tlw1	50	-	-	ns	
SCL Read Pulse High Width	Trh1	300			ns	
SCL Read Pulse Low Width	Trl1	300			ns	
CS Pulse High Width	Tw2	400	-	-	ns	

### 7.2 System Bus Timing for RGB Interface

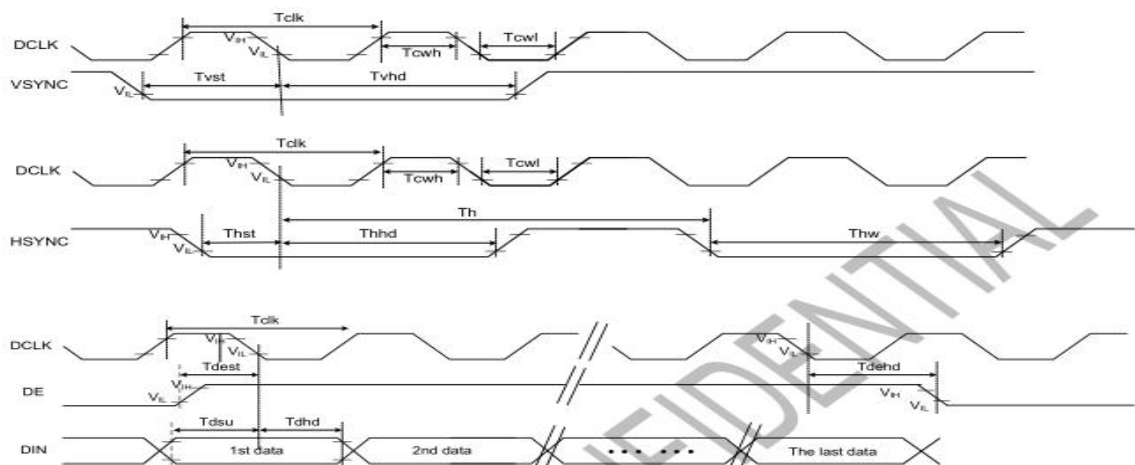

Item	Symbol	Min.	Typ.	Max.	Unit	Conditions
CLK Pulse Duty	Tclk	40	50	60	%	
HSYNC Width	Thw	2	-	-	DCLK	
HSYNC Period	Th	55	60	65	us	
VSYNC Setup Time	Tvst	12	-	-	ns	
VSYNC Hold Time	Tvhd	12	-	-	ns	
HSYNC Setup Time	Thst	12	-	-	ns	
HSYNC Hold Time	Thhd	12	-	-	ns	
Data Setup Time	Tdsu	12	-	-	ns	
Data Hold Time	Tdhd	12	-	-	ns	
DE Setup Time	Tdest	12	-	-	ns	
DE Hold Time	Tdehd	12	-	-	ns	



## 8. Power Supply Configuration

### 8.2 Power On Sequence

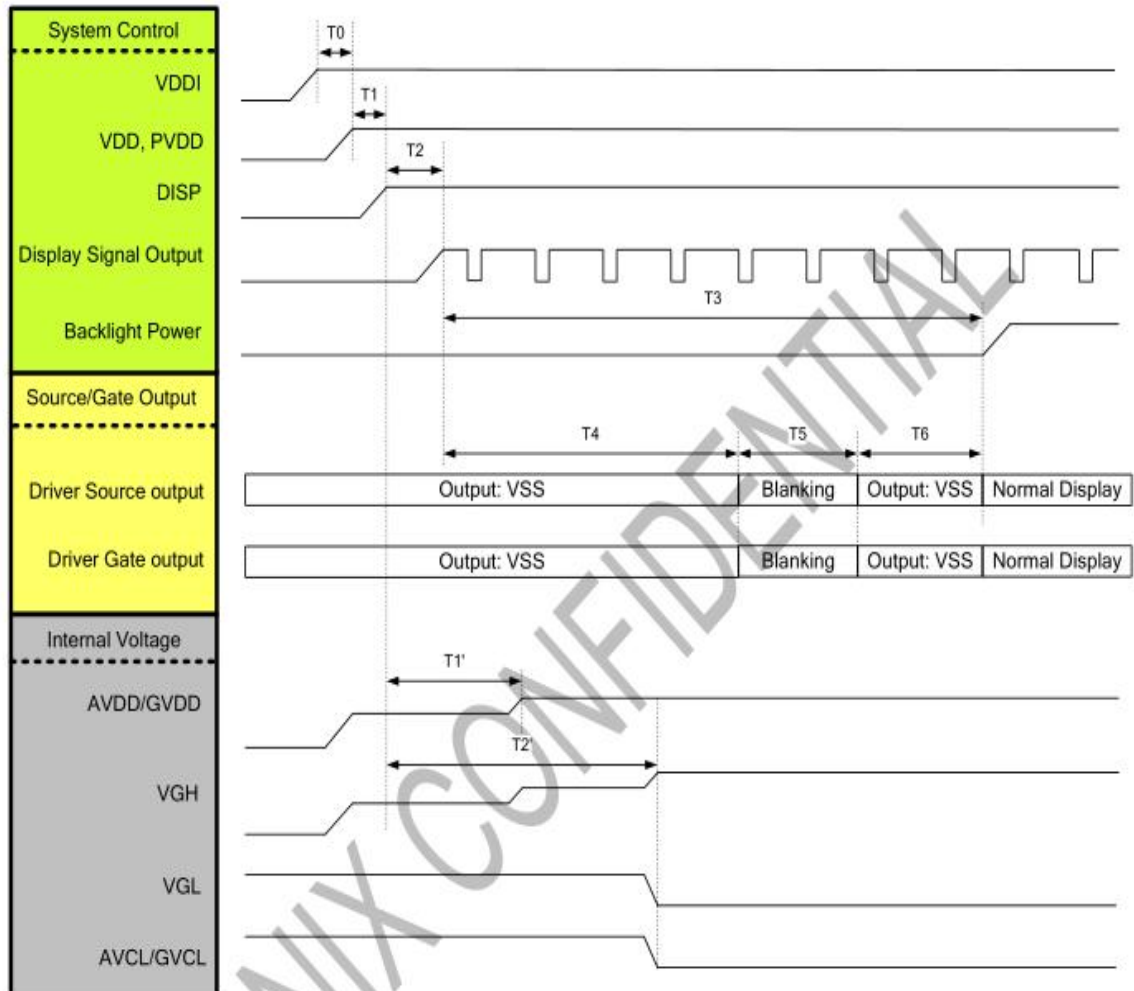

Symbol	Description	Min. Time	Unit
T0	Analog power on delay time	0	ms
T1	System power stability to DISP= "High"	0	ms
T2	DISP= "High" to display signal output	10	ms
T3	Display signal output to backlight power on	250	ms
T4	Display signal output to source output	100	ms
T5	Source/ Gate blanking time	30	ms
T6	Source/ Gate automatic output VSS	80	ms
T1'	DISP= "High" to AVDD/GVDD voltage stable time	20	ms
T2'	DISP= "High" to VGH/VGL/AVCL/GVCL voltage stable time	60	ms

### 8.3 Power Off Sequence

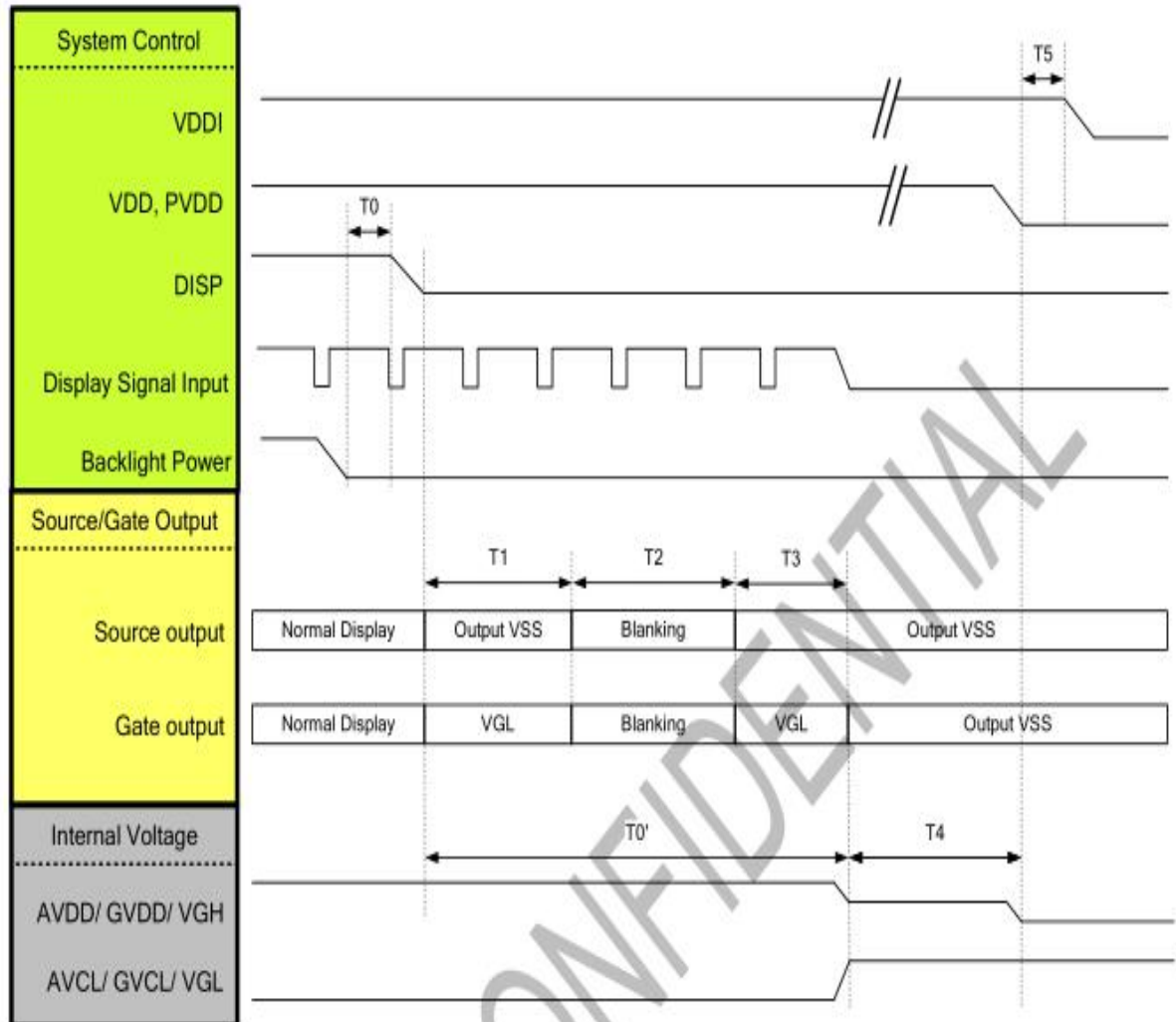

Symbol	Description	Min. Time	Unit
T0	Backlight power off to DISP off	5	ms
T1	Source voltage output VSS and Gate voltage output VGL	30	ms
T2	Source/ Gate blanking time	30	ms
T3	Source voltage output VSS and Gate voltage output VGL	20	ms
T4	AVDD/ GVDD/ VGH discharge time	5	ms
T5	Analog power off to digital power off time	0	ms
T0'	Source and Gate voltage discharge complete width	80	ms



## 9.Optical Specification

Item 项目	Symbol 符号	Condition 条件	Min 最小值	Typ 典型值	Max 最大值	Unit 单位	Note 备注
Response time 响应时间	Tr+Tf	$\Theta=0^{\circ}$ $\emptyset=0^{\circ}$ Ta=25°C	-	30	40	ms	1
Contrast ratio 对比度	Cr		640	800	-	-	2
Color gamut 饱和度	S(%)		55	60	-	%	-
Luminance uniformity 均匀度	$\delta$ WHITE		80	-	-	%	3
Viewing angle range 视角范围	$\Theta_{x+}$	CR $\geq$ 10 Ta=25°C	-	80	-	deg	4
	$\Theta_{x-}$		-	80	-	deg	
	$\Theta_{y+}$		-	80	-	deg	
	$\Theta_{y-}$		-	80	-	deg	
LCM Luminance LCM 亮度	Lv	$\Theta=0^{\circ}$ $\emptyset=0^{\circ}$ Ta=25°C	-	TBD	-	Cd/m <sup>2</sup>	5
CIE (X,Y) Chromaticity 色度坐标	White(X)		-	-	-	-	6
	White(Y)		-	-	-	-	

Note1.Response time is the time required for the display to transition from White to black(Rise Time,Tr)and from black to white(Decay Time,Tf).For additional information see FIG1...

Note2.contrast Ratio(CR) is defined mathematically by the following formula ,For more information see FIG2.

Contrast Ratio(CR)=Average Surface Luminance with all white pixels/ Average Surface Luminance with all black pixels

Note3.The uniformity in surface luminance(WHITE) is determined by measuring luminance at each test position,and then dividing the maximum luminance of all white pixels by minimum luminance of all white pixels,For more information seeFIG2.

WHITE=Minimum Surface Luminance with all white pixels(P1,P2,.....)/Maximum Surface Luminance with all white pixels(P1,P2,.....)

Note4.Viewing angle is the angel at which contrast ratio is greater than a specific value.For TET module,the specific value of contrast ratio is 10.For monochrome and color stn module,the specific value of contrast ratio is2.The angles are determined for the horizontal or x axis and the vertical or y axis with respect to the z axis which is normal to the LCD surface.For more information see FIG3

Note5. Surface luminance is the LCD surface luminance with all white pixels,For more information see FIG2.

LV=Average Surface Luminance with all white pixels(P1,P2,.....)

Note6.CIE(X,Y)chromaticity is the Center point value.For more information see FIG2.

Note7.For Viewing angle and response time testing,the testing date is base on Autronic-Melchers' s ConScope.Series instruments.For contrast ratio,Surface Luminance,Luminance uniformity and CIE,the testing date is base on CS-2000 photo detector.

Note8.For TN type TFT transmissive module,Gray scale reverse occurs in the direction of panel viewing angle

FIG1. The definition of Response time

响应时间定义



FIG2. Measuring method for Contrast ratio,surface luminance,Luminance

uniformity,CIE(X,Y)chromaticity.

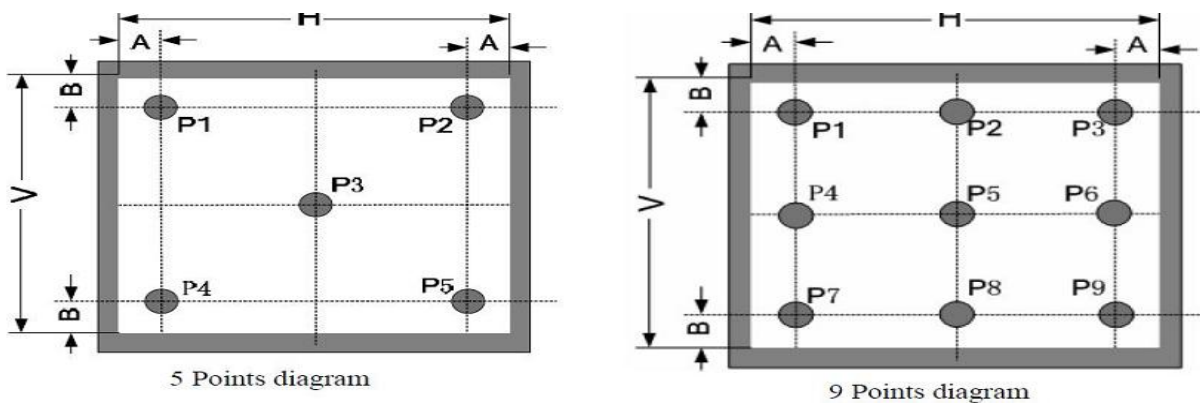
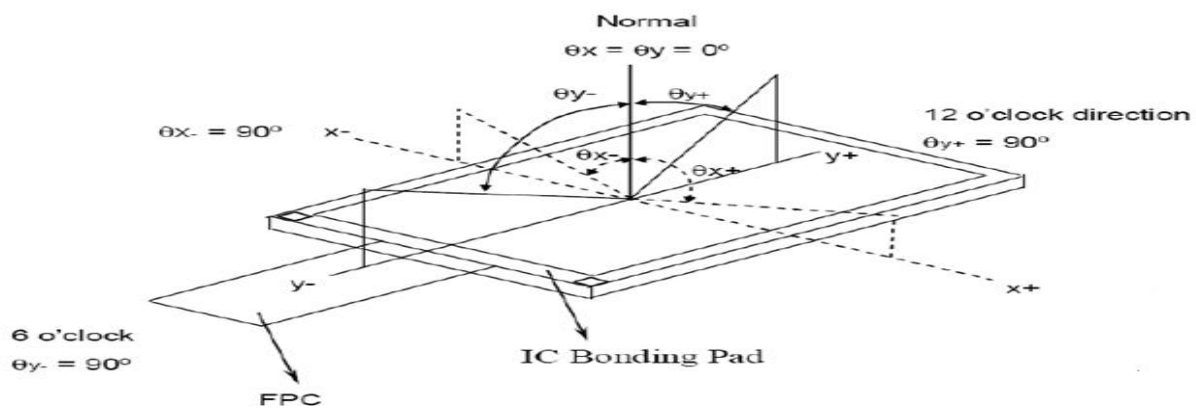

FIG3 The definition of viewing angle 视角定义





## 10. Reliability Test Items

Item	Test Condition	Criterion
High Temperature Storage	70 °C, 48 hrs	Note1,Note2
Low Temperature Storage	-20 °C, 48 hrs	
High Temp. & High Humidity Storage	40 °C, 80% RH, 48hrs	
Thermal Shock (Static)	-20°C, 30 min /70°C, 30 min, 20 cycles	
High Temperature Operation	60 °C, 48 hrs	
Low temperature Operation	-10 °C, 48 hrs	

Note1: Evaluation should be tested after storage at room temperature for two hours.

Note2:

Pass: Normal display image no line defect.

Fail: No display image, or line defects.

Partial transformation of the module parts should be ignored.

## 11. Precautions

Please pay attentions to the followings as using the LCD module.

### Handling

- (a) Do not apply strong mechanical stress like drop, shock or any force to LCD module. It may cause improper operation, even damage.
- (b) Because the polarizer is very fragile and easy to be damaged, do not hit, press or rub the display surface with hard materials.
- (c) Do not put heavy or hard material on the display surface, and do not stack LCD modules.
- (d) If the display surface is dirty, please wipe the surface softly with cotton swab or clean cloth.



- (e) Avoid using Ketone type materials (e.g. Acetone), Toluene, Ethyl acid or Methyl chloride to clean the display surface. It might damage the touch panel surface permanently. The recommended solvents are water and Isopropyl alcohol.
- (f) Wipe off water droplets or oil immediately.
- (g) Protect the LCD module from ESD. It will damage the LSI and the electronic circuit.
- (h) Do not touch the output pins directly with bare hands.
- (i) Do not disassemble the LCD module.
- (j) Do not lift the FPC of Touch Panel.

### **Storage**

- (a) Do not leave the LCD modules in high temperature, especially in high humidity for a long time.
- (b) Do not expose the LCD modules to sunlight directly.
- (c) The liquid crystal is deteriorated by ultraviolet. Do not leave it in strong ultraviolet ray for a long time.
- (d) Avoid condensation of water. It may cause improper operation.
- (e) Please stack only up to the number stated on carton box for storage and transportation. Excessive weight will cause deformation and damage of carton box.

### **Operation**

- (a) When mounting or dismounting the LCD modules, turn the power off.
- (b) Protect the LCD modules from electric shock.
- (c) The Driver IC control algorithms stated above should always obeyed to avoid damaging the LSI and electronic circuit.
- (d) Be careful to avoid mixing up the polarity of power supply for backlight.
- (e) Absolute maximum rating specified above has to be always kept in any case. Exceeding it may cause non-recoverable damage of electronic components or, nevertheless, burning.
- (f) When a static image is displayed for a long time, remnant image is likely to occur.
- (g) Be sure to avoid bending the FPC to an acute shape, it might break FPC.
- (h) Most of the touch screens have air vent to equalize the inside air pressure to the outside one. The air vent must be open and liquid contact must be avoided as the liquid may be

absorbed if the liquid is accumulated near the air vent.

- (i) For the fragility of ITO film, it should avoid to use too tapering pen as the input material.

### Touch Panel Mounting Notes

- (a) If a cushion is used between bezel/housing and film must be choose as free as enough to absorb the expansion and contraction to avoid the distortion of film.
- (b) The cushion must be placed out of the Viewing Area.
- (c) Bezel/Housing edge must be posited between Key Area and Viewing Area. The edge enters the Key Area may cause unexpected input if the gap is too narrow or foreign particles like dusts exist between Bezel/Housing and ITO film.
- (d) Mounting example:

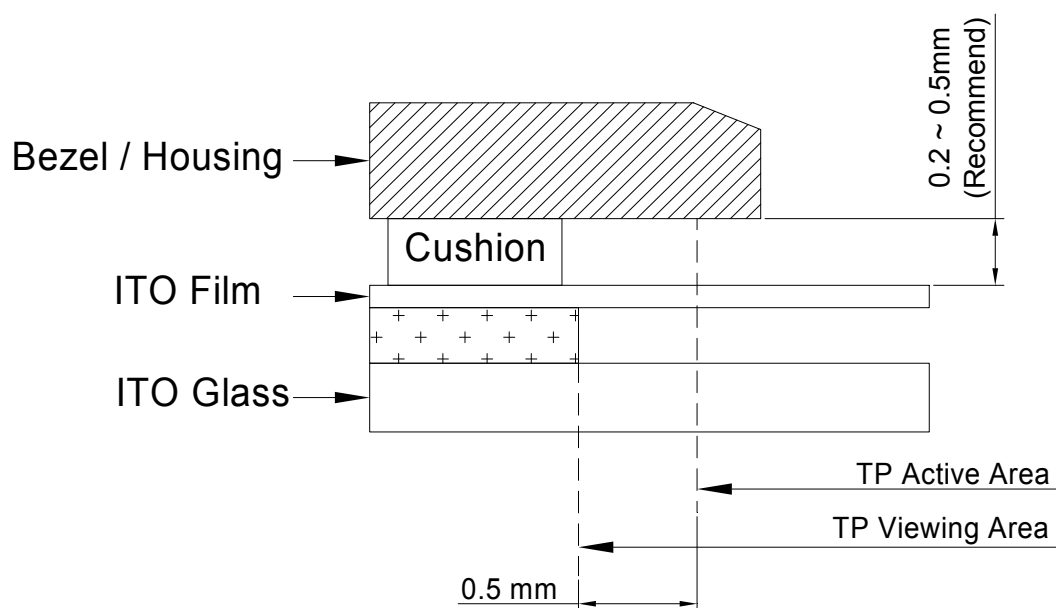

The corner part has conductivity. Do not touch any metal part after mounting.

### Others

- a) If the liquid crystal leaks from the panel, it should be kept away from the eyes or mouth.
- b) For the fragility of polarizer, it is recommended to attach a transparent protective plate over the display surface.
- c) It is recommended to peel off the protection film on the polarizer slowly so that the electrostatic charge can be minimized.