

Doc. Number :

- Tentative Specification
- Preliminary Specification
- Approval Specification

MODEL NO.: G121ICE
SUFFIX: L02

Customer:	
APPROVED BY	SIGNATURE
Name / Title _____	_____
Note	

Please return 1 copy for your confirmation with your signature and comments.	

Approved By	Checked By	Prepared By

CONTENTS

REVISION HISTORY	-----	3
1. GENERAL DESCRIPTION	-----	4
1.1 OVERVIEW		
1.2 GENERAL SPECIFICATIONS		
2. MECHANICAL SPECIFICATIONS	-----	4
3. ABSOLUTE MAXIMUM RATINGS	-----	4
3.1 ABSOLUTE RATINGS OF ENVIRONMENT		
3.2 ELECTRICAL ABSOLUTE RATINGS		
3.2.1 TFT LCD MODULE		
3.2.2 BACKLIGHT UNIT		
4. ELECTRICAL SPECIFICATION	-----	6
4.1 FUNCTION BLOCK DIAGRAM		
4.2 INTERFACE CONNECTIONS		
4.3 ELECTRICAL CHARACTERISTICS		
4.3.1 LCD ELECTRONICS SPECIFICATION		
4.3.2 BACKLIGHT UNIT		
4.4 LVDS INPUT SIGNAL SPECIFICATIONS		
4.4.1 COLOR DATA INPUT ASSIGNMENT		
4.5 DISPLAY TIMING SPECIFICATIONS		
4.6 POWER ON/OFF SEQUENCE		
5. OPTICAL CHARACTERISTICS	-----	17
5.1 TEST CONDITIONS		
5.2 OPTICAL SPECIFICATIONS		
6. Reliability Test Criteria	-----	20
7. MODULE LABEL	-----	21
7.1 MODULE LABEL		
7.2 CARTON LABEL		
8 PRECAUTIONS	-----	23
8.1 ASSEMBLY AND HANDLING PRECAUTIONS		
8.2 STORAGE PRECAUTIONS		
8.3 OPERATION PRECAUTIONS		
8.4 OTHER PRECAUTIONS		
9.MECHANICAL CHARACTERISTICS	-----	24

REVISION HISTORY

Version	Date	Section	Description
Ver. 0.0	Feb.15,2019	All	Tentative Spec was first issued.

1. GENERAL DESCRIPTION

1.1 OVERVIEW

G121ICE-L01 is a 12.1" TFT Liquid Crystal Display module with LED Backlight unit LVDS interface. This module supports 1280 x 800 Wide-XGA MVA mode and can display 262k/16.7M colors . The LED converter for Backlight is built in control board.

1.2 GENERAL SPECIFICATIONS

Item	Specification	Unit	Note
Screen Size	12.1" real diagonal		
Driver Element	a-si TFT active matrix	-	-
Pixel Number	1280 x R.G.B. x 800	pixel	-
Pixel Pitch	0.204(H) x 0.204 (V)	mm	-
Pixel Arrangement	RGB vertical stripe	-	-
Display Colors	262k/16.7M	color	-
Transmissive Mode	Normally Black	-	-
Surface Treatment	AG type, 3H hard coating	-	-
Luminance, White	400	Cd/m2	
Power Consumption	TBD		

2. MECHANICAL SPECIFICATIONS

Item		Min.	Typ.	Max.	Unit	Note
Module Size	Horizontal (H)	277.5	278	278.5	mm	(1)
	Vertical (V)	183.5	184	184.5	mm	
	Thickness (T)	9.5	10	10.5	mm	
Bezel Area	Horizontal	263.82	264.12	264.42	mm	
	Vertical	165.9	166.2	166.5	mm	
Active Area	Horizontal	-	261.12	-	mm	
	Vertical	-	163.2	-	mm	
Weight		-	(485)	(505)	g	

Note (1) Please refer to the attached drawings for more information of front and back outline dimensions.

3. ABSOLUTE MAXIMUM RATINGS

3.1 ABSOLUTE RATINGS OF ENVIRONMENT

Item	Symbol	Value		Unit	Note
		Min.	Max.		
Storage Temperature	TST	(-20)	(70)	°C	(1)
Operating Ambient Temperature	TOP	(-20)	(70)	°C	(1), (2)

Note (1)

(a) 90 %RH Max. (Ta <= 40 °C).

(b) Wet-bulb temperature should be 39 °C Max.

(c) No condensation.

3.2 ELECTRICAL ABSOLUTE RATINGS

3.2.1 TFT LCD MODULE

Item	Symbol	Value		Unit	Note
		Min.	Max.		
Power Supply Voltage	VCCS	-0.3	+4.0	V	(1)
Logic Input Voltage	V _{IN}	-0.3	V _{CC} +0.3	V	

3.2.2 BACKLIGHT UNIT

Item	Value			Unit	Note
	Min	Typ.	Max.		
LED Converter Input voltage	10.8	12.0	13.2	V _{DC}	(1), (2)
LED Converter Input Current	-	(0.5)	-	A _{DC}	

Note (1) Permanent damage to the device may occur if maximum values are exceeded. Function operation should be restricted to the conditions described under Normal Operating Conditions.

Note (2) Specified values are for LED (Refer to Section 3.2 for further information).

4. ELECTRICAL SPECIFICATIONS

4.1 FUNCTION BLOCK DIAGRAM

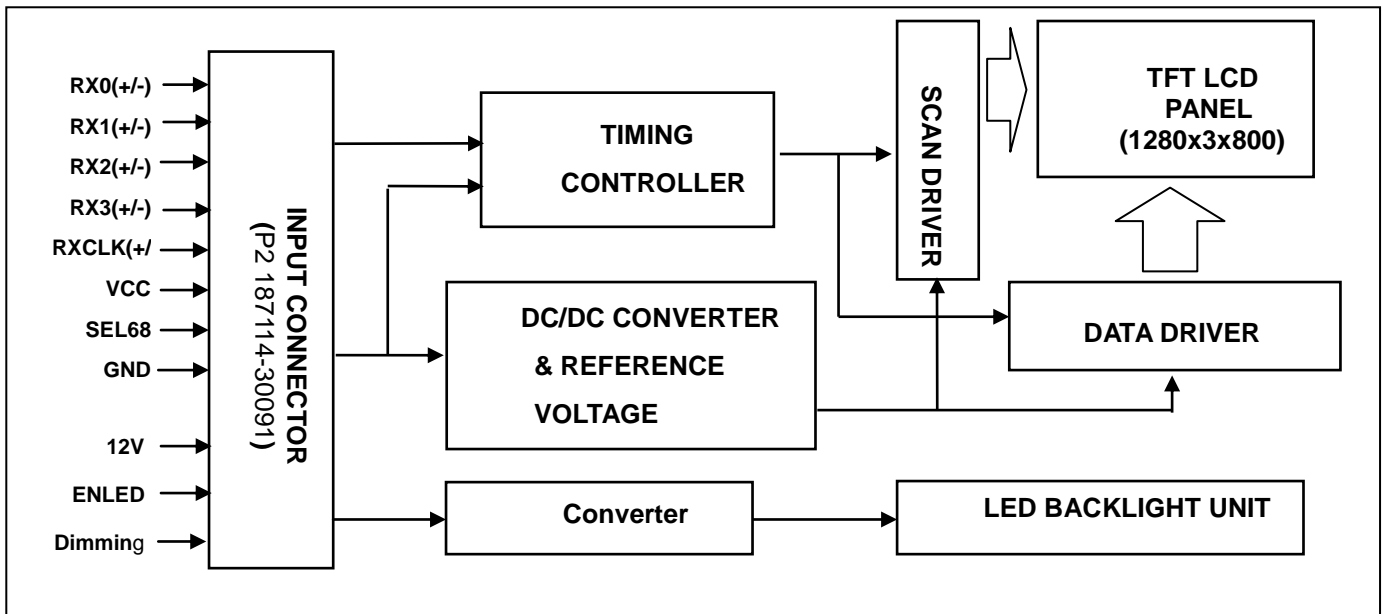

4.2. INTERFACE CONNECTIONS

PIN ASSIGNMENT

Pin No.	Symbol	Description	Note
1	12V	LED power	-
2	12V	LED power	-
3	12V	LED power	-
4	12V	LED power	-
5	ENLED	Enable pin	(3)
6	Dimming	Backlight Adjust	(3)
7	NC	No Connection or Ground	-
8	NC	No Connection or Ground	-
9	VCC	Power supply: +3.3V	
10	VCC	Power supply: +3.3V	-
11	GND	Ground	-
12	GND	Ground	-
13	RX0-	Negative transmission data of pixel 0	-
14	RX0+	Positive transmission data of pixel 0	-
15	GND	Ground	-
16	RX1-	Negative transmission data of pixel 1	-
17	RX1+	Positive transmission data of pixel 1	-
18	GND	Ground	-
19	RX2-	Negative transmission data of pixel 2	-
20	RX2+	Positive transmission data of pixel 2	-

21	GND	Ground	-
22	RXCLK-	Negative of clock	-
23	RXCLK+	Positive of clock	-
24	GND	Ground	-
25	RX3-	Negative transmission data of pixel 3	-
26	RX3+	Positive transmission data of pixel 3	-
27	GND	Ground	-
28	SEL6/8	LVDS 6/8 bit select function control,	(2) (3)
		Low or NC → 6 bit Input Mode	
		High → 8bit Input Mode	
29	GND	Ground	-
30	NC	No Connection or Ground	-

Note (1) Connector Part No.: P2 187114-30091

Note (2) "Low" stands for 0V. "High" stands for 3.3V

Note (3) ENLED(BLON), Dimming(E_PWM), SEL6/8 as shown below :

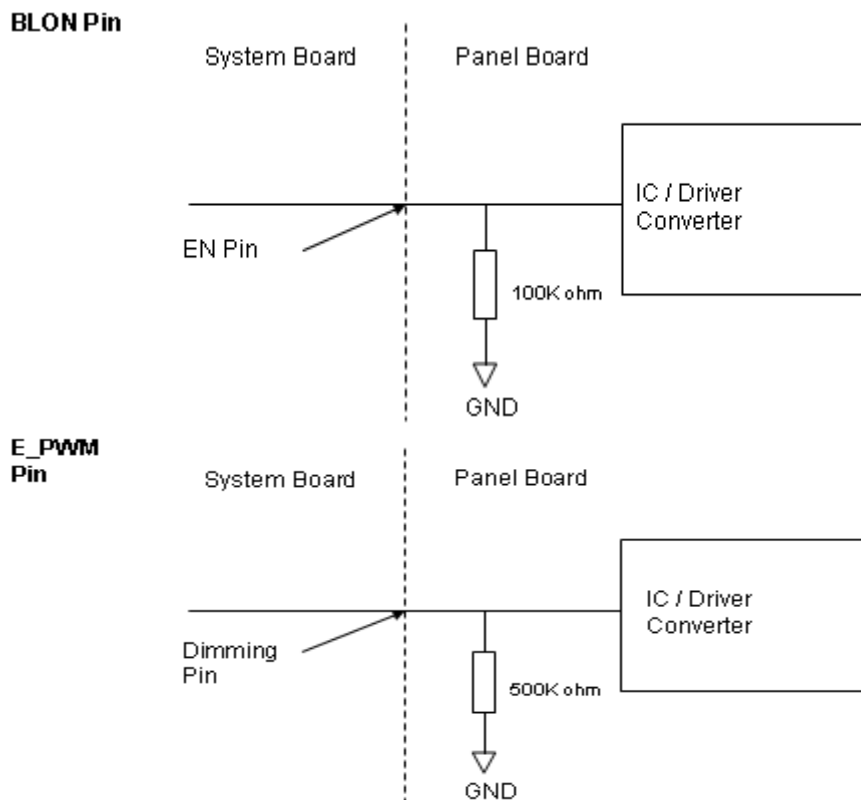

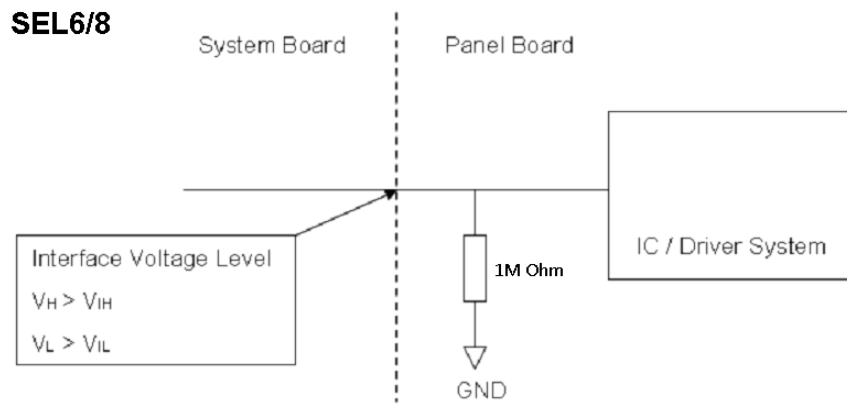

4.3 ELECTRICAL CHARACTERISTICS

4.3.1 LCD ELETRONICS SPECIFICATION

Parameter	Symbol	Value			Unit	Note
		Min.	Typ	Max.		
Power Supply Voltage	V _{CC}	(3.0)	(3.3)	(3.6)	V	-
Permissive Ripple Voltage	V _{RP}	-	(50)	-	mV	-
Rush Current	I _{RUSH}	TBD			A	(2)
Initial Stage Current	I _{IS}	-	-	TBD	A	(2)
Power Supply Current	White	TBD	TBD	TBD	mA	(3)a
	Black	TBD	TBD	TBD	mA	(3)b
LVDS Differential Input High Threshold	V _{TH(LVDS)}	+100	-	-	mV	V _{CM} =1.2V
LVDS Differential Input Low Threshold	V _{TL(LVDS)}	-	-	-100	mV	V _{CM} =1.2V
LVDS Common Mode Voltage	V _{CM}	(1.125)	-	(1.375)	V	
LVDS Differential Input Voltage	V _{ID}	(100)	-	(600)	mV	
Terminating Resistor	R _T	-	100	-	Ohm	

Note (1) The assembly should be always operated within above ranges.

Note (2) Measurement Conditions:

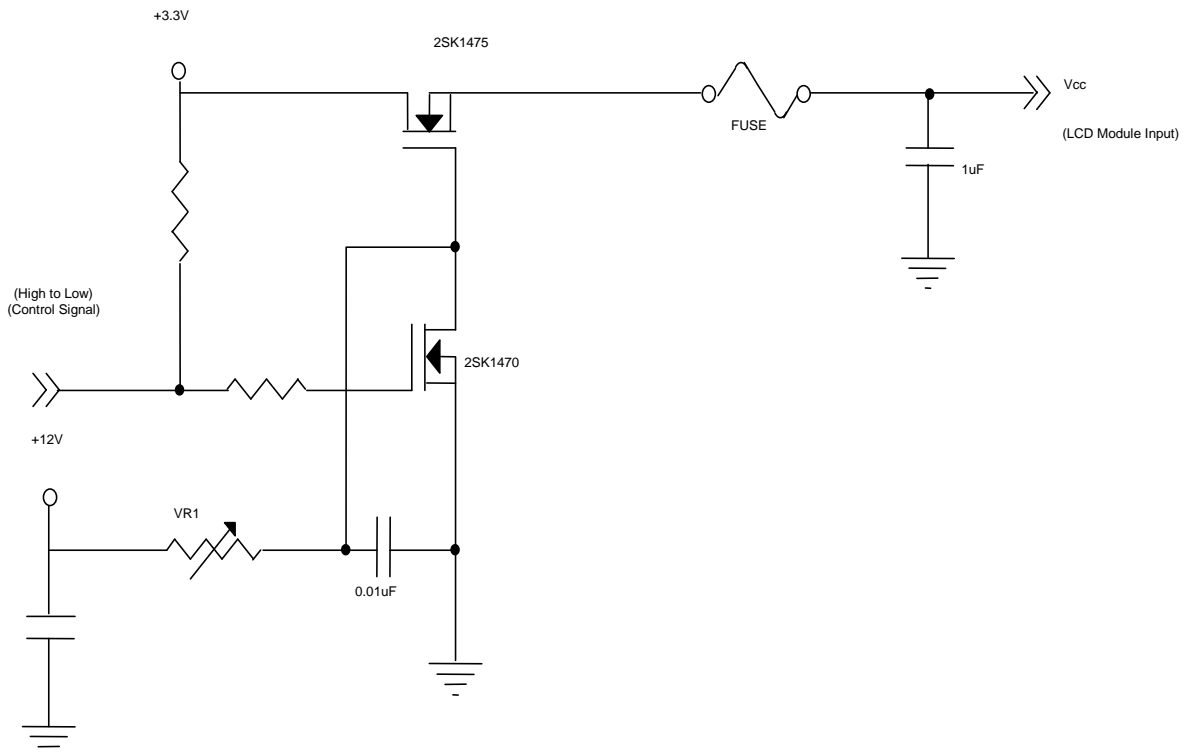

VCC rising time is 470us

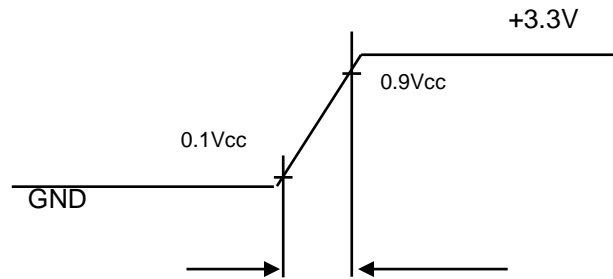

Note (3) The specified power supply current is under the conditions at $V_{cc} = 3.3\text{ V}$, $T_a = 25 \pm 2\text{ }^\circ\text{C}$, $f_v = 60\text{ Hz}$, whereas a power dissipation check pattern below is

a. White Pattern



Active Area

b. Black Pattern

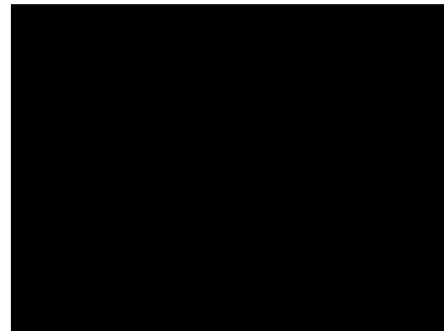

Active Area

c. Vertical Stripe Pattern

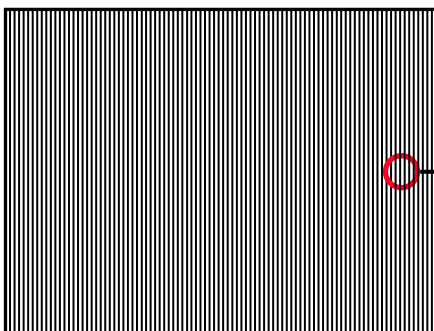

Active Area

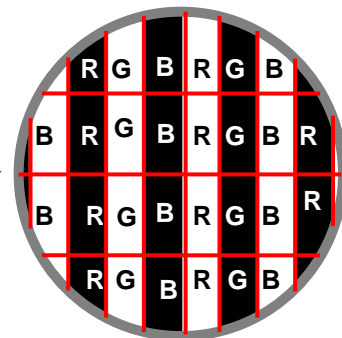

4.3.2 BACKLIGHT UNIT

Parameter	Symbol	Value			Unit	Note	
		Min.	Typ.	Max.			
(LED Converter input voltage)	V_i	10.8	12.0	13.2	V_{DC}	(Duty 100%)	
(LED light bar input current)	I_i	140	160	180	A_{DC}	(Duty 100%)	
LED Lightbar Voltage	V_f	-	(31.9)	-	V_{DC}	$I_f = 80 \text{ mA/EA}$	
LED Current	I_f	-	40	-	mA	Per EA	
Input Power Consumption	P_i	-	(5.6)	-	W	(1)	
EN Control Level	Backlight on	ENLED	2.5	3.3	5.0	V	
	Backlight off		0	---	0.8	V	
PWM Control Level	PWM High Level	Dimming	2.5	---	5.0	V	
	PWM Low Level		0	---	0.15	V	
PWM Control Frequency	f_{PWM}	190	200	20k	Hz	(3)	
PWM Control Duty Ratio		2		100	%	(3), @200Hz	
LED Life Time	L_{BL}	50000	-	-	Hrs	(3)	

Note (1) LED current is measured by utilizing a high frequency current meter as shown below:

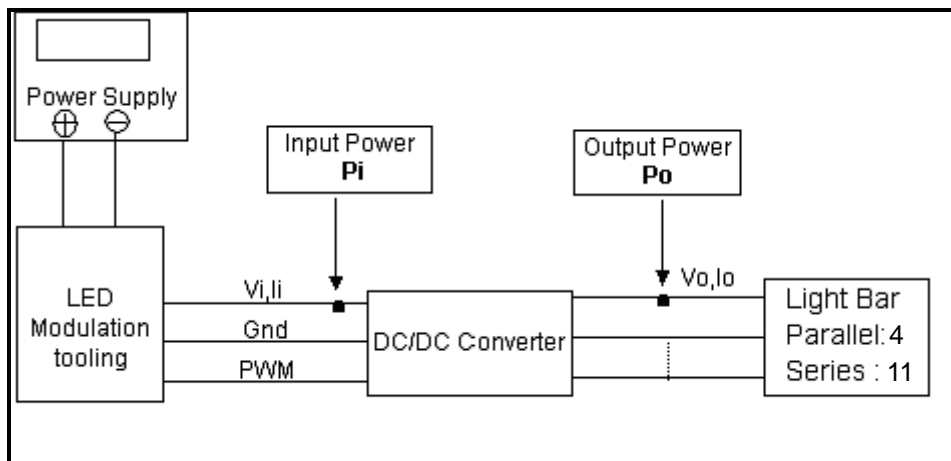

Note (2) The lifetime of LED is estimated data and defined as the time when it continues to operate under the conditions at $T_a = 25 \pm 2 \text{ }^\circ\text{C}$ and Duty 100% until the brightness becomes $\leq 50\%$ of its original value. Operating LED at high temperature condition will reduce life time and lead to color shift.

Note (3) At 200Hz PWM control frequency , duty ratio range is restricted from 2% to 100%, When PWM control frequency is 20kHz, duty ratio range is restricted from 10% to 100%.

4.4 LVDS INPUT SIGNAL SPECIFICATIONS

4.4.1 COLOR DATA INPUT ASSIGNMENT

The brightness of each primary color (red, green and blue) is based on the 6-bit gray scale data input for the color. The higher the binary input, the brighter the color. The table below provides the assignment of color.

Color		Data Signal																	
		Red						Green						Blue					
		R5	R4	R3	R2	R1	R0	G5	G4	G3	G2	G1	G0	B5	B4	B3	B2	B1	B0
Basic Colors	Black	0	0	0	0	0	0	0	0	0	0	0	0	0	0	0	0	0	0
	Red	1	1	1	1	1	1	0	0	0	0	0	0	0	0	0	0	0	0
	Green	0	0	0	0	0	0	1	1	1	1	1	1	0	0	0	0	0	0
	Blue	0	0	0	0	0	0	0	0	0	0	0	0	1	1	1	1	1	1
	Cyan	0	0	0	0	0	0	1	1	1	1	1	1	1	1	1	1	1	1
	Magenta	1	1	1	1	1	1	0	0	0	0	0	0	1	1	1	1	1	1
	Yellow	1	1	1	1	1	1	1	1	1	1	1	1	0	0	0	0	0	0
	White	1	1	1	1	1	1	1	1	1	1	1	1	1	1	1	1	1	1
Gray Scale Of Red	Red(0)/Dark	0	0	0	0	0	0	0	0	0	0	0	0	0	0	0	0	0	0
	Red(1)	0	0	0	0	0	1	0	0	0	0	0	0	0	0	0	0	0	0
	Red(2)	0	0	0	0	1	0	0	0	0	0	0	0	0	0	0	0	0	0
	:	:	:	:	:	:	:	:	:	:	:	:	:	:	:	:	:	:	:
	:	:	:	:	:	:	:	:	:	:	:	:	:	:	:	:	:	:	:
	Red(61)	1	1	1	1	0	1	0	0	0	0	0	0	0	0	0	0	0	0
	Red(62)	1	1	1	1	1	0	0	0	0	0	0	0	0	0	0	0	0	0
	Red(63)	1	1	1	1	1	1	0	0	0	0	0	0	0	0	0	0	0	0
Gray Scale Of Green	Green(0)/Dark	0	0	0	0	0	0	0	0	0	0	0	0	0	0	0	0	0	0
	Green(1)	0	0	0	0	0	0	0	0	0	0	0	1	0	0	0	0	0	0
	Green(2)	0	0	0	0	0	0	0	0	0	0	1	0	0	0	0	0	0	0
	:	:	:	:	:	:	:	:	:	:	:	:	:	:	:	:	:	:	:
	:	:	:	:	:	:	:	:	:	:	:	:	:	:	:	:	:	:	:
	Green(61)	0	0	0	0	0	0	1	1	1	1	0	1	0	0	0	0	0	0
	Green(62)	0	0	0	0	0	0	1	1	1	1	1	0	0	0	0	0	0	0
	Green(63)	0	0	0	0	0	0	1	1	1	1	1	1	0	0	0	0	0	0
Gray Scale Of Blue	Blue(0)/Dark	0	0	0	0	0	0	0	0	0	0	0	0	0	0	0	0	0	0
	Blue(1)	0	0	0	0	0	0	0	0	0	0	0	0	0	0	0	0	0	1
	Blue(2)	0	0	0	0	0	0	0	0	0	0	0	0	0	0	0	0	1	0
	:	:	:	:	:	:	:	:	:	:	:	:	:	:	:	:	:	:	:
	:	:	:	:	:	:	:	:	:	:	:	:	:	:	:	:	:	:	:
	Blue(61)	0	0	0	0	0	0	0	0	0	0	0	0	1	1	1	1	0	1
	Blue(62)	0	0	0	0	0	0	0	0	0	0	0	0	1	1	1	1	1	0
	Blue(63)	0	0	0	0	0	0	0	0	0	0	0	0	1	1	1	1	1	1

Note (1) 0: Low Level Voltage, 1: High Level Voltage

The brightness of each primary color (red, green and blue) is based on the 8-bit gray scale data input for the color. The higher the binary input, the brighter the color. The table below provides the assignment of color.

Color		Data Signal																						
		Red								Green								Blue						
		R7	R6	R5	R4	R3	R2	R1	R0	G7	G6	G5	G4	G3	G2	G1	G0	B7	B6	B5	B4	B3	B2	B1
Basic Colors	Black	0	0	0	0	0	0	0	0	0	0	0	0	0	0	0	0	0	0	0	0	0	0	0
	Red	1	1	1	1	1	1	1	1	0	0	0	0	0	0	0	0	0	0	0	0	0	0	0
	Green	0	0	0	0	0	0	0	0	1	1	1	1	1	1	1	1	0	0	0	0	0	0	0
	Blue	0	0	0	0	0	0	0	0	0	0	0	0	0	0	0	0	1	1	1	1	1	1	1
	Cyan	0	0	0	0	0	0	0	0	1	1	1	1	1	1	1	1	1	1	1	1	1	1	1
	Magenta	1	1	1	1	1	1	1	1	0	0	0	0	0	0	0	0	1	1	1	1	1	1	1
	Yellow	1	1	1	1	1	1	1	1	1	1	1	1	1	1	1	1	0	0	0	0	0	0	0
	White	1	1	1	1	1	1	1	1	1	1	1	1	1	1	1	1	1	1	1	1	1	1	1
Gray Scale Of Red	Red(0) / Dark	0	0	0	0	0	0	0	0	0	0	0	0	0	0	0	0	0	0	0	0	0	0	
	Red(1)	0	0	0	0	0	0	0	1	0	0	0	0	0	0	0	0	0	0	0	0	0	0	
	Red(2)	0	0	0	0	0	0	1	0	0	0	0	0	0	0	0	0	0	0	0	0	0	0	
	:	:	:	:	:	:	:	:	:	:	:	:	:	:	:	:	:	:	:	:	:	:	:	
	:	:	:	:	:	:	:	:	:	:	:	:	:	:	:	:	:	:	:	:	:	:	:	
	Red(253)	1	1	1	1	1	1	0	1	0	0	0	0	0	0	0	0	0	0	0	0	0	0	
	Red(254)	1	1	1	1	1	1	1	0	0	0	0	0	0	0	0	0	0	0	0	0	0	0	
	Red(255)	1	1	1	1	1	1	1	1	0	0	0	0	0	0	0	0	0	0	0	0	0	0	
Gray Scale Of Green	Green(0) / Dark	0	0	0	0	0	0	0	0	0	0	0	0	0	0	0	0	0	0	0	0	0	0	
	Green(1)	0	0	0	0	0	0	0	0	0	0	0	0	0	0	0	1	0	0	0	0	0	0	
	Green(2)	0	0	0	0	0	0	0	0	0	0	0	0	0	0	1	0	0	0	0	0	0	0	
	:	:	:	:	:	:	:	:	:	:	:	:	:	:	:	:	:	:	:	:	:	:	:	
	:	:	:	:	:	:	:	:	:	:	:	:	:	:	:	:	:	:	:	:	:	:	:	
	Green(253)	0	0	0	0	0	0	0	0	1	1	1	1	1	1	0	1	0	0	0	0	0	0	
	Green(254)	0	0	0	0	0	0	0	0	1	1	1	1	1	1	1	0	0	0	0	0	0	0	
	Green(255)	0	0	0	0	0	0	0	0	1	1	1	1	1	1	1	1	0	0	0	0	0	0	
Gray Scale Of Blue	Blue(0) / Dark	0	0	0	0	0	0	0	0	0	0	0	0	0	0	0	0	0	0	0	0	0	0	
	Blue(1)	0	0	0	0	0	0	0	0	0	0	0	0	0	0	0	0	0	0	0	0	0	1	
	Blue(2)	0	0	0	0	0	0	0	0	0	0	0	0	0	0	0	0	0	0	0	0	0	1	
	:	:	:	:	:	:	:	:	:	:	:	:	:	:	:	:	:	:	:	:	:	:	:	
	:	:	:	:	:	:	:	:	:	:	:	:	:	:	:	:	:	:	:	:	:	:	:	
	Blue(253)	0	0	0	0	0	0	0	0	0	0	0	0	0	0	0	1	1	1	1	1	1	0	
	Blue(254)	0	0	0	0	0	0	0	0	0	0	0	0	0	0	0	1	1	1	1	1	1	1	
	Blue(255)	0	0	0	0	0	0	0	0	0	0	0	0	0	0	0	1	1	1	1	1	1	1	

Note: 0: Low Level Voltage, 1: High Level Voltage

4.5 DISPLAY TIMING SPECIFICATIONS

The input signal timing specifications are shown as the following table and timing diagram.

Signal	Item	Symbol	Min.	Typ.	Max.	Unit	Note
DCLK	Frequency	1/Tc	(66.1)	(71)	(89.7)	MHz	-
DE	Vertical Total Time	Tv	(810)	(823)	(890)	Th	(3)
	Vertical Addressing Time	Tvd	(800)	(800)	(800)	Th	-
	Horizontal Total Time	Th	(1360)	(1440)	(1680)	Tc	-
	Horizontal Addressing Time	Thd	(1280)	(1280)	(1280)	Tc	-

Note: (1) Because this module is operated by DE only mode, Hsync and Vsync input signals are ignored.

(2) Frame rate is 60Hz

(3) The Tv must be integer, otherwise, this module would operate abnormally.

INPUT SIGNAL TIMING DIAGRAM

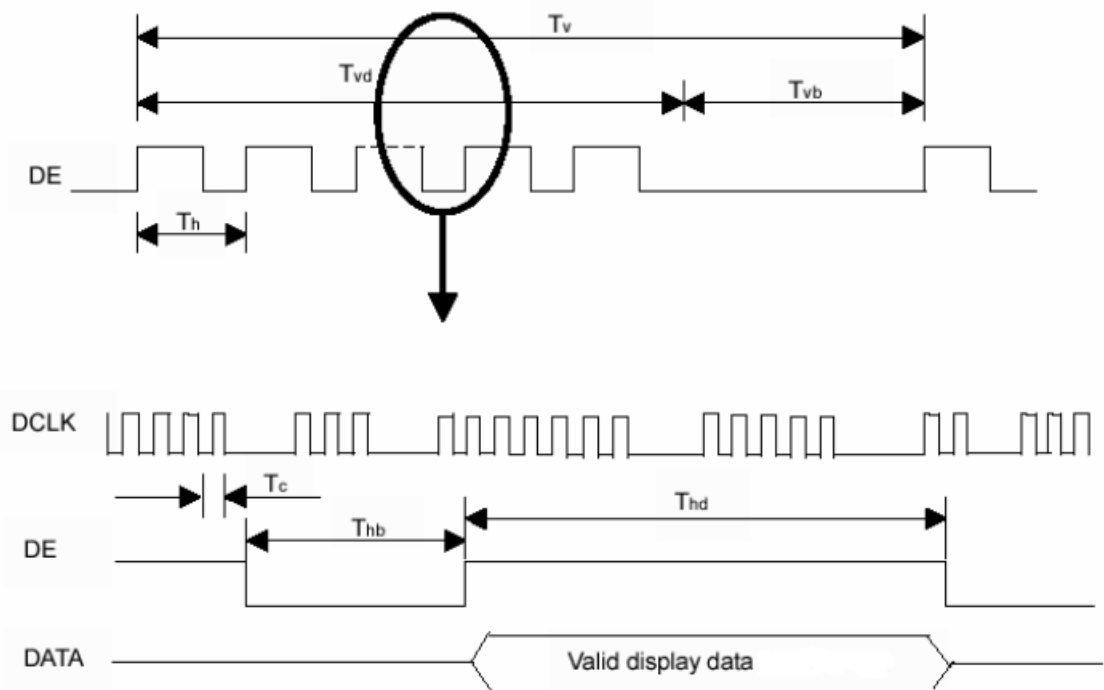

4.6 POWER ON/OFF SEQUENCE

To prevent a latch-up or DC operation of LCD assembly, the power on/off sequence should be as the diagram below.

Power ON/OFF sequence

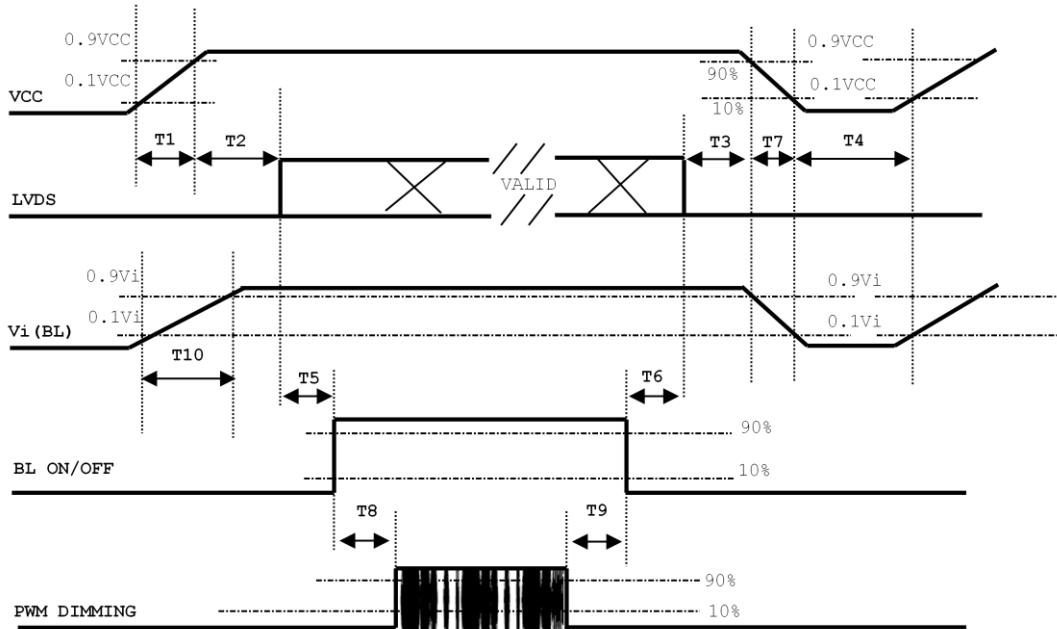

Note (1) Please avoid floating state of interface signal at invalid period.

Note (2) When the interface signal is invalid, be sure to pull down the power supply of LCD VCC to 0 V.

Note (3) The Backlight converter power must be turned on after the power supply for the logic and the interface signal is valid. The Backlight converter power must be turned off before the power supply for the logic and the interface signal is invalid.

Parameter	Value			Units
	Min	Typ	Max	
T1	0.5	---	10	ms
T2	0	---	50	ms
T3	0	---	50	ms
T4	500	---	---	ms
T5	450	---	---	ms
T6	200	---	---	ms
T7	10	---	100	ms
T8	10	---	---	ms
T9	10	---	---	ms
T10	20	---	50	ms

The Input Data Format

SEL 6/8="Low" or "NC" for 6 Bits LVDS

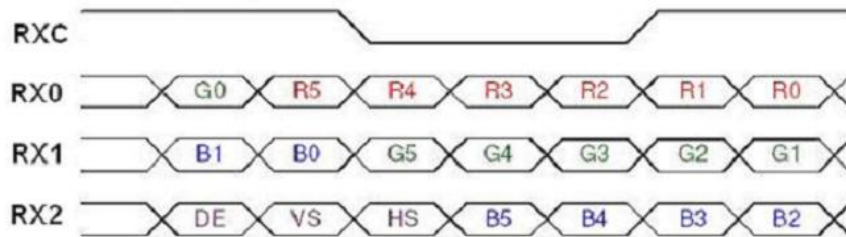

SEL 6/8="High" for 8 Bits LVDS

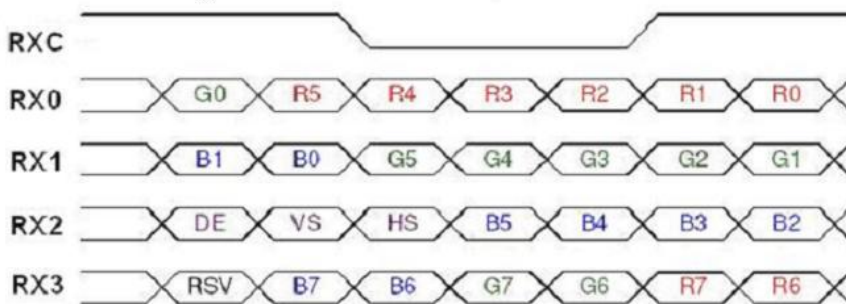

Note (1) R/G/B data 7: MSB, R/G/B data 0: LSB

Note (2) Please follow PSWG

Signal Name	Description	Remark
R7	Red Data 7 (MSB)	Red-pixel Data Each red pixel's brightness data consists of these 8 bits pixel data.
R6	Red Data 6	
R5	Red Data 5	
R4	Red Data 4	
R3	Red Data 3	
R2	Red Data 2	
R1	Red Data 1	
R0	Red Data 0 (LSB)	
G7	Green Data 7 (MSB)	Green-pixel Data Each green pixel's brightness data consists of these 8 bits pixel data.
G6	GreenData 6	
G5	GreenData 5	
G4	GreenData 4	
G3	GreenData 3	
G2	GreenData 2	
G1	GreenData 1	
G0	GreenData 0 (LSB)	
B7	Blue Data 7 (MSB)	Blue-pixel Data Each blue pixel's brightness data consists of these 8 bits pixel data.
B6	Blue Data 6	
B5	Blue Data 5	
B4	Blue Data 4	
B3	Blue Data 3	
B2	Blue Data 2	
B1	Blue Data 1	
B0	Blue Data 0 (LSB)	
RXCLKIN+ RXCLKIN-	LVDS Clock Input	
DE	Display Enable	
VS	Vertical Sync	
HS	Horizontal Sync	

5. OPTICAL CHARACTERISTICS

5.1 TEST CONDITIONS

Item	Symbol	Value	Unit
Ambient Temperature	Ta	25±2	°C
Ambient Humidity	Ha	50±10	%RH
Supply Voltage	V _{CC}	3.3	V
Convertor Voltage	According to typical value in "3. ELECTRICAL CHARACTERISTICS"		
Convertor Duty			

The relative measurement methods of optical characteristics are shown in 5.2. and all items are measured at the center point of screen except white variation. The following items should be measured under the test conditions described in 5.1 and stable environment shown in Note (5).

5.2 OPTICAL SPECIFICATIONS

The relative measurement methods of optical characteristics are shown in 5.2. The following items should be measured under the test conditions described in 5.1 and stable environment shown in Note (5).

Item	Symbol	Condition	Min.	Typ.	Max.	Unit	Note	
Contrast Ratio	CR	$\theta_x=0^\circ, \theta_y=0^\circ$ Viewing Normal Angle		(1000)	-	-	(2), (5)	
Response Time	T _R		-	(15)		ms	(3)	
	T _F		-	(12)		ms		
Luminance of White (5P)	L _{Ave}		(320)	(400)	-	cd/m ²	(4), (5)	
White Variation	δW		-	(1.25)		-	(5), (6)	
Color Chromaticity	Red		R _x	Typ. 0.05	(0.592)	Typ. + 0.05	-	(1), (5)
			R _y		(0.355)		-	
	Green		G _x		(0.350)		-	
			G _y		(0.575)		-	
	Blue		B _x		(0.155)		-	
		B _y	(0.111)		-			
	White	W _x	(0.313)		-			
		W _y	(0.329)		-			
Viewing Angle	Horizontal	θ_{x+}	CR≥10	(88)	-	Deg	(1), (5)	
		θ_{x-}		(88)	-			
	Vertical	θ_{y+}		(88)	-			
		θ_{y-}		(88)	-			

Note (1) Definition of Viewing Angle (θ_x, θ_y):

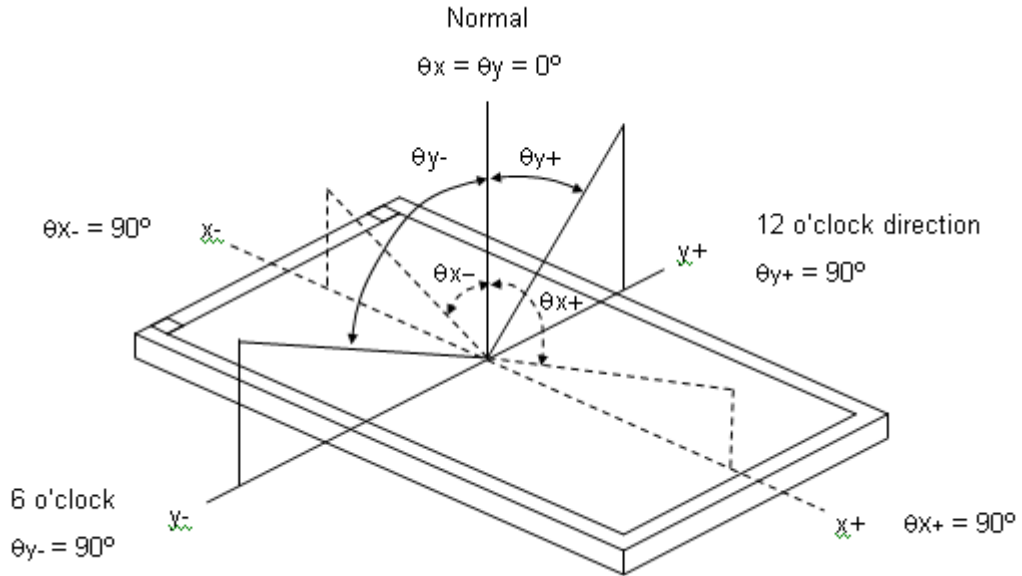

Note (2) Definition of Contrast Ratio (CR):

The contrast ratio can be calculated by the following expression.

$$\text{Contrast Ratio (CR)} = L_{255} / L_0$$

L63: Luminance of gray level 255

L 0: Luminance of gray level 0

$$\text{CR} = \text{CR} (5)$$

CR (X) is corresponding to the Contrast Ratio of the point X at Figure in Note (6).

Note (3) Definition of Response Time (T_R, T_F):

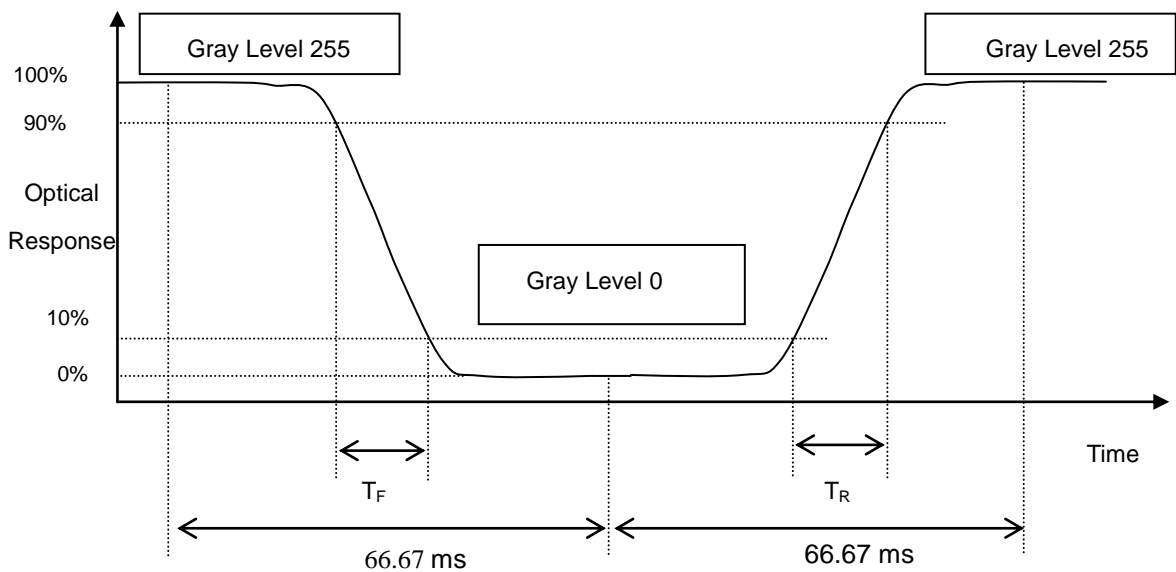

Note (4) Definition of Average Luminance of White (L_{AVE}):

Measure the luminance of gray level 255 at 5 points

$$L_{AVE} = [L(1) + L(2) + L(3) + L(4) + L(5)] / 5$$

$L(x)$ is corresponding to the luminance of the point X at Figure in Note (6).

Note (5) Measurement Setup:

The LCD module should be stabilized at given temperature for 20 minutes to avoid abrupt temperature change during measuring. In order to stabilize the luminance, the measurement should be executed after lighting Backlight for 20 minutes in a windless room.

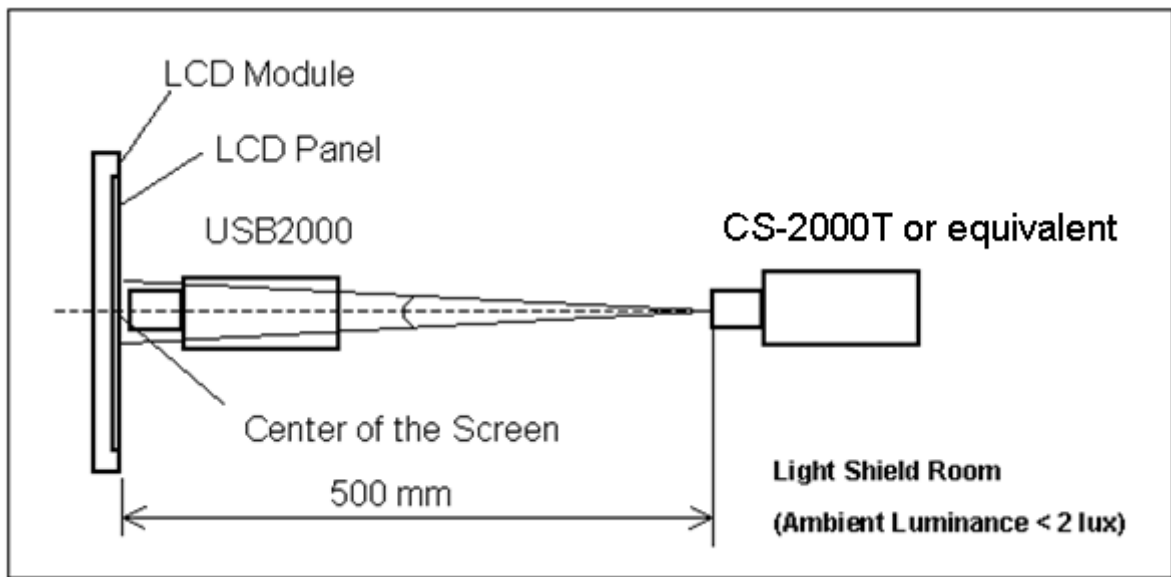

Note (6) Definition of White Variation (δW):

Measure the luminance of gray level 255 at 5 points

$$\delta W = \frac{\text{Maximum } [L(1), L(2), L(3), L(4), L(5)]}{\text{Minimum } [L(1), L(2), L(3), L(4), L(5)]}$$

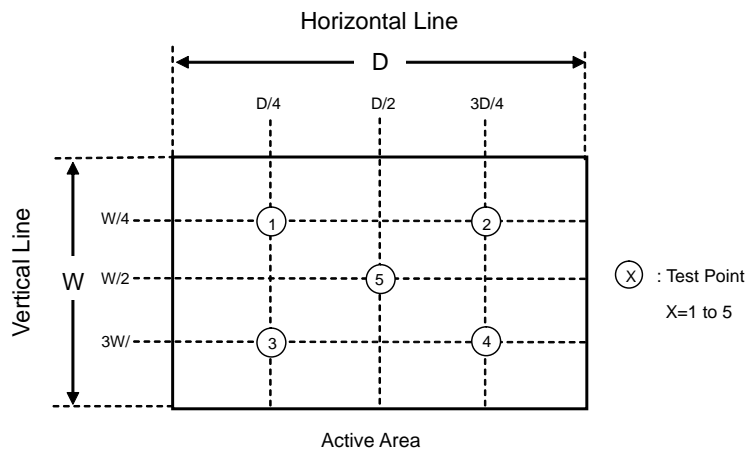

6. Reliability Test Criteria

Test Item	Test Condition	Note
High Temperature Storage Test	70°C, 240 hours	(1),(2) (4),(5)
Low Temperature Storage Test	-20°C, 240 hours	
Thermal Shock Storage Test	-20°C, 0.5hour \longleftrightarrow 70°C, 0.5hour; 100cycles, 1hour/cycle	
High Temperature Operation Test	70°C, 240 hours	
Low Temperature Operation Test	-20°C, 240 hours	
High Temperature & High Humidity Operation Test	60°C, 90%RH, 240hours	(1),(2) (4),(6)
Shock (Non-Operating)	50G, 11ms, half sine wave, 1 time for $\pm X$, $\pm Y$, $\pm Z$ direction	(2), (3)
Vibration (Non-Operating)	1.5G, 10 ~ 300 Hz sine wave, 10 min/cycle, 3 cycles each X, Y, Z direction	(2), (3)

Note (1) There should be no condensation on the surface of panel during test.

Note (2) Temperature of panel display surface area should be 73°C Max.

Note (3) At testing Vibration and Shock, the fixture in holding the module has to be hard and rigid enough so that the module would not be twisted or bent by the fixture.

Note (4) In the standard conditions, there is no function failure issue occurred. All the cosmetic specification

is judged before reliability test.

Note (5) Before cosmetic and function test, the product must have enough recovery time, at least 2 hours at room temperature.

Note (6) Before cosmetic and function test, the product must have enough recovery time, at least 24 hours at room temperature.

7. MODULE LABEL

7.1 MODULE LABEL

The barcode nameplate is pasted on each module as illustration, and its definitions are as following explanation.

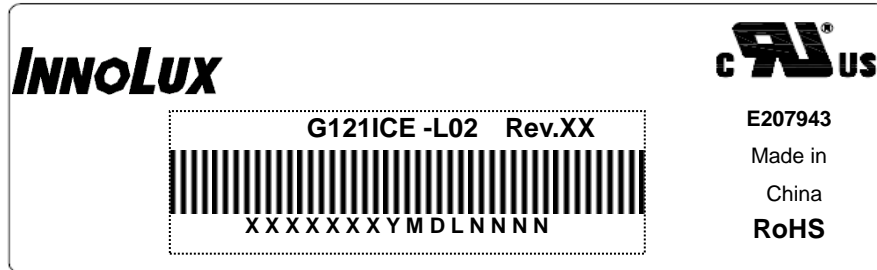

(a) Model Name: G121ICE-L02

(b) Revision: Rev. XX, for example: A0, A1... B1, B2... or C1, C2...etc.

(c) INX barcode definition:

Serial ID: XX-XX-X-XX-YMD-L-NNNN

Code	Meaning	Description
XX	INX internal use	-
XX	Revision	Cover all the change
X	INX internal use	-
XX	INX internal use	-
YMD	Year, month, day	Year: 0~9, 2001=1, 2002=2, 2003=3...2010=0, 2011=1, 2012=2... Month: 1~12=1, 2, 3, ~, 9, A, B, C Day: 1~31=1, 2, 3, ~, 9, A, B, C, ~, W, X, Y, exclude I, O, and U.
L	Product line #	Line 1=1, Line 2=2, Line 3=3, ...
NNNN	Serial number	Manufacturing sequence of product

7.2 CARTON LABEL

INNOLUX

PO.NO. _____

Part ID. _____

Model Name **G121ICE -L02 Rev.XX**

Carton ID. Quantities xx

XXXXXXXXXXXXXXXXXX

Made in Taiwan

GP
RoHS

- (a) P/N: Internal control
- (b) Model Name: G121ICE-L02
- (c) Production year and month: shown at left down corner
- (d) Production location: Made In XXXX. XXXX stands for production location.

8. PRECAUTIONS

8.1 ASSEMBLY AND HANDLING PRECAUTIONS

- (1) The module should be assembled into the system firmly by using every mounting hole. Be careful not to twist or bend the module.
- (2) While assembling or installing modules, it can only be in the clean area. The dust and oil may cause electrical short or damage the polarizer.
- (3) Use fingerstalls or soft gloves in order to keep display clean during the incoming inspection and assembly process.
- (4) Do not press or scratch the surface harder than a HB pencil lead on the panel because the polarizer is very soft and easily scratched.
- (5) If the surface of the polarizer is dirty, please clean it by some absorbent cotton or soft cloth. Do not use Ketone type materials (ex. Acetone), Ethyl alcohol, Toluene, Ethyl acid or Methyl chloride. It might permanently damage the polarizer due to chemical reaction.
- (6) Wipe off water droplets or oil immediately. Staining and discoloration may occur if they left on panel for a long time.
- (7) If the liquid crystal material leaks from the panel, it should be kept away from the eyes or mouth. In case of contacting with hands, legs or clothes, it must be washed away thoroughly with soap.
- (8) Protect the module from static electricity, it may cause damage to the C-MOS Gate Array IC.
- (9) Do not disassemble the module.
- (10) Do not pull or fold the lamp wire.
- (11) Pins of I/F connector should not be touched directly with bare hands.

8.2 STORAGE PRECAUTIONS

- (1) High temperature or humidity may reduce the performance of module. Please store LCD module within the specified storage conditions.
- (2) It is dangerous that moisture come into or contacted the LCD module, because the moisture may damage LCD module when it is operating.
- (3) It may reduce the display quality if the ambient temperature is lower than 10 °C. For example, the response time will become slowly, and the starting voltage of lamp will be higher than the room temperature.

8.3 OPERATION PRECAUTIONS

- (1) Do not pull the I/F connector in or out while the module is operating.
- (2) Always follow the correct power on/off sequence when LCD module is connecting and operating. This can prevent the CMOS LSI chips from damage during latch-up.
- (3) The startup voltage of Backlight is approximately 1000 Volts. It may cause electrical shock while assembling with converter. Do not disassemble the module or insert anything into the Backlight unit.

8.4 OTHER PRECAUTIONS

- (1) When fixed patterns are displayed for a long time, remnant image is likely to occur.

9. MECHANICAL CHARACTERISTICS

