

6W,Ultra wide input isolated & regulated dual/single output , DIP package, DC/DC converter

FEATURES

- Wide input voltage range (4:1)
- High efficiency up to 88%
- No-load power consumption as low as 0.12W
- Isolation voltage :3K VDC
- Operating temperature range: -40°C to +85°C
- Input under-voltage protection, output short circuit , over-current, over-voltage protection
- Meet CISPR32/EN55032 CLASS A, without external components
- International standard pin-out
- IEC60950,UL60950,EN60950 approval

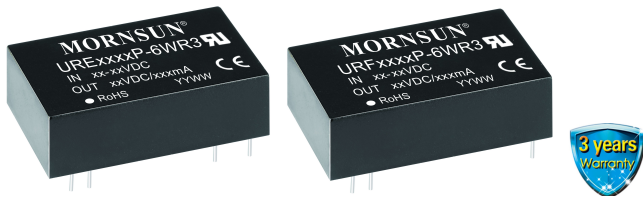

UL **CB** **CE** Patent Protection **RoHS**

URE_P-6WR3 & URF_P-6WR3 series are isolated 6W DC-DC converters with 4:1 input voltage. They feature efficiency up to 88%, 3000VDC isolation voltage, operating temperature of -40°C to +85°C, isolation voltage of 3000VDC, output over-voltage protection and output short circuit protection with the bare component in compliance with CISPR32/EN55032 CLASS A; these products are widely used in fields such as industrial control, electric power, instruments and communication.

Selection Guide

Certification	Part No.	Input Voltage (VDC)		Output		Efficiency (%Min./Typ.) ^② @ Full Load	Max. Capacitive Load ^③ (μF)
		Nominal (Range)	Max. ^①	Output Voltage (VDC)	Output Current (mA) (Max./Min.)		
UL/CE/CB	URE2405P-6WR3	24 (9-36)	40	±5	±600/0	78/80	680
	URE2412P-6WR3			±12	±250/0	82/84	330
	URE2415P-6WR3			±15	±200/0	83/85	220
	URF2403P-6WR3			3.3	1500/0	77/79	2200
	URF2405P-6WR3			5	1200/0	80/82	2200
	URF2409P-6WR3			9	667/0	83/85	1000
	URF2412P-6WR3			12	500/0	84/86	680
	URF2415P-6WR3			15	400/0	86/88	680
	URF2424P-6WR3			24	250/0	85/87	680
	URF4803P-6WR3			48 (18-75)	80	3.3	1500/0
	URF4805P-6WR3	5	1200/0			81/83	2200
	URF4812P-6WR3	12	500/0			85/87	680
	URF4815P-6WR3	15	400/0			86/88	680
	URF4824P-6WR3	24	250/0			85/87	680

Notes:

- ① The input voltage should not exceed the maximum rating, or it might cause unrecoverable damages;
- ② Efficiency is measured in nominal input voltage and rated output load;
- ③ The capacitive loads of positive and negative outputs are identical.

Input Specifications

Item	Operating Conditions		Min.	Typ.	Max.	Unit
Input Current (full load / no-load)	24VDC Input	3.3V output	--	261/5	268/8	mA
		Other output	--	297/5	320/8	
	48VDC Input	3.3V output	--	131/4	134/7	
		Other output	--	146/4	154/7	
Reflected Ripple Current	24VDC Input		--	20	--	mA
	48VDC Input		--	20	--	
Input Impulse Voltage (1sec. max.)	24VDC Input		-0.7	--	50	VDC
	48VDC Input		-0.7	--	100	
Starting Voltage	24VDC Input		--	--	9	VDC
	48VDC Input		--	--	18	
Input Under-voltage Protection	24VDC Input		5.5	6.5	--	VDC
	48VDC Input		12	15.5	--	

Starting Time	Nominal input& constant resistance load	--	10	--	ms
Input Filter		PI filter			
Hot Plug		Unavailable			

Output Specifications

Item	Operating Conditions	Min.	Typ.	Max.	Unit	
Output Voltage Accuracy	5%-100% load	--	±1	±3	%	
	0%-5% load	Single output	--	±1		±3
		Dual output	--	±2		±5
Balance of Output Voltage	Dual output, balanced load	--	±0.5	±1.5		
Line Regulation	Full load, the input voltage is from low voltage to high voltage	Positive output	--	±0.2		±0.5
		Negative output	--	±0.5		±1
Load Regulation ^①	5%-100% load	Positive output	--	±0.5		±1
		Negative output	--	±0.5		±1.5
Cross Regulation	Dual output, main circuit with 50% load, auxiliary circuit with 10%-100% load	--	--	±5		
Transient Recovery Time	25% load step change	--	300	500		μs
Transient Response Deviation		--	±3	±5	%	
Temperature Drift Coefficient	Full load	--	--	±0.03	%/°C	
Ripple&Noise ^②	20MHz bandwidth, 5%-100% load	--	85	120	mV p-p	
Over-voltage Protection	Input voltage range	110	--	160	%Vo	
Over-current Protection	Input voltage range	24V output	110	220	290	%Io
		Others	110	140	190	
Short circuit Protection	Input voltage range	Continuous, self-recovery				

Note:①When testing from 0% to 100% load working conditions, load regulation index of ±5%;
②0%-5% load ripple&Noise is no more than 5%Vo. Ripple and noise are measured by "parallel cable" method, please see DC-DC Converter Application Notes for specific operation.

General Specifications

Item	Operating Conditions	Min.	Typ.	Max.	Unit
Isolation Voltage	Input-output, with the test time of 1 minute and the leak current lower than 1mA	3000	--	--	VDC
Isolation Resistance	Input-output, insulation voltage 500VDC	1000	--	--	MΩ
Isolation Capacitance	Input-output, 100KHz/0.1V	--	1000	--	pF
Operating Temperature	Derating if the temperature is ≥71 °C(see Fig. 1)	-40	--	85	°C
Storage Temperature		-55	--	125	
Storage Humidity	Non-condensing	5	--	95	%RH
Pin Welding Resistance Temperature	Welding spot is 1.5mm away from the casing, 10 seconds	--	--	300	°C
Vibration		10-55Hz, 10G, 30 Min. along X, Y and Z			
Switching Frequency	PWM mode	--	300	--	KHz
MTBF	MIL-HDBK-217F@25°C	1000	--	--	K hours

Note:* This series of products using the technique of reducing frequency. The switching frequency is test at full load; when the load is below 50%, the switching frequency decreases with decreasing load.

Physical Specifications

Casing Material	Black flame-retardant heat-proof plastic (UL94 V-0)
Package Dimensions	31.60*20.30*10.20 mm
Weight	13.00g(Typ.)
Cooling method	Free air convection

EMC Specifications

EMI	CE	CISPR32/EN55032 CLASS A (Bare component)/ CLASS B (see Fig.3-② for recommended circuit)	
	RE	CISPR32/EN55032 CLASS A (Bare component)/ CLASS B (see Fig.3-② for recommended circuit)	
EMS	ESD	IEC/EN61000-4-2	Contact ±4KV perf. Criteria B
	RS	IEC/EN61000-4-3	10V/m perf. Criteria A
	EFT	IEC/EN61000-4-4	±2KV (see Fig.3-① for recommended circuit) perf. Criteria B
	Surge	IEC/EN61000-4-5	±2KV (see Fig.3-① for recommended circuit) perf. Criteria B
	CS	IEC/EN61000-4-6	3 Vr.m.s perf. Criteria A
	Immunities of voltage dip, drop and short interruption	IEC/EN61000-4-29	0-70% perf. Criteria B

Product Characteristic Curve

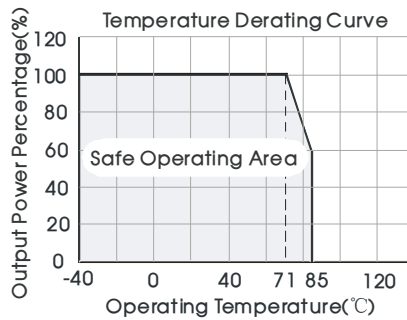
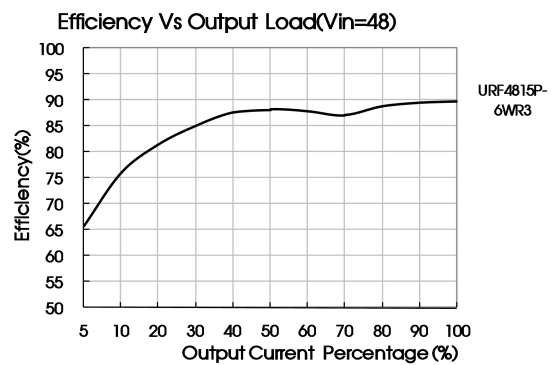
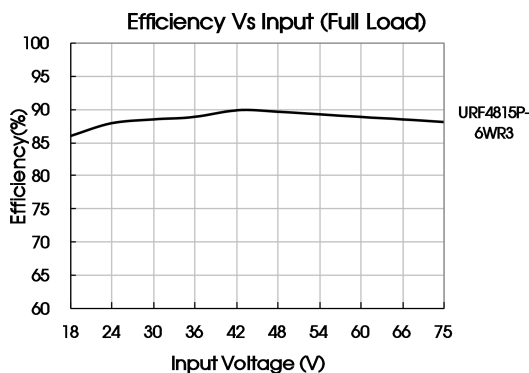
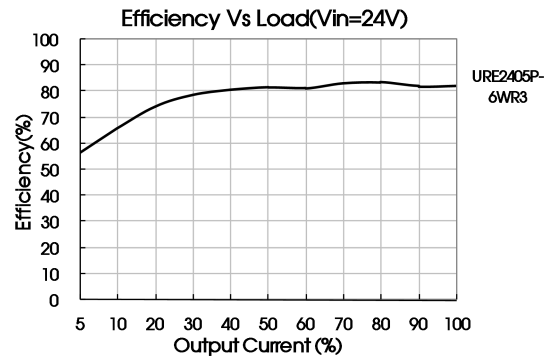
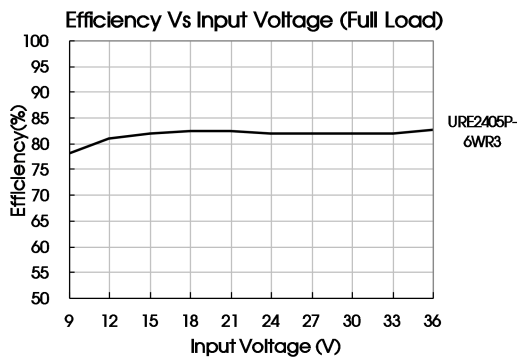

Fig. 1



Design Reference

1. Typical application

All the DC/DC converters of this series are tested according to the recommended circuit (see Fig. 2) before delivery. If it is required to further reduce input and output ripple, properly increase the input & output of additional capacitors Cin and Cout or select capacitors of low equivalent impedance provided that the capacitance is no larger than the max. capacitive load of the product.

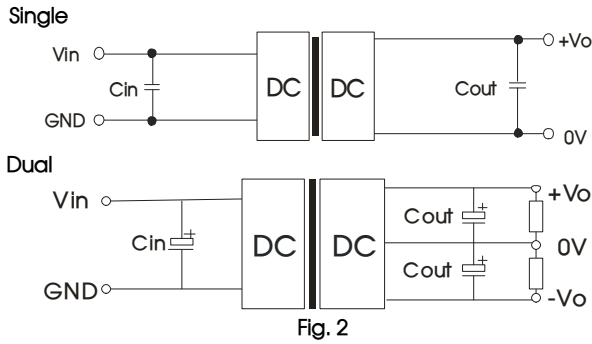

Vin(VDC)	Cin(μ F)	Cout(μ F)
24	100	10
48	10~47	10

2. EMC solution-recommended circuit

URE_P-6WR3 & URF_P-6WR3:

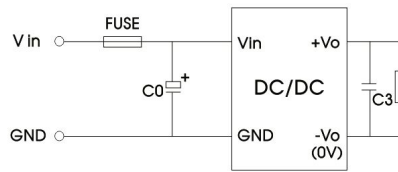
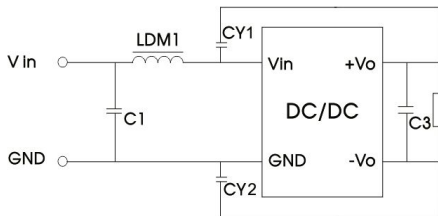

Fig. 3-①

URE_P-6WR3:



URF_P-6WR3:

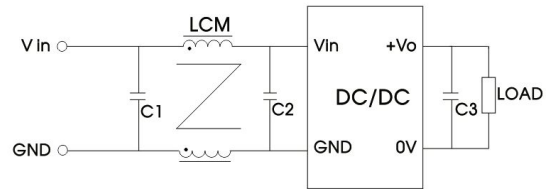

Fig. 3-②

Notes: Part ① in the Fig. 3 is used for EMS test and part ② for EMI filtering; selected based on needs.

Parameter description

URE_P-6WR3	
Model	Vin:24V
FUSE	Choose according to actual input current
C0	1000 μ F/50V
C1	1 μ F/50V
C3	Refer to the Cout in Fig.2
LDM1	4.7 μ H
CY1, CY2	1nF/3KV

Parameter description

URF_P-6WR3		
Model	Vin:24V	Vin:48V
FUSE	Choose according to actual input current	
C0	1000 μ F/50V	680 μ F/100V
C1,C2	2.2 μ F/50V	2.2 μ F/100V
LCM	2.2 mH, recommended to use MORNSUN's FL2D-30-222	
C3	Refer to the Cout in Fig.2	

3. It is not allowed to connect modules output in parallel to enlarge the power

4. For more information please find DC-DC converter application notes on www.mornsun-power.com

Dimensions and Recommended Layout

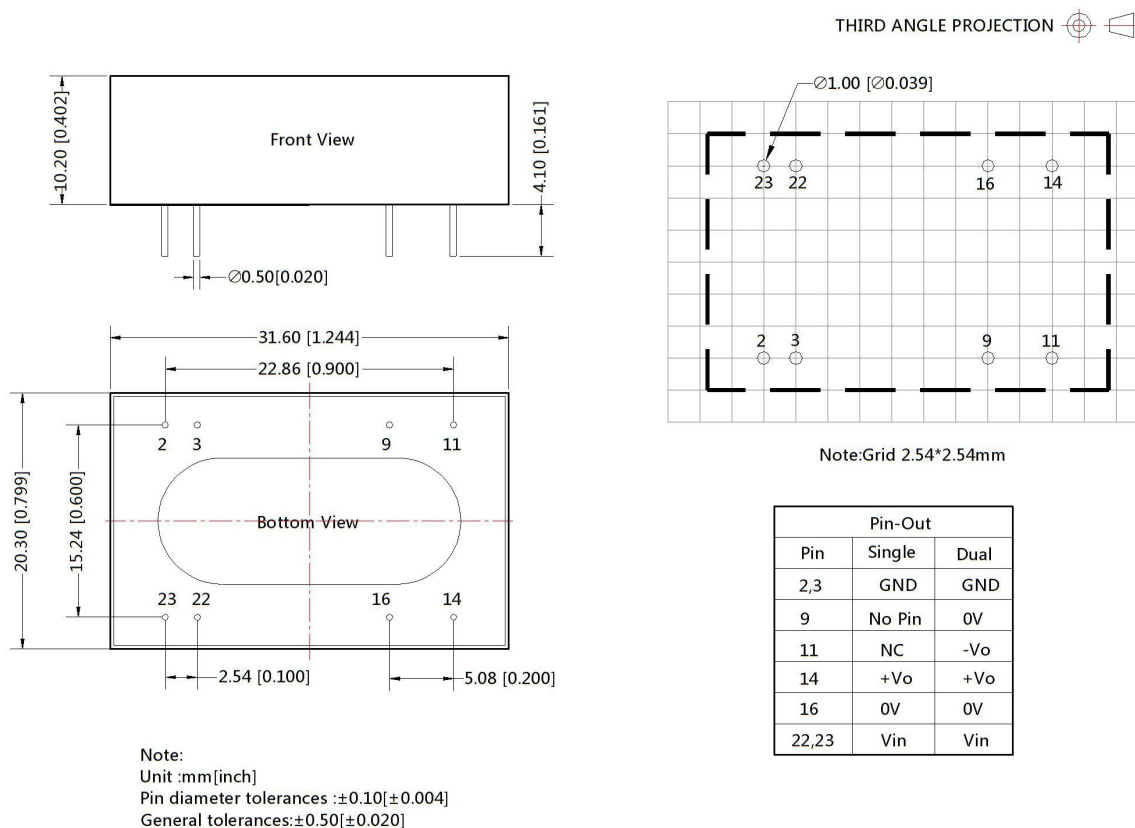

- Note:
1. Packing information please refer to Product Packing Information which can be downloaded from www.mornsun-power.com.The Packing bag number of Horizontal package: 58210008;
 2. The max. capacitive load should be tested within the input voltage range and under full load conditions;
 3. Unless otherwise specified, data in this datasheet should be tested under the conditions of Ta=25°C, humidity<75%RH when inputting nominal voltage and outputting rated load;
 4. The recommended unbalance degree of the dual output module load is ≤±5%; if the degree exceeds ±5%, the product performance cannot be guaranteed to comply with all parameters in the datasheet. Please contact our technicians directly for specific information;
 5. All index testing methods in this datasheet are based on our Company's corporate standards;
 6. The performance indexes of the product models listed in this datasheet are as above, but some indexes of non-standard model products will exceed the above-mentioned requirements, and please directly contact our technicians for specific information;
 7. We can provide product customization service;
 8. Products are related to laws and regulations: see "Features" and "EMC";
 9. Our products shall be classified according to ISO14001 and related environmental laws and regulations, and shall be handled by qualified units.

Mornsun Guangzhou Science & Technology Co., Ltd.

Address: No. 5, Kehui St. 1, Kehui Development Center, Science Ave., Guangzhou Science City, Luogang District, Guangzhou, P. R. China
Tel: 86-20-38601850-8801 Fax: 86-20-38601272 E-mail: info@mornsun.cn