

# SPECIFICATION

[  ] Preliminary Specification

[  ] Final Specification

**Description**

**7.0” 800xRGBx480 TFT-LCD Module**

**Part Number**

**P0700WVN1MA00**

<b>Customer</b>	Industrial Product Dept, PDBU Tianma Microelectronics Co., Ltd.		
<b>Signatures</b>	<b>Date</b>	<b>Approved By</b>	<b>Date</b>
_____	_____	XiaoXing Ding	2021/11/21
_____	_____	<b>Reviewed By</b>	
		Longping Deng	2021/11/19
		<b>Prepared By</b>	
		Bin Wang	2021/11/17
<b>Comments:</b>			

\* This cover page is for your Comments and Signatures back to TIANMA.

### REVISION HISTORY

Rev	Date	Page	Revision Items	Editor
1.0	2021/11/17		Preliminary Specification release.	Bin Wang

# CONTENTS

<b>1. SUMMARY .....</b>	<b>1</b>
1.1 General Description .....	1
1.2 Features .....	1
<b>2. GENERAL SPECIFICATIONS .....</b>	<b>2</b>
<b>3. INPUT / OUTPUT TERMINALS .....</b>	<b>3</b>
3.1 CN1 Pin assignment (LCD Interface).....	3
3.2 U/D R/L Function Description.....	4
<b>4. ABSOLUTE MAXIMUM RATINGS .....</b>	<b>5</b>
<b>5. ELECTRICAL CHARACTERISTICS.....</b>	<b>6</b>
5.1 DC Characteristics for Panel Driving .....	6
5.2 Panel Power Consumption .....	6
5.3 DC Characteristics for Panel Driving .....	7
5.4 Recommended Power ON/OFF Sequence .....	8
5.5 LCD Module Block Diagram.....	8
<b>6. TIMING CHARACTERISTICS.....</b>	<b>9</b>
6.1 AC characteristics .....	9
6.2 Data Input Timing Parameter Setting.....	10
<b>7. OPTICAL CHARACTERISTICS.....</b>	<b>12</b>
<b>8. RELIABILITY TEST .....</b>	<b>15</b>
<b>9. MECHANICAL DRAWING .....</b>	<b>16</b>
<b>10. PACKING INSTRUCTION .....</b>	<b>17</b>
<b>11. PRECAUTIONS FOR USE OF LCD MODULES .....</b>	<b>18</b>
11.1 Handling Precautions .....	18
11.2 Storage precautions .....	18
11.3 Transportation Precautions .....	18
11.4 Screen saver Precautions .....	18
11.5 Safety Precautions .....	18

## 1. Summary

### 1.1 General Description

This is a 7.0 inch a-Si TFT-LCD module with Normal- White technology. It is composed of a TFT-LCD panel, a driver circuit, FPC, Bezel, and Backlight unit.

### 1.2 Features

- High luminance.
- Long LED life time.
- Wide temperature range.
- Interface: RGB 24 bits.
  
- Acquisition product for UL62368-1/CSA C22.2 No.xxxxxx.
- Compliant with the European RoHS Directive (2011/65/EU) and Delegated Directive (2015/863/EU, Amending Annex II of 2011/65/EU).

## 2. General Specifications

	Feature	Spec	Unit
<b>Display Spec</b>	Size	7.0 inches	
	Resolution	800x480	
	Pixel Pitch	0.1926 x 0.1790	mm
	TFT Active Area	154.08 (W) x 85.92 (H)	mm
	Technology Type	a-Si	
	Pixel Configuration	R.G.B Vertical Stripe	
	Display Mode	TM, Normally White	
	Surface Treatment	Anti-Glare	
	Viewing Direction	12 o'clock	
<b>Mechanical Characteristics</b>	LCM (W x H x D)	164.9x 100 x 5.7	mm
	Weight	160	g
<b>Optical Characteristics</b>	Luminance	Min:800 Typ:1000	cd/m2
	Contrast Ratio	Min:600 Typ:1000:1	
	NTSC	Min:45 Typ:50	%
	Viewing Angle	60/70/70/70	degree
<b>Electrical Characteristics</b>	Interface	RGB 24 bits with TCON	
	Color Depth	16.7 Million color	color
	Power Consumption	LCD:400; Backlight:1920	mW

Table 2.1 General TFT Specifications

### 3. Input / Output Terminals

#### 3.1 CN1 Pin assignment (LCD Interface)

Connector Information	
Matching connector	FH12A-50S-0.5H

Table 3.1.1 Connector information

PIN	Symbol	I/O	Description	Remark
1	VLED+	P	Led anode	
2	VLED+	P	Led anode	
3	VLED-	P	Led cathode	
4	VLED-	P	Led cathode	
5	GND	P	Ground	
6	NC	NC		
7	DVDD	P	Digital power supply	
8	MODE	I	DE/SYNC mode select. H:DE mode, L:SYNC mode	
9	DE	I	Data enable signal, active high to enable data,if not used,please pull low	
10	VS	I	Vertical sync input, negative polarity,if not used,please pull High	
11	HS	I	Horizontal sync input, negative polarity,if not used,please pull High	
12	B7	I	Blue data (MSB)	
13	B6	I	Blue data	
14	B5	I	Blue data	
15	B4	I	Blue data	
16	B3	I	Blue data	
17	B2	I	Blue data	
18	B1	I	Blue data	
19	B0	I	Blue data (LSB)	
20	G7	I	Green data (MSB)	
21	G6	I	Green data	
22	G5	I	Green data	
23	G4	I	Green data	
24	G3	I	Green data	
25	G2	I	Green data	
26	G1	I	Green data	
27	G0	I	Green data (LSB)	
28	R7	I	Red data (MSB)	
29	R6	I	Red data	
30	R5	I	Red data	
31	R4	I	Red data	
32	R3	I	Red data	
33	R2	I	Red data	
34	R1	I	Red data	
35	R0	I	Red data (LSB)	
36	GND	P	Ground	
37	DCLK	I	Clock for input data	
38	GND	P	Ground	
39	L/R	I	Source left or right sequence control	

40	U/D	I	Gate up or down scan control	
41	VGH	P	Positive power of TFT	
42	VGL	P	Negative power of TFT	
43	AVDD	P	Analog power supply	
44	RESET	I	Global reset pin	
45	NC	NC		
46	NC	NC		
47	DITHB	I	Dithering setting. H: 6bit resolution, L: 8bit resolution	
48	GND	P	Ground	
49	NC	NC		
50	NC	NC		

**Table 3.1.2 Pin Assignment for LCD Interface**

Note1: I---Input, O---Output, P--- Power/Ground

Note2: All of the GND Pins should be connected to the system ground.

Note3: Please set to GND if pin is NOT in use.

### 3.2 U/D R/L Function Description

Scan control input		Scanning direction
U/D	L/R	
GND	VCC	Up to down, left to right
VCC	GND	Down to up, right to left
GND	GND	Up to down, right to left
VCC	VCC	Down to up, left to right

**Table 3.2.2 U/D R/L Function Description**

#### 4. Absolute Maximum Ratings

Item	Symbol	MIN	MAX	Unit	Remark
Power Voltage	DVDD	-0.50	3.95	V	
	AVDD	-0.50	14.95	V	
	VGH	-0.30	42.00	V	
	VGL	-20.00	0.30	V	
	VGH-VGL	-0.30	40.00	V	
Operating Temperature	T <sub>op</sub>	-30	85	°C	
Storage Temperature	T <sub>st</sub>	-40	90	°C	
Relative Humidity Note1	RH	--	≤95	%	Ta≤40°C
		--	≤85	%	40°C < Ta ≤ 50°C
		--	≤55	%	50°C < Ta ≤ 60°C
		--	≤36	%	60°C < Ta ≤ 70°C
		--	≤24	%	70°C < Ta ≤ 80°C
Absolute Humidity	AH	--	≤70	g/m <sup>3</sup>	Ta > 80°C

**Table 4.1 Absolute Maximum Ratings**

Note1: Ta means the ambient temperature. It is necessary to limit the relative humidity to the specified temperature range. Condensation on the module is not allowed.

Note2: The absolute maximum rating values of this product are not allowed to be exceeded at any times. A module should be used with any of the absolute maximum ratings exceeded, the characteristics of the module may not be recovered, or in an extreme condition, the module may be permanently destroyed



## 5. Electrical Characteristics

### 5.1 DC Characteristics for Panel Driving

Item	Symbol	MIN	TYP	MAX	Unit	Remark
Digital supply Voltage	DVDD	3.00	3.30	3.60	V	
Analog supply Voltage	AVDD	10.3	10.4	10.5	V	
Gate on voltage	VGH	14.4	16	17.6	V	
Gate off voltage	VGL	-7.70	-7.00	-6.30	V	
Input Signal Voltage	Low Level	$V_{IL}$	0	-	$0.3 \times DVDD$	R0~R7,G0~G7,0~B7,DE, DCLK,HS,VS,MODE, RESET,LR,UD, DITHB
	High Level	$V_{IH}$	$0.7 \times DVDD$	-	DVDD	

Table 5.1.1 Operating Voltages

Note : The value is for design stage only.

### 5.2 Panel Power Consumption

Item	Symbol	Condition	Min	Typ.	Max	Unit	Remark
Digital Supply Current	$I_{DVDD}$	DVDD=3.3V	-	8	15	mA	-
Analog Supply Current	$I_{AVDD}$	AVDD=10.4V	-	20	30	mA	-
Gate On Current	$I_{VGH}$	VGH=16V	-	0.4	0.8	mA	-
Gate Off Current	$I_{VGL}$	VGL=-7V	-	0.8	1.6	mA	-
Power Consumption	Panel		-	250	400	mW	-

Table 5.2.1 Panel Power Consumption

### 5.3 DC Characteristics for Backlight Driving

Item	Symbol	MIN	TYP	MAX	Unit	Remark
Forward Current	$I_F$	-	200	-	mA	24 LEDs (3 LED Serial, 8 LED Parallel)
Forward Current Voltage	$V_F$	-	9.6	10.8	V	
Backlight Power Consumption	$W_{BL}$	-	1920	-	mW	
Operating Life Time	--	--	50000	--	hrs	Note 2, Note 3

Table 5.3.1 LED Backlight Characteristics

Note1: The LED driving condition is defined for each module (3 LED Serial, 8 LED Parallel).

Note2: When LCM is operated, the stable forward current should be inputted. And forward voltage is for reference only.

Note3: Optical performance should be evaluated at  $T_a=25^{\circ}\text{C}$  When LED is driven at high current, high ambient temperature & humidity condition. The life time of LED will be reduced. Operating life means brightness goes down to 50% initial brightness. Typical operating life time is estimated data.

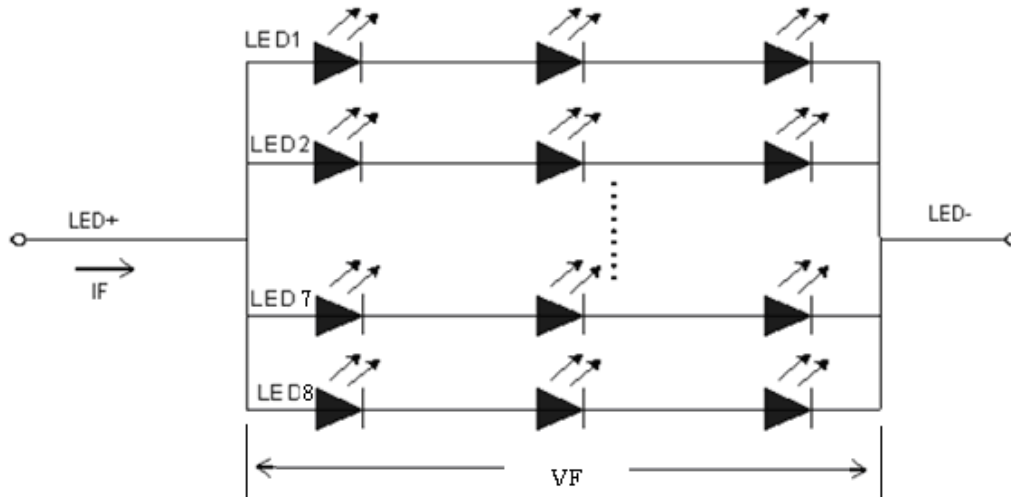

Table 5.3.2 LED connection of backlight

### 5.4 Recommended Power ON/OFF Sequence

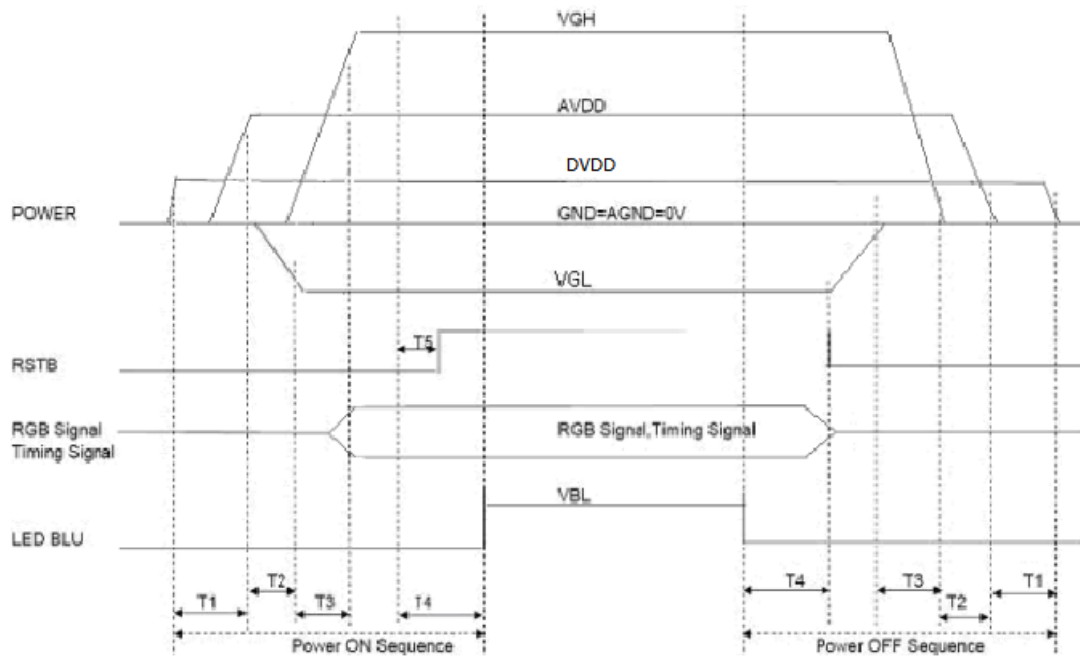

Table 5.4.1 Power On/off sequence

Note1: T1≥20ms, T2≥20ms, T3≥5ms, T4≥100ms, T5≥5ms.

Note2: If some of display and function signals of this product are cut while this product is working, even if the signal input to it once again, it might not work normally. If a customer stops the display and function signals, VCC also must be shut down.

Note3: The backlight should be turned on within the valid period of display and function signals, in order to avoid unstable data display.

Note4: FR=Frame rate=60Hz.

### 5.5 LCD Module Block Diagram

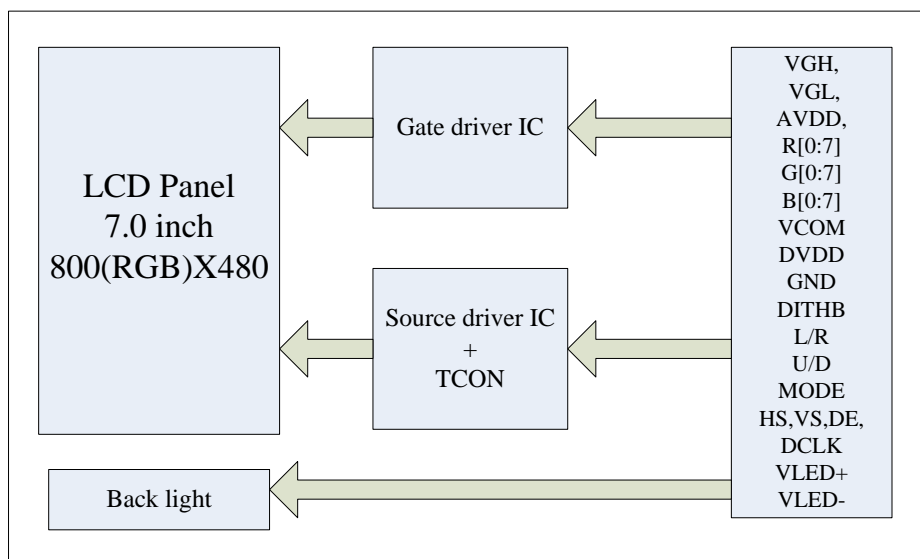

Table 5.5.1 LCD Module Block Diagram

## 6. Timing Characteristics

### 6.1 AC characteristics

Parameter	Symbol	Min	Typ	Max	Unit	Remark
DCLK frequency	$F_{clk}$	28	30.0	40.0	MHz	
DCLK cycle time	$T_{cph}$	25	33.3	36	ns	
DCLK pulse width	$T_{cw}$	40%	50%	60%	$T_{cph}$	
VS setup time	$T_{vst}$	8	-	--	ns	
VS hold time	$T_{vhd}$	8	-	-	ns	
HS setup time	$T_{hst}$	8	-	-	ns	
HS hold time	$T_{hhd}$	8	-	-	ns	
Data setup time	$T_{dsu}$	8	-	-	ns	Data to DCLK
Data hold time	$T_{dhd}$	8	-	-	ns	Data to DCLK
DE setup time	$T_{esu}$	8	-	-	ns	
DE hold time	$T_{ehd}$	8	-	-	ns	

Table 6.1.1 LVDS interface AC characteristic

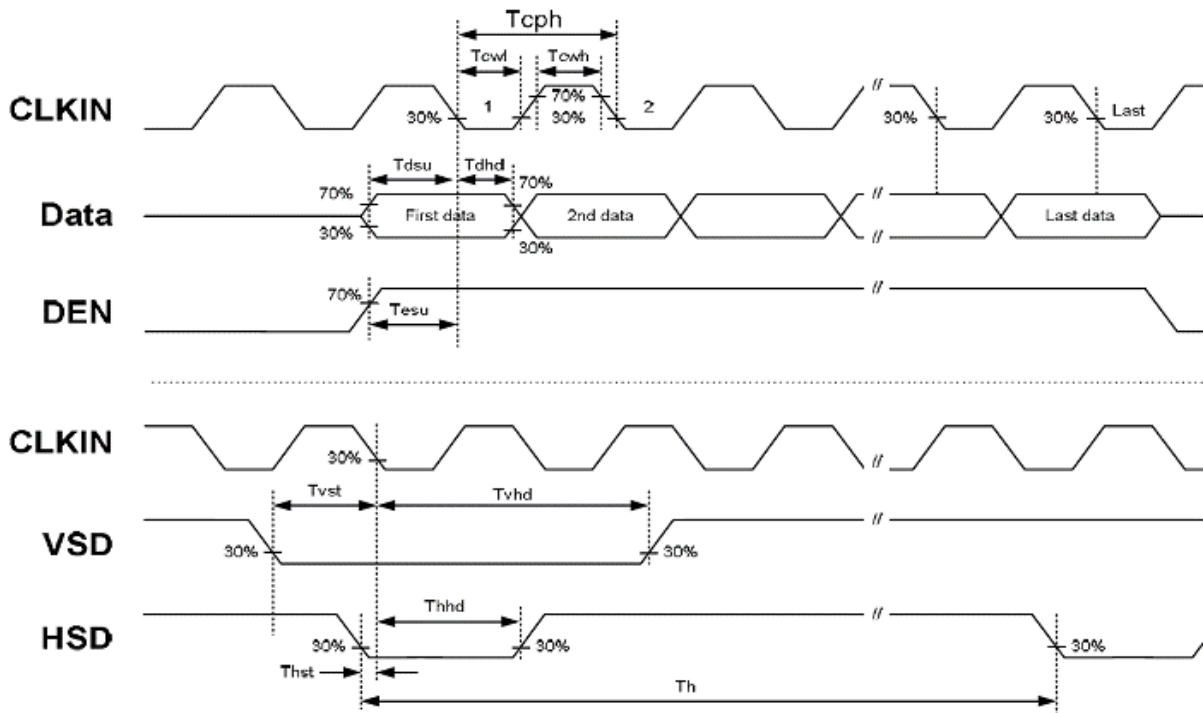

Table 6.1.2 Clock and Data Input Timing Diagram

## 6.2 Data Input Timing Parameter Setting

### TCON (Embedded In Source IC) Input Timing (DCLK, HS, VS, DE)

Parameter	Symbol	Min	Typ	Max	Unit	Remark
DCLK	F <sub>clk</sub>	28	30	40	MHZ	
	t <sub>clk</sub>	20	33.3	36	ns	
HSD	t <sub>h</sub>	862	1056	1200	t <sub>clk</sub>	
	t <sub>hd</sub>	800	800	800	t <sub>clk</sub>	
	t <sub>hpw</sub>	1	-	40	t <sub>clk</sub>	
	t <sub>hb</sub>	46	46	46	t <sub>clk</sub>	
	t <sub>hfp</sub>	16	210	354	t <sub>clk</sub>	
	VSD	t <sub>v</sub>	510	525	650	th
VSD	t <sub>vd</sub>	480	480	480	th	
	t <sub>vpw</sub>	1	3	20	th	
	t <sub>vb</sub>	23	23	23	th	
	t <sub>vfp</sub>	7	22	147	th	

Table 6.2.1 Data Input Timing Parameters

Note 1: DE timing refer to HS, VS input timing.

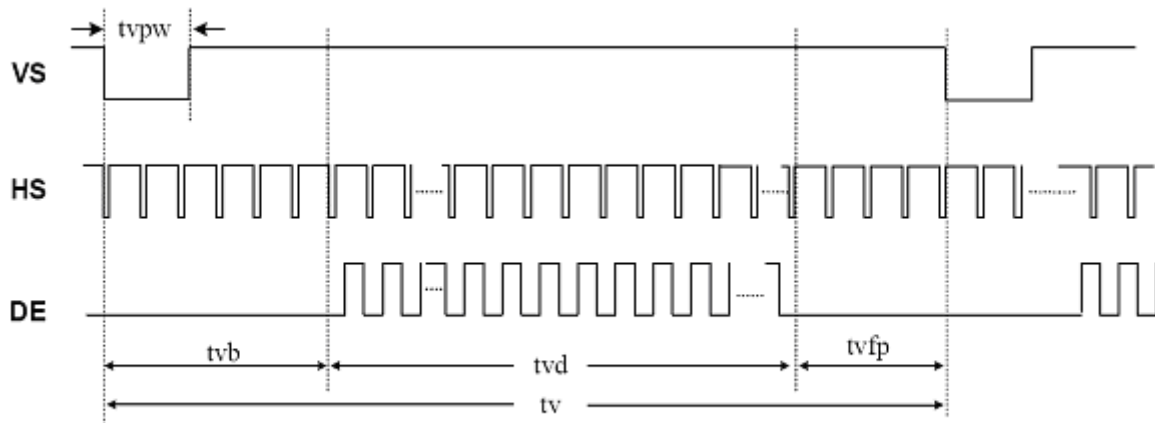

Table 6.2.2 TCON Vertical Input Timing Diagram HV

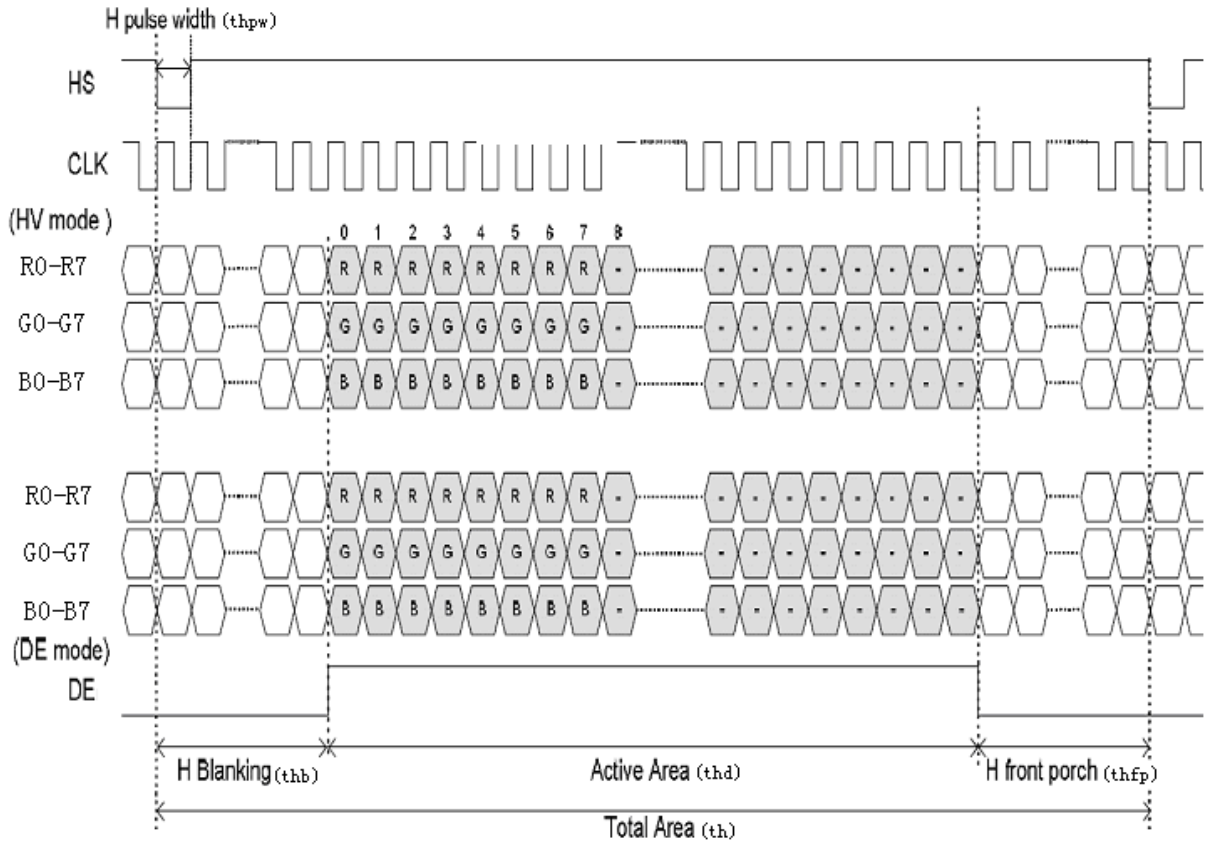

Table 6.2.3 TCON Horizontal Input Timing Diagram

## 7. Optical Characteristics

Item	Symbol	Condition	Min	Typ	Max	Unit	Remark
View Angles	$\theta T$	$CR \geq 10$	50	60	-	Degree	Note 2
	$\theta B$		60	70	-		
	$\theta L$		60	70	-		
	$\theta R$		60	70	-		
Contrast Ratio	CR	$\theta=0^\circ$	600	1000	-		Note1 Note3
Response Time	$T_{ON}$	$25^\circ C$	-	25	-	ms	Note1 Note4
	$T_{OFF}$						
Chromaticity	White	Backlight is on	x	0.276	0.326	0.376	Note1 Note5
			y	0.305	0.355	0.405	
	Red		x	0.549	0.599	0.649	
			y	0.298	0.348	0.398	
	Green		x	0.284	0.334	0.384	
			y	0.545	0.595	0.645	
	Blue		x	0.100	0.150	0.200	
			y	0.067	0.117	0.167	
Uniformity	U		70	75	-	%	Note1 Note6
NTSC			45	50	-	%	Note 5
Luminance	L		800	1000	-	cd/m <sup>2</sup>	Note1 Note7

Table 7.1 Optical Parameters

Test Conditions:

- $I_F=160\text{ mA/LED}$ ,  $V_F=9.6\text{ V}$  and the ambient temperature is  $25\pm 2^\circ C$ .humidity is  $65\pm 7\%$
- The test systems refer to Note1 and Note2.

Note1: Definition of optical measurement system.

The optical characteristics should be measured in dark room. After 5 Minutes operation, the optical characteristics are measured at the center point of the LCD screen.

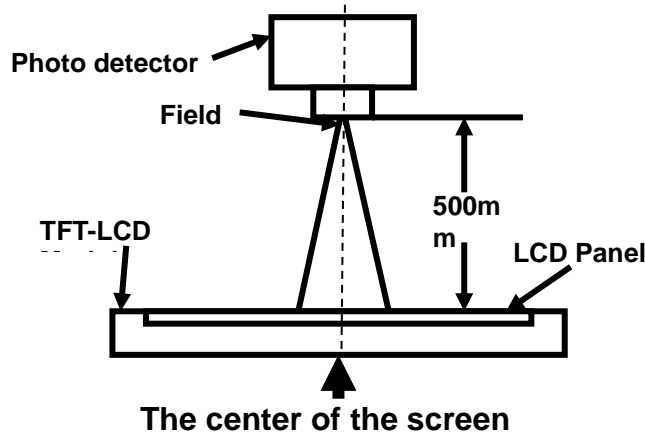

Fig1. Measurement Set Up

Note2: Definition of viewing angle range and measurement system. Viewing angle is measured at the center point of the LCD .

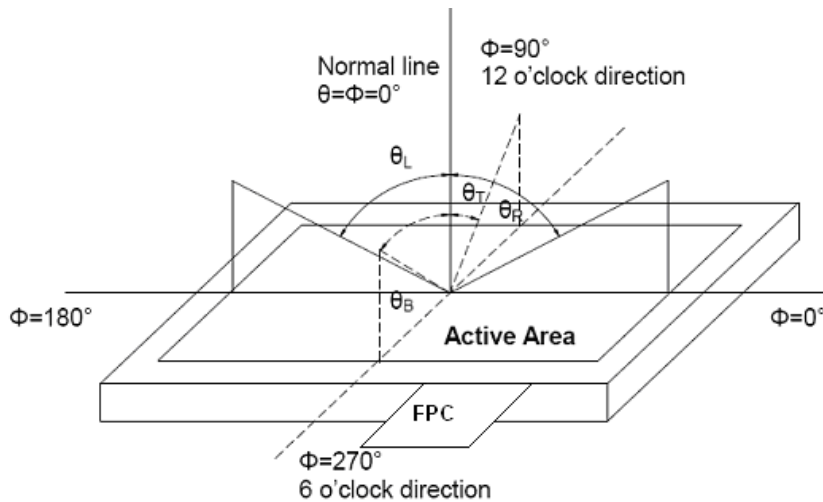

Fig2. Measurement viewing angle

Note3: Definition of contrast ratio

$$\text{Contrast ratio (CR)} = \frac{\text{Luminance measured when LCD is on the "White" state}}{\text{Luminance measured when LCD is on the "Black" state}}$$

Note4: Definition of Response time

For TN LCM, the response time is defined as the LCD optical switching time interval between “White” state and “Black” state. Rise time ( $T_r$ ) is the time between photo detector output intensity changed from 90% to 10%. And fall time ( $T_f$ ) is the time between photo detector output intensity changed from 10% to 90%.



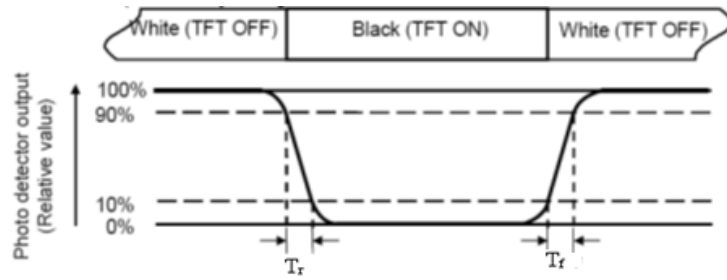

Fig3. Response Time Testing(TN)

For SFT LCM, the response time is defined as the LCD optical switching time interval between “White” state and “Black” state. Rise time ( $T_r$ ) is the time between photo detector output intensity changed from 10% to 90%. And fall time ( $T_f$ ) is the time between photo detector output intensity changed from 90% to 10%.

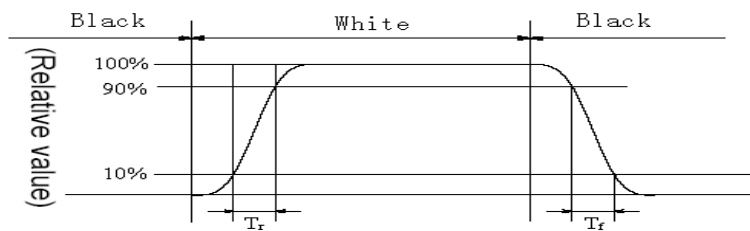

Fig4. Response Time Testing(SFT)

Note5: Definition of color chromaticity (CIE1931)

Color coordinates measured at center point of LCD.

Note6: Definition of Luminance Uniformity

Active area is divided into 9 measuring areas (Refer Fig.5). Every measuring point is placed at the center of each measuring area.

$$\text{Luminance Uniformity (U)} = L_{\min} / L_{\max}$$

$L_{\max}$ : The measured Maximum luminance of all measurement position.

$L_{\min}$ : The measured Minimum luminance of all measurement position.

L-----Active area length; W----- Active area width

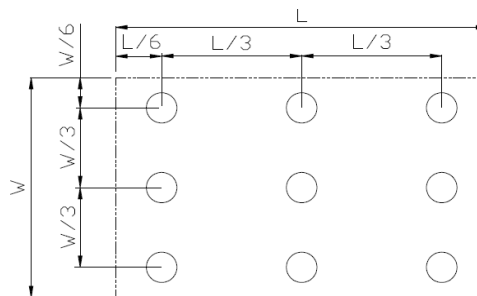

Fig5. Luminance Uniformity Measurement Locations(9 points)

Note7: Definition of Luminance:

Measure the luminance of white state at center point.

## 8. Reliability Test

No	Test Item	Condition	Remarks
1	High Temperature Operation	Ta = +85°C, 240 hours	IEC60068-2-1 GB2423.2
2	Low Temperature Operation	Ta = -30°C, 240 hours	IEC60068-2-1 GB2423.1
3	High Temperature Storage	Ta = +90°C, 240 hours	IEC60068-2-1 GB2423.2
4	Low Temperature Storage	Ta = -40°C, 240 hours	IEC60068-2-1 GB2423.1
5	High Temperature and Humidity Operation	Ta = +60°C, 90% RH max,240hours	IEC60068-2-78 GB/T2423.3
6	Thermal Shock (non-operation)	-30°C 30 min~+80°C 30 min, Change time:5min, 100 Cycle	Start with cold temperature, End with high temperature, IEC60068-2-14,GB2423.22
7	ESD	C=150pF,R=330Ω,5point/panel Air:±8Kv,5times; Contact:±4Kv,5times (Environment:15°C~35°C, 30%~60%.86Kpa~106Kpa)	IEC61000-4-2 GB/T17626.2
8	Vibration Test	①sinusoidal vibration: 30HZ,4G, vertical 4hrs; horizontal 2hrs for left, right, front and rear, total 8hrs ②Vibration Level: 66.64 m/s <sup>2</sup> (6.8G) Waveform: sinusoidal Frequency range:20~500Hz Duration: each x, y, z axis:1 hour, total 3 hours	GB/T 2423.10-2008 ; GB/T 2423.56-2006
9	Shock Test	150G 3ms ±X,±Y,±Z 1 times for each direction, total 6 times	GB/T 2423.5-1995
10	Package Drop Test	Height:60cm, 1corner,3edges,6surfaces	GB/T 4857.5-1992

**Table 8.1 RA test condition**

Note1: Ts is the temperature of panel's surface.

Note2: Ta is the ambient temperature of sample.

Note3: Before cosmetic and function test, the product must have enough recovery time, at least 24 hours at room temperature.

Note 4: In the standard condition, there shall be no practical problem that may affect the display function. After the reliability test, only guarantee the operation of the product, but don't guarantee all of the cosmetic specification.

9. Mechanical Drawing

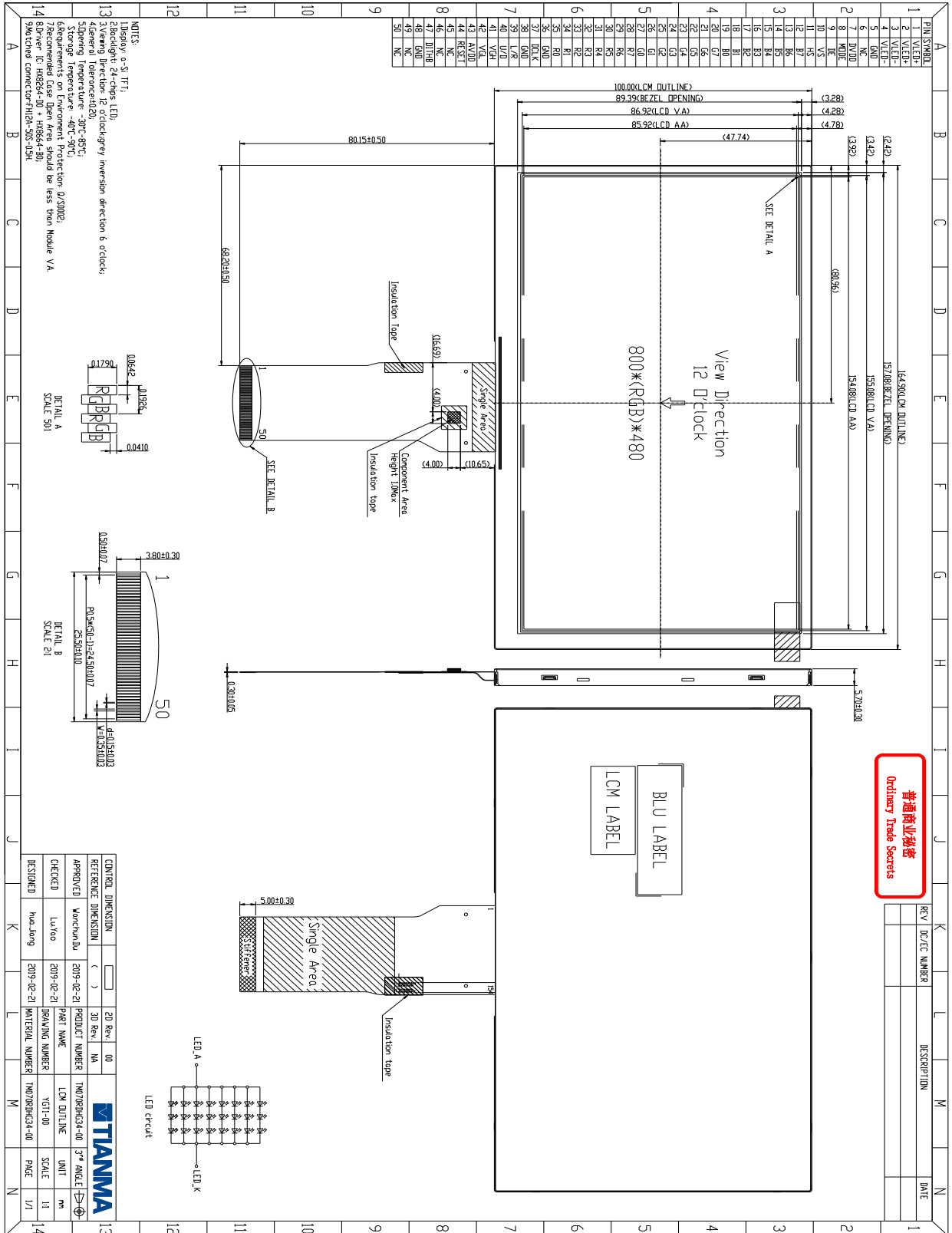
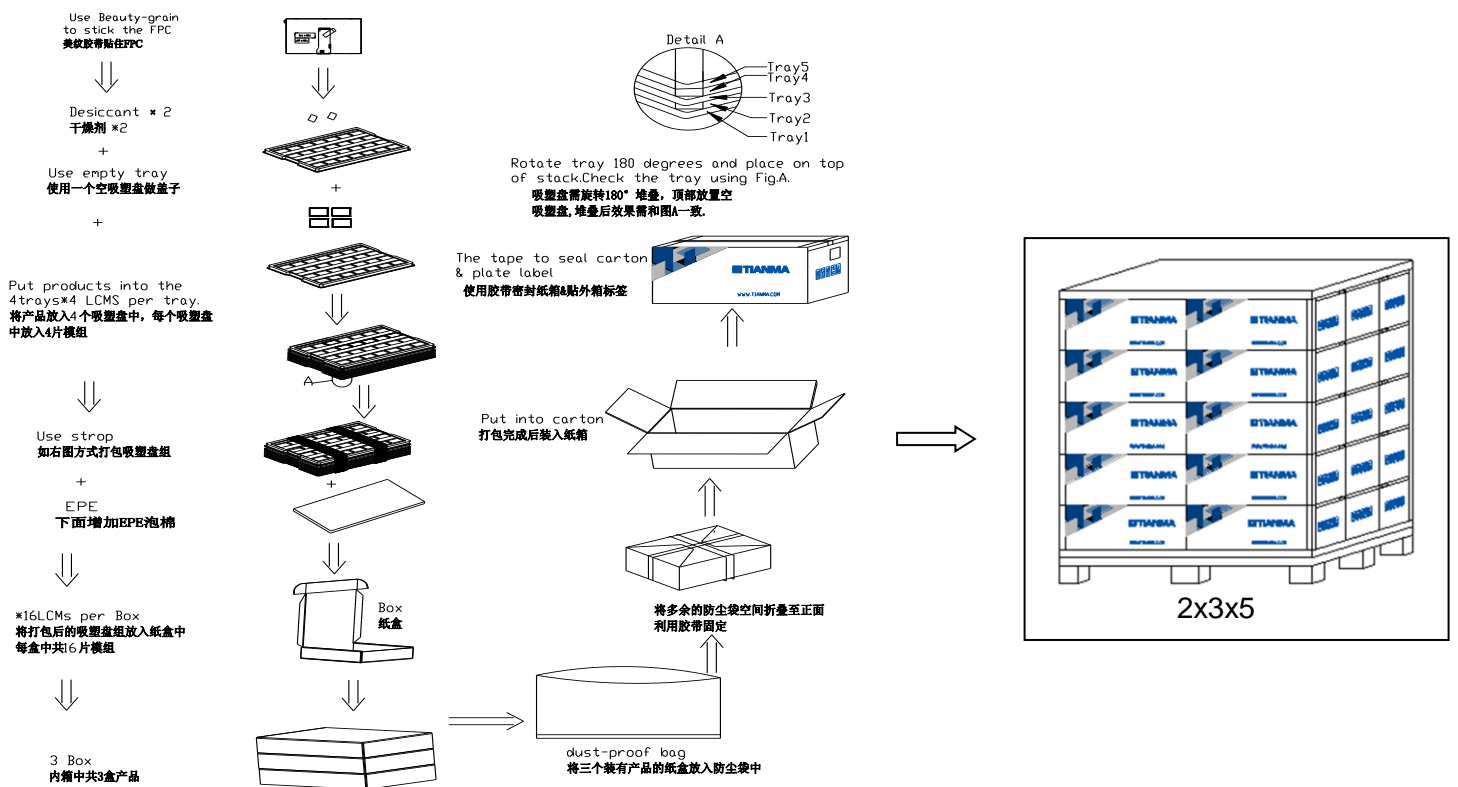

Table 9.1 Mechanical Drawing

### 10. Packing Instruction

No	Item	Model (Material)	Dimensions(mm)	Unit Weight(Kg)	Quantity	Remark
1	LCM module	P0700WVN1MA00	164.90x100.00x5.7	0.160	48	
2	Tray	PET(Transmit)	485x330x17	0.202	15	
3.	Dust-proof bag	PE	700x545	0.046	1	
4	EPE	EPE	485x330x5	0.08	3	
5	BOX	CORRUGATED PAPER	520x345x74	0.40	3	
6	Desiccant	DESICCANT	45x35	0.002	6	
7	Carton	CORRUGATED PAPER	544x365x250	1.01	1	
8	Label	PP	100x52	0.001	1	
9	Beauty-grain	Beauty-grain	30x10	48		
10	Total weight	13.3±5%Kg				



## 11. Precautions for Use of LCD Modules

### 11.1 Handling Precautions

- (1) The display panel is made of glass. Do not subject it to mechanical shock by dropping it, etc.
- (2) If the display panel is damaged and the liquid crystal fluid inside it leaks out be sure not to get any in your mouth. If the fluid comes into contact with your skin or clothes promptly wash it off using soap and water.
- (3) Do not apply excessive force to the display surface or the bezel since this may cause the color tone to vary.
- (4) The polarizer covering the display surface of the LCD module is soft and easily scratched. Handle the polarizer carefully.
- (5) If the display surface is contaminated, breathe on the surface and gently wipe it with a soft dry cloth. If it is still not completely clear use a moist cloth with one of the following solvents:
  - Isopropyl alcohol
  - Ethyl alcoholSolvents other than those mentioned above may damage the polarizer. Specifically, do not use the following:
  - Water
  - Ketone
  - Aromatic solvents
- (6) Do not disassemble the LCD Module.
- (7) If powered off, do not apply the input signals.
- (8) To prevent destruction of the module by static electricity, be careful to maintain an optimum work environment.
- (9) Be sure to ground your body when handling the LCD Modules.
- (10) Tools used for assembly, must be properly grounded.
- (11) To reduce the amount of static electricity generated, do not conduct assembly or other work under very low humidity conditions.
- (12) The LCD Module is covered with a film to protect the display surface, remove film slowly under the ionizer.

### 11.2 Storage precautions

- (1) When storing the LCD modules avoid exposure to direct sunlight or to the light of fluorescent lamps.
- (2) The LCD modules should be stored within the rated storage temperature range. The recommend condition is: Temperature: 0 ~ 35 °C at normal humidity.
- (3) The LCD modules should be stored in a room without acid, alkali or other harmful gas.

### 11.3 Transportation Precautions

The LCD modules should not be dropped or subject to violent mechanical shock during transportation. Also they should avoid excessive pressure, water, high humidity and direct sunlight.

### 11.4 Screen saver Precautions

Not display the fixed pattern for a long time. Use a screen saver, if the fixed pattern is displayed on the screen

### 11.5 Safety Precautions

- (1) When you waste damaged or unnecessary LCDs, it is recommended to crush LCDs into pieces and wash them off with solvents such as acetone and ethanol, which should later be burned
- (2) Be sure to turn off the power supply when inserting or disconnecting the LED backlight cable.
- (3) LED driver should be designed to limit or stop its function when over current is detected on the LED.