



承认书

SPECIFICATION FOR APPROVAL

PRODUCT/产品名称	LED BACKLIGHT INVERTER LED 背光源
MY P/N 型号	BTP-1L2136A
VERSION P/N 版本	V 2.1
CUSTOMER/客户	
CUSTOMER P/N 客户物料编号	
CUSTOMER APPROVE 承 认	请承认后签章回传 201 / /



1. General Description/概述

This DC-DC LED Inverter was developed for LCD back lighting system with lighting use LED.

本产品为直流-直流逆变器，适用于 LED 背光的液晶显示模块。

2. Features /特性

High performance, low consumption. / 具有高能低耗特点

LED short protection / LED 灯短路保护功能

Wide Dimming Range / 宽范围调光

LED constant current drive/ LED 恒流驱动

Input current overload protected (fuse protect)./ 输入过流保护（保险丝保护）

3. Application /适用范围

The DC to AC back-light inverter is special designed on any type LCD display in implement (i.e. LCD monitor, notebook、laptop computers etc.) / 本产品专为各种液晶显示部件设计（例：LED 背光显示器，笔记本电脑，掌上电脑等）。

4. Suitable load /适用负载

22" to 40(LED backlight)display/ 22 寸到 40 寸(LED 背光)显示器

5. Environmental Condition /适用环境条件

Operating temperature /工作温度 : -5°C -- 50°C

Storage temperature / 贮存温度 : -20°C-- 70°C

Operating humidity / 工作湿度 : 10% -- 95%RH

Storage humidity / 贮存湿度 : 10% -- 95%RH

The DC to DC back-light inverter suggested working in the condition of upon. It can be work 50thousand hours at least in the below condition.

本产品建议在以上条件下工作，在下列条件下可以工作 5 万小时。

Operating temperature /工作温度: -20——70°C

Operating humidity /工作湿度: 10%——95%RH

6. Input Electrical Characteristics /输入参数

NO	Item/项目	Symbol	Min	Type	Max	Unit
1	Input Voltage/输入电压	Vin	10.8	12/24	26.4	V
2	Input Current/输入电流	Iin	0.4	1.7/0.85	2.5	A
3	Input Power/输入功率	Pin	----	19.7	35	W
4	Brightness Voltage/调亮控制电压	Vadj	0 (bright)	--	3.3(dark)	V
5	Control Voltage/ 开关机控制电压	Enable	Von=1.5---5.0V	Disable	Voff=0---0.5V	



7. Output electrical characteristics / 输出电气参数

Item 项目	Symbol 符号	Test Conditions 测试条件	Min 最小值	Type 规格值	Max 最大值	Unit 单位
Output Current (per group) 每组输出电流	Iout _{pg}	V _{in} =24.0V; V _{on} =3.3V; V _{adj} =0V		360		mA
Output Voltage 输出电压	Vout	V _{in} =24.0V; V _{on} =3.3V; V _{adj} =0V	42	62	80	V
Efficiency 效率	η	V _{in} =24.0V; V _{on} =3.3V; V _{adj} =0V		93	---	%
Output total group 输出总组数	Ggp	1		1		
The Total Output Current 输出总电流	R			360		mA
						mA
	R					mA
						mA

The parameter of upon will change when the LCD module changes/以上参数随屏的不同而有所变化。

8. Pin assignments / 插座引脚定义

Input connector /输入插座: CN1			
Pin No./引脚	Symbol/符号	Description/ 描述	Parameter /参数
1、2	VCC	Supply voltage/供电	10.8~26.4V
5、6	GND	Ground/接地	0V
4	ADJ	Dimming control/亮度控制	0V=Brightness Max 亮度最大 3.3V=Brightness Min 亮度最小
4	ADJ	PWM 调光控制 100-1000Hz	100%=Brightness Max 亮度最大 10%=Brightness Min 亮度最小
3	N/F	Standby/Operation/开关控制	On =2--5.0V Off=0-0.5V

Input connector /输入插座: CN2			
Pin No./引脚	Symbol/符号	Description/ 描述	Parameter /参数
1	VCC	Supply voltage/供电	10.8~26.4V
2	ADJ	Dimming control/亮度控制	An external light sensor/外接光感器
3	GND	Ground/接地	0V



Pin No./引脚						
	CN3					
	CCAACCCA AACCAA					
Symbol 符号	Description/ 描述	Parameter /参 数	Pin assignments /插座引脚定义			
A	+	30~80V	LED 高端			
C	-	0V	LED 低端			
N	-	0V	空脚			

接口示意图	接口定义	
	位置:CN3	符号: A 阳极供电 C 阴极回路
	1.接口脚间距 2.0mm 2. 1、4、5、8、9、12、13 脚为阴，2、3、6、7、10、11、14、15 为阳极，可根据屏幕参数拼接。 3.适合 2P~15P 多接口或单接口的屏。 注：可根据不同的屏参数，贴不同规格的排线座。（如 14P、12P 10P、9P、8P、6P、4P 座等。）	



9. Mechanical Dimension / 结构示意图

Dimension of P.C.B. / PCB 机械尺寸

Unit/单位: mm : Tolerance/公差: $\pm 0.5\text{mm}$

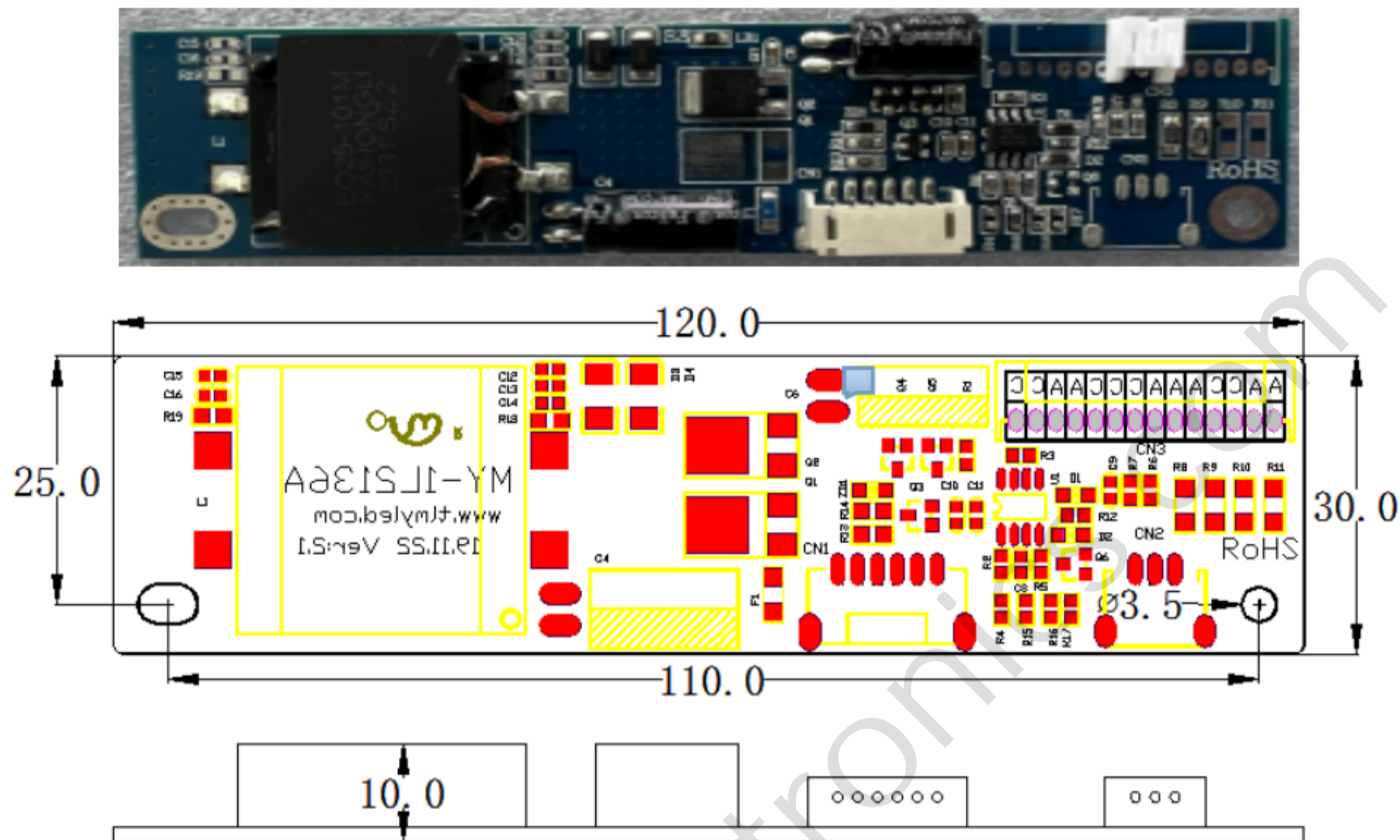

10. Notice / 注意事项

A. If some one group is not use, Please float the terminal;如果某一组输出不用悬空此路的连接端,

B. For Safety Issue, please keep 4.0mm at least from the metal parts of the system to the inverter. Or put a suitable insulator between the inverter and the metal parts to avoid the situation of breakdown.

基于安全问题,请在组装本产品时,确保本产品和整机中的金属材料间保持至少 4mm 以上的距离, 或者使用足够绝缘等级的绝缘材料进行隔离。

C. Don't twist , deform , drop or knock the inverter during assembly.

请在组装本产品时,避免扭曲,弯折,大力碰撞及跌落产生损害。

D. Guarantee to offer ESD shield bag to protect the product from electrostatic or magnetic interference during delivery. Due to the inverter is usually designed without the enclosure. *please take care about ESD at anytime* .

在产品交付的整个过程中均保证采用 ESD 屏蔽袋包装处理,因为该产品无外壳保护,请务必随时注意防静电措施。

E.The products are not intended for use in systems in which failures of product could result in personal injury.

请勿将本产品使用在非适用范围的产品上,以免造成意外伤害。



11 SAMPLE TEST REPORT/ 样品测试报告

CUSTOMER/客户:		PRODUCT NO./产品编号:	
MOOEL NO./产品型号:	MY-1L2136A	PART NO./物料号:	

1. Input Characteristics/输入特性

Parameter/参数	Symbol/符号	Min	Typ	Max	Unit/单位	Remark/备注	Spec. Limit / 参考标准	Pass/Fail / 判定结果
Input Voltage/输入电压	Vin	10.8	12/24	26.4	V	Input DC	10.8~26.4V	Pass
Input Current/输入电流	Iin	0.4	1.7/ 0.85	2.5	A	Vadj=0V	0.5~3 A	Pass
Input Power/输入功率	Pin	5	19.7	35	W			
Input Voltage ON/off control /开关电压	Von/Off	1.5~5	1.5~5	1.5~5	V	On	1.5~5	Pass
		0~0.5	0~0.5	0~0.5		Off	0~0.5	Pass
Input Current/输入电流	Ion/off				uA	On STATE		
						Off STATE		
Brightness contro currenr/调光电流	Iadj				uA	Vadj=0V		
						Vadj=5V		

2. Output Characteristics/输出特性

Parameter/参数	Symbol/符号	Min	Typ	Max	Unit/单位	Remark/备注	Spec. Limit / 参考标准	Pass/Fail / 判定结果
Output Voltage /输出电压	+	30	62	80	V		30~80	Pass
					V			Pass
Output Current/输出电流	+		360	-	mA		120~900	Pass
					mA			120~900

Low temperature test/低温启动试验 0°C,(12VDC±10%) The sample OK

Burn-in/老化测试 Burn-in test with full load at 60°C±5°C(12VDC), The sample OK

Appearance/外观目测 OK

3. Major Measure Equipment/主要测试仪器

A. OSCILLOSCOPE/示波器:Tektronix SDS1102CN	B. DIGITAL MULTIMETER/数量式万用表:ESCORT 3136A
C. DC POWER/直流输入电源: TPR-6405D	D. HI-POT TESTER/耐压测试仪:GOODEILL GPT-605
E. HYBRID RECORDER/混合记录仪:YOKOGAWA DR130	F. CONS.T/H SIMULATOR/恒温恒湿仪:TH-A4H 1-150

DATE/ 日期		EDITION/ 版本		PAGE/ 页码	
TEST/ 测试		CHECK/ 审核		APPR/ 批准	

