



INS5710A —Low Power Consumption I²C RTC

Key Features

- Low current consumption: 1.2uA (Typ.)
- High stability:
< 5±23ppm @ +25°C
- Communication Interface: I²C bus
- Power Supply Voltage: 1.6V~5.0V
- Operation Temperature Range: -40°C ~ +85°C
- Build-in XO: 32.768KHz
- Build-in temperature sensor
- Leap years autocorrection
- Package: 4.9mm × 6.0mm × 1.6mm

Block Diagram

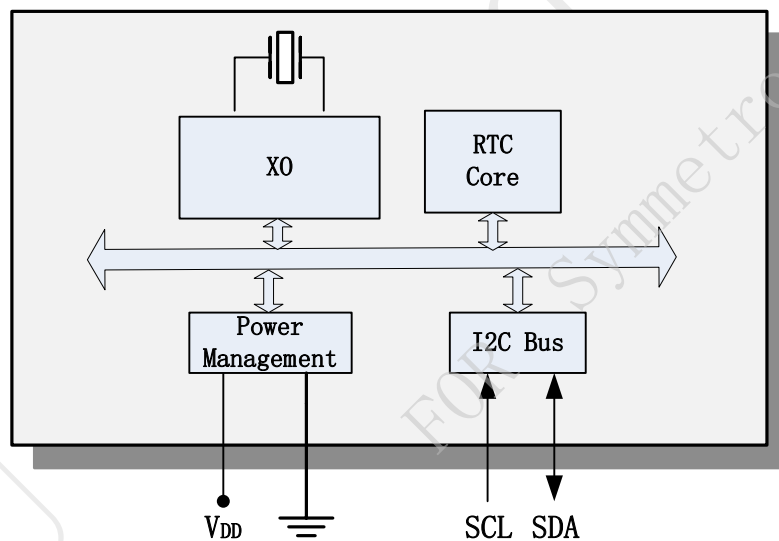

Overview

INS5710A is an I²C bus interface real-time clock with low power consumption. It embeds a 32.768KHz XO. It supports calendar (year, month, day, hour, minute, second) function. The SOP8 package makes it suitable to be used in portable electronic devices.



Revision History

Version	Change Contents	Prepared by	Revised Date
V1.0	Preliminary Version		2021.04.02
V1.1	Delete the description about temperature compensation		2021.05.06



Index

1	OVERVIEW.....	5
2	BLOCK DIAGRAM.....	5
3	FEATURES	5
4	PIN DEFINITION	6
5	ELECTRICAL CHARACTERISTICS	7
5.1	ABSOLUTE MAXIMUM RATINGS	7
5.2	RECOMMENDED OPERATING CONDITIONS.....	7
5.3	FREQUENCY CHARACTERISTICS	7
5.4	DC CHARACTERISTICS	8
5.5	AC CHARACTERISTICS.....	9
6	REGISTERS	10
6.1	REGISTER LISTS	10
6.2	DETAILS OF REGISTERS.....	12
6.2.1	<i>Clock counter registers.....</i>	<i>12</i>
6.2.2	<i>Extension registers.....</i>	<i>13</i>
6.2.3	<i>Flag registers</i>	<i>13</i>
6.2.4	<i>Control registers</i>	<i>13</i>
6.2.5	<i>Temperature register</i>	<i>13</i>
6.2.6	<i>RSV register.....</i>	<i>14</i>
6.2.7	<i>Device ID register.....</i>	<i>14</i>
6.2.8	<i>Control Register 1</i>	<i>14</i>
6.2.9	<i>Sub-second timer register.....</i>	<i>14</i>
7	I²C BUS INTERFACE	15
7.1	CAUTIONS.....	15
7.2	SLAVE ADDRESS	15
7.3	I ² C BUS PROTOCOL	15
7.3.1	<i>Write process.....</i>	<i>15</i>



7.3.2	Read process.....	16
8	DIMENSIONS	17

DAPU Confidential FOR Symmetron



1 Overview

INS5710A is an I²C bus interface real-time clock with low power consumption. It embeds a 32.768KHz XO. It supports calendar (year, month, day, hour, minute, second) function. The SOP8 package makes it suitable to be used in portable electronic devices.

2 Block Diagram

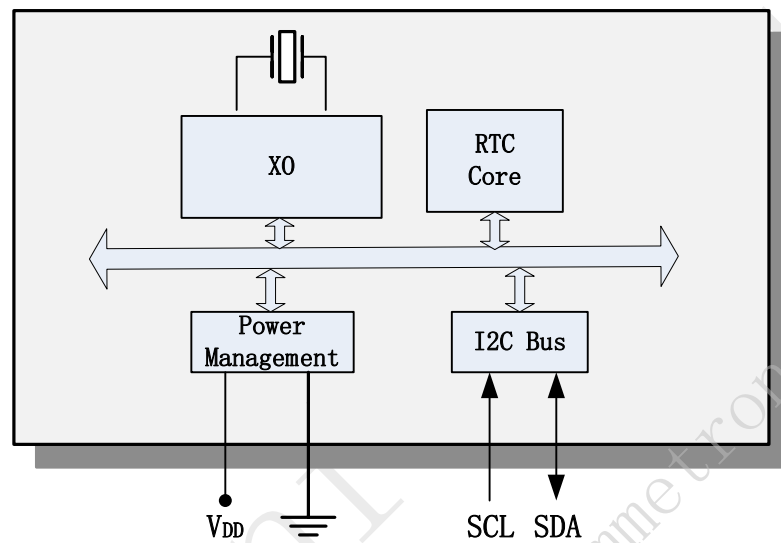

Figure 1. Block Diagram

3 Features

- Low current consumption: 1.2 uA (Typ.)
- High stability:
< 5±23ppm @ +25°C
- Communication Interface: I2C bus
- Power Supply Voltage: 1.6V ~ 5.0V
- Build-in XO: 32.768KHz
- Operation Temperature Range: -40°C ~ +85°C
- Build-in temperature sensor
- Leap years autocorrection
- Package: 4.9mm × 6.0mm × 1.6mm



4 Pin definition

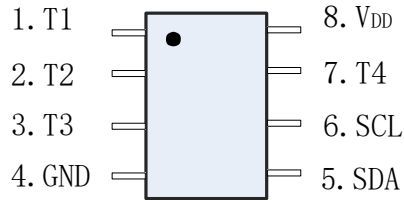

Table1. Pin Definition

Pin Number	Pin Name	I/O	Description
1	T1		Manufacturer test only. Ensure to be floating
2	T2		Manufacturer test only. Ensure to be floating
3	T3		Manufacturer test only. Ensure to be floating
4	GND	-	Ground
5	SDA	In/Out	I ² C data signal
6	SCL	In	I ² C clock signal
7	T4		Manufacturer test only. Ensure to be floating
8	V _{DD}	-	Power supply



5 Electrical Characteristics

5.1 Absolute Maximum Ratings

Table2. Absolute Maximum Ratings

Parameter	Symbol	Value			Unit	Notes
		Min.	Typ.	Max.		
Power Supply Voltage	V _{DD}	-0.3		5.5	V	
Input Voltage	V _{IN}	GND-0.3		5.5	V	SCL, SDA input
Output Voltage	V _{OUT2}	GND-0.3		5.5	V	SDA output
Storage temperature	T _{STG}	-55		125	°C	

5.2 Recommended Operating Conditions

Table3. Recommended Operating Conditions

Parameter	Symbol	Value			Unit	Notes
		Min.	Typ.	Max.		
Power Supply Voltage (normal mode)	V _{DD}	2.5	3.0	5.0	V	
Power Supply Voltage (Time keeping) (Note 1)	V _{DD}	1.6	3.0	5.0	V	
Operation temperature	T _{OPR}	-40	25	85	°C	

Note 1: V_{DD} need to be supplied with more than 2.5V at least for the oscillation to stabilize (oscillation start time t_{STA}).

5.3 Frequency Characteristics

Table4. Frequency Characteristics

Parameter	Symbol	Value			Unit	Notes
		Min.	Typ.	Max.		
Frequency stability	$\Delta f_1/f$	5±23			ppm	V _{DD} =3.0V; @+25°C
	$\Delta f_2/f$	-120		+10	ppm	V _{DD} =3.0V; -20°C ~ +70°C; Reference frequency @ +25°C
Oscillation start time	t _{STA}			1	s	@25°C
Year Aging	f _a			±3	ppm	
Temperature Sensor Accuracy	T _{emp}			±5	°C	V _{DD} =3.0V



5.4 DC Characteristics

Table5. DC Characteristics

Parameter	Symbol	Value			Unit	Notes	
		Min.	Typ.	Max.			
Average Current consumption1	I _{DD1}	0.91		5.1	uA	V _{DD} =5.0V	f _{SCL} =0Hz, /INT = V _{DD} ; Compensation interval 2s
Average Current consumption2	I _{DD2}	0.6	1.2	4.9		V _{DD} =3.0V	
High-level input voltage	V _{IH}	0.8*V _{DD}		5.0	V	SCL, SDA pin	
Low-level input voltage	V _{IL}	GND-0.3		0.2*V _{DD}	V		
Low-level output	V _{OL1}	GND		GND+0.4	V	V _{DD} ≥3.0V, I _{OL} = 3mA	SDA pin
Input leakage current	I _{LK}	-0.5		0.5	uA	SDA, SCL pin, V _{IN} = V _{DD} or GND	
Output leakage current	I _{OZ}	-0.5		0.5	uA	SDA pin, V _{IN} = V _{DD} or GND	



5.5 AC Characteristics

Table6. AC Characteristics

V_{DD}=2.5V ~ 5.0V; Ta=-40°C ~ +85°C

Parameter	Symbol	Value			Unit
		Min.	Typ.	Max.	
SCL clock frequency	f _{SCL}			400	kHz
SCL low level time	t _{LOW}	1.3			us
SCL high level time	t _{HIGH}	0.6			us
Start condition setup time	t _{HD;STA}	0.6			us
Start condition hold time	t _{SU;STA}	0.6			us
Stop condition setup time	t _{SU;STO}	0.6			us
Bus idle time between start condition and stop condition	t _{RCV}	1.3			us
Data setup time	t _{SU;DAT}	100			ns
Data hold time	t _{HD;DAT}	0			ns
SCL, SDA rising time	t _r			0.4	us
SCL, SDA falling time	t _f			0.4	us

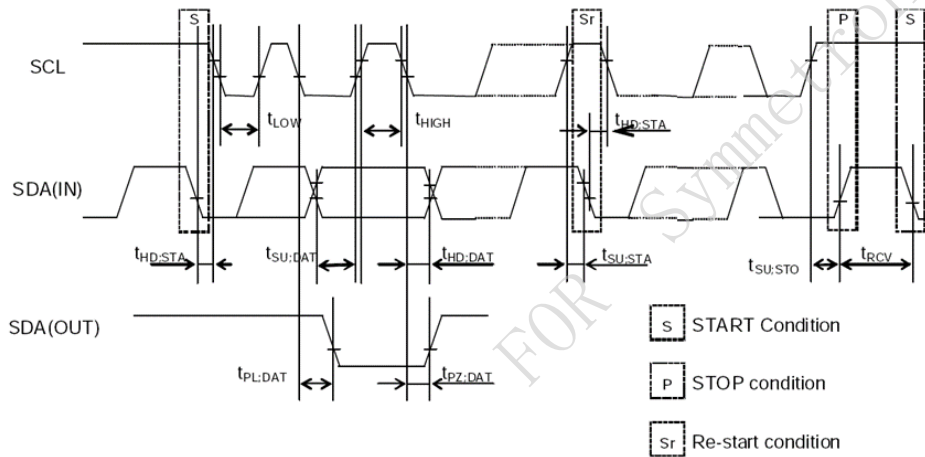

Figure 2. I²C bus Timing Chart



6 Registers

6.1 Register Lists

Address 0x00~0x0F: Basic Time and Calendar Registers

Address 0x10~0x1F: Extended Register Group 1

Address 0x20~30: Extended Register Group 2

Note: 0x10~16 and 0x00~06 with the same function, 0x1B~1F and 0x0B~0F with the same function

Table7. Basic Time and Calendar Registers

Address	Function	bit7	bit6	bit5	bit4	bit3	bit2	bit1	bit0	R/W
0x00	SEC	○	BCD code, Second tens place, 0-5			BCD code, Second ones place, 0-9				R/W
0x01	MIN	○	BCD code, Minute tens place, 0-5			BCD code, Minute ones place, 0-9				R/W
0x02	HOUR	○	○	BCD code, Hour tens place, 0-2		BCD code, Hour ones place, 0-9				R/W
0x03	WEEK	○	6	5	4	3	2	1	0	R/W
0x04	DAY	○	○	BCD code, Day tens place, 0-3		BCD code, Day ones place, 0-9				R/W
0x05	MONTH	○	○	○	BCD code, Month tens place, 0-1	BCD code, Month ones place, 0-9				R/W
0x06	YEAR	BCD code, Year tens place, 0-9				BCD code, Year ones place, 0-9				R/W
0x07	RAM	●	●	●	●	●	●	●	●	R/W
0x08	RSV	Reserved								R
0x09	RSV	Reserved								R
0x0A	RSV	Reserved								R
0x0B	RSV	Reserved								R
0x0C	RSV	Reserved								R
0x0D	Extension Register	TEST	Reserved			●	●	Reserved		R/W
0x0E	Flag Register	○	○	Reserved			○	VLF	Reserved	R/W
0x0F	Control Register	Reserved				○	○	RESET		R/W

Table8. Extended Register Group 1

Address	Function	bit7	bit6	bit5	bit4	bit3	bit2	bit1	bit0	R/W
0x10	SEC	○	BCD code, Second tens place, 0-5			BCD code, Second ones place, 0-9				R/W
0x11	MIN	○	BCD code, Minute tens place, 0-5			BCD code, Minute ones place, 0-9				R/W
0x12	HOUR	○	○	BCD code, Hour tens place, 0-2		BCD code, Hour ones place, 0-9				R/W
0x13	WEEK	○	6	5	4	3	2	1	0	R/W



Address	Function	bit7	bit6	bit5	bit4	bit3	bit2	bit1	bit0	R/W
0x14	DAY	○	○	BCD code, Day tens place, 0-3		BCD code, Day ones place, 0-9				R/W
0x15	MONTH	○	○	○	BCD code, Month tens place, 0-1	BCD code, Month ones place, 0-9				R/W
0x16	YEAR	BCD code, Year tens place, 0-9				BCD code, Year ones place, 0-9				R/W
0x17	TEMP	128	64	32	16	8	4	2	1	R
0x18	RSV	○	○	○	○	Reserved	●	●	●	R/W
0x19	Not use	○	○	○	○	○	○	○	○	R
0x1A	Not use	○	○	○	○	○	○	○	○	R
0x1B	RSV	Reserved								R/W
0x1C	RSV	Reserved								R/W
0x1D	Extension Register	TEST	Reserved			●	●	Reserved		R/W
0x1E	Flag Register	○	○	Reserved			○	VLF	Reserved	R/W
0x1F	Control Register	Reserved				○	○	RESET	R/W	

Table9. Extended Register Group2

Address	Function	bit7	bit6	bit5	bit4	bit3	bit2	bit1	bit0	R/W
0x20	Device ID	Vendor ID[3:0]				Ver[3:0]				R
0x21	Control Register 1	Reserved: Ensure to be 0x8				○	○	○	●	R/W
0x22-26	RSV	Reserved: Ensure to be 0x00								R
0x27	SubSEC	Reserved				SubSEC[3:0]				R
0x28-30	RSV	Reserved: Ensure to be 0x00								R/W

Note:

1, After power-up reset or in case VLF bit returns “1”, make sure to initialize all registers to default state before using the RTC. Ensure all inputs are in the required range and the defined values are set for the reserved bits in case the clock cannot work normally.

- ✓ During the initial power-up, below bits will be in the state as below:
 - Initial 0: TEST, CSEL[1], RESET.
 - Initial 1: VLF, CSEL[0].
- ✓ All other register values are undefined, so make sure to reset the module before using it.
- ✓ The bits marked with “○” can be read out “0” only after initializing.
- ✓ The bits marked with “●” are RAM bits which can be used to write or read any data.
- ✓ Only 0 can be written to VLF bits.
- ✓ Make sure “0” to be written for TEST bits which are used for testing only.
- ✓ Reserved bits must be set to the defined values accordingly.



6.2 Details of Registers

6.2.1 Clock counter registers

Address	Function	bit7	bit6	bit5	bit4	bit3	bit2	bit1	bit0	Default
0x00/10	SEC	○	BCD code, Second tens place, 0-5			BCD code, Second ones place, 0-9				0x25
0x01/11	MIN	○	BCD code, Minute tens place, 0-5			BCD code, Minute ones place, 0-9				0x36
0x02/12	HOUR	○	○	BCD code, Hour tens place, 0-2		BCD code, Hour ones place, 0-9				0x01

SEC: BCD format, Value: 0~59

MIN: BCD format, Value: 0~59

HOUR: BCD format, Value: 0~23

Address	Function	bit7	bit6	bit5	bit4	bit3	bit2	bit1	bit0	Default
0x03/13	WEEK	○	6	5	4	3	2	1	0	0x40

WEEK: Value 01h, 02h, 04h, 08h, 10h, 20h, 40h. Only one bit can be set to 1 each time, all others must be set to 0.

Table10. WEEK Register

WEEK	Data	bit7	bit6	bit5	bit4	bit3	bit2	bit1	bit0
Sunday	01h	0	0	0	0	0	0	0	1
Monday	02h	0	0	0	0	0	0	1	0
Tuesday	04h	0	0	0	0	0	1	0	0
Wednesday	08h	0	0	0	0	1	0	0	0
Thursday	10h	0	0	0	1	0	0	0	0
Friday	20h	0	0	1	0	0	0	0	0
Saturday	40h	0	1	0	0	0	0	0	0

Address	Function	bit7	bit6	bit5	bit4	bit3	bit2	bit1	bit0	Default
0x04/14	DAY	○	○	BCD code, Day tens place, 0-3		BCD code, Day ones place, 0-9				0x01

DAY: BCD format, the value range will be adjusted automatically according to the month setting and if a leap year or not .

Table11. DAY Register Value

Month	Day Value Range
1, 3, 5, 7, 8, 10, 12	1~31
4, 6, 9, 11	1~30
February in normal year	1~28
February in leap year	1~29



Address	Function	bit7	bit6	bit5	bit4	bit3	bit2	bit1	bit0	Default
0x05/15	MONTH	○	○	○	BCD code, Month tens place, 0-1	BCD code, Month ones place, 0-9				0x01
0x06/16	YEAR	BCD code, Year tens place, 0-9				BCD code, Year ones place, 0-9				0x00

MONTH: BCD format, Value1~12

YEAR: BCD format, Value0~99(2000~2099)

Example: 2020/01/01 Wednesday 21:18:36

Address	Function	bit7	bit6	bit5	bit4	bit3	bit2	bit1	bit0
0x00/10	SEC	○	0	1	1	0	1	1	0
0x01/11	MIN	○	0	0	1	1	0	0	0
0x02/12	HOUR	○	○	1	0	0	0	0	1
0x03/13	WEEK	○	0	0	0	1	0	0	0
0x04/14	DAY	○	○	0	0	0	0	0	1
0x05/15	MONTH	○	○	○	0	0	0	0	1
0x06/16	YEAR	0	0	1	0	0	0	0	0

6.2.2 Extension registers

Address	Function	bit7	bit6	bit5	bit4	bit3	bit2	bit1	bit0	Default
0x0D/1D	Extension Register	TEST	Reserved			•	•	Reserved		0x02

TEST: Test bit, must be set to “0”

6.2.3 Flag registers

Address	Function	bit7	bit6	bit5	bit4	bit3	bit2	bit1	bit0	Default
0x0E/1E	Flag Register	○	○	Reserved			○	VLF	Reserved	0x23

VLF: Voltage Low Flag bit. When supply voltage is lower than 1.6V, it will be set to “1” and keeps “1” until a “0” is written to it.

6.2.4 Control registers

Address	Function	bit7	bit6	bit5	bit4	bit3	bit2	bit1	bit0	Default	
0x0F/1F	Control Register	Reserved					○	○	RESET		0x40

RESET: Reset IC, prepared for the synchronized starting of time or timer.

6.2.5 Temperature register

Address	Function	bit7	bit6	bit5	bit4	bit3	bit2	bit1	bit0	Default
0x17	TEMP	128	64	32	16	8	4	2	1	0xa9



Read digital temperature data, $Temp [^{\circ}C] = (TEMP[7:0] * 2 - 187.19) / 3.218$.

6.2.6 RSV register

Address	Function	bit7	bit6	bit5	bit4	bit3	bit2	bit1	bit0	Default
0x18	Reserved	○	○	○	○	Reserved	●	●	●	0x00

Bit3 is the reserved bit, suggest being clear to '0'.

6.2.7 Device ID register

Address	Function	bit7	bit6	bit5	bit4	bit3	bit2	bit1	bit0	Default
0x20	Device ID	VendorID[3:0]				Ver[3:0]				0xd2

VendorID[3:0]: The fixed value is defined as VendorID[3:0]=1101b=Dh to represent DAPU.

Ver[3:0]: version of the IC

6.2.8 Control Register 1

Address	Function	bit7	bit6	bit5	bit4	bit3	bit2	bit1	bit0	Default
0x21	Control Register 1	Reserved: must be 0x8				○	○	○	●	0x80

6.2.9 Sub-second timer register

Address	Function	bit7	bit6	bit5	bit4	bit3	bit2	bit1	bit0	Default
0x27	SubSEC	Reserved				SubSEC[3:0]				0x00

SubSEC[3:0]: sub second bit, and unit is 1/16s.



7 I²C Bus Interface

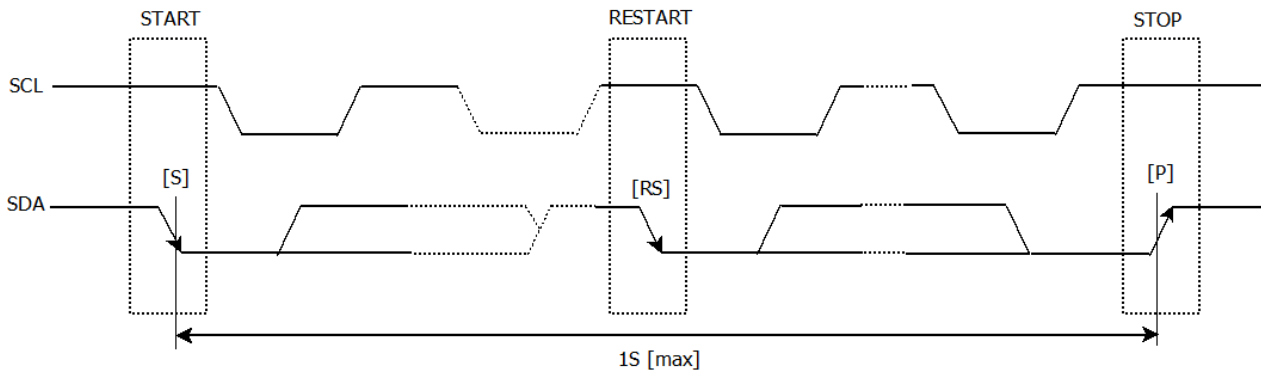

I²C bus supports bi-directional communications through a serial clock line SCL and a serial data line SDA. I²C bus device can be defined as “Master” and “Slave”. INS5710A can only be used as Slave.

7.1 Cautions

I²C bus includes START, RESTART, STOP conditions, the duration between START and STOP must be less than 1 second just in case the bus to be set to standby mode automatically. A new START condition must be transferred before restarting of any communications.

INS5710A I²C bus interface supports single byte read/write operations as well as multiple bytes incremental access. After 0x7F address, the next one will be 0x00.

7.2 Slave Address

Table12. I²C Bus Slave Address

Transfer data	Slave address							R/W
	bit7	bit6	bit5	bit4	bit3	bit2	bit1	bit0
65h (Read)	0	1	1	0	0	1	0	1 (Read)
64h (Write)								0 (Write)

INS5710A I²C bus Slave Address is [0110 010*].

7.3 I²C bus protocol

It is assumed CPU is master and INS5710A is slave in this section.

7.3.1 Write process

I²C bus includes an address auto-increment function, once the initial address has been specified, the



INS5710A increments (+1) the address automatically after each data is sent, then to write next data.

- (1) CPU sends start condition[S]
- (2) CPU sends INS5710A's slave address with R/W bit to set to write mode
- (3) CPU verifies ACK signal from INS5710A
- (4) CPU sends write address to INS5710A
- (5) CPU verifies ACK signal from INS5710A
- (6) CPU sends write data to the address specified at step (4)
- (7) CPU verifies ACK signal from INS5710A
- (8) Repeat (6) (7) if multiple bytes need to be written, address will be incremented automatically
- (9) CPU ends stop condition[P]

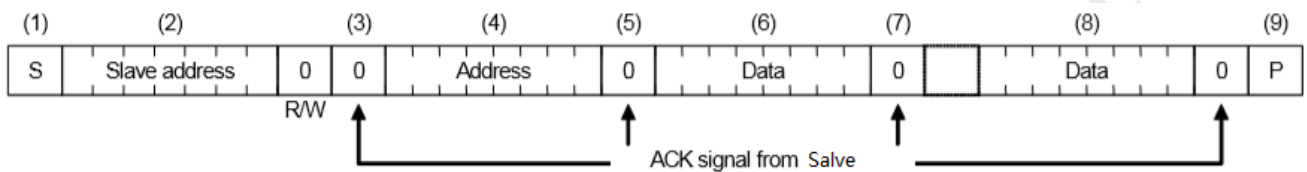

7.3.2 Read process

Writing the address to be read with write mode firstly, then reading the data with read mode.

- (1) CPU sends start condition[S]
- (2) CPU sends INS5710A's slave address with R/W bit to set to write mode
- (3) CPU verifies ACK signal from INS5710A
- (4) CPU sends address for reading from INS5710A
- (5) CPU verifies ACK signal from INS5710A
- (6) CPU sends RESTART condition [Sr]
- (7) CPU sends INS5710A's slave address with R/W bit to set to read mode
- (8) CPU verifies ACK signal from INS5710A
- (9) CPU reads data from the specified address in step (4)
- (10) CPU verifies ACK signal from INS5710A
- (11) Repeat (9) (10) if multiple bytes need to be read, address will be incremented automatically
- (12) CPU sends ACK signal for "1"
- (13) CPU sends stop condition[P]

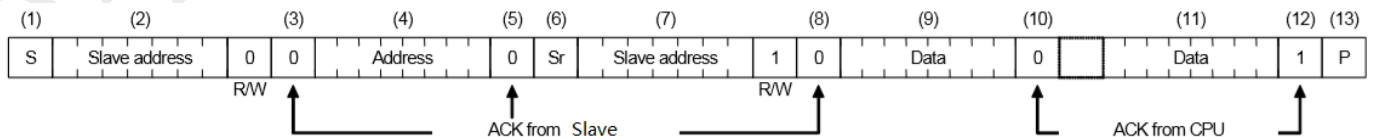



8 Dimensions

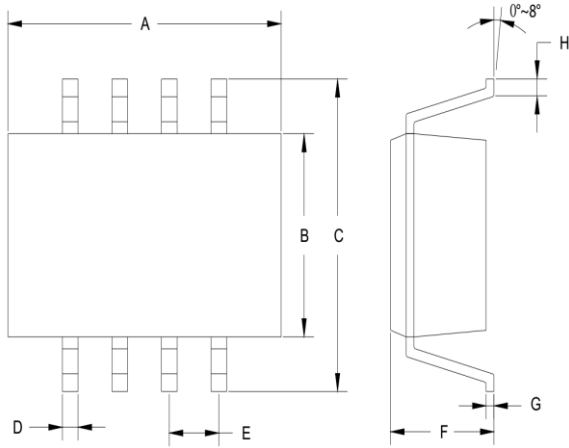

Dimension	Min.	Typ.	Max.
A	4.8	4.9	5.0
B	3.8	3.9	4.0
C	5.8	6.0	6.2
D	0.356	--	0.456
E	--	1.27	--
F	1.3	--	1.6
G	0.203	--	0.233
H	0.4	0.6	0.8

(Unit: mm)

Figure 3. Dimension