



Product Specification

AU OPTRONICS CORPORATION

AUO-General
G101EAN02.5

- () Preliminary Specifications
- (v) Final Specifications

Module	10.1 Inch Color TFT-LCD
Model Name	G101EAN02.5

Customer	Date
Checked & Approved by	

Approved by	Date
<u>Grace Hung</u>	<u>2020/10/21</u>
Prepared by	
<u>Jon Tseng</u>	<u>2020/10/21</u>
General Display Business Unit/ AU Optronics corporation	



Contents

1. Operating Precautions	4
2. General Description	5
2.1 Display Characteristics	5
2.2 Optical Characteristics	6
3. Functional Block Diagram	9
4. Absolute Maximum Ratings	10
4.1 Absolute Ratings of TFT LCD Module.....	10
4.2 Absolute Ratings of Environment.....	10
5. Electrical Characteristics	11
5.1 TFT LCD Module	11
5.2 Backlight Unit.....	14
6. Signal Characteristic	15
6.1 Pixel Format Image.....	15
6.2 Signal Description	16
6.3 Interface Timing	18
7. Reliability Test Criteria	20
8. Mechanical Characteristics	21
8.1 Outline Dimension (Front View)	21
8.2 Outline Dimension (Rear View).....	22
9. Label and Packaging	23
9.1 Shipping Label (on the rear side of TFT-LCD display)	23
9.2 Carton/Pallet Package	23
10 Safety	24
10.1 Sharp Edge Requirements.....	24
10.2 Materials	24
10.3 Capacitors.....	24
10.4 National Test Lab Requirement.....	24



Record of Revision

Version and Date	Page	Old description	New Description																												
0.0 2019/11/13	All	First draft specification	--																												
1.0 2020/10/21	4	Remove item 17	--																												
	5	LED power max TBD W	LED power max 2.916 W																												
	5	G101EAN02.1 is a Color Active Matrix Liquid Crystal Display	G101EAN02.5 is a Color Active Matrix Liquid Crystal Display																												
	6	NTSC 50%	NTSC 45%																												
	14	<table border="1"> <tr> <td>I_{LED}</td> <td>Input Current</td> <td>---</td> <td>188.75</td> <td>204.19</td> <td>[mA]</td> <td>100% Brightness (VLED = 12V)</td> </tr> <tr> <td>P_{LED}</td> <td>Power Consumption</td> <td>---</td> <td>TBD</td> <td>TBD</td> <td>[Watt]</td> <td>100% Brightness (VLED = 12V)</td> </tr> </table>	I_{LED}	Input Current	---	188.75	204.19	[mA]	100% Brightness (VLED = 12V)	P_{LED}	Power Consumption	---	TBD	TBD	[Watt]	100% Brightness (VLED = 12V)	<table border="1"> <tr> <td>I_{LED}</td> <td>Input Current</td> <td>---</td> <td>218</td> <td>243</td> <td>[mA]</td> <td>100% Brightness (VLED = 12V)</td> </tr> <tr> <td>P_{LED}</td> <td>Power Consumption</td> <td>---</td> <td>2.616</td> <td>2.916</td> <td>[Watt]</td> <td>100% Brightness (VLED = 12V)</td> </tr> </table>	I_{LED}	Input Current	---	218	243	[mA]	100% Brightness (VLED = 12V)	P_{LED}	Power Consumption	---	2.616	2.916	[Watt]	100% Brightness (VLED = 12V)
	I_{LED}	Input Current	---	188.75	204.19	[mA]	100% Brightness (VLED = 12V)																								
	P_{LED}	Power Consumption	---	TBD	TBD	[Watt]	100% Brightness (VLED = 12V)																								
	I_{LED}	Input Current	---	218	243	[mA]	100% Brightness (VLED = 12V)																								
P_{LED}	Power Consumption	---	2.616	2.916	[Watt]	100% Brightness (VLED = 12V)																									
14	<table border="1"> <tr> <td>Operation Life</td> <td>---</td> <td>20,000</td> <td>30,000</td> <td>---</td> <td>Hrs</td> </tr> </table>	Operation Life	---	20,000	30,000	---	Hrs	<table border="1"> <tr> <td>Operation Life</td> <td>---</td> <td>20,000</td> <td>---</td> <td>---</td> <td>Hrs</td> </tr> </table>	Operation Life	---	20,000	---	---	Hrs																	
Operation Life	---	20,000	30,000	---	Hrs																										
Operation Life	---	20,000	---	---	Hrs																										
14	Note 3: If G101EAN02.1 module	Note 3: If G101EAN02.5 module																													
23	Shipping label G101EAN02.1	Shipping label G101EAN02.5																													
23	入庫堆棧層數：5層	Box stacked 5 layers																													

AUO Confidential for Promotional Use Only



1. Operating Precautions

- 1) Since front polarizer is easily damaged, please be cautious and not to scratch it.
- 2) Be sure to turn off power supply when inserting or disconnecting from input connector.
- 3) Wipe off water drop immediately. Long contact with water may cause discoloration or spots.
- 4) When the panel surface is soiled, wipe it with absorbent cotton or soft cloth.
- 5) Since the panel is made of glass, it may be broken or cracked if dropped or bumped on hard surface.
- 6) To avoid ESD (Electro Static Discharge) damage, be sure to ground yourself before handling TFT-LCD Module.
- 7) Do not open nor modify the module assembly.
- 8) Do not press the reflector sheet at the back of the module to any direction.
- 9) In case if a module has to be put back into the packing container slot after it was taken out from the container, do not press the center of the LED light bar edge. Instead, press at the far ends of the LED light bar edge softly. Otherwise the TFT Module may be damaged.
- 10) At the insertion or removal of the Signal Interface Connector, be sure not to rotate nor tilt the Interface Connector of the TFT Module.
- 11) TFT-LCD Module is not allowed to be twisted & bent even force is added on module in a very short time. Please design your display product well to avoid external force applying to module by end-user directly.
- 12) Small amount of materials having no flammability grade is used in the LCD module. The LCD module should be supplied by power complied with requirements of Limited Power Source (IEC60950 or UL1950), or be applied exemption.
- 13) Severe temperature condition may result in different luminance, response time and lamp ignition voltage.
- 14) Continuous operating TFT-LCD display under low temperature environment may accelerate lamp exhaustion and reduce luminance dramatically.
- 15) The data on this specification sheet is applicable when LCD module is placed in landscape position.
- 16) Continuous displaying fixed pattern may induce image sticking. It's recommended to use screen saver or shuffle content periodically if fixed pattern is displayed on the screen.

2. General Description

G101EAN02.5 is a Color Active Matrix Liquid Crystal Display composed of a TFT LCD panel and LED backlight system. The screen format is intended to support the 16:10 WXGA, 1200(H) x 800(V) screen and 16.7M colors (RGB 6-bits + Hi-FRC) with LED backlight driving circuit. All input signals are LVDS interface compatible.

2.1 Display Characteristics

The following items are characteristics summary under 25 °C condition:

Items	Unit	Specifications
Screen Diagonal	[inch]	10.1"
Active Area	[mm]	216.96(H) x 135.6(V)
Pixels H x V		1280 x 3(RGB) x 800
Pixel Pitch	[mm]	0.1695X 0.1695
Pixel Arrangement		R.G.B. Vertical Stripe
Display Mode		AHVA, Normally Black
Nominal Input Voltage VDD	[Volt]	3.3 (Typical)
Power Consumption	[Watt]	Logic Power : 1W(Max)@White pattern 3.3V input LED power max 2.916 W
Weight (Max.)	[Grams]	195
Physical Size (Max.)	[mm]	228.22 x 148.3x 4.8(max)
Electrical Interface		LVDS 1Port 8bit
Surface Treatment		HC
Support Color		16.7M colors (RGB 6-bit + Hi-FRC)
Temperature Range		
Operating	[°C]	-20 to +60 (Front and rear surface)
Storage (Non-Operating)	[°C]	-20 to +60
RoHS Compliance		RoHS Compliance

2.2 Optical Characteristics

The optical characteristics are measured under stable conditions at 25 °C (Room Temperature):

Item	Unit	Conditions	Min.	Typ.	Max.	Note
White Luminance	[cd/m ²]	I _{LED} = 25mA (center)	360	450	---	
Uniformity	%	5 points	70%		---	
Contrast Ratio			600	800	---	
Response Time	[msec]	Rising + Falling	---	29	38	
Viewing Angle	[degree]	Horizontal (Right)	80	89	---	
	[degree]	CR = 10 (Left)	80	89	---	
	[degree]	Vertical (Upper)	80	89	---	
	[degree]	CR = 10 (Lower)	80	89	---	
Color / Chromaticity Coordinates (CIE 1931)		Red x	0.532	0.582	0.632	
		Red y	0.295	0.345	0.395	
		Green x	0.29	0.34	0.39	
		Green y	0.522	0.572	0.622	
		Blue x	0.112	0.162	0.212	
		Blue y	0.077	0.127	0.177	
		White x	0.263	0.313	0.363	
		White y	0.279	0.329	0.379	
Color Gamut	%		---	45	---	

Note 1: Measurement method

Equipment Pattern Generator, Power Supply, Digital Voltmeter, Luminance meter (SR_3 or equivalent)

Aperture Field angle 2° with 50cm measuring distance

Test Point Follow Note 2 position

Environment < 1 lux

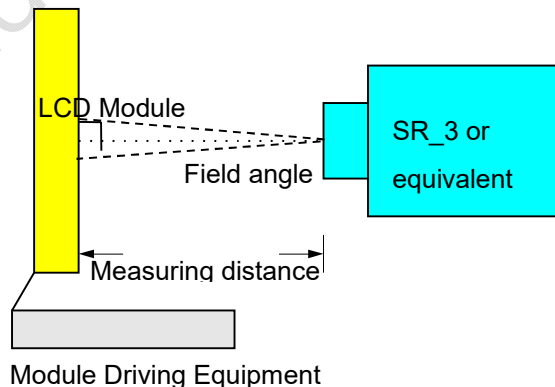

Note 2: Definition of 5 points position

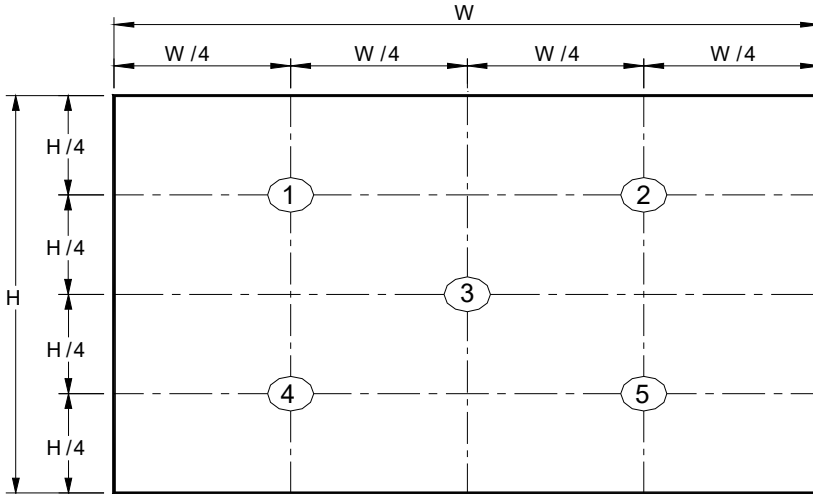

Note 3: The luminance uniformity of 5 points is defined by dividing the minimum luminance values by the maximum test point luminance

$$\delta_{w5} = \frac{\text{Minimum Brightness of five points}}{\text{Maximum Brightness of five points}}$$

Note 4: Definition of contrast ratio (CR):

$$\text{Contrast ratio (CR)} = \frac{\text{Brightness on the "White" state}}{\text{Brightness on the "Black" state}}$$

Note 5: Definition of response time:

The output signals of photo detector are measured when the input signals are changed from "White" to "Black" (falling time) and from "Black" to "White" (rising time), respectively. The response time interval is between 10% and 90% of amplitudes. Please refer to the figure as below.

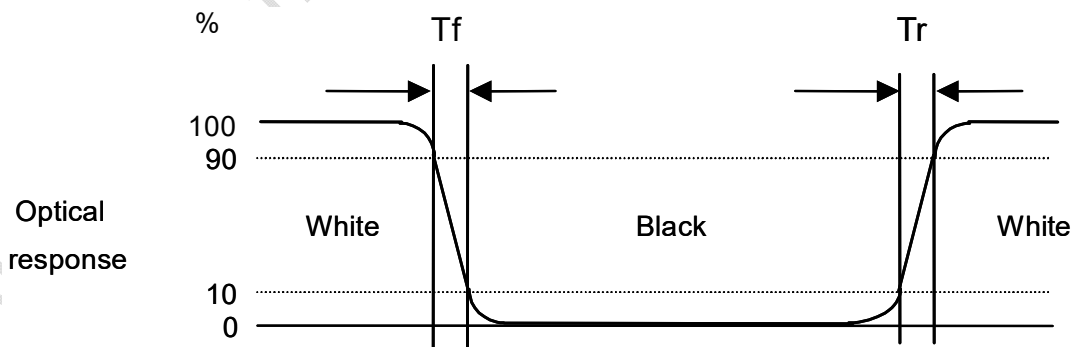

Note 6: Definition of viewing angle

Viewing angle is the measurement of contrast ratio ≥ 10 , at the screen center, over a 180° horizontal and 180° vertical range (off-normal viewing angles). The 180° viewing angle range is broken down as below: 90° (θ) horizontal left and right, and 90° (Φ) vertical high (up) and low (down). The measurement direction is typically perpendicular to the display surface with the screen rotated to its center to develop the desired measurement viewing angle.

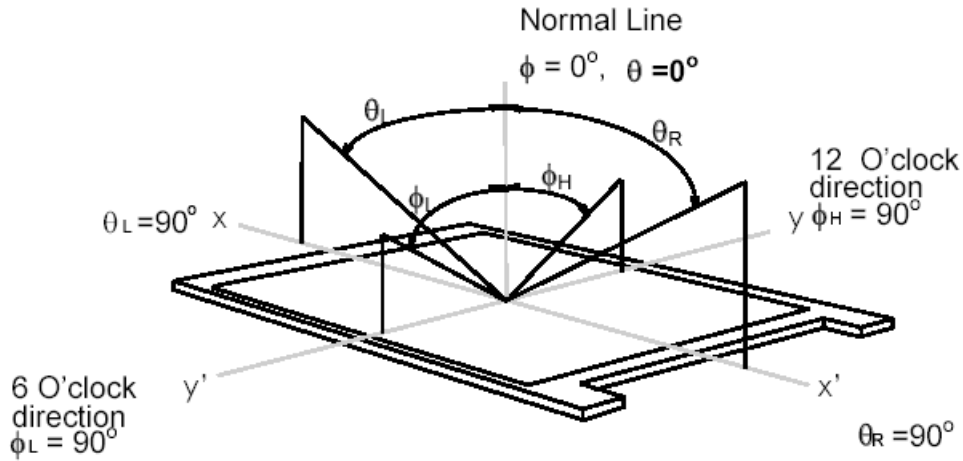

3. Functional Block Diagram

The following diagram shows the functional block of the 10.1 inch color TFT/LCD module:

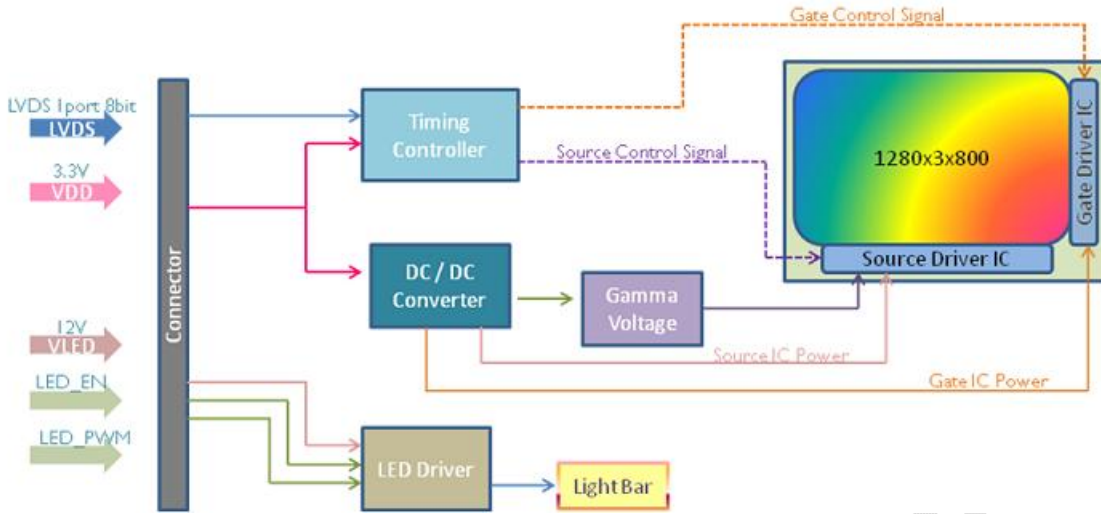

AUO Confidential for Promote use only



4. Absolute Maximum Ratings

4.1 Absolute Ratings of TFT LCD Module

Item	Symbol	Min	Max	Unit
Logic/LCD drive Voltage	VDD	-0.3	3.6	[Volt]
LCD Input Signal Voltage	V _{SIGNAL}	-0.3	3.6	[Volt]

4.2 Absolute Ratings of Environment

Item	Symbol	Min	Max	Unit
Operating Temperature	TOP	-20	+60	[°C]
Humidity	HOP	5	90	[%RH]
Storage Temperature	TST	-20	+60	[°C]
Storage Humidity	HST	5	90	[%RH]

Note 1: At Ta (25°C)

Note 2: Permanent damage to the device may occur if exceed maximum values

Note 3: Maximum wet-bulb temperature is less than 39 oC and no condensation

Note 4: Operating temperature means “Front and rear surface” of panel

5. Electrical Characteristics

5.1 TFT LCD Module

5.1.1 Power Specification

The power specification are measured under 25°C and frame frequency under 60Hz

Symbol	Parameter	Min	Typ	Max	Units	Remark
VDD	Logic/LCD Drive Voltage	3.0	3.3	3.6	[Volt]	
IDD	VDD Current	-	278.7	303	[mA]	All White Pattern (VDD=3.3V, at 59.9Hz)
Irush	LCD Inrush Current	-	-	1500	[mA]	Note 1
PDD	VDD Power	-	0.92	1	[Watt]	All White Pattern (VDD=3.3V, at 59.9Hz)
VDDrp	Allowable Logic/LCD Drive Ripple Voltage	-	-	100	[mV] p-p	All White Pattern (VDD=3.3V, at 59.9Hz)

Note 1 : Maximum Measurement Condition : White Pattern at 3.3V driving voltage. ($P_{max}=V_{3.3} \times I_{white}$)

Note 2: Measure Condition

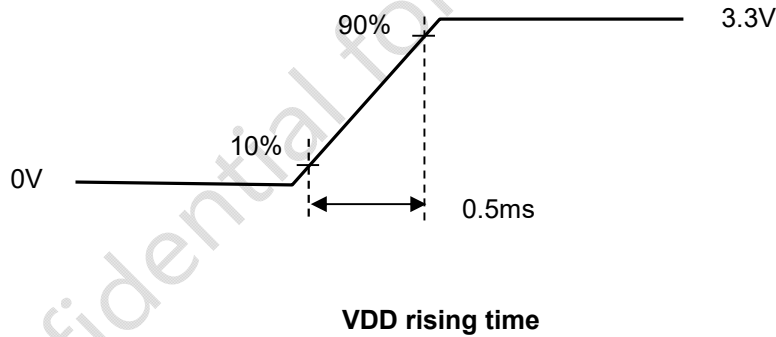

5.1.2 Signal Electrical Characteristics

Input signals shall be low or Hi-Z state when VDD is off.

Symbol	Item	Min.	Typ.	Max.	Unit	Remark
VTH	Differential Input High Threshold	-	-	100	[mV]	VCM=1.2V
VTL	Differential Input Low Threshold	-100	-	-	[mV]	VCM=1.2V
VID	Input Differential Voltage	100		600	[mV]	
VICM	Differential Input Common Mode Voltage	1.0	1.2	1.5	[V]	VTH/VTL=±100mV

Note: LVDS Signal Waveform.

$V_P - V_N = |VID| > V_{TH} = \text{"High"}$
 $V_P - V_N = -|VID| < V_{TL} = \text{"Low"}$

Single-end Signal

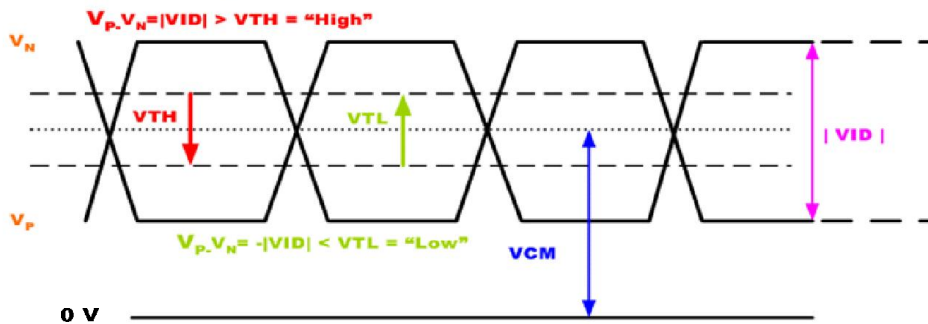

Differential Signal

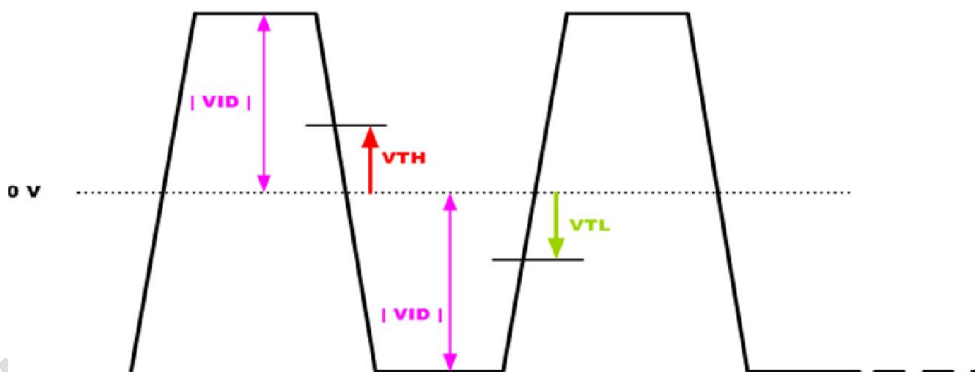

5.1.3 Power ON/OFF Sequence

VDD power and backlight on/off sequence is as below. Interface signals are also shown in the chart. Signals from any system shall be Hi-Z state or low level when VDD is off.

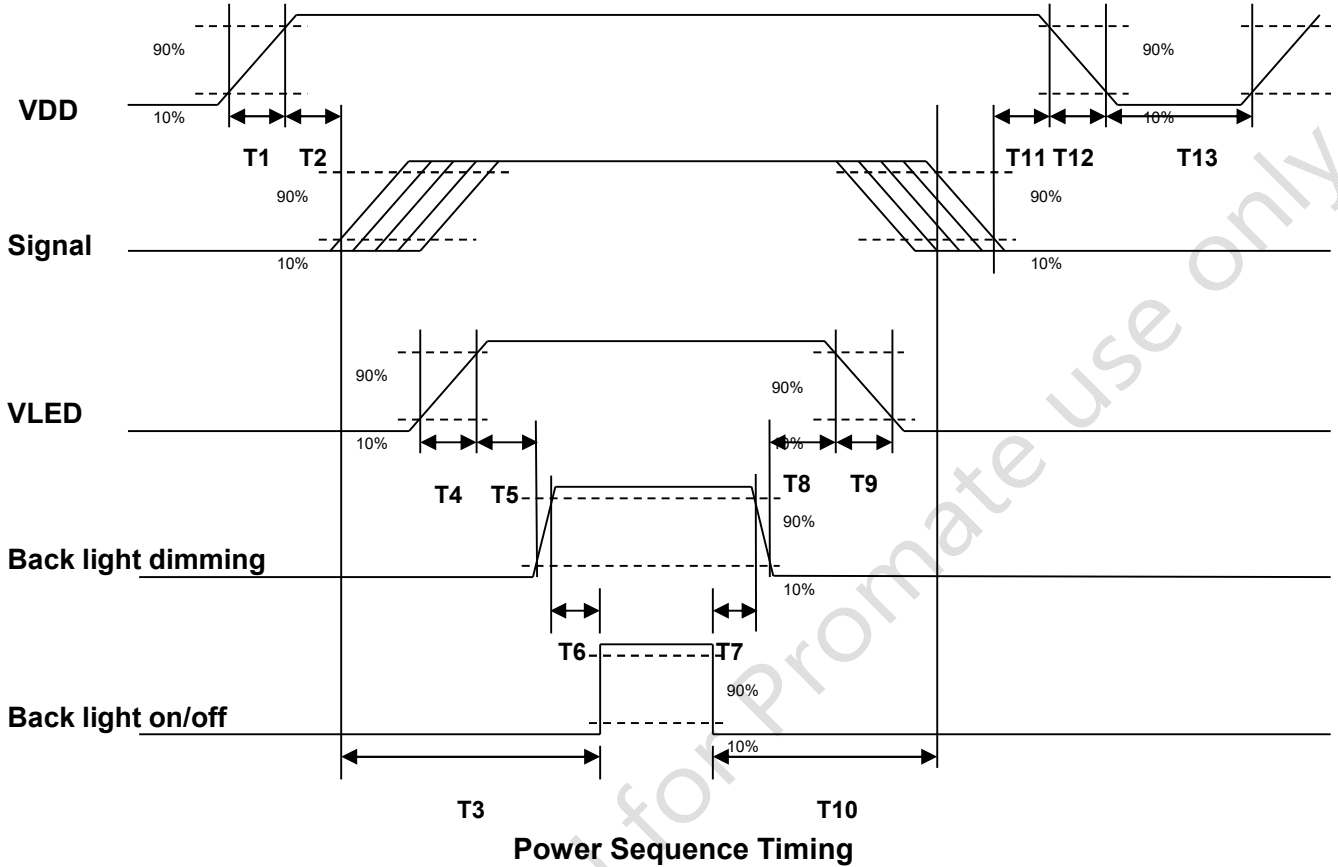

Parameter	Value			Unit
	Min.	Typ.	Max.	
T1	0.5	-	10	[ms]
T2	50	60	70	[ms]
T3	200	-	-	[ms]
T4	0.5	-	10	[ms]
T5	10	-	-	[ms]
T6	10	-	-	[ms]
T7	0	-	-	[ms]
T8	10	-	-	[ms]
T9	-	-	10	[ms]
T10	110	-	-	[ms]
T11	0	16	50	[ms]
T12	-	-	10	[ms]
T13	1000	-	-	[ms]

The above on/off sequence should be applied to avoid abnormal function in the display. Please make sure to turn off the power when you plug the cable into the input connector or pull the cable out of the connector.

5.2 Backlight Unit

5.2.1 Parameter guideline for LED

Following characteristics are measured under a stable condition using an inverter at 25°C (Room Temperature):

Symbol	Parameter	Min.	Typ.	Max.	Unit	Remark
VLED	Input Voltage	10.8	12	13.2	[Volt]	
I _{VLED}	Input Current	---	218	243	[mA]	100% Brightness (VLED = 12V)
P _{VLED}	Power Consumption	---	2.616	2.916	[Watt]	100% Brightness (VLED = 12V)
I _F	LED Forward Current	---	25	---	[mA]	Ta = 25°C
VEN	LED Enable Input High Level	2.3	-	5.5	[Volt]	
	LED Enable Input Low Level	-	-	0.3	[Volt]	
VPWM	PWM Logic Input High Level	2.3	-	5.5	[Volt]	
	PWM Logic Input Low Level	-	-	0.3	[Volt]	
PWM Input Frequency	FPWM	200	-	20K	Hz	
PWM Duty Ratio	Duty	10		100	%	
Operation Life	---	20,000	---	---	Hrs	(Ta=25°C), Note 2 IF=25mA

Note 1: Ta means ambient temperature of TFT-LCD module.

Note 2: VLED, I_{VLED}, P_{VLED} are defined for LED backlight.(100% duty of PWM dimming)

Note 3: If G101EAN02.5 module is driven by high current or at high ambient temperature & humidity condition. The operating life will be reduced.

Note 4: Operating life means brightness goes down to 50% initial brightness. Minimum operating life time is estimated data.

6. Signal Characteristic

6.1 Pixel Format Image

Following figure shows the relationship between input signal and LCD pixel format.

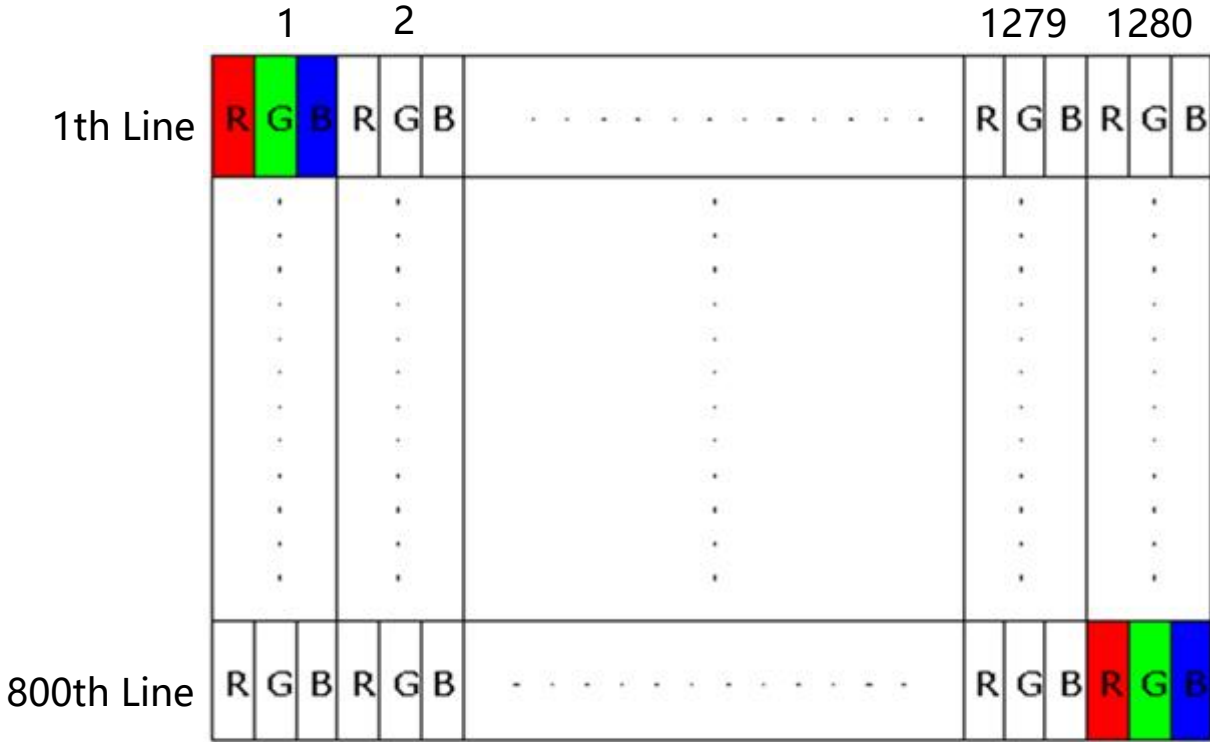

AUO Confidential

6.2 Signal Description

The following figures show the image seen from the front view. The arrow indicates the direction of scan.



6.2.1 Pin Assignment

LVDS is a differential signal technology for LCD interface and high speed data transfer device.

PIN NO	Symbol	Function
1	GND	Ground
2	VDD	LCD Power Supply +3.3V
3	VDD	LCD Power Supply +3.3V
4	VDD	LCD Power Supply +3.3V
5	NC	AUO Self Test Pin
6	NC	AUO Self Test Pin
7	NC	AUO Self Test Pin
8	Rxin0-	-LVDS differential data input
9	Rxin0+	+LVDS differential data input
10	GND	Ground
11	Rxin1-	-LVDS differential data input
12	Rxin1+	+LVDS differential data input
13	GND	Ground
14	Rxin2-	-LVDS differential data input
15	Rxin2+	+LVDS differential data input
16	GND	Ground
17	ClkIN-	-LVDS differential clock input
18	ClkIN+	+LVDS differential clock input
19	GND	Ground
20	Rxin3-	-LVDS differential data input



21	Rxin3+	+LVDS differential data input
22	GND	Ground
23	NC	No connect
24	NC	No connect
25	GND	Ground
26	NC	No connect
27	NC	No connect
28	GND	Ground
29	NC	No connect
30	NC	No connect
31	BL_GND	Ground for backlight
32	BL_GND	Ground for backlight
33	BL_GND	Ground for backlight
34	NC	No connect
35	LED_PWM	PWM Dimming
36	LED_EN	LED ON/OFF
37	NC	No connect
38	VLED	LED Power Supply +12V
39	VLED	LED Power Supply +12V
40	VLED	LED Power Supply +12V

6.2.2 LVDS Connector

Connector Name / Designation	Signal Connector
Manufacturer	IPEX or compatible
Connector Model Number	IPEX 20765-040E-11A or compatible
Adaptable Plug	IPEX 20453-040T-01 or compatible

6.3 Interface Timing

6.3.1 Timing Characteristics

Signal	Symbol	Min.	Typ.	Max.	Unit
Clock Frequency	1/ TClock	68.9	71.1	74.5	MHz
Vertical Section	Period	TV	815	840	TLine
	Active	TVD	800		
	Blanking	TVB	15	23	
Horizontal Section	Period	TH	1410	1480	TClock
	Active	THD	1280		
	Blanking	THB	130	160	
Frame Rate	F	---	59.99	---	Hz

Note : DE mode.

6.3.2 Input Timing Diagram

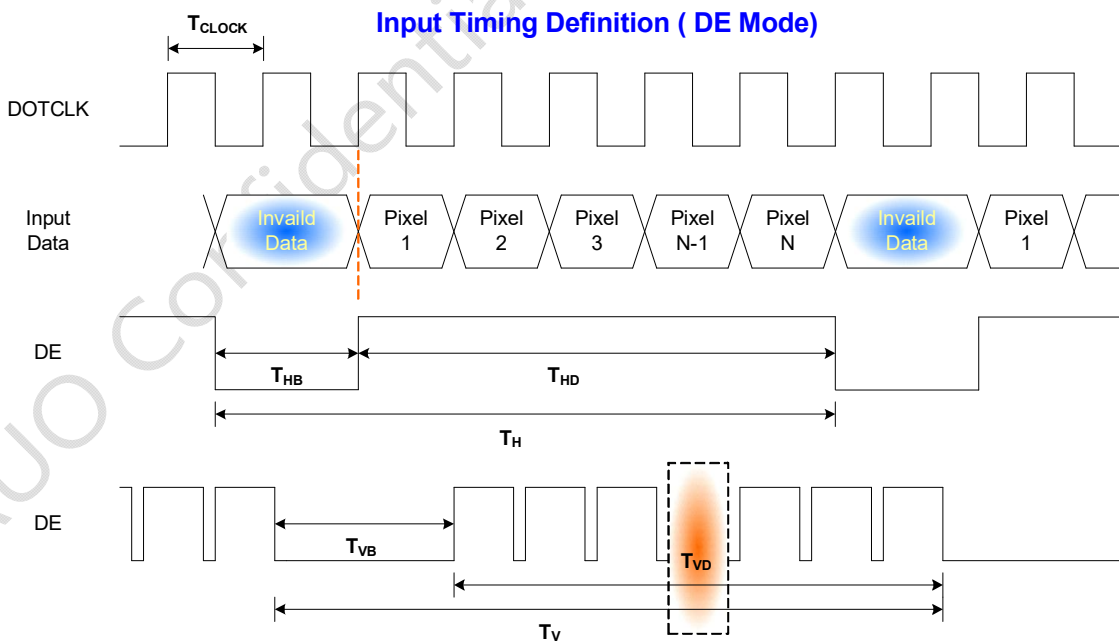

6.3.3 The Input Data Format

8 bits LVDS Input (VESA Format)

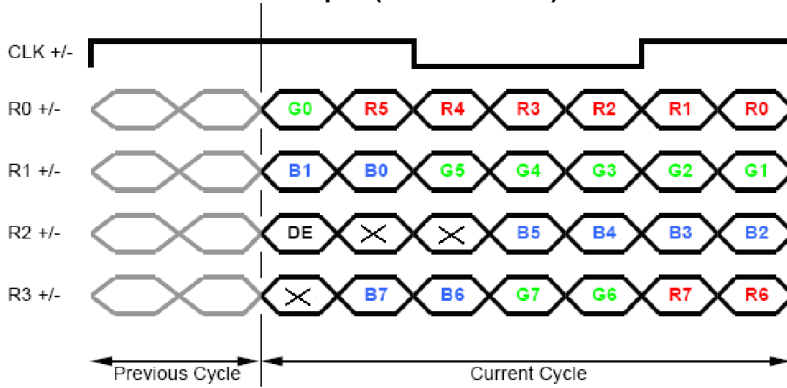

Signal Name	Description	
R7 R6 R5 R4 R3 R2 R1 R0	Red Data 7 (MSB) Red Data 6 Red Data 5 Red Data 4 Red Data 3 Red Data 2 Red Data 1 Red Data 0 (LSB)	Red-pixel Data For 8Bits LVDS input MSB: R7 ; LSB: R0
G7 G6 G5 G4 G3 G2 G1 G0	Green Data 7 (MSB) Green Data 6 Green Data 5 Green Data 4 Green Data 3 Green Data 2 Green Data 1 Green Data 0 (LSB)	Green-pixel Data For 8Bits LVDS input MSB: R7 ; LSB: R0
B7 B6 B5 B4 B3 B2 B1 B0	Blue Data 7 (MSB) Blue Data 6 Blue Data 5 Blue Data 4 Blue Data 3 Blue Data 2 Blue Data 1 Blue Data 0 (LSB)	Blue-pixel Data For 8Bits LVDS input MSB: R7 ; LSB: R0
RxCLKIN	Data Clock	The signal is used to strobe the pixel data and DE signals. All pixel data shall be valid at the falling edge when the DE signal is high.
DE	Display Timing	This signal is strobed at the falling edge of RxCLKIN. When the signal is high, the pixel data shall be valid to be displayed.

Note: Output signals from any system shall be low or High-impedance state when VDD is off.

7. Reliability Test Criteria

Items	Required Condition	Note
Temperature Humidity Bias	40 °C /90%,300Hr	
High Temperature Operation	60 °C, 300Hr (center point of panel surface)	
Low Temperature Operation	-20 °C, 300Hr	
Hot Storage	60 °C, 300Hr	
Cold Storage	-20 °C, 300Hr	
Thermal Shock Test	-20 °C /30 min , 60 °C /30 min , 100cycles	
On/off test	On/10 sec, Off/10 sec, 30,000 cycles	
ESD	Contact : ± 8KV/ operation, Class B Air : ± 15KV / operation, Class B	Note 1
Shock test	50G,20ms,Half-sine wave,(±X, ±Y, ±Z), non-operation	
Vibration test	1.5G, (10~200Hz, random), 30 mins / axis (X, Y, Z),non-operation	

Note1: According to EN61000-4-2 , ESD class B: Some performance degradation allowed. No data lost
. Self-recoverable. No hardware failures.

Note2:

- Water condensation is not allowed for each test items.
- Each test is done by new TFT-LCD module. Don't use the same TFT-LCD module repeatedly for reliability test.
- The reliability test is performed only to examine the TFT-LCD module capability.
- To inspect TFT-LCD module after reliability test, please store it at room temperature and room humidity for 24 hours at least in advance.



8. Mechanical Characteristics

8.1 Outline Dimension (Front View)

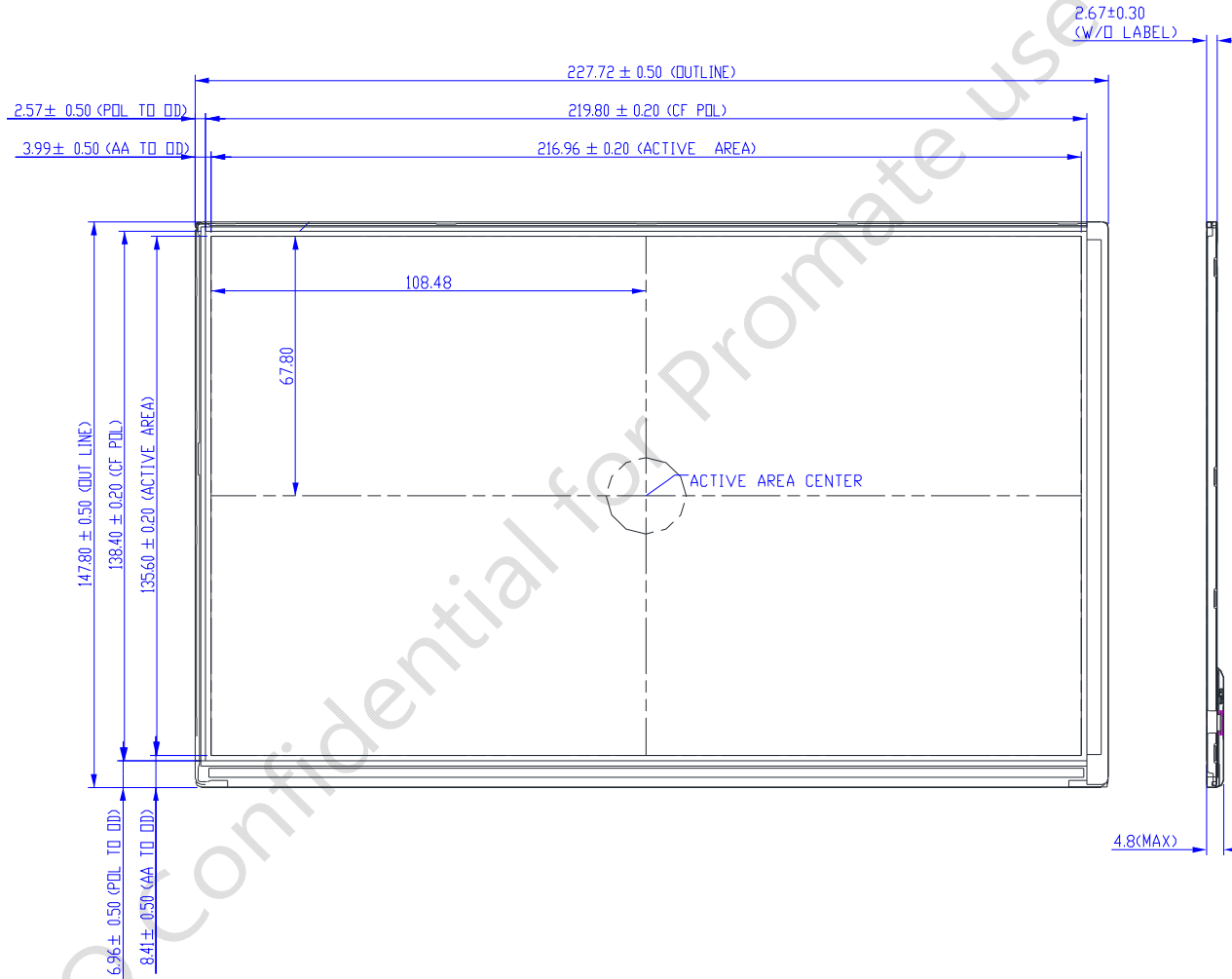

8.2 Outline Dimension (Rear View)

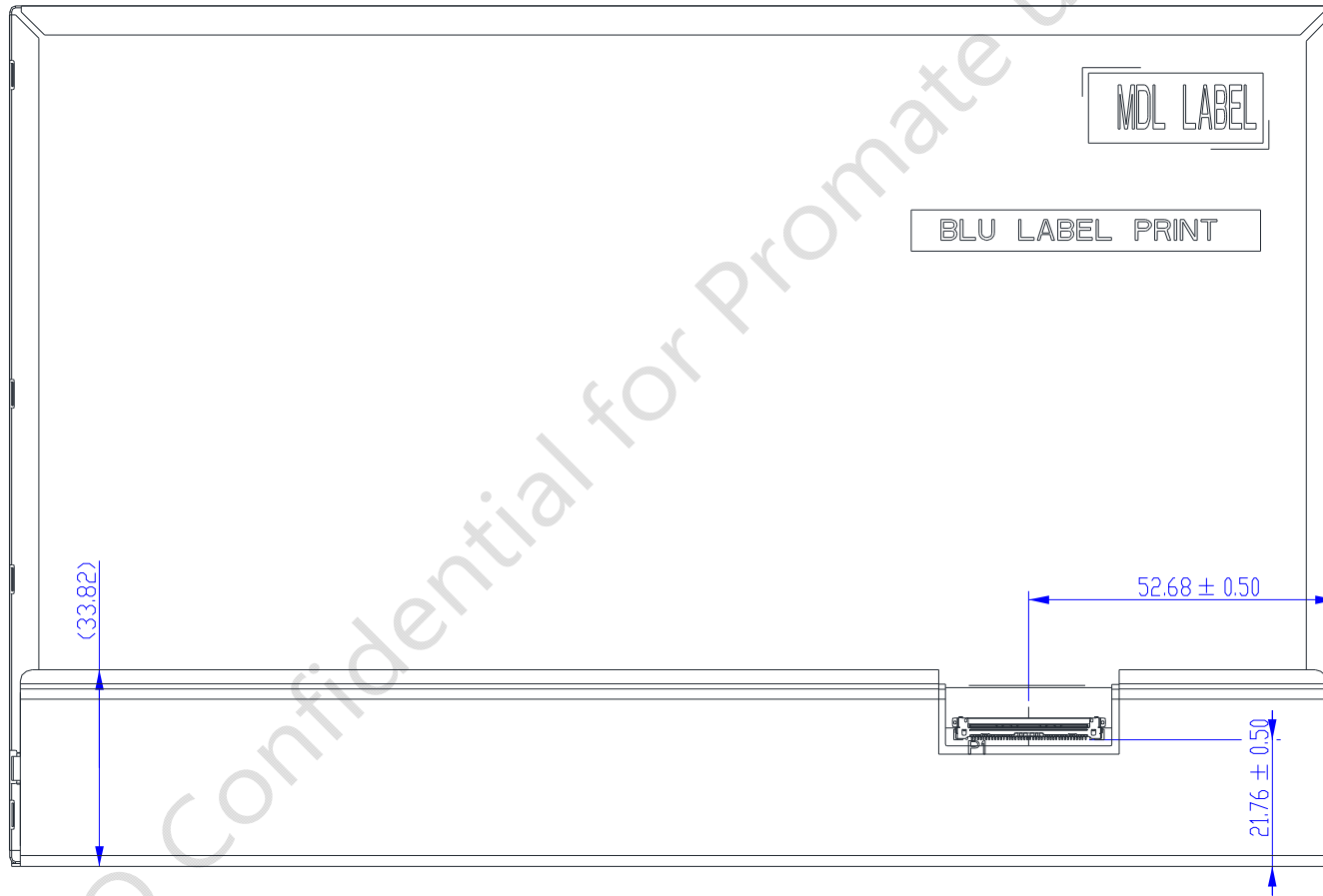

AUO Confidential for Promate use only

9. Label and Packaging

9.1 Shipping Label (on the rear side of TFT-LCD display)



9.2 Carton/Pallet Package

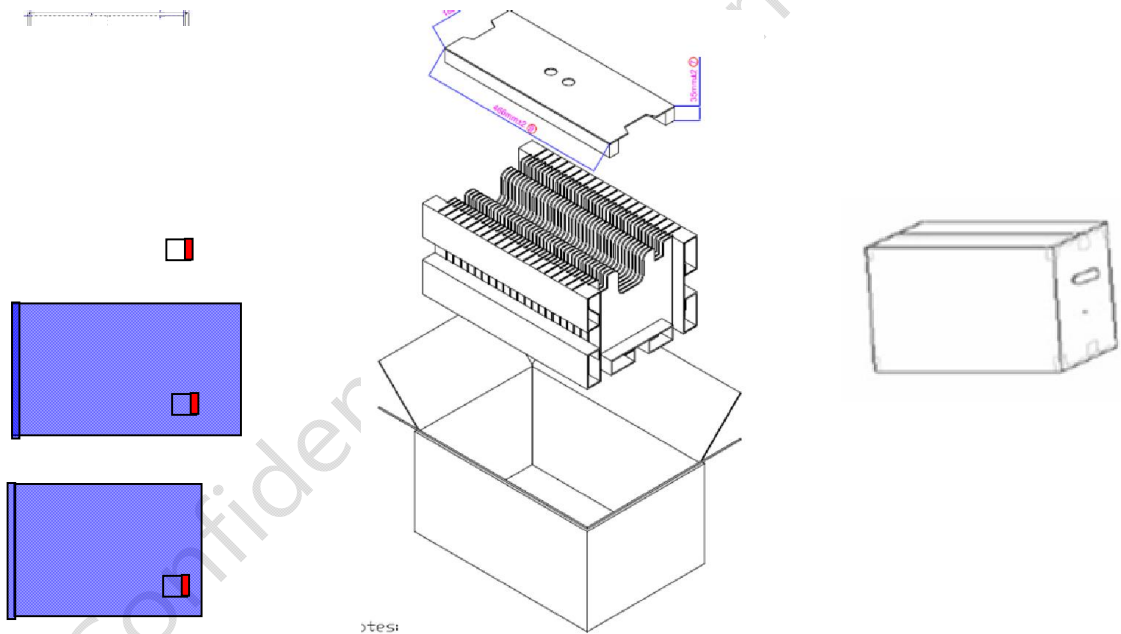

Max capacity: 40 TFT-LCD module per carton

Outside dimension of carton: 484*328*257mm

Pallet size: 1150 mm * 980 mm * 132mm

Box stacked 5 layers

Box stacked

Module by air: (2 *3) *5 layers, one pallet put 30 boxes, total 1200pcs module

Module by sea: (2 *3) *5 layers + (2 *3) *2 layers, two pallet put 42 boxes, total 1680pcs module

Module by sea_HQ: (2 *3) *5 layers+(2 *3) *3 layers, two pallet put 48 boxes, total 1920pcs module



10 Safety

10.1 Sharp Edge Requirements

There will be no sharp edges or comers on the display assembly that could cause injury.

10.2 Materials

10.2.1 Toxicity

There will be no carcinogenic materials used anywhere in the display module. If toxic materials are used, they will be reviewed and approved by the responsible AUO toxicologist.

10.2.2 Flammability

All components including electrical components that do not meet the flammability grade UL94-V1 in the module will complete the flammability rating exception approval process.

The printed circuit board will be made from material rated 94-V1 or better. The actual UL flammability rating will be printed on the printed circuit board.

10.3 Capacitors

If any polarized capacitors are used in the display assembly, provisions will be made to keep them from being inserted backwards.

10.4 National Test Lab Requirement

The display module will satisfy all requirements for compliance to:

UL 60950-1 second edition

U.S.A. Information Technology Equipment