

TENTATIVE

All information in this technical data sheet is tentative
and subject to change without notice.

Preliminary

3.5" QVGA

TECHNICAL SPECIFICATION

COMPANY PROPRIETARY
NOT TO BE REPRODUCED OR DISCLOSED WITHOUT SPECIFIC
WRITTEN PERMISSION OF MITSUBISHI ELECTRIC CORPORATION
(THIS IS A RED INK STAMP)

AC035QG01--T1

MITSUBISHI ELECTRIC CORPORATION

Date: May.30,'16

CONTENTS

No.	Item	Page
--	COVER	1
--	CONTENTS	2
1	APPLICATION	3
2	OVERVIEW	4
3	ABSOLUTE MAXIMUM RATINGS	5
4	ELECTRICAL CHARACTERISTICS	5, 6
5	INTERFACE PIN CONNECTION	7, 8
6	RECOMMENDED SEQUENCE	9 ~ 16
7	DISPLAY POSITION AND SCAN DIRECTION	17
8	MECHANICAL SPECIFICATION	18, 19, 20
9	OPTICAL CHARACTERISTICS	21, 22, 23
10	RELIABILITY TEST CONDITION	24
11	OTHER FEATURE	25
12	HANDLING PRECAUTIONS FOR TFT-LCD MODULE	26, 27, 28

1. APPLICATION

This specification applies to color TFT-LCD module, AC035QG01--T1.

These specification papers are the proprietary product of Mitsubishi Electric Corporation (“MITSUBISHI”) and include materials protected under copyright of MITSUBISHI. No part of this document may be reproduced in any form or by any means without the express written permission of MITSUBISHI.

MITSUBISHI does not assume any liability for infringement of patents, copyrights or other intellectual property rights of third parties by or arising from use of a product specified in this document. No license, express, implied or otherwise, is granted under any patents, copyrights or other intellectual property rights of MITSUBISHI or of others.

MITSUBISHI’s TFT-LCD module is designed and produced for “General Application” which is described as below.

<General Application>

Computers, office automation equipment, factory automation equipment, test and measurement equipment, communications, medical equipment which has no impact for human life and body, display equipment utilized in transportation system (automobiles, ships, trains, etc) which has no influence on its operation directly or indirectly.

Therefore, MITSUBISHI do not guarantee using our TFT-LCD for other application such as medical equipment, safety equipment, transportation system which might be influenced for its operation because of LCD-TFT, military systems, defense equipment, aerospace equipment, nuclear reactor control systems, and any other application in which there is a direct or indirect risk for human life and body or where high levels of reliability are required. Please confirm your application before using MITSUBISHI’s TFT-LCD.

Furthermore, it is mandatory to make contract (document base) by both parties (customer and MITSUBISHI), in case if customers intend to use our TFT-LCD for such application as military systems, defense equipment, aerospace equipment and nuclear reactor control systems, “which has significant impact for human life and body”. Otherwise, please do not use MITSUBISHI’s TFT-LCD for any cases.

MITSUBISHI has been making continuous effort to improve the reliability of its products. However customers should implement sufficient reliability design of their application equipments such as redundant system design, fail-safe functions and anti-failure features.

MITSUBISHI assumes no responsibility for any damage, including but not limited to damage to human life and body, resulting from the use of the product for the application other than the above mentioned General Application or the use of the product that does not comply with the instructions and the precautions specified in this document.

2. OVERVIEW

AC035QG01--T1 is 3.5" color TFT-LCD (Thin Film Transistor Liquid Crystal Display) module composed of LCD panel, driver ICs, I/F FPC, backlight unit and touch panel.

240 × 320, 65k-color images are displayed on the 3.5" diagonal screen. Input power voltages are 3.0 V for LCD and 3.0 V for interface.

Driver circuit for LED backlight is not included in this module. General specifications are summarized in the following table:

ITEM	SPECIFICATION
Display Area (mm)	53.64(H) × 71.52(V) (3.5-inch diagonal)
Number of Dots	240 × 3 (H) × 320 (V)
Pixel Pitch (mm)	0.2235 (H) × 0.2235 (V)
Color Pixel Arrangement	RGB vertical stripe
Display Mode	Normally black
Number of Color	262k
Luminance (cd/m ²)	410
Viewing Angle (CR ≥ 10)	-85~85° (H), -85~85° (V)
Surface Treatment (Touch panel)	Anti-glare and hard-coating 3H
Electrical Interface	SPI+RGB
Module Size (mm)	63.5 (W) × 85.0 (H) × 6.17 (D) *)
Module Mass (g)	(65)
Backlight Unit	Edge-light, LED
Touch Panel	4-wire analog resistive

*) W/O FPC

Characteristic value without any note is typical value.

3. ABSOLUTE MAXIMUM RATINGS

ITEM	SYMBOL	MIN.	MAX.	UNIT
Power Supply Voltage for LCD	VCC	-0.3	4.6	V
Power Supply Voltage for Interface	VCCIO	-0.3	4.6	V
Logic Input Voltage	VI	-0.3	VCCIO+0.3	V
Backlight (LED) Current	IF	--	100	mA
Touch Panel Voltage	TPV	--	7.0	V
Operation Temperature Note 1),2)	T _{op}	-20	70	°C
Storage Temperature Note 2)	T _{stg}	-30	80	°C

[Note]

1) MIN.: Measured at the center of panel surface, MAX.: Measured at the center of panel back surface

2) Top, Tstg ≤ 40°C : 90%RH max. without condensation

Top, Tstg > 40°C : Absolute humidity shall be less than the value of 90%RH at 40°C without condensation.

4. ELECTRICAL CHARACTERISTICS

(1) TFT-LCD

Ambient Temperature : Ta = 25°C

ITEM	SYMBOL	MIN.	TYP.	MAX.	UNIT	Remarks
Power Supply Voltage for LCD	VCC	2.4	--	3.6	V	*1)
Power Supply Voltage for Interface	VCCIO	1.65	--	3.6	V	*1)
Power Supply Current for LCD	ICC	--	7	13	mA	*2)
Power Supply Current for Interface	ICCIO	--	0.01	0.03	mA	*2)
Logic Input Voltage	High	VIH	0.7×VCCIO	--	VCCIO	V
	Low	VIL	GND	--	0.3×VCCIO	V
Logic Output Voltage	High	VIH	0.8×VCCIO	--	VCCIO	V
	Low	VIL	GND	--	0.2×VCCIO	V

*1) VCCIO ≤ VCC

*2) Display image at typical power supply current value is at VCC = +3.0 V, VCCIO = +3.0 V, f_H=19 kHz, f_V=60 Hz CPU I/F, and 64-gray-bar pattern (6 bit).

(2) Backlight

ITEM	SYMBOL	MIN.	TYP.	MAX.	UNIT	Remarks
LED Voltage	VF	--	(18.0)	19.5	V	IF = 30 mA, Ta = 25°C
		--	--	20.1	V	IF = 30 mA, Ta = 0°C
		--	--	20.6	V	IF = 30 mA, Ta = -20°C
LED Current	IF	--	30	40	mA	Ta=25°C, *1), *2)
LED Life Time	LT	--	50,000	--	h	IF = 30 mA, Ta = 25°C *3), *4), Continuous operation

[Note]

*1) Constant Current Drive

*2) Lamp Current measurement method

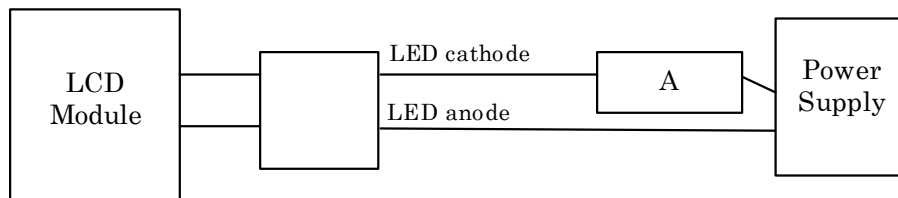

*3) LED life time is defined as the time when the brightness becomes 50% of the initial value.

*4) The life time of the backlight depends on the ambient temperature. The life time will decrease under high temperature.

(3) Touch Panel

Electrical Characteristics

ITEM	MIN.	TYP.	MAX.	UNIT	Remarks
Linearity	-3.0	--	3.0	%	Analog X and Y directions
Terminal Resistance	100	--	700	Ω	X
	300	--	1200	Ω	Y
Insulation Resistance	10	--	--	M Ω	DC 25 V
Voltage	--	5	7	V	DC
Chattering	--	--	20	ms	

*) Do not operate it with a thing except a polyacetal pen (tip R0.8 mm or more) or a finger, especially those with hard or sharp tips such as a ball point pen or a mechanical pencil.

5. INTERFACE PIN CONNECTION

(1) FPC1 (Interface Signal)

Corresponding connector: FH12-40S-0.5SH (HIROSE)

Pin No.	Symbol	I/O *1)	Function
1	LEDA	P	LED (anode)
2	LEDC	P	LED (cathode)
3	NC	--	--
4	VCC	P	Power Supply
5	GND	G	GND
6	GND	G	GND
7	RESX	I	Reset signal
8	CSX	I	SPI) Chip selection
9	DCX	I	SPI) Clock signal
10	WRX	I	SPI) Enable
11	VD	I	Vertical sync signal
12	HD	I	Horizontal sync signal
13	DENA	I	Data enable
14	DCLK	I	Clock signal for sampling catch data signal
15	GND	G	GND
16	SDA	I	SPI) Input signal
17	B0	I	Blue data signal(LSB)
18	B1	I	Blue data signal
19	B2	I	Blue data signal
20	B3	I	Blue data signal
21	B4	I	Blue data signal
22	B5	I	Blue data signal(MSB)
23	G0	I	Green data signal(LSB)
24	G1	I	Green data signal
25	G2	I	Green data signal
26	G3	I	Green data signal
27	G4	I	Green data signal
28	G5	I	Green data signal(MSB)
29	R0	I	Red data signal(LSB)
30	R1	I	Red data signal
31	R2	I	Red data signal
32	R3	I	Red data signal
33	R4	I	Red data signal
34	R5	I	Red data signal(MSB)
35	TE	O	Tearing effect signal is used to synchronize MCU to frame memory
36	SDO	O	SPI) Output signal
37	VCCIO	P	Power supply voltage for interface
38	GND	G	GND
39	ID1	O	Output level is GND
40	ID0	O	Output level is GND

*1) I/O : P= Power Supply, G=GND, I=Input, O=Output

(2) FPC 2 (Touch Panel Interface)

Pin No.	Symbol
1	XR
2	YD
3	XL
4	YU

(3) Touch Panel

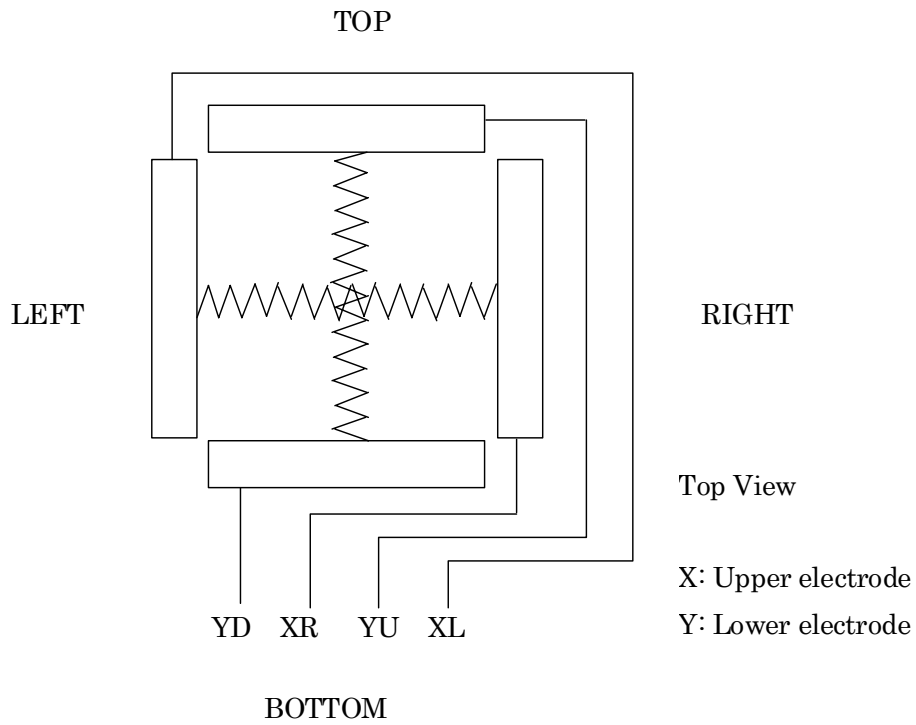

6. Timing Specifications

See: Data sheet of Driver IC (ST7789VI (Sitronix))

(1) Timing Specifications

- 4line serial setting

a. AC Characteristics

Ta = 25°C

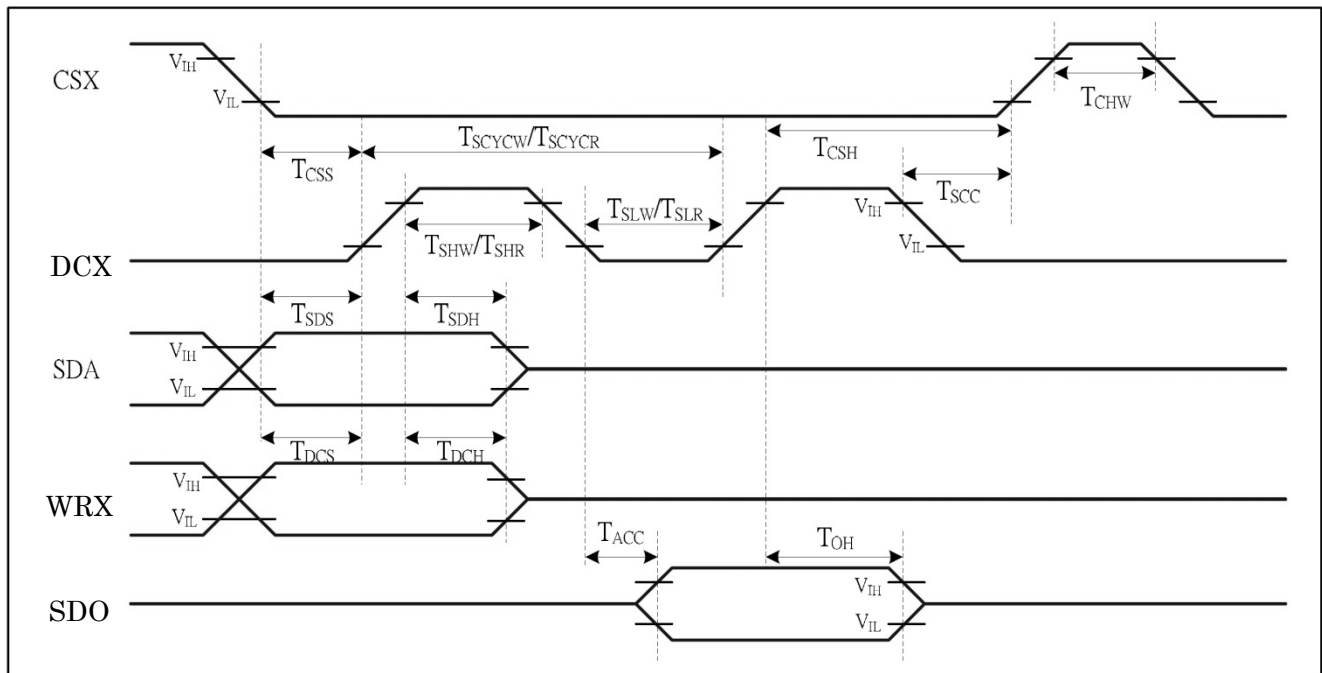

	ITEM	SYMBOL	MIN.	MAX.	UNIT	Remarks
CSX	Set up time (write)	T_{CSS}	15	--	ns	
	Hold time (write)	T_{CSH}	15	--	ns	
	Set up time (read)	T_{CSS}	60	--	ns	
	Hold time (read)	T_{CSH}	65	--	ns	
	Pulse Width (High)	T_{CHW}	40	--	ns	
DCX	Period (write)	T_{SCYCW}	66	--	ns	-write command & data ram
	Pulse Width(High) (write)	T_{SHW}	15	--	ns	
	Pulse Width(Low) (write)	T_{SLW}	15	--	ns	
	Period (read)	T_{SCYCR}	150	--	ns	-read command & data ram
	Pulse Width(High) (read)	T_{SHR}	60	--	ns	
	Pulse Width(Low) (read)	T_{SLR}	60	--	ns	
WRX	Set up time	T_{DCS}	10	--	ns	
	Hold time	T_{DCH}	10	--	ns	
SDA	Set up time	T_{SDS}	10	--	ns	
	Hold time	T_{SDH}	10	--	ns	
SDO	Access time	T_{ACC}	10	50	ns	For maximum CL=30pF For minimum CL=8pF
	Output disable time	T_{CH}	15	50	ns	

b. Write protocol

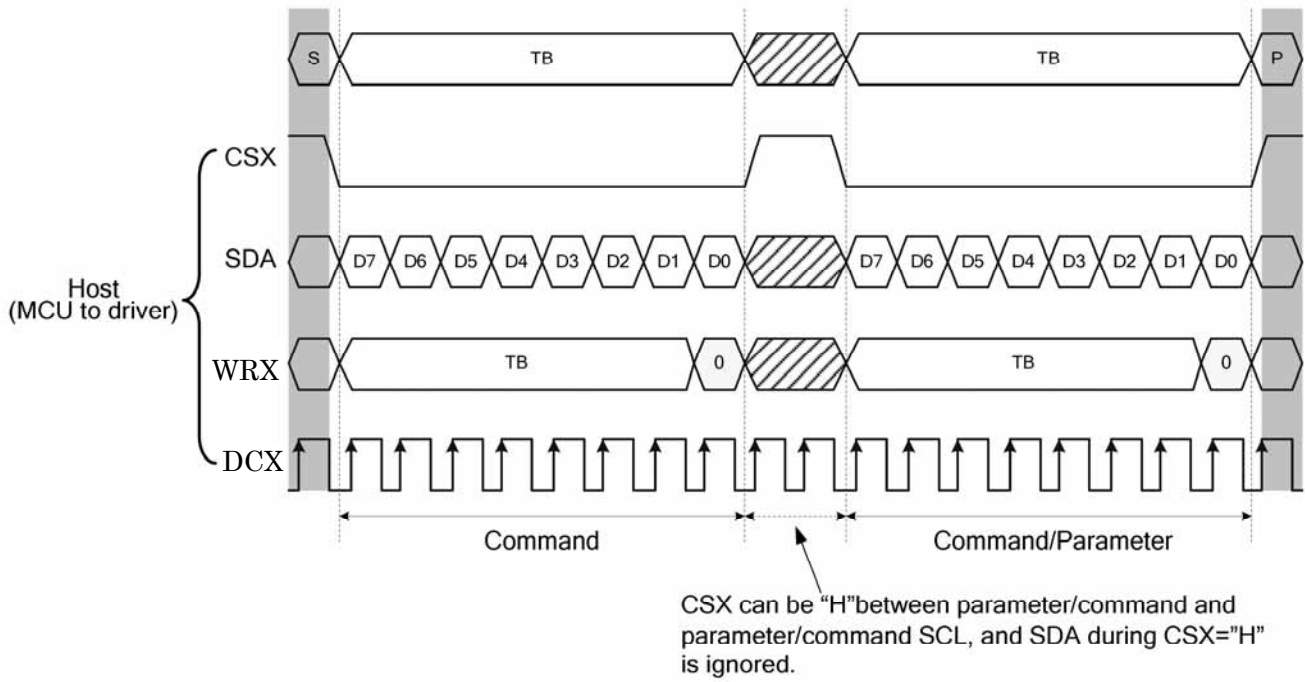

c. Reset timing

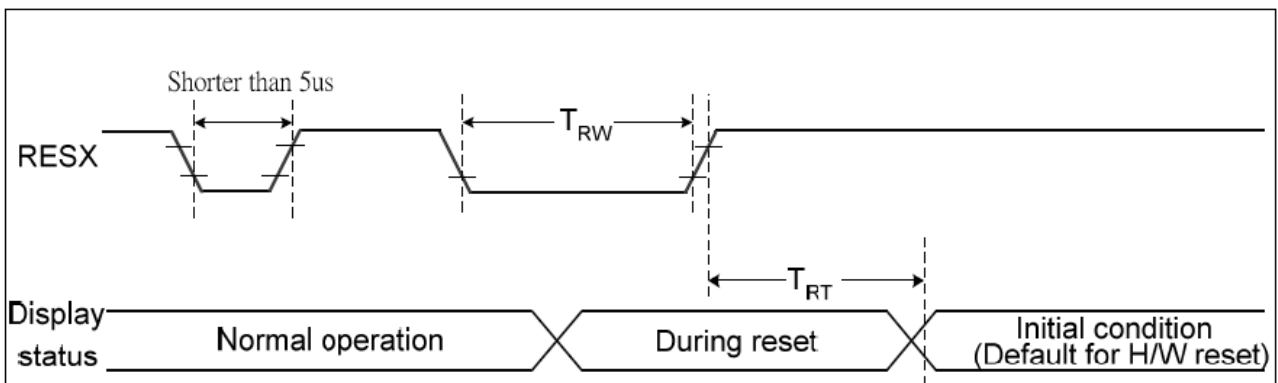

ITEM	SYMBOL	parameter	MIN.	MAX.	UNIT
RESX	T_{RW}	Reset pulse duration	10	--	μs
	T_{RT}	Reset cancel (Sleep in)	--	5	ms
		Reset cancel (Sleep out)	--	120	ms

d. Power ON/OFF sequence

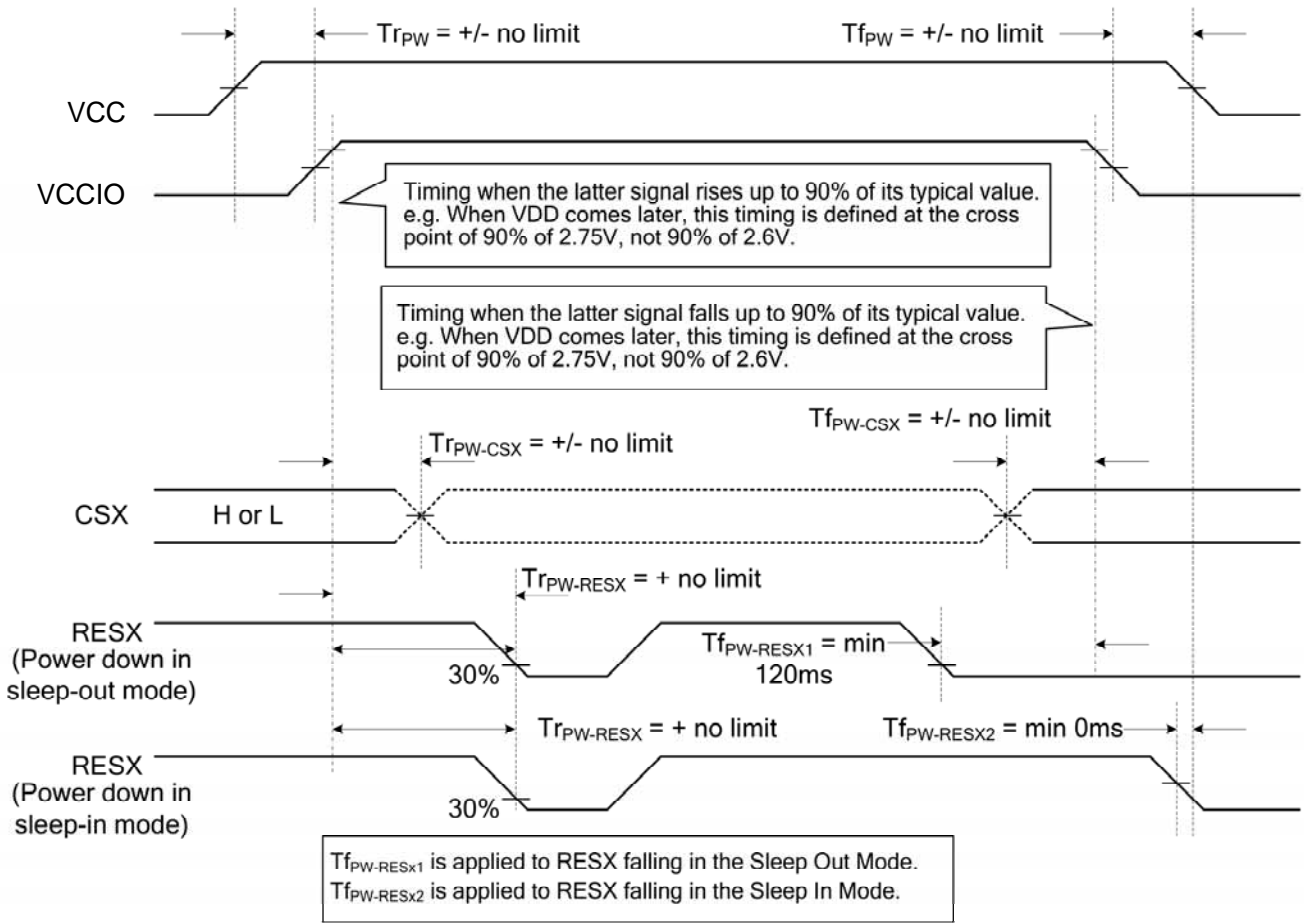

(2) Reference Command data (4-line 8bit serial I/F)

Hardware reset	1ms		
↓			
Command reset	10ms		
↓			
Oscillation circuit start	120ms		
↓			
Display setting	Command	Data	
	11h	120ms	
	36h	00h	fixed
	21h		fixed
3Ah	06h	fixed	
↓			
Timing setting	Command	Data	
	B2h	0Ch	
		0Ch	
		00h	
		33h	
B7h	56h	fixed	
B8h	2Ah	fixed	
	2Bh	fixed	
	22h	fixed	
	75h	fixed	
↓			
Voltage setting Should be fixed	Command	Data	
	BBh	14h	fixed
	C0h	2Ch	fixed
	C2h	01h	fixed
	C3h	21h	fixed
	C4h	20h	fixed
	C5h	20h	fixed
	C6h	1Fh	fixed
	D0h	A4h	fixed
B2h		fixed	
↓			

Gamma setting	Command	Data	fixed
	E0h	F0h	fixed
		0Ah	fixed
		10h	fixed
		0Ah	fixed
		09h	fixed
		06h	fixed
		36h	fixed
		44h	fixed
		4Dh	fixed
		09h	fixed
		15h	fixed
		15h	fixed
		2Eh	fixed
		32h	fixed
	E1h	F0h	fixed
		0Bh	fixed
		10h	fixed
		0Ah	fixed
		09h	fixed
		06h	fixed
		35h	fixed
		33h	fixed
		4Dh	fixed
07h		fixed	
14h	fixed		
14h	fixed		
2Eh	fixed		
33h	fixed		



RGB I/F setting	Command	Data	
	E9h	09h	
		09h	
		08h	
	B1h	E2h	
		02h	
		14h	
	B0h	11h	
		33h	



Display starts	Command	Data	
	29h		

- 1) Please fix the parameters that are described as "fixed".
- 2) IC setting is done at every power-on. But data is recommended to be written in the register regularly.

a. RGB data
AC Characteristics

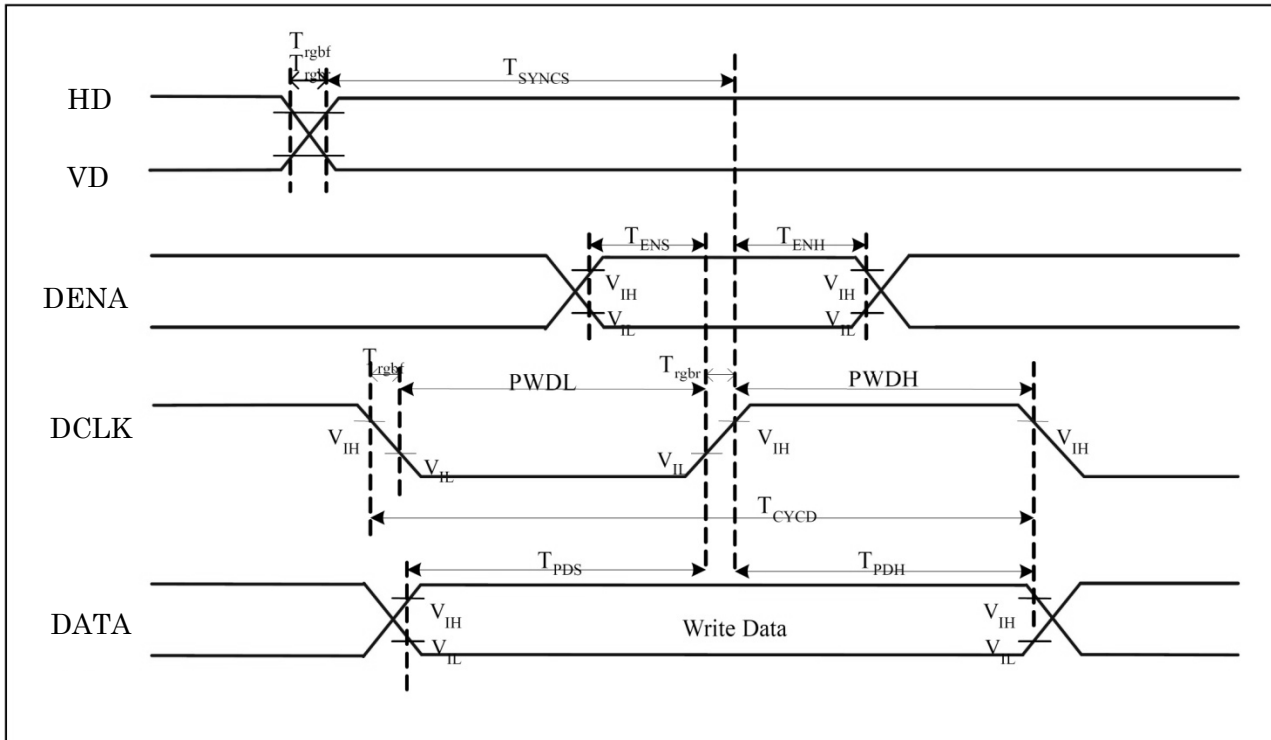

ITEM		SYMBOL	MIN.	MAX.	UNIT
HD,VD	Set up time	T _{SYNCS}	30	--	ns
DENA	Set up time	T _{ENS}	25	--	ns
	Hold time	T _{ENH}	25	--	ns
DCLK	Pulse Width (High)	PWDH	62.5	--	ns
	Pulse Width (Low)	PWDL	62.5	--	ns
	Period	T _{CYCD}	125	200	ns
	Rise/Fall time	T _{rghr} , T _{rghf}	--	20	ns
DATA	Set up time	T _{PDS}	50	--	ns
	Set up time	T _{PDH}	50	--	ns

(3) Timing Chart

a. Horizontal Timing Chart

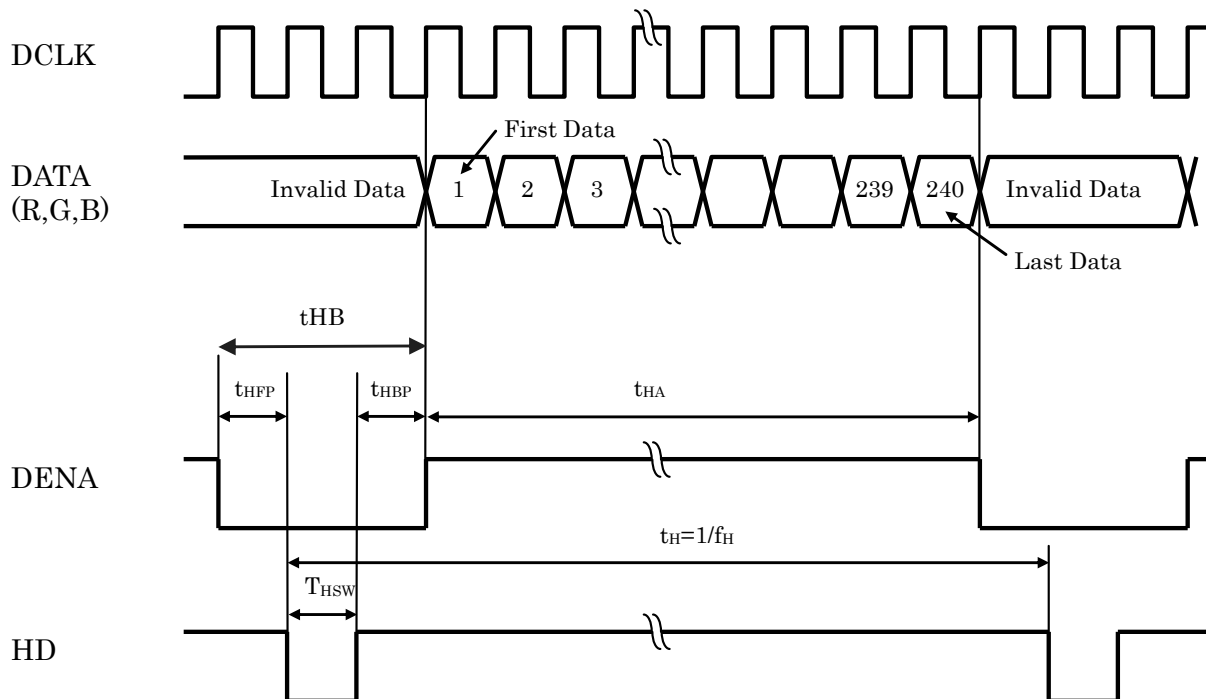

b. Vertical Timing Chart

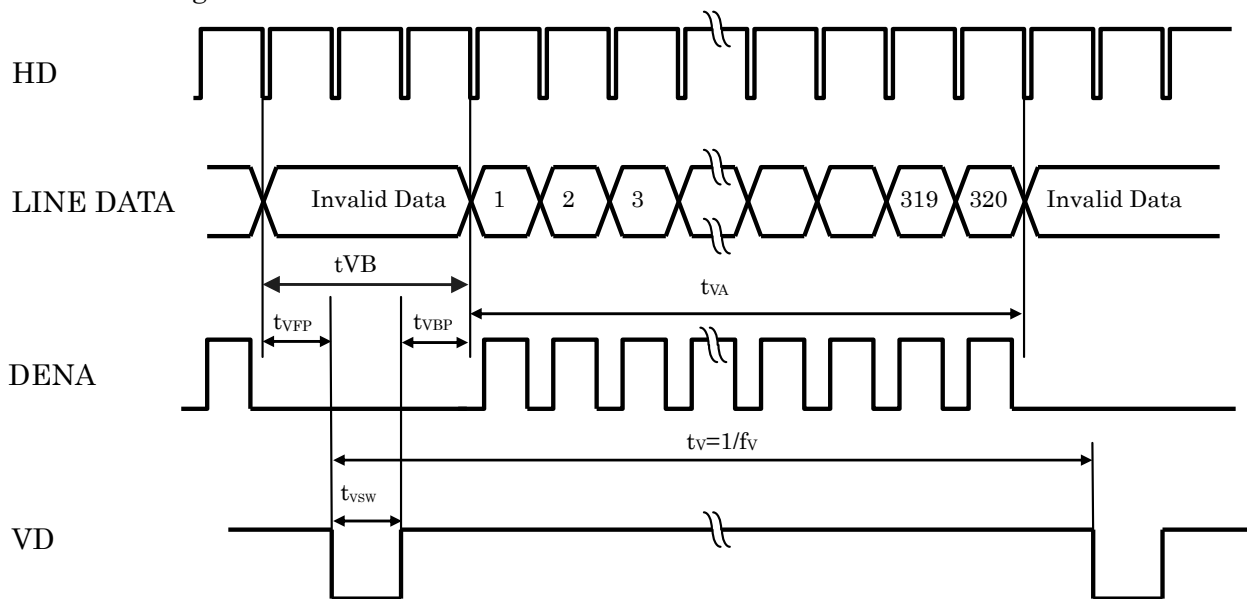

	ITEM	SYMBOL	MIN.	TYP.	MAX.	UNIT	Remarks
DCLK	Frequency	felk	5.0	6.7	8.0	MHz	
Horizontal	Active Time	tHA	240	240	240	tCLK	
	Blanking Time	tHB	8	80	--	tCLK	DENA mode
	Back Porch *1)	tHBP	4	6	--	tCLK	SYNC mode *2)
	Horizontal Sync Width	tHSW	2	14	--	tCLK	SYNC mode *2)
	Frequency	fH	--	--	--	Hz	
	Period	tH	--	--	--	us	
Vertical	Active Time	tVA	320	320	320	tH	
	Blanking Time	tVB	6	30	--	tH	DENA mode
	Back Porch *1)	tVBP	2	2	--	tH	SYNC mode *3)
	Vertical Sync Width	tVSW	2	2	--	tH	SYNC mode *3)
	Frequency	fV	55	60	70	Hz	
	Period	tV	14.3	16.7	18.2	ms	

*1) W/O Pulse width

*2) $20 \leq tHBP+tHSW \leq 31$, Should be same as 6. Timing specifications.

*3) $tVBP+tVSW \leq 127$, Should be same as 6. Timing specifications.

7. DISPLAY POSITION AND SCAN DIRECTION

D(X,Y) shows the data number of input signal.

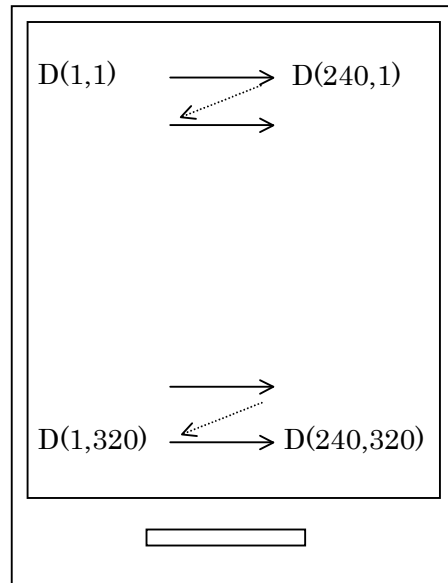

8. MECHANICAL SPECIFICATIONS

(1) Outline Dimensions

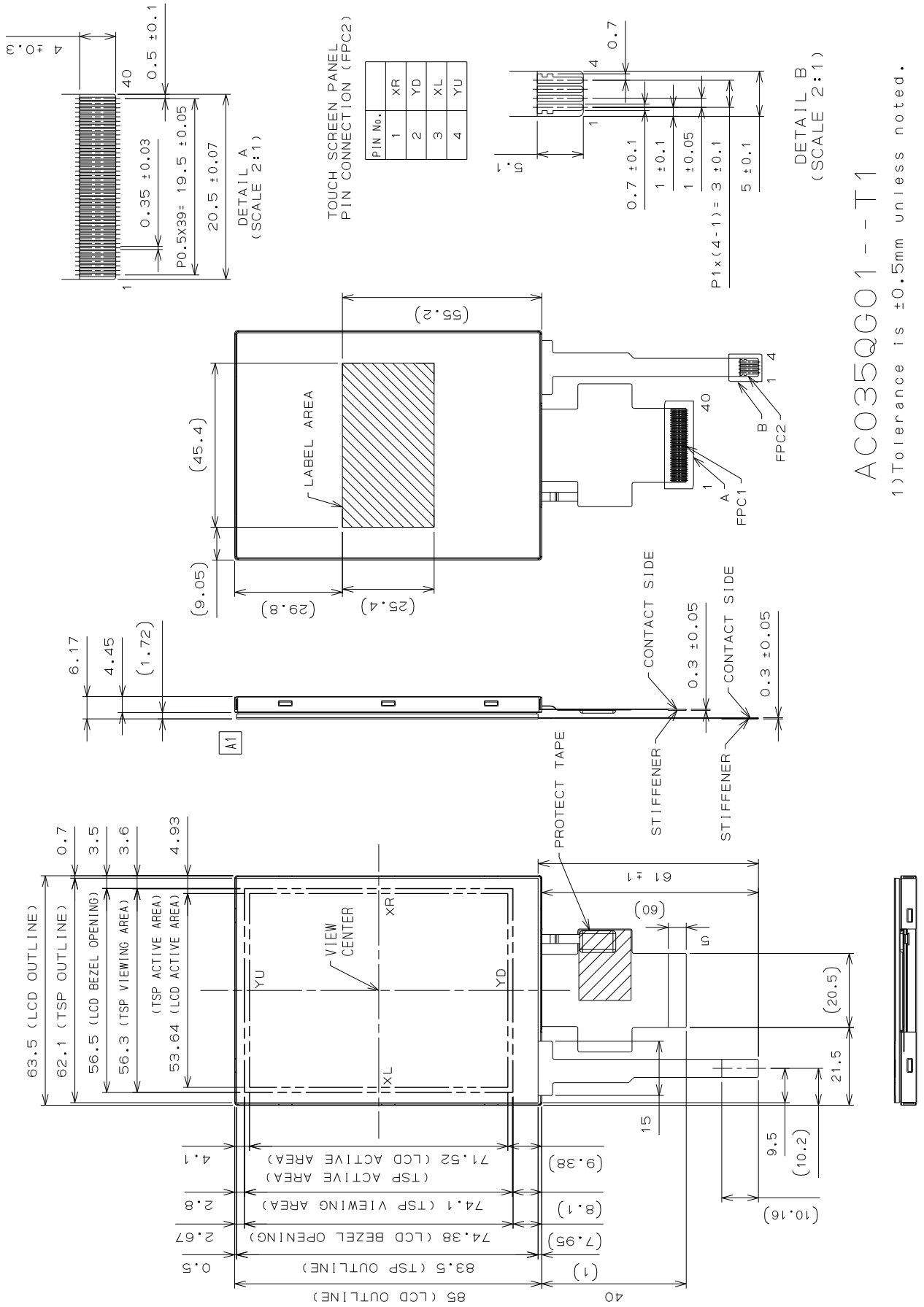

(Unit:mm)

(2) Touch Panel

a. Mechanical Characteristics

ITEM		MIN.	TYP.	MAX.	UNIT	Remarks
Minimum Operation force	Pen / Finger	0.02	--	0.78	N	*1)
	Finger pulp	0.02	--	1.0	N	*1)
Surface Hardness		3	--	--	H	JIS K5400

*1) Measurement condition of Operation force

Within "Guaranteed active area"(Excepted top of the dot.) Resistance between X & Y axis must be equal or lower than 2kΩ (Ron 2kΩ).

• Measuring instrument

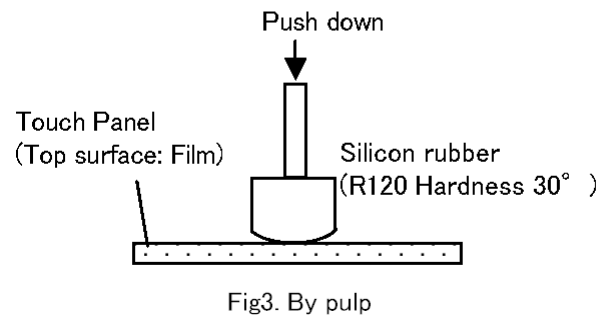
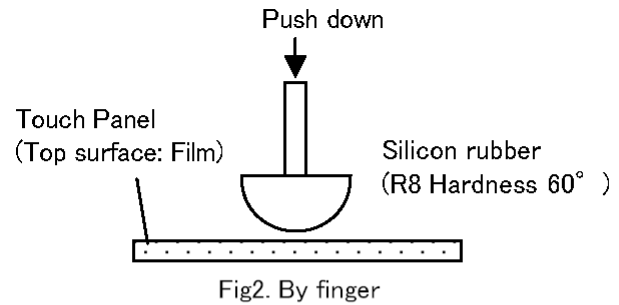
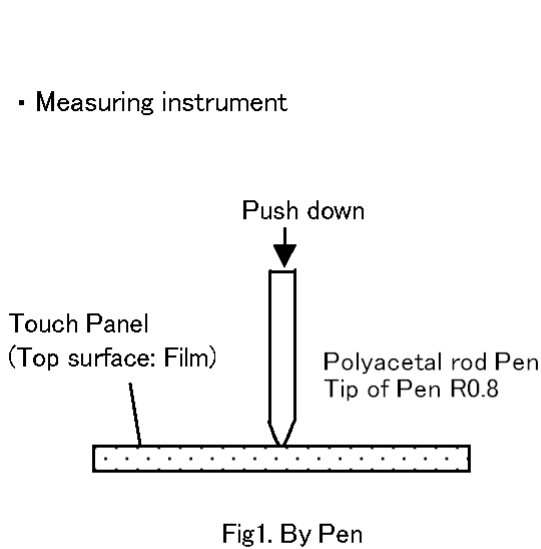

b. Operating durability

Tapping life by Finger	10 ⁶ times	*1)
Durability of Pen writing	10 ⁵ times	*2)

*1) Test condition of Tapping life by Finger

Test method	Tapping at same points by Silicon rubber. <ul style="list-style-type: none"> • Shape of rubber end: R8 Hardness 60° (See (3) a.*1)) • Load: 2.45N (250gf) • Frequency: 3Hz
-------------	---

*2) Test condition of Operating durability by Pen

Test method	The characters are written on the touch panel and the size of the word is 7.5 × 6.75mm, area is 10 × 9mm. The characters are Japanese words and written at random on the area. <ul style="list-style-type: none"> • Shape of Pen tip: R0.8 (Refer Fig.1) • Material of Pen: Polyacetal resin • Force: 2.45N (250gf)
-------------	--

c. Design Guide

- Avoid the design that Front-case overlap and press on the active area of the touch-panel.
- Give enough gap (over 0.5 mm at compressed) between the front case and touch-panel to protect wrong operating.
- Use a buffer material (Gasket) between the touch-panel and Front-case to protect damage and wrong operating.
- Avoid the design that buffer material overlap and press on the inside of touch-panel viewing area.
- The flexible tail section should be designed to avoid stress from the front case and/or avoid any bending stress to root of flexible tail section.
- Please avoid any strong forces, such as pen input in the area between display area and insulated area (distance: >2mm), because it may cause damage to the film.
- When you handle the product, hold the product by its body. Do not hold by the FPC.

9. OPTICAL CHARACTERISTICS

Ta=25°C, VCC=3.0V, VCCIO=3.0V, Input Signals: Typ. values shown in Section 6

ITEM		SYMBOL	CONDITION	MIN.	TYP.	MAX.	UNIT	Remarks
Contrast Ratio		CR	$\theta_V=0^\circ, \theta_H=0^\circ$	610	950	--	--	*1)*2)*4)
Luminance		Lw	$\theta_V=0^\circ, \theta_H=0^\circ$	320	410	--	cd/m ²	*1)*4)
Response Time		tr	$\theta_V=0^\circ, \theta_H=0^\circ$	--	12	--	ms	*1)*3)*4)
		tf	$\theta_V=0^\circ, \theta_H=0^\circ$	--	12	--	ms	*1)*3)*4)
Viewing Angle	Horizontal	θ_H	CR \geq 10	-70~70	-85~85	--	--	*1)*4)
	Vertical	θ_V		-70~70	-85~85	--	--	*1)*4)
Image Sticking		tis	2 h	--	--	2	s	*5)
Color Coordinates	Red	Rx	$\theta_V=0^\circ, \theta_H=0^\circ$	0.526	0.576	0.626	--	*1)*4)
		Ry		0.260	0.310	0.360		
	Green	Gx		0.286	0.336	0.386		
		Gy		0.535	0.585	0.635		
	Blue	Bx		0.106	0.156	0.206		
		By		0.085	0.135	0.185		
	White	Wx		0.263	0.313	0.363		
		Wy		0.279	0.329	0.379		

[Note]

These items are measured using EZContrast XL88F(ELDIM) for viewing angle, RD-80SA(TOPCON) for response time and CS-2000 (KONICA MINOLTA) or equivalent equipment for others under the dark room condition (no ambient light) after more than 30 minutes from turning on the backlight unless noted.

Condition: IF = 30 mA

Measurement method for luminance and color coordinates is as follows.

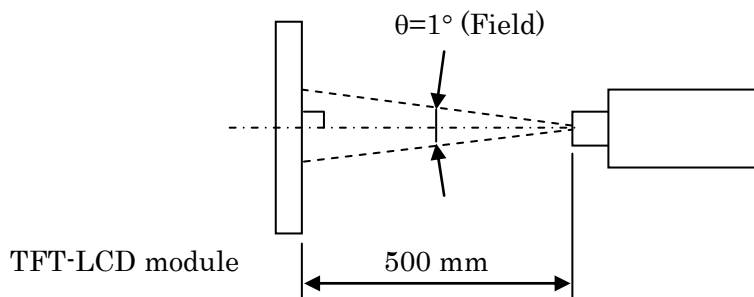

The luminance is measured according to FLAT PANEL DISPLAY MEASUREMENTS STANDARD (VESA Standard).

*1) Measurement Point

Contrast Ratio, Luminance, Response Time, Viewing Angle, Color Coordinates: Display Center

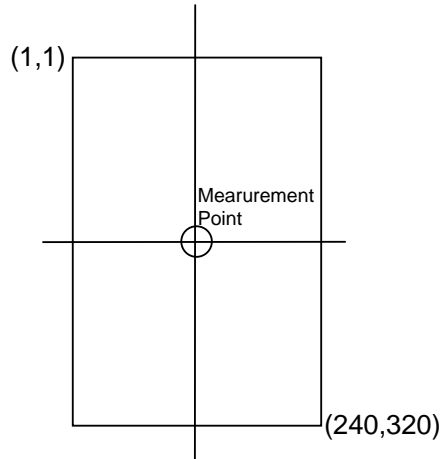

*2) Definition of Contrast Ratio

CR=Luminance with all white pixels / Luminance with all black pixels

*3) Definition of Response Time

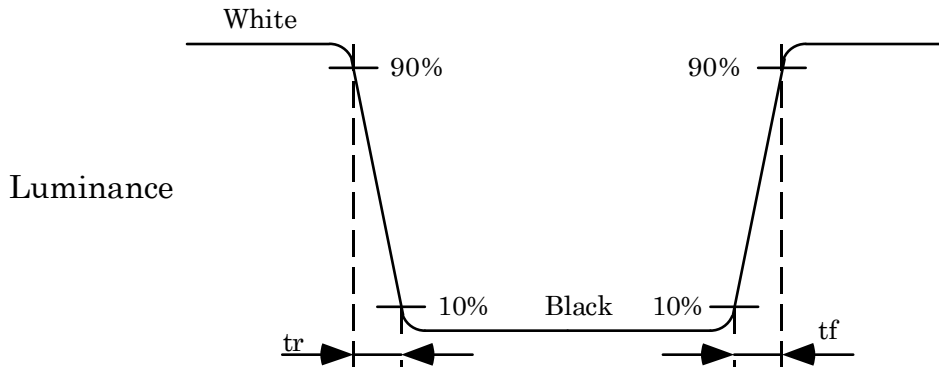

*4) Definition of Viewing Angle (θ_v , θ_H)

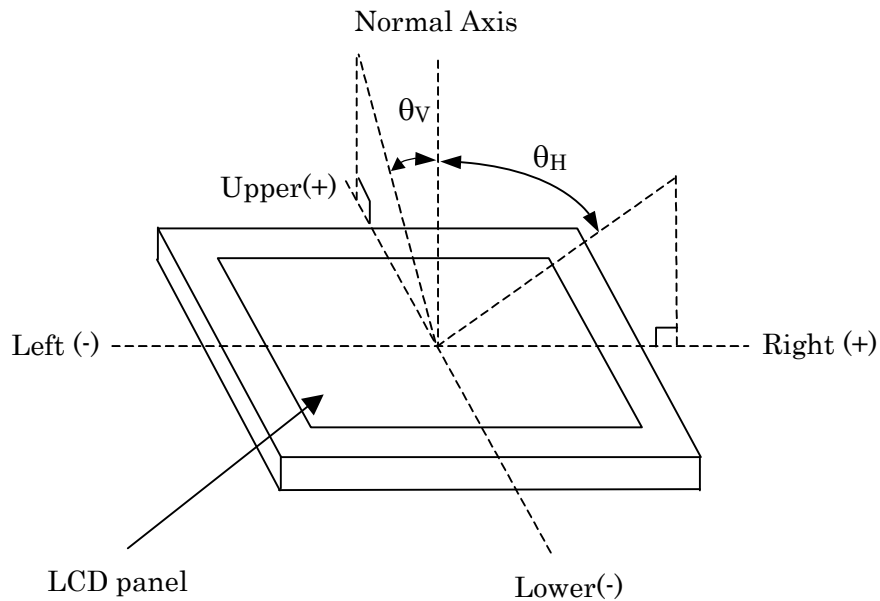

*5) Image Sticking

Continuously display the test pattern shown in the figure below for two-hours. Then display a completely white screen. The previous image shall not persist more than two seconds at 25°C.

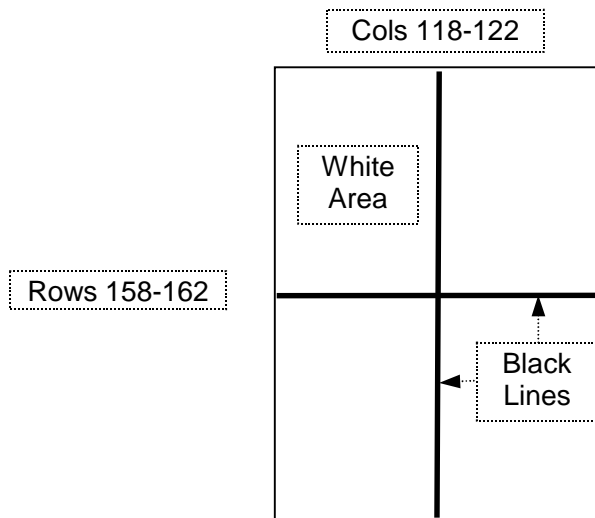

TEST PATTERN FOR IMAGE STICKING TEST

10. RELIABILITY TEST CONDITION

(1) Temperature and Humidity

ITEM	CONDITIONS
HIGH TEMPERATURE HIGH HUMIDITY OPERATION	40°C, 90%RH, 240 h (No condensation)
HIGH TEMPERATURE OPERATION	70°C, 240 h
LOW TEMPERATURE OPERATION	-20°C, 240 h
HIGH TEMPERATURE STORAGE	80°C, 240 h
LOW TEMPERATURE STORAGE	-30°C, 240 h
THERMAL SHOCK (NON-OPERATION)	-30°C (1h) ~ 80°C(1h), 100 cycles

(2) Shock & Vibration

ITEM	CONDITIONS
SHOCK (NON-OPERATION)	Shock level: 1470m/s ² (150G) Waveform: half sinusoidal wave, 2ms Number of shocks: one shock input in each direction of three mutually perpendicular axis for a total of six shock inputs
VIBRATION (NON-OPERATION)	Vibration level: 9.8m/s ² (1.0G) Waveform: sinusoidal Frequency range: 5 to 500Hz Frequency sweep rate: 0.5 octave /min Duration: one sweep from 5 to 500 Hz in each of three mutually perpendicular axis(each x,y,z axis: 1 hour, total 3 hours)

(3) Judgment standard

The judgment of the above tests should be made as follow:

Pass: Normal display image, no damage of the display function. (ex. no line defect)

Partial transformation of the module parts should be ignored.

Fail: No display image, damage of the display function. (ex. line defect)

11. OTHER FEATURE

This LCD module complies with RoHS^{*)} directive.

^{*)} RoHS: Restriction of the use of certain hazardous substances in electrical and electronic equipment

12. HANDLING PRECAUTIONS FOR TFT-LCD MODULE

Please pay attention to the followings in handling TFT-LCD products;

(1) ASSEMBLY PRECAUTION

- a. Please do not bend or wrench the LCD module in assembling. Please do not drop, bend or twist the LCD module in handling.
- b. Please design display housing in accordance with the following guide lines.
 - (a) Housing case must be designed carefully so as not to put stresses on LCD and not to wrench module.
 - (b) Under high temperature environment, performance and life time of LED may heavily shorten. When you design with our LCD product, please consider radiating heat and ventilation for good heat management.
 - (c) Keep sufficient clearance between LCD module back surface and housing when the LCD module is mounted. Approximately 1.0mm of the clearance in the design is recommended taking into account the tolerance of LCD module thickness and mounting structure height on the housing.
 - (d) When some parts, such as, FPC cable and ferrite plate, are installed underneath the LCD module, still sufficient clearance is required, such as 0.5mm. This clearance is, especially, to be reconsidered when the additional parts are implemented for EMI countermeasure.
 - (e) Design the LED driver location and connector position carefully so as not to give stress to LED backlight cable and flexible tail.
 - (f) Keep sufficient clearance between LCD module and the others parts, such as inverter and speaker so as not to interfere the LCD module. Approximately 1.0 mm of the clearance in the design is recommended.
 - (g) To avoid local elevation/decrease of temperature, considering location of heating element, heat release, thermal design should be done.
- c. Please do not push or scratch touch panel surface with anything hard.
- d. Do not use or store the product under a condition where the product will be exposed to water, organic solution or acid.
- e. Please wipe off touch panel surface with absorbent cotton or soft cloth in case of it being soiled.
- f. Touch panel glass edge is not rounded. Please take care in handling to avoid injury.
- g. Please do not take a LCD module to pieces and reconstruct it. Resolving and reconstructing modules may cause them not to work well.
- h. Please do not touch metal frames with bare hands and soiled gloves. A color change of the metal frames can happen during a long preservation of soiled LCD modules.
- i. Please handle metal frame carefully because edge of metal frame is very sharp.
- j. Please connect the metal frame of LCD module to GND in order to minimize the effect of external noise and EMI.
- k. Be sure to connect the cables and the connectors correctly.

(2) OPERATING PRECAUTIONS

- a. Please be sure to turn off the power supply before connecting and disconnecting signal input cable.
- b. Please do not change variable resistance settings in LCD module. They are adjusted to the most suitable value. If they are changed, it might happen LCD does not satisfy the characteristics specification.
- c. The interface signal speed is very high. Please pay attention to transmission line design and other high speed signal precautions to satisfy signal specification.
- d. Condensation might happen on the surface and inside of LCD module in case of sudden change of ambient temperature. Do not use touch panel when there is condensation. It could cause touch panel failure.
- e. Please pay attention not to display the same pattern for very long time. Image sticking might happen on LCD. Although image sticking may disappear as the operation time proceeds, screen saver function is recommended not to cause image sticking.
- f. Please obey the same safe instructions as ones being prepared for ordinary electronic products.

(3) PRECAUTIONS WITH ELECTROSTATICS

- a. This LCD module use CMOS-IC on circuit board and TFT-LCD panel, and so it is easy to be affected by electrostatics. Please be careful with electrostatics by the way of your body connecting to the ground and so on.
- b. Please remove protection film very slowly from the surface of touch panel to prevent from electrostatics occurrence.

(4) STORAGE PRECAUTIONS

LCD should be stored in the room temperature environment with normal humidity. The LCD inventory should be processed by first-in first-out method.

(5) SAFETY PRECAUTIONS

- a. When you waste damaged or unnecessary LCDs, it is recommended to crush LCDs into pieces and wash them off with solvents such as acetone and ethanol, which should later be burned.
- b. If any liquid leaks out of a damaged glass cell and comes in contact with the hands, wash off thoroughly with soap and water.
- c. Be sure to turn off the power supply when inserting or disconnecting the LED backlight cable.
- d. LED driver should be designed carefully to limit or stop its function when over current is detected on the LED.

(6) OTHERS

- a. A strong incident light into LCD panel may cause deterioration to touch panel, polarizer film, color filter, and other materials, which will degrade the quality and performance of display.
Please do not expose LCD module under strong Ultraviolet rays for a long time. If using under direct sunlight condition, please test the reliability and performance completely.
- b. For the packaging box handling, please see and obey with the packaging specification datasheet.