

AUO Display Plus Confidential
FOR SYMMETRON ONLY
20210415 17:30:14

- () Preliminary Specification
- (V) Final Specification

| | |
|------------|---------------------|
| Module | 21.5" Color TFT-LCD |
| Model Name | P215HVN01.2 |

AUO Display Plus Confidential
FOR SYMMETRON ONLY
20210415 17:30:14

ADP Confidential for ADP Internal Use Only
AUO Display Plus Confidential
FOR SYMMETRON ONLY
20210415 17:30:14

AUO Display Plus Confidential
FOR SYMMETRON ONLY
20210415 17:30:14



| | |
|-------------------------------------|---|
| <p>Customer _____ Date _____</p> | <p>Approved by _____ Date _____</p> |
| <p>Approved by _____</p> | <p><u>CT.Wu</u> Jan.31. 2021</p> |
| <p>Approved by _____</p> | <p>Prepared by _____ Date _____</p> |
| <p>_____</p> | <p><u>Sophie. Teng</u> Jan.31. 2021</p> |
| <p>ADP Display Plus Corporation</p> | |

Contents

| | |
|--|-----------|
| 1 Handling Precautions | 5 |
| 2 General Description | 6 |
| 2.1 Display Characteristics..... | 6 |
| 2.2 Absolute Maximum Rating of Environment | 7 |
| 2.3 Optical Characteristics | 8 |
| 2.4 Mechanical Characteristics | 12 |
| 3 TFT-LCD Module | 14 |
| 3.1 Block Diagram..... | 14 |
| 3.2 Interface Connection..... | 15 |
| 3.2.1 Connector Type..... | 15 |
| 3.2.2 Connector Pin Assignment..... | 15 |
| 3.3 Electrical Characteristics..... | 17 |
| 3.3.1 Absolute Maximum Rating | 17 |
| 3.3.2 Recommended Operating Condition..... | 17 |

| | |
|--|-----------|
| 3.4 Signal Characteristics | 18 |
| 3.4.1 LCD Pixel Format..... | 18 |
| 3.4.2 LVDS Data Format..... | 18 |
| 3.4.3 Color versus Input Data | 19 |
| 3.4.4 LVDS Specification..... | 20 |
| 3.4.5 Input Timing Specification | 22 |
| 3.4.6 Input Timing Diagram..... | 23 |
| 3.5 Power ON/OFF Sequence | 24 |
| 4 Backlight Unit | 26 |
| 4.1 Block Diagram..... | 26 |
| 4.2.1 Connector Type..... | 27 |
| 4.2.2 Connector Pin Assignment..... | 29 |
| 4.3.1 Absolute Maximum Rating | 30 |
| 4.3.2 Recommended Operating Condition..... | 30 |
| 5 Reliability Test | 32 |
| 6 Shipping Label | 33 |
| 7 Mechanical Characteristics | 34 |
| 8 Packing Specification | 36 |
| 8.1 Packing Flow..... | 36 |
| 8.2 Pallet and shipment information..... | 37 |

Record of Revision

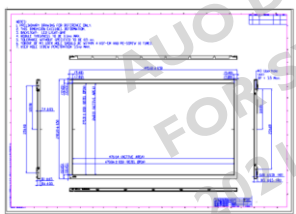
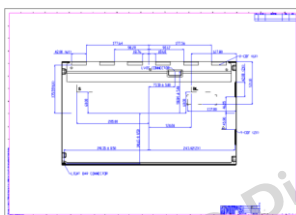
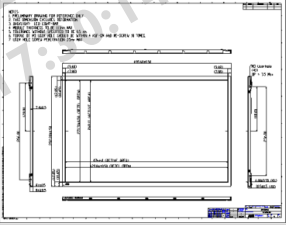
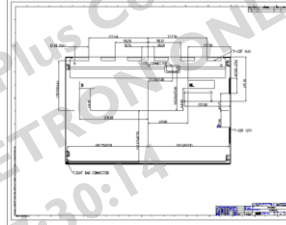
| Version | Date | Page | Old description | New Description | Remark |
|---------|------------|---------|--|--|--------|
| 0.0 | 2021/1/13 | | | Preliminary Specification | |
| 1.0 | 2021/01/31 | P30 | 6 Shipping Label  | 6 Shipping Label  | |
| 1.0 | 2021/01/31 | P31~P32 | 6 Mechanical Characteristic   | 6 Mechanical Characteristic   | |
| | | | | | |
| | | | | | |
| | | | | | |
| | | | | | |
| | | | | | |

1 Handling Precautions

- 1) Since front polarizer is easily damaged, pay attention not to scratch it.
- 2) Be sure to turn off power supply when inserting or disconnecting from input connector.
- 3) Wipe off water drop immediately. Long contact with water may cause discoloration or spots.
- 4) When the panel surface is soiled, wipe it with absorbent cotton or other soft cloth.
- 5) Since the panel is made of glass, it may break or crack if dropped or bumped on hard surface.
- 6) Since CMOS LSI is used in this module, take care of static electricity and insure human earth when handling.
- 7) Do not open or modify the Module Assembly.
- 8) Do not press the reflector sheet at the back of the module to any directions.
- 9) In case a TFT-LCD Module has to be put back into the packing container slot after once it was taken out from the container, do not press the center of the LED lightbar edge. Otherwise the TFT-LCD Module may be damaged.
- 10) Insert or pull out the interface connector, be sure not to rotate nor tilt it of the TFT-LCD Module.
- 11) Do not twist nor bend the TFT -LCD Module even momentary. It should be taken into consideration that no bending/twisting forces are applied to the TFT-LCD Module from outside. Otherwise the TFT-LCD Module may be damaged.
- 12) Please avoid touching COF position while you are doing mechanical design.
- 13) When storing modules as spares for a long time, the following precaution is necessary:
Store them in a dark place. Do not expose the module to sunlight or fluorescent light. Keep the temperature between 5°C and 35°C at normal humidity.



2 General Description

This specification applies to the 21.5 inch wide Color a-Si TFT-LCD Module P215HVN01.2. The display supports the Full HD - 1920(H) x 1080(V) screen format and 16.7M colors (8 bits RGB data input). The input interface is Dual channel LVDS and this module doesn't contain an driver board for backlight.

2.1 Display Characteristics

The following items are characteristics summary on the table under 25°C condition:

| ITEMS | Unit | SPECIFICATIONS |
|---|----------------------|--|
| Screen Diagonal | [mm] | 546.86 (21.53") |
| Active Area | [mm] | 476.64 (H) x 268.11 (V) |
| Pixels H x V | - | 1920(x3) x 1080 |
| Pixel Pitch | [um] | 248.25 (per one triad) x248.25 |
| Pixel Arrangement | - | R.G.B. Vertical Stripe |
| Display Mode | - | VA Mode, Normally Black |
| White Luminance (Center) | [cd/m ²] | 250 (Typ.) |
| Contrast Ratio | - | 3000 (Typ.) |
| Response Time | [msec] | 18ms (Typ., on/off) |
| Power Consumption (LCD Module + Backligh unit) | [Watt] | 14.3 (Typ.) LCD module : PDD (Typ.)= 3.1 @ all white pattern,Fv=60Hz Backlight unit : P _{BLU} (Typ.) =11.2 @Is=60mA |
| Weight | [Grams] | 1670 |
| Outline Dimension | [mm] | 495.6(H) x 292.2(V) x 10.6(D) Typ. |
| Electrical Interface | - | Dual channel LVDS , 8 bits RGB data input |
| Support Color | - | 16.7M colors |
| Surface Treatment | - | Anti-Glare, 3H |
| Temperature Range | | |
| Operating | [°C] | 0 to +50 |
| Storage (Shipping) | [°C] | -20 to +60 |
| RoHS Compliance | - | RoHS Compliance |
| TCO Compliance | - | TCO 7.0 Compliance |



2.2 Absolute Maximum Rating of Environment

Permanent damage may occur if exceeding the following maximum rating.

| Symbol | Description | Min. | Max. | Unit | Remark |
|--------|---------------------------------------|------|------|-------|---|
| TOP | Operating Temperature | 0 | +50 | [°C] | Note 2-1 |
| TGS | Glass surface temperature (operation) | 0 | +65 | [°C] | Note 2-1 Function judged only |
| HOP | Operation Humidity | 5 | 90 | [%RH] | Note 2-1 |
| TST | Storage Temperature | -20 | +60 | [°C] | |
| HST | Storage Humidity | 5 | 90 | [%RH] | |

Note 2-1: Temperature and relative humidity range are shown as the below figure.

1. 90% RH Max ($T_a \leq 39^\circ\text{C}$)
2. Max wet-bulb temperature at 39°C or less. ($T_a \leq 39^\circ\text{C}$)
3. No condensation

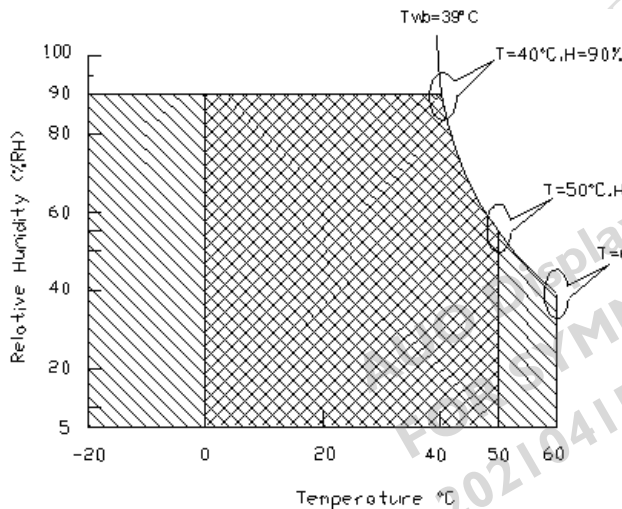

Operating Range



Storage Range

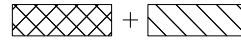



2.3 Optical Characteristics

The optical characteristics are measured on the following test condition.

Test Condition:

1. Equipment setup: Please refer to **Note 2-2**.
2. Panel Lighting time: 30 minutes
3. VDD=5.0V, Fv=60Hz, Is=60mA, Ta=25°C

| Symbol | Description | Min. | Typ. | Max. | Unit | Remark | |
|------------------|-------------------------------------|------------------|-------|-------|----------------------|--|---|
| L _w | White Luminance (Center of screen) | 200 | 250 | - | [cd/m ²] | Note 2-2 By SR-3 | |
| L _{uni} | Luminance Uniformity (9 points) | 75 | 80 | - | [%] | Note 2-3 By SR-3 | |
| CR | Contrast Ratio (Center of screen) | 2000 | 3000 | - | - | Note 2-4 By SR-3 | |
| θ _R | Horizontal Viewing Angle (CR=10) | Right | 75 | 89 | - | [degree] Note 2-5 By SR-3 | |
| θ _L | | Left | 75 | 89 | - | | |
| Φ _H | Vertical Viewing Angle (CR=10) | Up | 75 | 89 | - | | |
| Φ _L | | Down | 75 | 89 | - | | |
| θ _R | Horizontal Viewing Angle (CR=5) | Right | 75 | 89 | - | | |
| θ _L | | Left | 75 | 89 | - | | |
| Φ _H | Vertical Viewing Angle (CR=5) | Up | 75 | 89 | - | | |
| Φ _L | | Down | 75 | 89 | - | | |
| T _R | Response Time | Rising Time | - | 13 | 28 | | [msec] Note 2-6 By TRD-100 |
| T _F | | Falling Time | - | 5 | 8 | | |
| - | | Rising + Falling | - | 18 | 36 | | |
| R _x | Color Coordinates (CIE 1931) | Red x | 0.622 | 0.652 | 0.682 | | By SR-3 |
| R _y | | Red y | 0.305 | 0.335 | 0.365 | | |
| G _x | | Green x | 0.291 | 0.321 | 0.351 | | |
| G _y | | Green y | 0.595 | 0.625 | 0.655 | | |
| B _x | | Blue x | 0.123 | 0.153 | 0.183 | | |
| B _y | | Blue y | 0.037 | 0.067 | 0.097 | | |
| W _x | | White x | 0.283 | 0.313 | 0.343 | | |
| W _y | | White y | 0.299 | 0.329 | 0.359 | | |
| NTSC Area Ratio | | | 72 | | [%] | By SR-3 | |
| CT | Crosstalk | - | - | 2.0 | [%] | Note 2-7 By SR-3 | |
| F _{dB} | Flicker (Center of screen) | - | - | -20 | [dB] | Note 2-8 By SR-3 | |



Note 2-2: Equipment setup :

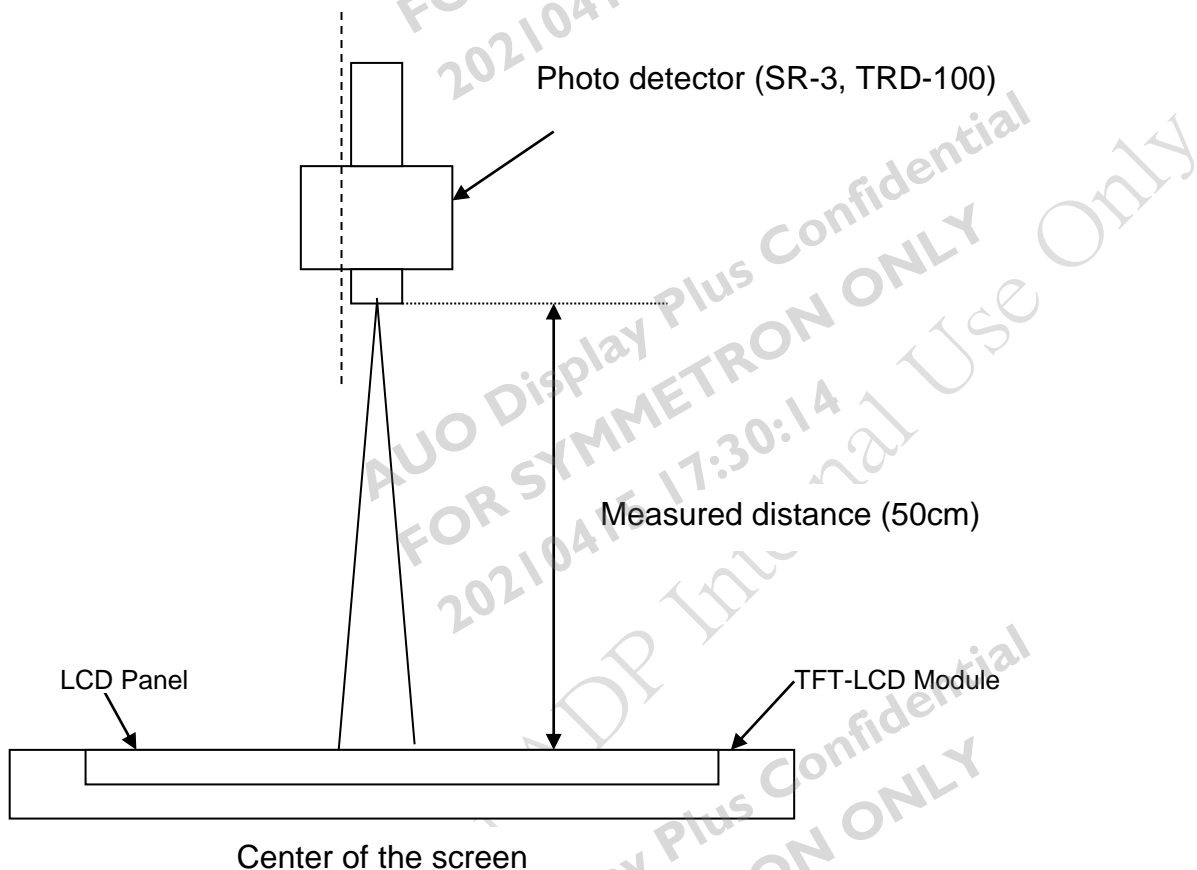

Note 2-3: Luminance Uniformity Measurement

Definition:

$$\text{Luminance Uniformity} = \frac{\text{Minimum Luminance of 9 Points (P1 ~ P9)}}{\text{Maximum Luminance of 9 Points (P1 ~ P9)}}$$

a. Test pattern: White Pattern

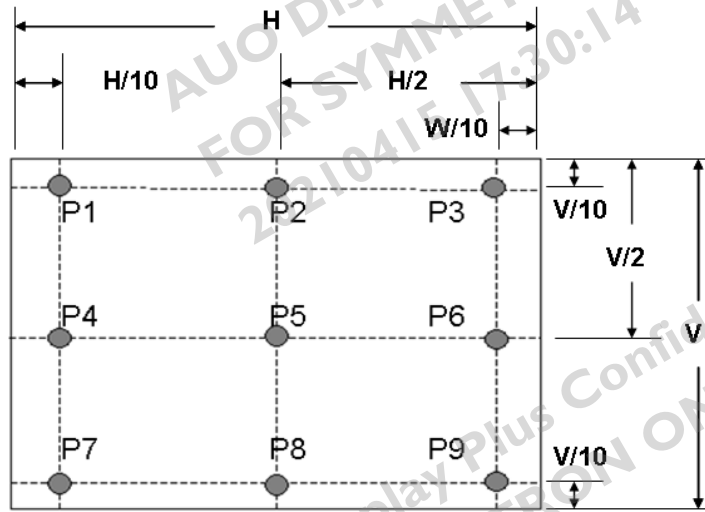

Note 2-4: Contrast Ratio Measurement

Definition:

$$\text{Contrast Ratio} = \frac{\text{Luminance of White pattern}}{\text{Luminance of Black pattern}}$$

- a. Measured position: Center of screen (P5) & perpendicular to the screen ($\theta = \Phi = 0^\circ$)

Note 2-5: Viewing angle measurement

Definition: The angle at which the contrast ratio is greater than 10 & 5 .

- a. Horizontal view angle: Divide to left & right (θ_L & θ_R)
Vertical view angle: Divide to up & down (Φ_H & Φ_L)

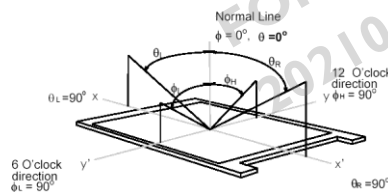

Note 2-6: Response time measurement



The output signals of photo detector are measured when the input signals are changed from “Black” to “White” (rising time, T_R), and from “White” to “Black” (falling time, T_F), respectively. The response time is interval between the 10% and 90% of optical response. (*Black & White color definition: Please refer section 3.4.3*)

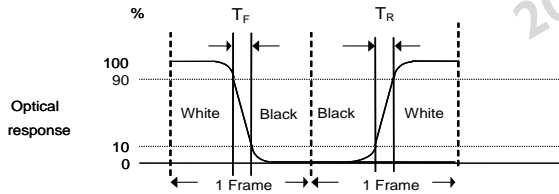

Note 2-7: Crosstalk measurement

Definition:

$CT = \text{Max. } (CT_H, CT_V);$

Where

a. Maximum Horizontal Crosstalk :

$CT_H = \text{Max. } (| Y_{BL} - Y_{AL} | / Y_{AL} \times 100 \%, | Y_{BR} - Y_{AR} | / Y_{AR} \times 100 \%);$

Maximum Vertical Crosstalk:

$CT_V = \text{Max. } (| Y_{BU} - Y_{AU} | / Y_{AU} \times 100 \%, | Y_{BD} - Y_{AD} | / Y_{AD} \times 100 \%);$

b. $Y_{AU}, Y_{AD}, Y_{AL}, Y_{AR}$ = Luminance of measured location without Black pattern

$Y_{BU}, Y_{BD}, Y_{BL}, Y_{BR}$ = Luminance of measured location with Black pattern

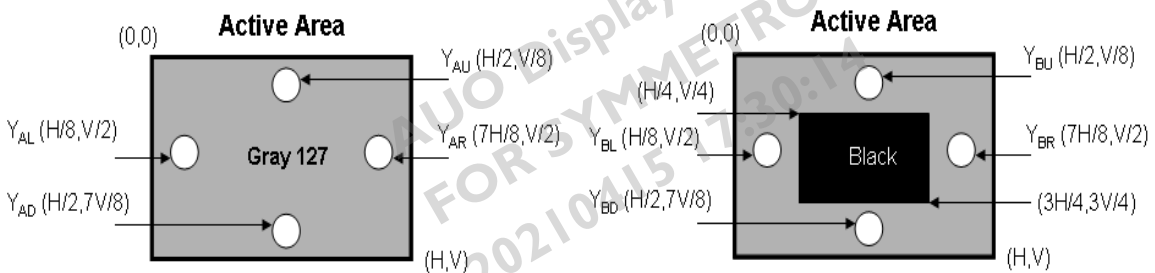

Note 2-8: Flicker measurement

a. Test pattern: It is listed as following.

Gray level = L0

Gray level = L127

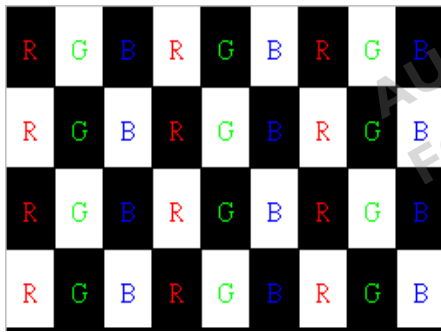

R: Red, G: Green, B:Blue

b. Measured position: Center of screen (P5) & perpendicular to the screen ($\theta=\Phi=0^\circ$)

2.4 Mechanical Characteristics

| Symbol | Description | Min. | Max. | Unit | Remark |
|-----------------|----------------------|------|------|-------|----------|
| P _{bc} | Backside Compression | 2.5 | - | [Kgf] | Note 2-9 |

Note 2-9: Test Method:

The point is at a distance from right-downside 25mm x 25mm defined as the Start Point of Measure Points, and the point is at a distance 25mm from left-side & around 10mm from PCB defined as the End Point.

Align 50mm x 50mm block from Start Point on the Bezel Back, and the corners of each block are Measure Points.

If the distance from the last block to each side of the End Point ≥ 25 mm, add other blocks to make sure that most area of Bezel Back can be measured.

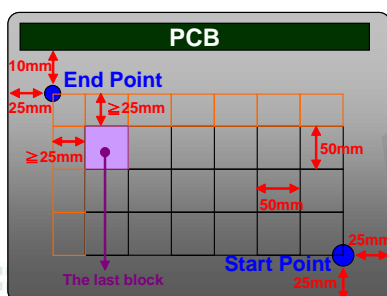



AUO Display Plus Confidential
FOR SYMMETRON ONLY
20210415 17:30:14

AUO Display Plus Confidential
FOR SYMMETRON ONLY
20210415 17:30:14

ADP Confidential for ADP Internal Use Only

AUO Display Plus Confidential
FOR SYMMETRON ONLY
20210415 17:30:14

AUO Display Plus Confidential
FOR SYMMETRON ONLY
20210415 17:30:14



3 TFT-LCD Module

3.1 Block Diagram

The following shows the block diagram of the 21.5 inch Color TFT-LCD Module.

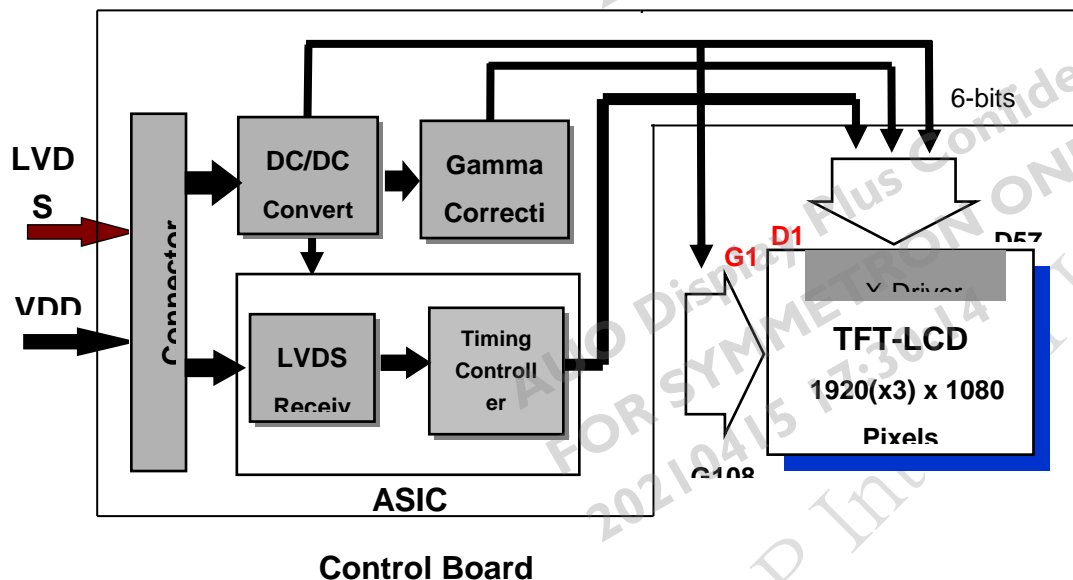



3.2 Interface Connection

3.2.1 Connector Type

| | | | |
|-------------------|--------------|------------------------|----------------|
| TFT-LCD Connector | Manufacturer | P-TWO | STM |
| | Part Number | AL230F-A0G1D-P | MSCKT2407P30HB |
| Mating Connector | Manufacturer | JAE | |
| | Part Number | FI-X30HL (Locked Type) | |

3.2.2 Connector Pin Assignment

| PIN # | Symbol | Description | Remark |
|-------|---------|---|--------|
| 1 | RxO0- | Negative LVDS differential data input (Odd data) | |
| 2 | RxO0+ | Positive LVDS differential data input (Odd data) | |
| 3 | RxO1- | Negative LVDS differential data input (Odd data) | |
| 4 | RxO1+ | Positive LVDS differential data input (Odd data) | |
| 5 | RxO2- | Negative LVDS differential data input (Odd data) | |
| 6 | RxO2+ | Positive LVDS differential data input (Odd data) | |
| 7 | GND | Ground | |
| 8 | RxOCLK- | Negative LVDS differential clock input (Odd clock) | |
| 9 | RxOCLK+ | Positive LVDS differential clock input (Odd clock) | |
| 10 | RxO3- | Negative LVDS differential data input (Odd data) | |
| 11 | RxO3+ | Positive LVDS differential data input (Odd data) | |
| 12 | RxE0- | Negative LVDS differential data input (Even data) | |
| 13 | RxE0+ | Positive LVDS differential data input (Even data) | |
| 14 | GND | Ground | |
| 15 | RxE1- | Negative LVDS differential data input (Even data) | |
| 16 | RxE1+ | Positive LVDS differential data input (Even data) | |
| 17 | GND | Ground | |
| 18 | RxE2- | Negative LVDS differential data input (Even data) | |
| 19 | RxE2+ | Positive LVDS differential data input (Even data) | |
| 20 | RxECLK- | Negative LVDS differential clock input (Even clock) | |
| 21 | RxECLK+ | Positive LVDS differential clock input (Even clock) | |
| 22 | RxE3- | Negative LVDS differential data input (Even data) | |
| 23 | RxE3+ | Positive LVDS differential data input (Even data) | |
| 24 | GND | Ground | |
| 25 | NC | No connection (for ADP test only. Do not connect) | |
| 26 | NC | No connection (for ADP test only. Do not connect) | |



| | | | |
|----|-----|---|--|
| 27 | NC | No connection (for ADP test only. Do not connect) | |
| 28 | VDD | Power Supply Input Voltage | |
| 29 | VDD | Power Supply Input Voltage | |
| 30 | VDD | Power Supply Input Voltage | |

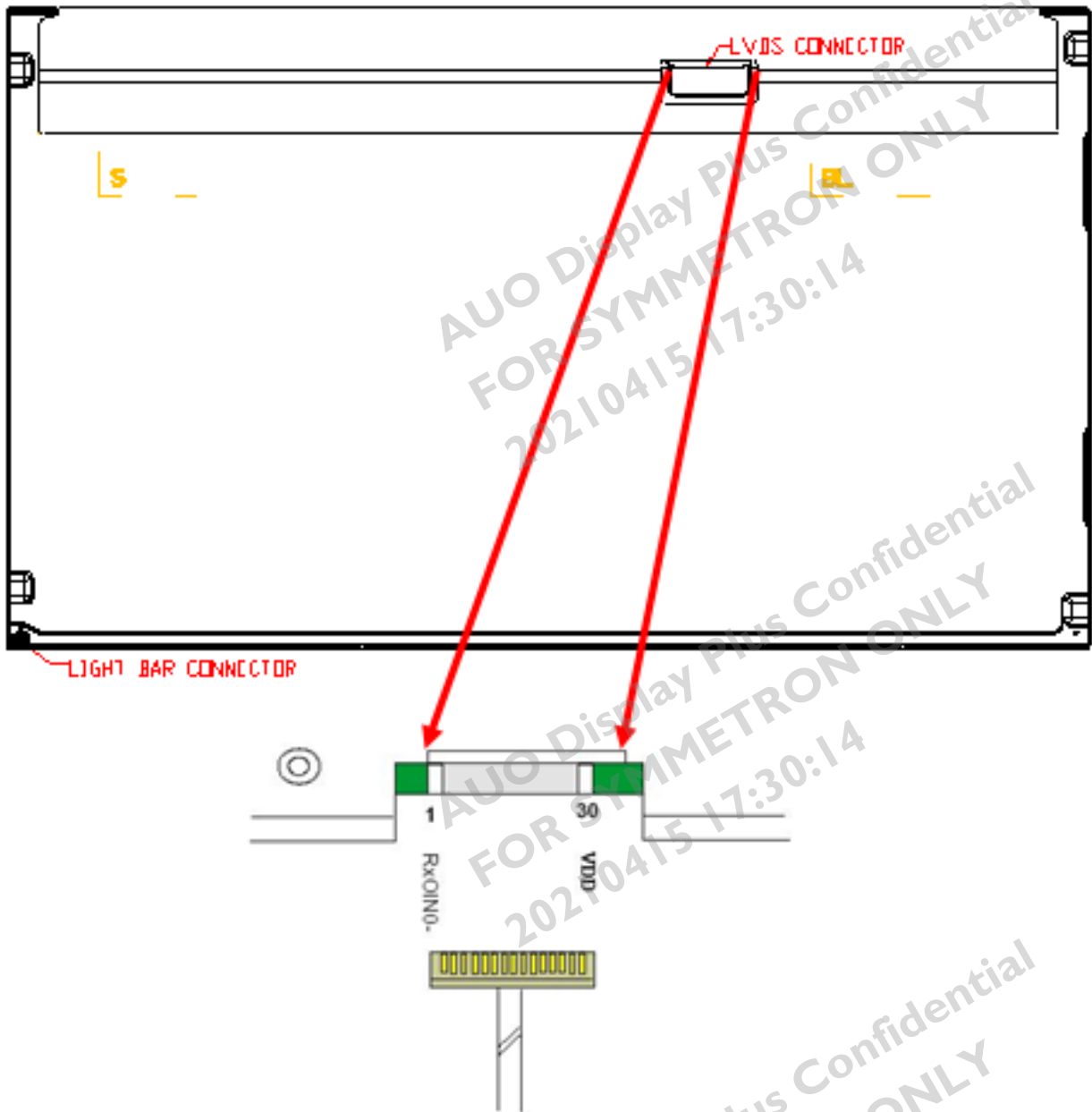



3.3 Electrical Characteristics

3.3.1 Absolute Maximum Rating

Permanent damage may occur if exceeding the following maximum rating.

| Symbol | Description | Min | Max | Unit | Remark |
|--------|----------------------------|---------|-----|--------|---------|
| VDD | Power Supply Input Voltage | GND-0.3 | 6.0 | [Volt] | Ta=25°C |

3.3.2 Recommended Operating Condition

| Symbol | Description | Min | Typ | Max | Unit | Remark |
|--------|----------------------------------|-----|------|------|--------|---------------------------------------|
| VDD | Power supply Input voltage | 4.5 | 5.0 | 5.5 | [Volt] | |
| IDD | Power supply Input Current (RMS) | - | 0.62 | 0.74 | [A] | VDD= 5.0V, All white Pattern, Fv=60Hz |
| | | | 0.7 | 0.84 | [A] | VDD= 5.0V, All white Pattern, Fv=75Hz |
| PDD | VDD Power Consumption | - | 3.1 | 3.7 | [Watt] | VDD= 5.0V, All white Pattern, Fv=60Hz |
| | | | 3.5 | 4.2 | [Watt] | VDD= 5.0V, All white Pattern, Fv=75Hz |
| IRush | Inrush Current | - | - | 3.0 | [A] | Note 3-1 |
| VDDrp | Allowable VDD Ripple Voltage | - | - | 500 | [mV] | VDD= 5.0V, All white Pattern, Fv=75Hz |

Note 3-1: Inrush Current measurement:

Test circuit:

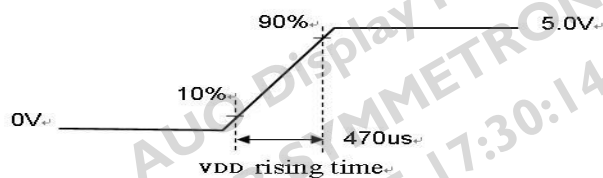
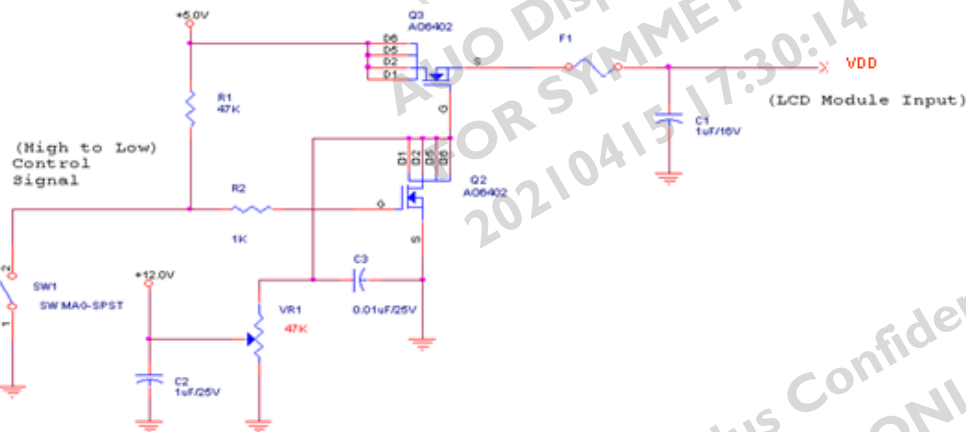

The duration of VDD rising time: 470us.



3.4 Signal Characteristics

3.4.1 LCD Pixel Format

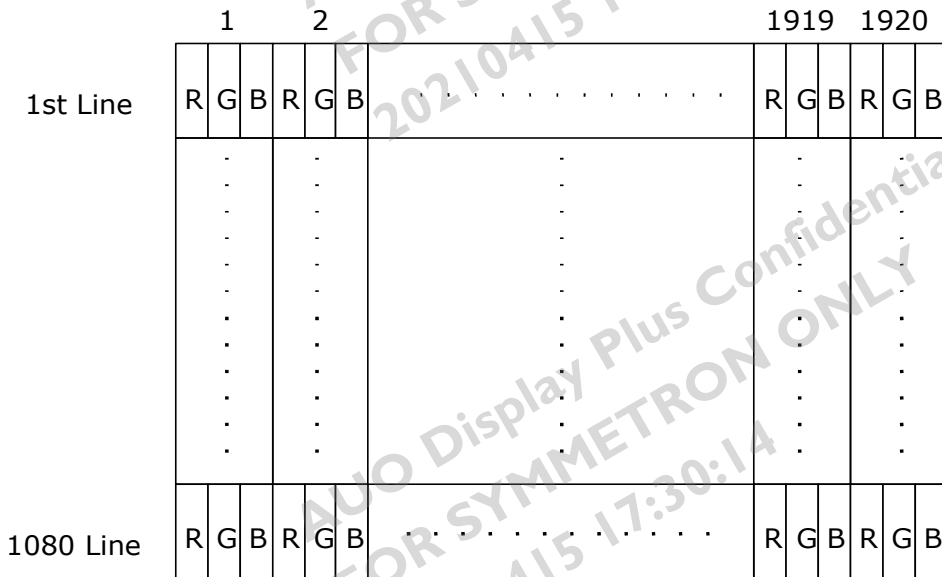

3.4.2 LVDS Data Format

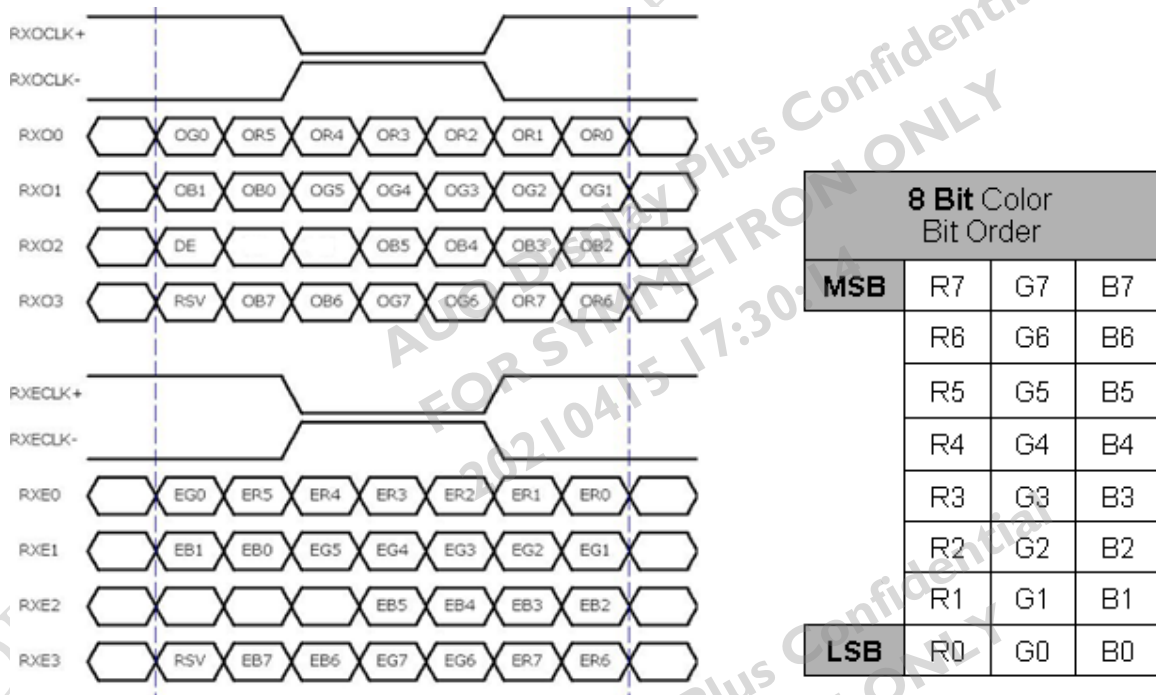

Note 3-2:

- a. O = "Odd Pixel Data" E = "Even Pixel Data"
- b. Refer to 3.4.1 LCD pixel format, the 1st data is 1 (Odd Pixel Data), the 2nd data is 2 (Even Pixel Data) and the last data is 1920 (Even Pixel Data).



3.4.3 Color versus Input Data

The following table is for color versus input data (8bit). The higher the gray level, the brighter the color.

| Color | Gray Level | Color Input Data | | | | | | | | | | | | | | | | | | | | | | | | Remark |
|----------|------------|------------------------------|----|----|----|----|----|----|----|--------------------------------|----|----|----|----|----|----|----|-------------------------------|----|----|----|----|----|----|----|--------|
| | | RED data (MSB:R7, LSB:R0) | | | | | | | | GREEN data (MSB:G7, LSB:G0) | | | | | | | | BLUE data (MSB:B7, LSB:B0) | | | | | | | | |
| | | R7 | R6 | R5 | R4 | R3 | R2 | R1 | R0 | G7 | G6 | G5 | G4 | G3 | G2 | G1 | G0 | B7 | B6 | B5 | B4 | B3 | B2 | B1 | B0 | |
| Black | - | 0 | 0 | 0 | 0 | 0 | 0 | 0 | 0 | 0 | 0 | 0 | 0 | 0 | 0 | 0 | 0 | 0 | 0 | 0 | 0 | 0 | 0 | 0 | 0 | |
| White | - | 1 | 1 | 1 | 1 | 1 | 1 | 1 | 1 | 1 | 1 | 1 | 1 | 1 | 1 | 1 | 1 | 1 | 1 | 1 | 1 | 1 | 1 | 1 | 1 | |
| Gray 127 | - | 0 | 1 | 1 | 1 | 1 | 1 | 1 | 1 | 0 | 1 | 1 | 1 | 1 | 1 | 1 | 1 | 0 | 1 | 1 | 1 | 1 | 1 | 1 | 1 | |
| Red | L0 | 0 | 0 | 0 | 0 | 0 | 0 | 0 | 0 | 0 | 0 | 0 | 0 | 0 | 0 | 0 | 0 | 0 | 0 | 0 | 0 | 0 | 0 | 0 | 0 | Black |
| | : | : | : | : | : | : | : | : | : | : | : | : | : | : | : | : | : | : | : | : | : | : | : | : | : | |
| | L255 | 1 | 1 | 1 | 1 | 1 | 1 | 1 | 1 | 0 | 0 | 0 | 0 | 0 | 0 | 0 | 0 | 0 | 0 | 0 | 0 | 0 | 0 | 0 | 0 | |
| Green | L0 | 0 | 0 | 0 | 0 | 0 | 0 | 0 | 0 | 0 | 0 | 0 | 0 | 0 | 0 | 0 | 0 | 0 | 0 | 0 | 0 | 0 | 0 | 0 | 0 | Black |
| | : | : | : | : | : | : | : | : | : | : | : | : | : | : | : | : | : | : | : | : | : | : | : | : | : | |
| | L255 | 0 | 0 | 0 | 0 | 0 | 0 | 0 | 0 | 1 | 1 | 1 | 1 | 1 | 1 | 1 | 1 | 0 | 0 | 0 | 0 | 0 | 0 | 0 | 0 | |
| Blue | L0 | 0 | 0 | 0 | 0 | 0 | 0 | 0 | 0 | 0 | 0 | 0 | 0 | 0 | 0 | 0 | 0 | 0 | 0 | 0 | 0 | 0 | 0 | 0 | 0 | Black |
| | : | : | : | : | : | : | : | : | : | : | : | : | : | : | : | : | : | : | : | : | : | : | : | : | : | |
| | L255 | 0 | 0 | 0 | 0 | 0 | 0 | 0 | 0 | 0 | 0 | 0 | 0 | 0 | 0 | 0 | 0 | 1 | 1 | 1 | 1 | 1 | 1 | 1 | 1 | |



3.4.4 LVDS Specification

a. DC Characteristics:

| Symbol | Description | Min | Typ | Max | Units | Condition |
|------------|--|------|------|------|-------|---------------------------|
| V_{TH} | LVDS Differential Input High Threshold | - | - | +100 | [mV] | $V_{CM} = 1.2V$ |
| V_{TL} | LVDS Differential Input Low Threshold | -100 | - | - | [mV] | $V_{CM} = 1.2V$ |
| $ V_{ID} $ | LVDS Differential Input Voltage | 100 | - | 600 | [mV] | |
| V_{CM} | LVDS Common Mode Voltage | +1.0 | +1.2 | +1.5 | [V] | $V_{TH} - V_{TL} = 200mV$ |

LVDS Signal Waveform:

Use RxOCLK- & RxOCLK+ as example.

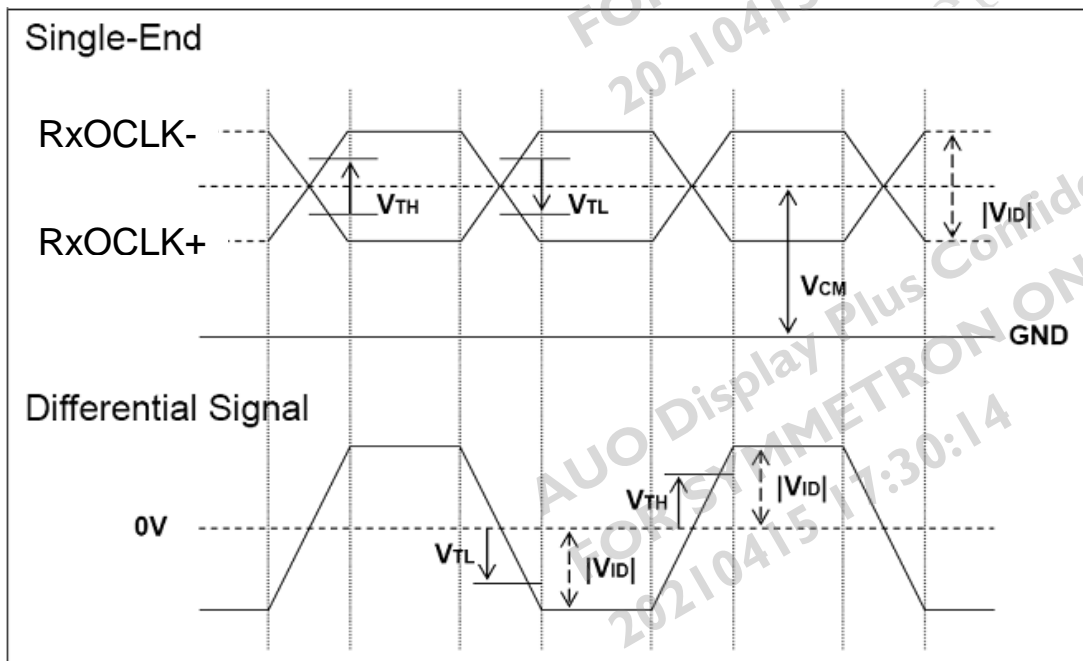



b. AC Characteristics:

| Symbol | Description | Min | Max | Unit | Remark |
|-----------|--|-----|---------|------|--------|
| F_{DEV} | Maximum deviation of input clock frequency during Spread Spectrum | - | ± 3 | % | |
| F_{MOD} | Maximum modulation frequency of input clock during Spread Spectrum | - | 200 | KHz | |

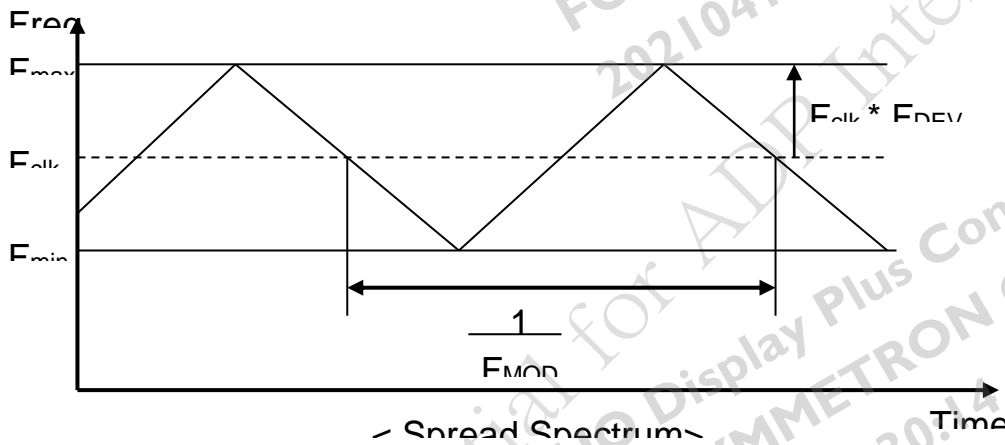

Fclk: LVDS Clock Frequency



3.4.5 Input Timing Specification

It only support DE mode, and the input timing are shown as the following table.

| Symbol | Description | | Min. | Typ. | Max. | Unit | Remark |
|-----------|--------------------|-----------|------|------|------|------|-----------|
| Tv | Vertical Section | Period | 1092 | 1130 | 1793 | Th | Tv |
| Tdisp (v) | | Active | 1080 | 1080 | 1080 | Th | Tdisp (v) |
| Tblk (v) | | Blanking | 12 | 50 | 713 | Th | Tblk (v) |
| Fv | | Frequency | 50 | 60 | 76 | Hz | Fv |
| Th | Horizontal Section | Period | 1004 | 1050 | 1100 | Tclk | Th |
| Tdisp (h) | | Active | 960 | 960 | 960 | Tclk | Tdisp (h) |
| Tblk (h) | | Blanking | 44 | 90 | 140 | Tclk | Tblk (h) |
| Fh | | Frequency | 55 | 68 | 90 | KHz | Fh |
| Tclk | LVDS Clock | Period | 11.1 | 14.0 | 18.2 | ns | Tclk |
| Fclk | | Frequency | 54.8 | 71.2 | 90.0 | MHz | Fclk |

Note 3-3: The equation is listed as following. Please don't exceed the above recommended value.

$$\begin{aligned} Fh (\text{Min.}) &= Fclk (\text{Min.}) / Th (\text{Min.}); \\ Fh (\text{Typ.}) &= Fclk (\text{Typ.}) / Th (\text{Typ.}); \\ Fh (\text{Max.}) &= Fclk (\text{Max.}) / Th (\text{Min.}); \end{aligned}$$

Note 3-4: The equation is listed as following. Please don't exceed the above recommended value.

$$\begin{aligned} Fclk (\text{Min.}) &= Fv (\text{Min.}) \times Th (\text{Min.}) \times Tv (\text{Min.}); \\ Fclk (\text{Typ.}) &= Fv (\text{Typ.}) \times Th (\text{Typ.}) \times Tv (\text{Typ.}); \\ Fclk (\text{Max.}) &= Fv (\text{Max.}) \times Th (\text{Typ.}) \times Tv (\text{Typ.}); \end{aligned}$$



3.4.6 Input Timing Diagram

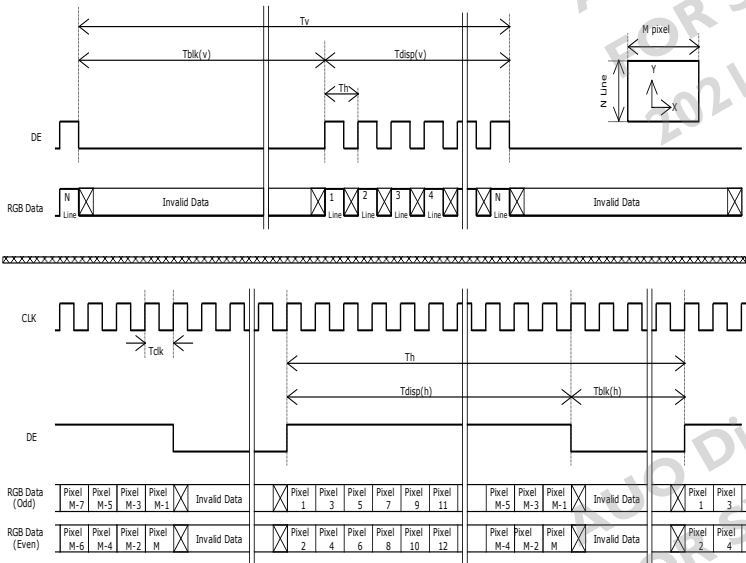



3.5 Power ON/OFF Sequence

VDD power, LVDS signal and backlight on/off sequence are as following. LVDS signals from any system shall be Hi-Z state when VDD is off.

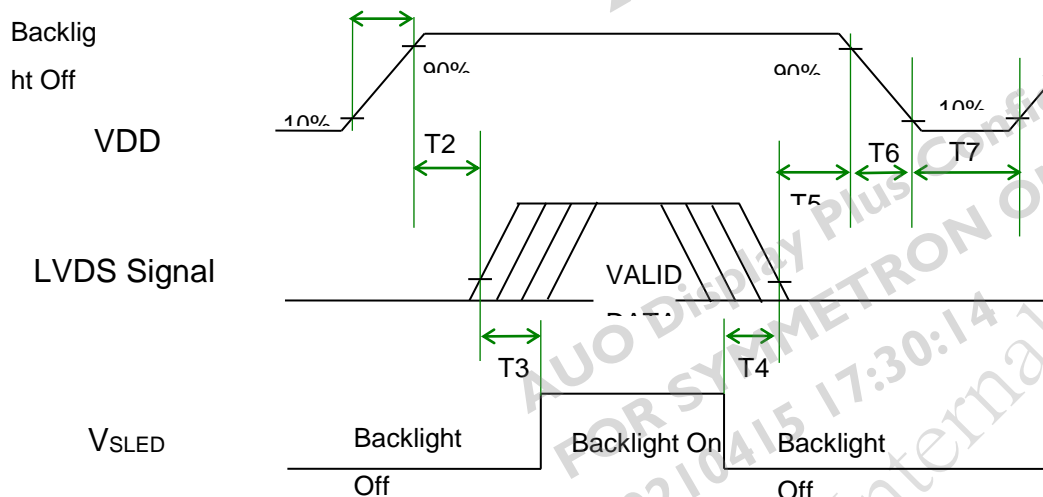

Power Sequence Timing

| Symbol | Value | | | Unit | Remark |
|--------|-------|------|------|------|------------------------------------|
| | Min. | Typ. | Max. | | |
| T1 | 0.5 | - | 10 | [ms] | |
| T2 | 0 | - | 50 | [ms] | |
| T3 | 500 | - | - | [ms] | |
| T4 | 100 | - | - | [ms] | |
| T5 | 0 | - | 50 | [ms] | Note 3-5 Note 3-6 |
| T6 | 0 | - | 200 | [ms] | Note 3-7 |
| T7 | 1000 | - | - | [ms] | |

Note 3-5 : Recommend setting T5 = 0ms to avoid electronic noise when VDD is off.

Note 3-6 : During T5 and T6 period , please keep the level of input LVDS signals with Hi-Z state.

Note 3-7 : Voltage of VDD must decay smoothly after power-off. (customer system decide this value)



AUO Display Plus Confidential
FOR SYMMETRON ONLY
20210415 17:30:14

AUO Display Plus Confidential
FOR SYMMETRON ONLY
20210415 17:30:14

ADP Confidential for ADP Internal Use Only

AUO Display Plus Confidential
FOR SYMMETRON ONLY
20210415 17:30:14

AUO Display Plus Confidential
FOR SYMMETRON ONLY
20210415 17:30:14





4 Backlight Unit

4.1 Block Diagram

The following shows the block diagram of the 21.5 inch Backlight Unit. And it includes 60 pcs LED in the LED light bar. (4 strings and 15 pcs LED of one string).

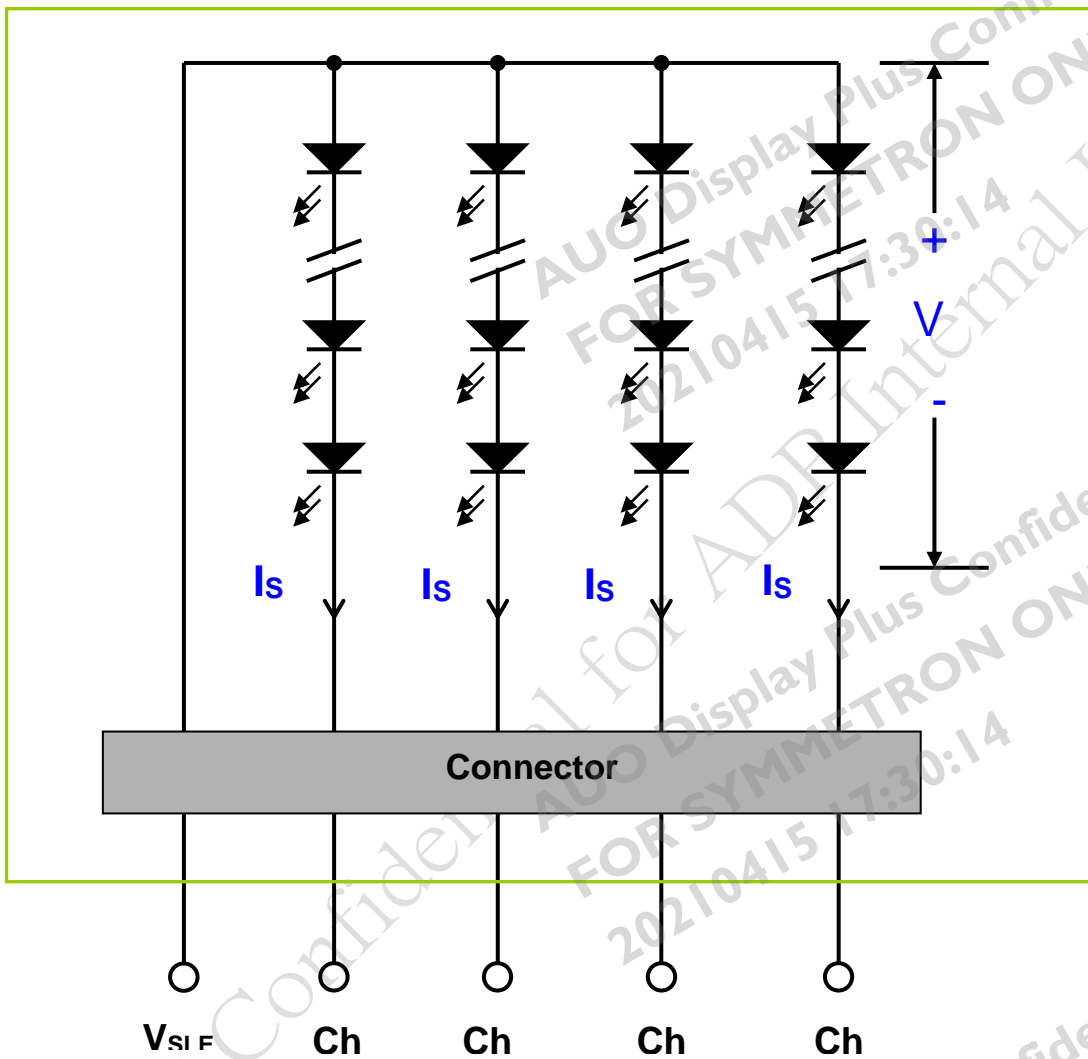



4.2 Interface Connection

4.2.1 Connector Type

| | | |
|---------------------|--------------|--|
| Backlight Connector | Manufacturer | ENTERY |
| | Part Number | 3707K-S06N-21R |
| Mating Connector | Manufacturer | ENTERY |
| | Part Number | H112K-P06N-00B (Non-Locking type) H112K-P06N-03B (Locking type) |

Backlight Connector dimension:

$H \times V \times D = 13.9 \times 3.00 \times 4.25$, Pitch = 1.0 (unit = mm)

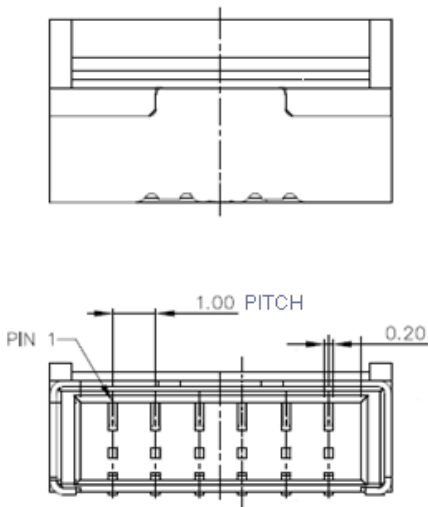



Mating Connector dimension:

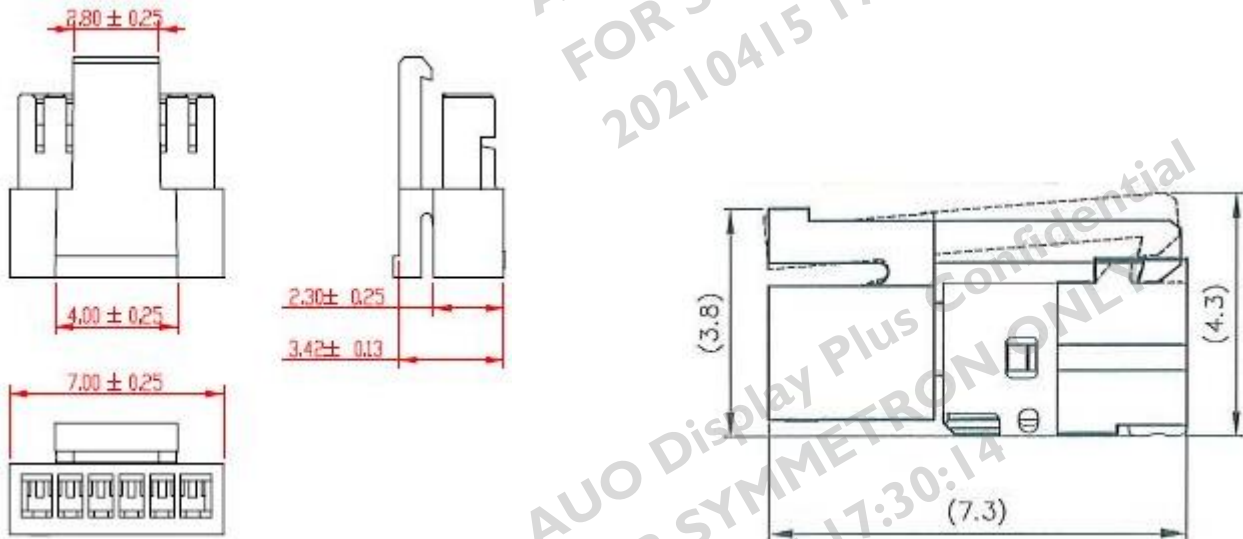



4.2.2 Connector Pin Assignment

| Pin# | Symbol | Description | Remark |
|------|--------|---|--------|
| 1 | Ch1 | LED Current Feedback Terminal (Channel 1) | |
| 2 | Ch2 | LED Current Feedback Terminal (Channel 2) | |
| 3 | VSLED | LED Power Supply Voltage Input Terminal | |
| 4 | VSLED | LED Power Supply Voltage Input Terminal | |
| 5 | Ch3 | LED Current Feedback Terminal (Channel 3) | |
| 6 | Ch4 | LED Current Feedback Terminal (Channel 4) | |

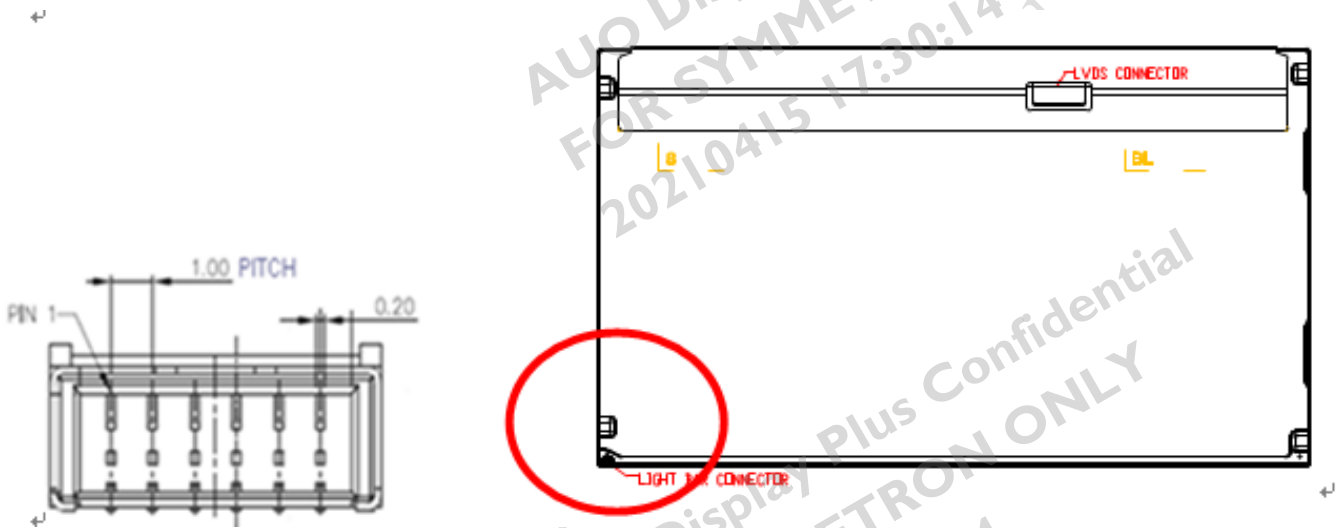



4.3 Electrical Characteristics

4.3.1 Absolute Maximum Rating

Permanent damage may occur if exceeding the following maximum rating.

(Ta=25°C)

| Symbol | Description | Min | Max | Unit | Remark |
|--------|--------------------|-----|-----|------|--------------------------------------|
| Is | LED String Current | 0 | 90 | [mA] | 100% duty ratio |
| | | | 150 | [mA] | Duty ratio ≤ 10% Pulse time=10 ms |

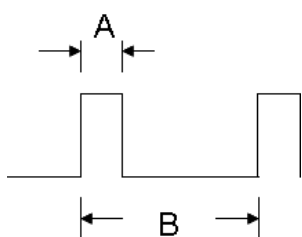

Duty ratio= (A / B) X 100% ; (A: Pulse time, B: Period)

4.3.2 Recommended Operating Condition

(Ta=25°C)

| Symbol | Description | Min. | Typ. | Max. | Unit | Remark |
|-------------------|---|------------|------|------|--------|--|
| Is | LED String Current | - | 60 | 66 | [mA] | 100% duty ratio of LED chip <i>Note 4-6</i> |
| Vs | LED String Voltage | - | 46.5 | 51 | [Volt] | Is=60mA @ 100% duty ratio; Note 4-1, Note 4-5, Note 4-7 |
| ΔVs | Maximum Vs Voltage Deviation of light bar | - | - | 3 | [Volt] | Is=60mA @ 100% duty ratio; Note 4-2 |
| P _{BLU} | LED Light Bar Power Consumption | - | 11.2 | 12.2 | [Watt] | Note 4-3 |
| LT _{LED} | LED Life Time | 30,000 | - | - | [Hour] | Note 4-4 |
| OVP | Over Voltage Protection in system board | 110% Vsmax | - | - | [Volt] | Note 4-5 |



- Note 4-1:** $V_s (\text{Typ.}) = V_F (\text{Typ.}) \times \text{LED No. (one string)}$;
- V_F : LED chip forward voltage, $V_F (\text{Min.}) = 2.8\text{V}$, $V_F (\text{Typ.}) = 3.1\text{V}$, $V_F (\text{Max.}) = 3.4\text{V}$
 - The same equation to calculate $V_s (\text{Min.})$ & $V_s (\text{Max.})$ for respective $V_F (\text{Min.})$ & $V_F (\text{Max.})$;

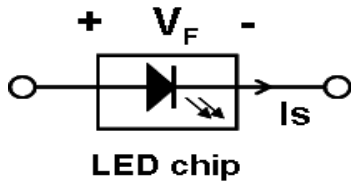

- Note 4-2:** $\Delta V_s (\text{Max.}) = \Delta V_F \times \text{LED No. (one string)}$;
- ΔV_F : LED chip forward voltage deviation; (0.2 V , each Bin of LED V_F)
- Note 4-3:** $P_{\text{BLU}} (\text{Typ.}) = V_s (\text{Typ.}) \times I_s (\text{Typ.}) \times 4$; (4 is total String No. of LED Light bar)
- $P_{\text{BLU}} (\text{Max.}) = V_s (\text{Max.}) \times I_s (\text{Typ.}) \times 4$;

- Note 4-4:** Definition of life time:
- Brightness of LED becomes to 50% of its original value
 - Test condition: $I_s = 60\text{mA}$ and 25°C (Room Temperature)

- Note 4-5:** Recommendation for LED driver power design:
Due to there are electrical property deviation in LED & monitor set system component after long time operation. ADP strongly recommend the design value of LED driver board OVP (over voltage protection) should be 10% higher than max. value of LED string voltage (V_s) at least.

- Note 4-6:** ADP strongly recommend “Analog Dimming” method for backlight brightness control for Wavy Noise Free. Otherwise, recommend that Dimming Control Signal (PWM Signal) should be synchronized with Frame Frequency.

- Note 4-7:** Ensure that the LED light bar is not subjected either forward or reverse voltage while monitor set is on standby mode or not in use.



5 Reliability Test

ADP reliability test items are listed as following table. (*Bare Panel only*)

| Items | Condition | Remark |
|-----------------------------------|---|-----------------|
| Temperature Humidity Bias (THB) | Ta= 50°C, 80%RH, 300hours | |
| High Temperature Operation (HTO) | Ta= 50°C, 50%RH, 300hours | |
| Low Temperature Operation (LTO) | Ta= 0°C, 300hours | |
| High Temperature Storage (HTS) | Ta= 60°C, 300hours | |
| Low Temperature Storage (LTS) | Ta= -20°C, 300hours | |
| Vibration Test (Non-operation) | Acceleration: 1.5 Grms Wave: Random Frequency: 10 - 200 Hz Sweep: 30 Minutes each Axis (X, Y, Z) | |
| Shock Test (Non-operation) | Acceleration: 50 G Wave: Half-sine Active Time: 20 ms Direction: ±X, ±Y, ±Z (one time for each Axis) | |
| Thermal Shock Test (TST) | -20°C/30min, 60°C/30min, 100 cycles | Note 5-1 |
| On/Off Test | On/10sec, Off/10sec, 30,000 cycles | |
| ESD (Electro Static Discharge) | Contact Discharge: ± 15KV, 150pF(330Ω) 1sec, 8 points, 25 times/ point. | Note 5-2 |
| | Air Discharge: ± 15KV, 150pF(330Ω) 1sec 8 points, 25 times/ point. | |
| Altitude Test | Operation:18,000 ft Non-Operation:40,000 ft | |

Note 5-1: a. A cycle of rapid temperature change consists of varying the temperature from -20°C to 60°C and back again. Power is not applied during the test.
b. After finish temperature cycling, the unit is placed in normal room ambient for at least 4 hours before power on.

Note 5-2: EN61000-4-2, ESD class B: Certain performance degradation allowed
No data lost
Self-recoverable
No hardware failures.



6 Shipping Label

The label is on the panel as shown below:

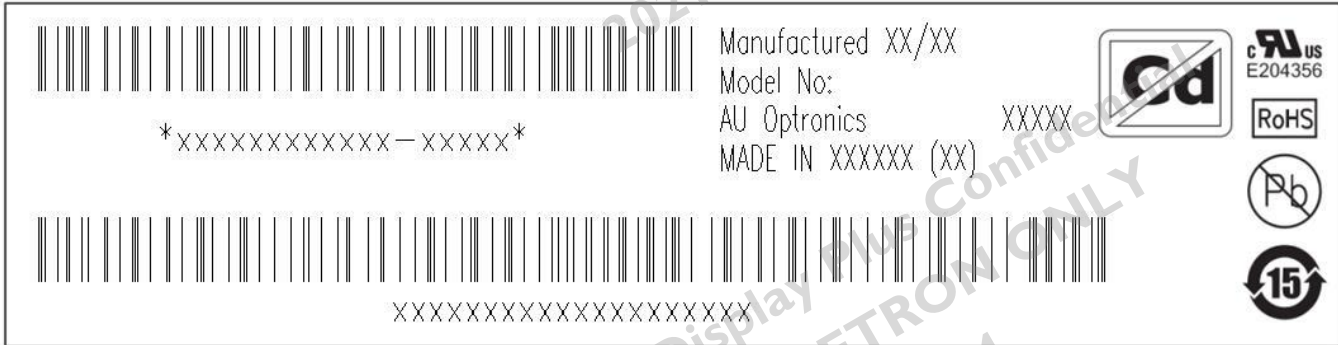

Note 6-1: For Pb Free products, ADP will add  for identification.

Note 6-2: For RoHS compatible products, ADP will add  for identification.

Note 6-3: For China RoHS compatible products, ADP will add  for identification.

Note 6-4: For "Cadmium Free product, ADP will add  for identification.

Note 6-5: The Green Mark will be presented only when the green documents have been ready by ADP Internal Green Team.

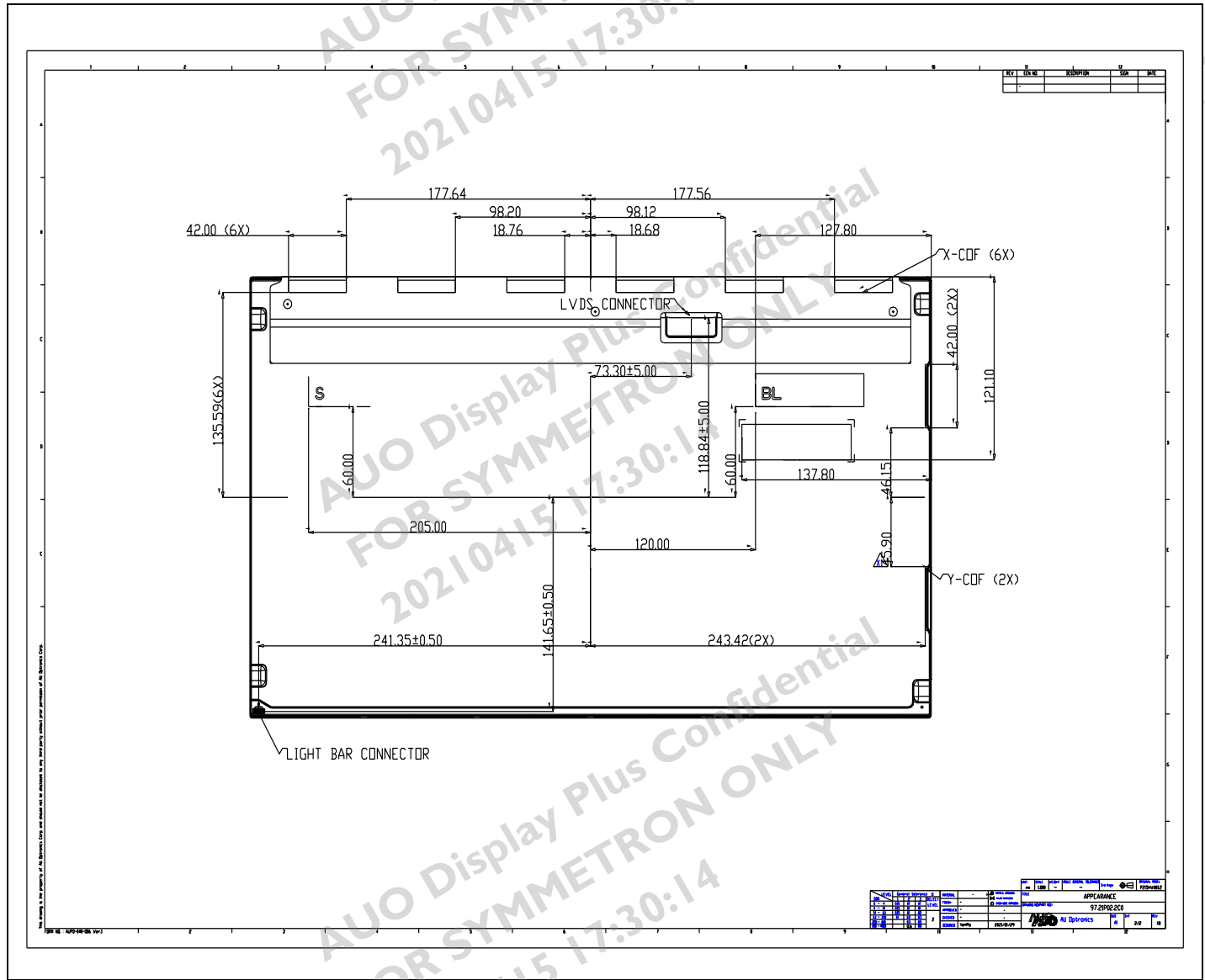

8 Packing Specification

8.1 Packing Flow

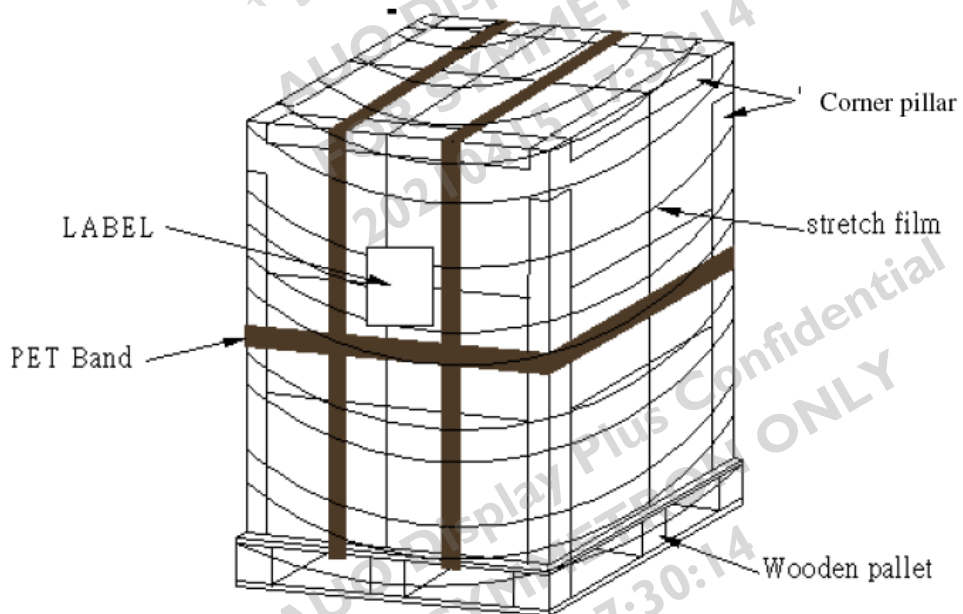
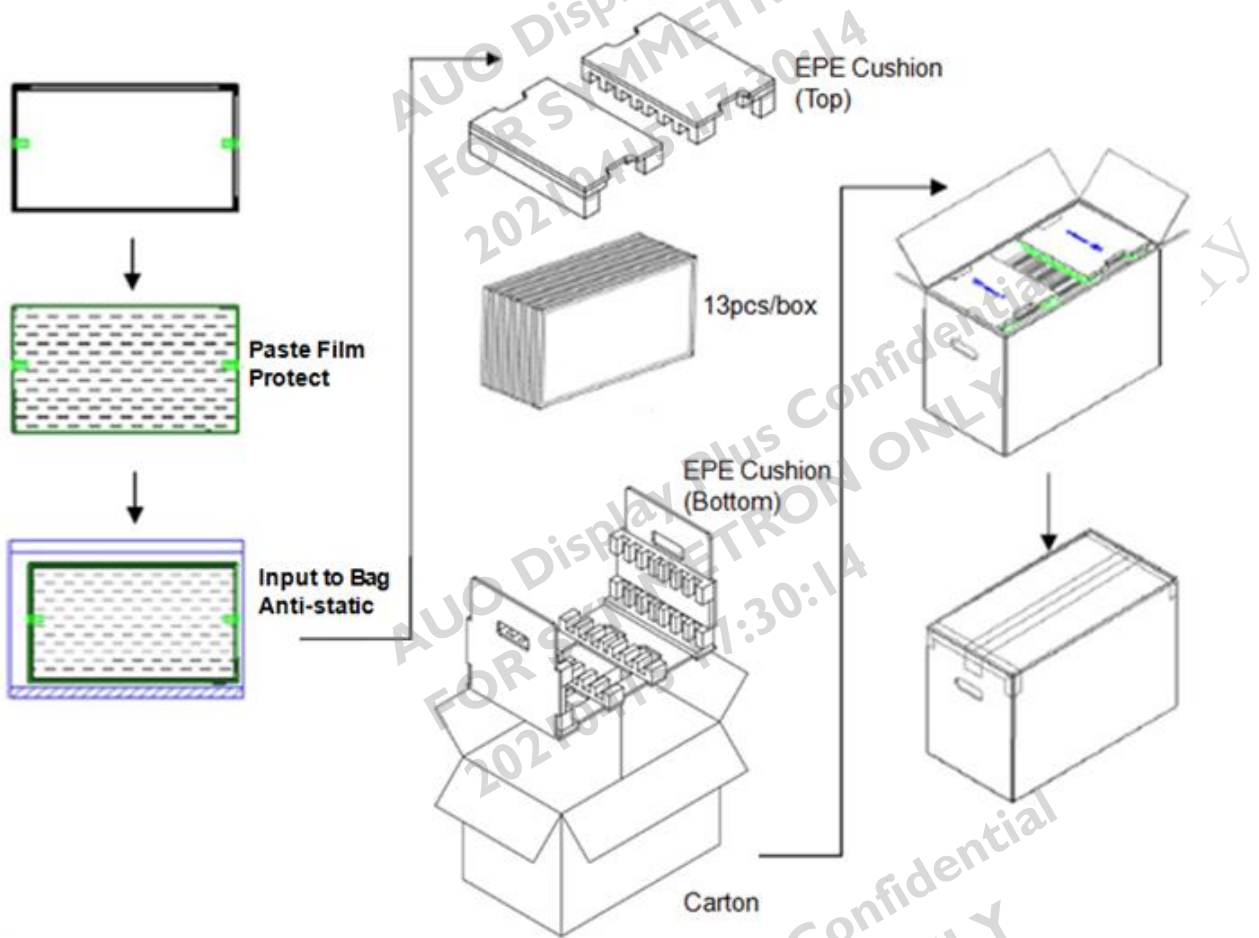

Single pallet stack Illustration

8.2 Pallet and shipment information

| | Item | Specification | | | Remark |
|---|----------------------|----------------|-------------------------------------|------------|--|
| | | Q'ty | Dimension | Weight(kg) | |
| 1 | Panel | 1 | 495.6(H)mm x 292.2(V)mm x 10.6(D)mm | 1.67 | Note 1 |
| 2 | Cushion | 1 | -- | 0.56 | |
| 3 | Box | 1 | 565(L)mm x 345(W)mm x 375(H)mm | 1.4 | without Panel & cushion Note 1 |
| 4 | Packing Box | 13 pcs/Box | 565(L)mm x 345(W)mm x 375(H)mm | 24 | with panel & cushion Note 1 |
| 5 | Pallet | 1 | 1150(L)mm x 1070(W)mm x 132(H)mm | 12 | Note 1 |
| 6 | Pallet after Packing | 18boxes/pallet | 1150(L)mm x 1070(W)mm x 1257(H)mm | 432 | Note 1 |

Note 1: Estimated value which is subject to change based on real measured data.