

FEATURES

1. Universal AC input 85~264VAC
2. Protections: Short circuit /Overload /Over voltage
3. Can be installed on DIN rail TS-35/7.5 or 15
4. Isolation class II
5. LED indicator for power on
6. High reliability
7. 3 years warranty
8. Compliance to IEC/EN/UL 62368-1



3 years
Warranty

Specification

MODEL		RAI75-05-PR2	RAI75-12-PR2	RAI75-15-PR2	RAI75-24-PR2	RAI75-36-PR2	RAI75-48-PR2
INPUT	VOLTAGE RANGE	85~264VAC 120-370VDC (Refer to "Static characteristics")					
	FREQUENCY RANGE	47~63Hz					
	EFFICIENCY(Typ.)	85%	88%	88%	90%	90%	91%
	AC CURRENT(Typ.)	1.7A/115VAC 0.9A/230VAC					
	INRUSH CURRENT(Typ.)	30A/115VAC 60A/230VAC (cold start)					
OUTPUT	DC VOLTAGE	5V	12V	15V	24V	36V	48V
	RATED CURRENT	8A	5A	4A	3.14A	2.08A	1.57A
	CURRENT RANGE	0~8A	0~5A	0~4A	0~3.14A	0~2.08A	0~1.57A
	RATED POWER	40W	60W	60W	75.36W	74.88W	75.36W
	RIPPLE&NOISE(max.)	100mVp-p	100mVp-p	100mVp-p	100mVp-p	100mVp-p	100mVp-p
	VOLTAGE ADJ.RANGE	5~5.5V	10.8~13.8V	13.5~18V	21.6~28.8V	32.4~43.2V	43.2~57.6V
	VOLTAGE TOLERANCE	±2%	±1%	±1%	±1%	±1%	±1%
	LINE REGULATION	±1%	±0.5%	±0.5%	±0.5%	±0.5%	±0.5%
	LOAD REGULATION	±2%	±1%	±1%	±1%	±1%	±1%
	SETUP, RISE TIME	500ms,50ms/230VAC 500ms,50ms/115VAC					
	HOLD UP TIME(Typ.)	30ms/230VAC 7ms/115VAC					
PROTECTION	OVER LOAD	105%~160%rated output power Protection type: hiccup mode, recovers automatically after fault condition removed					
	OVER VOLTAGE	5.75~6.75V	15~18V	20~25V	30~36V	45~50V	60~66V
		Protection type: Shunt down, recovers after repower on					
ENVIRONMENT	WORKING TEMP, HUMIDITY	-40~+70°C(Refer to "Derating curve"),20~90%RH non-condensing					
	STORAGE TEMP., HUMIDITY	-40~+85°C,10~95%RH					
	TEMP.COEFFICIENT	±0.03%/°C(0~50°C)					
	VIBRATION	10~500Hz,2G 10min./1 cycle, each along X、Y、Z axes					

Safety and electromagnetic compatibility	Safety standards	Refer to UL62368-1, TUV EN62368-1, CCC GB4943.1		
	Withstand voltage and isolation resistance	I/P-O/P:4KVac;100M Ω /500Vdc/25°C/70%RH		
		Parameter	Standard	Test Level /Note
	Electromagnetic compatibility emission	Conducted emission	BS EN/EN55032(CISPR32),FCC PART 15/CISPR22 ,GB9254.1	Class B
		Radiated emission	BS EN/EN55032(CISPR32),FCC PART 15/CISPR22 ,GB9254.1	Class B
		Harmonic current	BS EN/EN61000-3-2,GB17625.1	Class A
		Voltage flicker	BS EN/EN61000-3-3	
	Electromagnetic compatibility immunity	BS EN/EN55035		
		Parameter	Standard	Test Level /Note
		ESD	BS EN/EN61000-4-2	Level 4,8KV air, Level 2,4KV contact, criteria A
		RF field susceptibility	BS EN/EN61000-4-3	Level 3,criteria A
		EFT bursts	BS EN/EN61000-4-4	Level 3,criteria A
		Surge susceptibility	BS EN/EN61000-4-5	Level 3,1KV/L-N criteria A
Conducted susceptibility		BS EN/EN61000-4-6	Level 3,criteria A	
Magnetic field immunity		BS EN/EN61000-4-8	Level 4,criteria A	
Voltage dips and interruptions	BS EN/EN61000-4-11	>95%dip 0.5 periods,30%dip 25 periods,>95%interruptions 250 periods		
OTHERS	MTBF	≥ 1000 Khrs MIL-HDBK-217F(25°C)		
	DIMENSION	17.5*90*54.5mm(W*H*D)		
	PACKING	0.08Kg;180pcs/15.4Kg/1.1CUFT		
NOTE	<p>1.All parameters NOT specially mentioned are measured at 230VAC input, rated load and 25°C of ambient temperature.</p> <p>2.Ripple & noise are measured at 20MHz of bandwidth by using a 12" twisted pair-wire terminated with a 0.1uF & 47uF parallel capacitor.</p> <p>3.Tolerance: includes set up tolerance, line regulation and load regulation.</p> <p>4.Line regulation is measured from low line to high line at rated load.</p> <p>5.Load regulation is measured from 0% to 100% rated load</p> <p>6.Length of set up time is measured at cold first start, Turning ON/OFF the power supply very quickly may lead to increase of the set up time.</p> <p>7.The ambient temperature derating of 5°C/1000m is needed for operating altitude great than 2000m(6500ft).</p> <p>8.The power supply is considered a component which will be installed into a final equipment. All the EMC tests are been executed by mounting the unit on a 360mm*360mm metal plate with 1mm of thickness. The final equipment must be re-confirmed that it still meets EMC directives.</p> <p>9.Installation clearances:40mm on top,20mm on the bottom,5mm on the left and right side are recommended when loaded permanently with full power. In case the adjacent device is a heat source,15mm clearance is recommended.</p>			

Mechanical specification

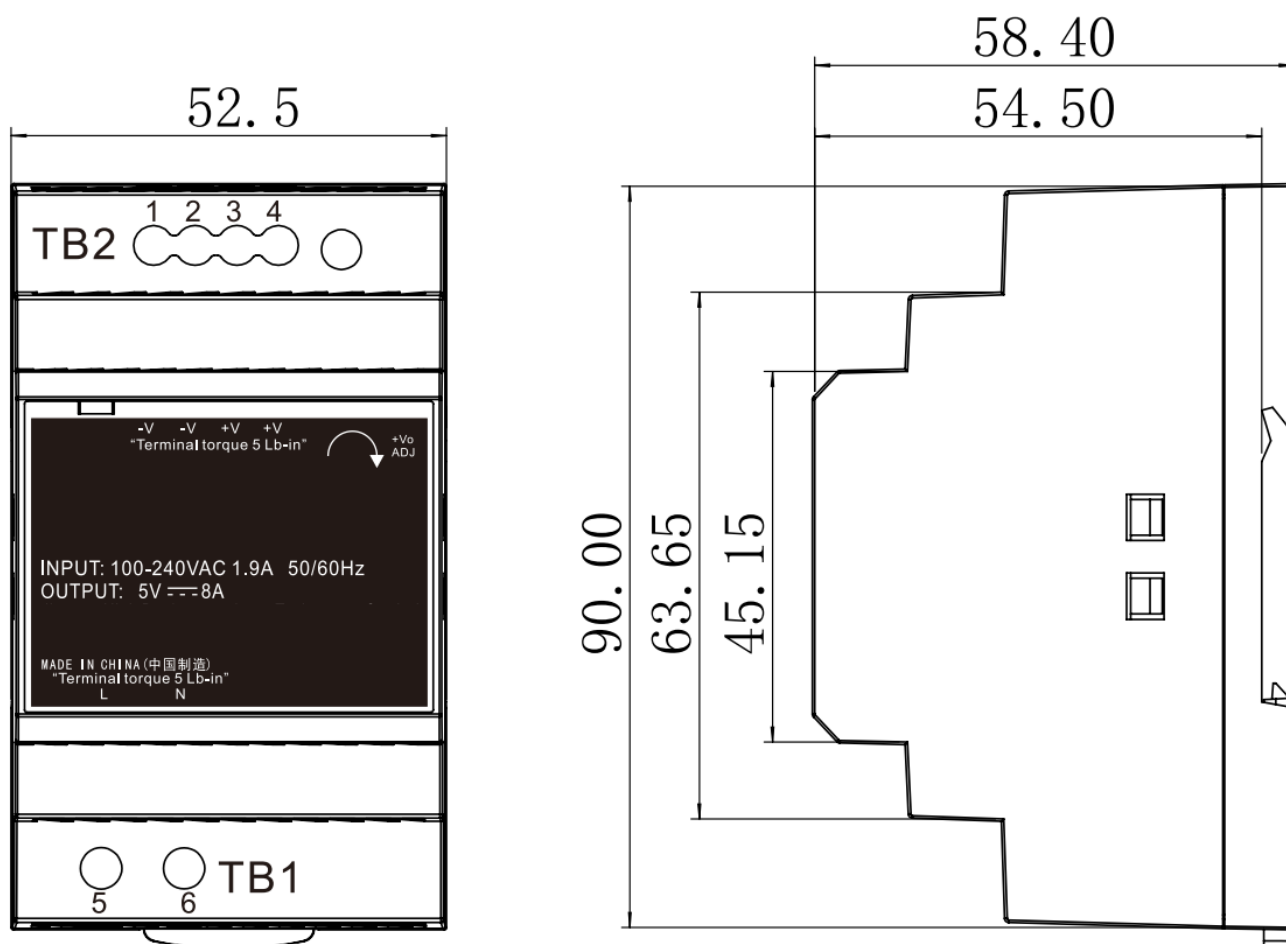

ADMISSIBLE DIN-RAIL: TS35/7.5 OR TS35/15
Terminal Pin No. Assignment

TB1		TB2	
Pin No.	Assignment	Pin No.	Assignment
5	AC/L	1,2	DC output -V
6	AC/N	3,4	DC output +V

NOTE:
Unit: mm
ADJ: Output adjustable resistor
TOL: ±1.00

Block diagram

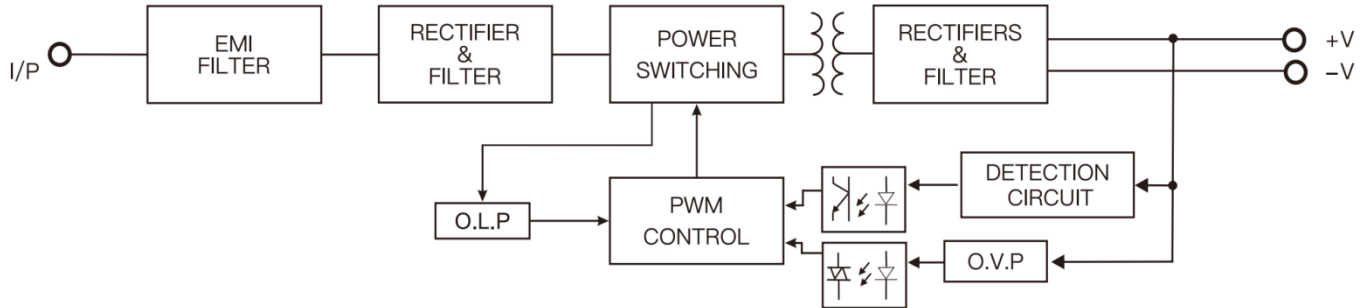

Derating curve

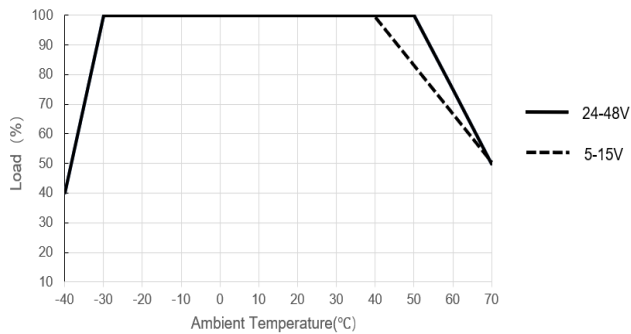

Static characteristics

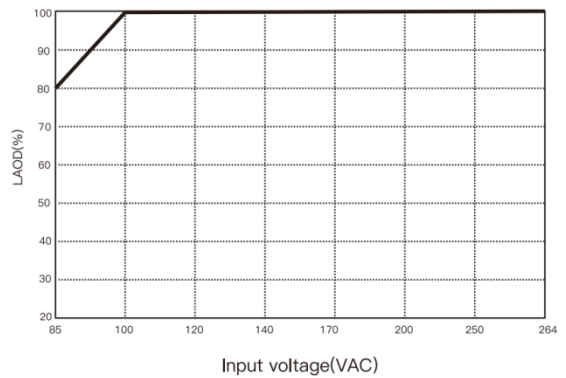

NORPAS-POWER TECHNOLOGY CO., LTD.

www.norpas-power.com Mail: info@norpas-power.com

Specifications can be changed without notice! Make sure you are using the latest documentation, downloadable at www.norpas-power.com

REV:07/2024