

SPECIFICATION

[] Preliminary Specification
[●] Final Specification

Description **15.6” 1920xRGBx1080 TFT-LCD Module**
Part Number **P1560FHF1MB00**

Customer	Industrial Product Dept, PDBU Tianma Microelectronics Co., Ltd.		
Signatures	Date	Approved By	Date
_____	_____	Zhu Guanchen	2023-6-27
_____	_____	Reviewed By	
		Zhu Guanchen	2023-6-27
		Prepared By	
		Wang Fang	2023-6-14
Comments:			

* This cover page is for your Comments and Signatures back to TIANMA.

REVISION HISTORY

Rev	Date	Page	Revision Items	Editor
1.0	2022-4-10	-	Preliminary spec	Wang Fang
2.0	2023-6-14	-	Final spec	Wang Fang

CONTENTS

1. SUMMARY.....	1
1.1 General Description.....	1
1.2 Features.....	1
2. GENERAL SPECIFICATIONS.....	2
3. INPUT / OUTPUT TERMINALS.....	3
3.1 CN1 Pin assignment (LCD Interface).....	3
3.2 CN2 Pin assignment (Back Light).....	4
3.3 Positions of Socket.....	4
4. ABSOLUTE MAXIMUM RATINGS	5
5. ELECTRICAL CHARACTERISTICS	6
5.1 DC Characteristics for Panel Driving.....	6
5.2 DC Characteristics for Backlight Driving.....	7
5.3 Recommended Power ON/OFF Sequence.....	8
5.4 LED Driver.....	9
5.5 LCD Module Block Diagram.....	10
6. INTERFACE TIMING CHARACTERISTICS.....	11
6.1 Timing Characteristics.....	11
6.2 Input Signal Timing Chart	12
6.3 Input Data Mapping.....	13
7. OPTICAL CHARACTERISTICS	14
8. RELIABILITY TEST.....	17
9. MECHANICAL DRAWING	18
10. PACKING INSTRUCTION.....	19
11. PRECAUTIONS FOR USE OF LCD MODULES.....	20
11.1 Handling Precautions.....	20
11.2 Storage precautions.....	20
11.3 Transportation Precautions	20
11.4 Screen saver Precautions.....	20
11.5 Safety Precautions	20

1. Summary

1.1 General Description

This is a 15.6 inch a-Si TFT-LCD module with Normal- Black technology. It is composed of a TFT-LCD panel, a driver circuit, PCB, and a LED backlight unit.

1.2 Features

- Ultra-wide viewing angle
- High resolution
- Interface: LVDS
- Compliant with UL (UL62368-1/CSA C22.2 No.62368-1-03) .
- Acquisition product for the European RoHS directive (2011/65/EU) and Delegated Directive (2015/863/EU, Amending Annex II of 2011/65/EU).

2. General Specifications

	Feature	Spec	Unit
Display Spec	Size	15.6 inch	
	Resolution	1920(RGB) x 1080	
	Pixel Pitch	0.17925 x 0.17925	mm
	TFT Active Area	344.16 x 193.59	mm
	Technology Type	a-Si	
	Pixel Configuration	R.G.B Vertical Stripe	
	Display Mode	SFT, Normally Black	
	Surface Treatment	Anti-Glare	
	Viewing Direction	All Direction	
Mechanical Characteristics	LCM (W x H x D)	363.8 x 215.9 x 6.3 Typ.	mm
	Weight	618 Typ.	g
Optical Characteristics	Luminance	400 Typ.	cd/m ²
	Contrast Ratio	1000:1 Typ.	
	NTSC	72 Typ.	%
	Viewing Angle	88/88/88/88 Typ.	degree
Electrical Characteristics	Interface	LVDS (2 port), 8bit	
	Color Depth	16.7 Million	color
	Power Consumption	13.914 Typ.	W

Table 2.1 General TFT Specifications

3. Input / Output Terminals

3.1 CN1 Pin assignment (LCD Interface)

Connector Information	
LCD Module connector	187034-30091 (P-TWO INDUSTRIES)
Matching connector	FI-X30HL (JAE)

Table 3.1.1 Connector information

Pin No.	Symbol	Signal	Remarks
1	DA0-	Odd pixel data 0	Note1
2	DA0+		
3	DA1-	Odd pixel data 1	Note1
4	DA1+		
5	DA2-	Odd pixel data 2	Note1
6	DA2+		
7	GND	Ground	Note2
8	CLKA-	Odd pixel clock	Note1
9	CLKA+		
10	DA3-	Odd pixel data 3	Note1
11	DA3+		
12	DB0-	Even pixel data 0	Note1
13	DB0+		
14	GND	Ground	Note2
15	DB1-	Even pixel data 1	Note1
16	DB1+		
17	GND	Ground	Note2
18	DB2-	Even pixel data 2	Note1
19	DB2+		
20	CLKB-	Even pixel clock	Note1
21	CLKB+		
22	DB3-	Even pixel data 3	Note1
23	DB3+		
24	GND	Ground	Note2
25	GND	Ground	Note2
26	GND	Ground	Note2
27	GND	Ground	Note2
28	VCC	Power supply	Note2
29			
30			

Table 3.1.2 Pin Assignment for LCD Interface

Note1: Twist pair wires with 100Ω(Characteristic impedance) should be used between LCD panel signal processing board and LVDS transmitter.

Note2: All GND and VCC terminals should be used without any non-connected lines.

3.2 CN2 Pin assignment (Back Light)

Connector Information	
LCD Module connector	DF19L-14P-1H(54) (HIROSE ELECTRIC Co., Ltd.)
Matching connector	DF19-14S-1C (HIROSE ELECTRIC Co., Ltd.)

Table 3.2.1 Connector information

Pin No.	Symbol	Function	Description
1	VDD	Power supply	Note1
2	VDD		
3	VDD		
4	VDD		
5	VDD		
6	GND	LED driver board ground	Note1
7	GND		
8	GND		
9	GND		
10	GND		
11	Reserve	Keep open	-
12	BRTC	Backlight ON/OFF control	High or Open: Backlight ON Low: Backlight OFF
13	PWM	Luminance control	PWM Dimming
14	GND	LED driver board ground	Note1

Table 3.2.2 Pin Assignment for Back Light Interface

Note1: All VDDDB and GNDB terminals should be used without any non-connected lines.

3.3 Positions of Socket

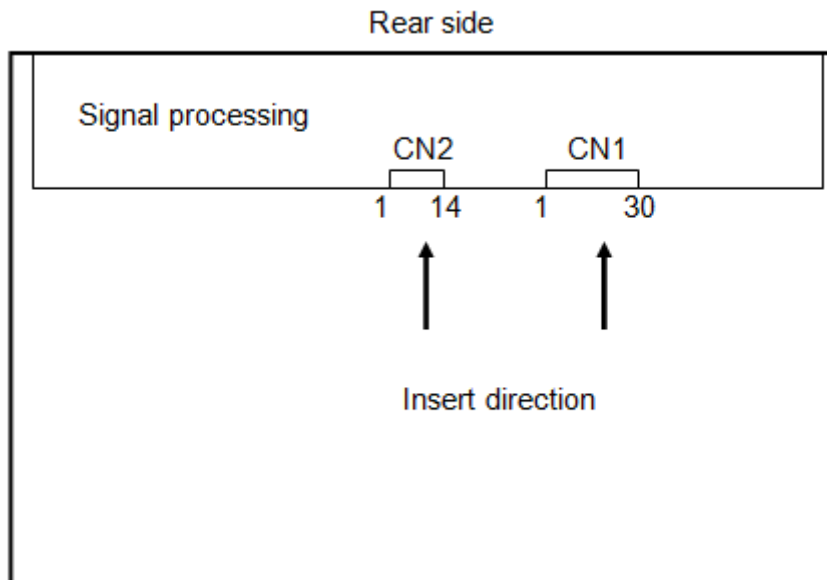

4. Absolute Maximum Ratings

GND=0V

Parameter		Symbol	Rating	Unit	Remarks
Power supply voltage	LCD panel signal processing board	VCC	-0.3to +4.0	V	Ta= 25°C
	LED driver	VDD	-0.3to +15.0		
Input voltage for signals	Display signals Note1	VD	-0.3to VCC+0.3	V	
	Function signal for LED driver	PWM	-0.3to +5.5	V	
		BRTC	-0.3to +5.5	V	
Storage temperature		Tst	-20 to +70	°C	
Operating temperature	Front surface	TopF	-20 to +70	°C	Note2
	Rear surface	TopR	-20 to +70	°C	Note3
Relative humidity Note4		RH	≤ 95	%	Ta ≤ 40°C
			≤ 85	%	40°C < Ta ≤ 50°C
			≤ 55	%	50°C < Ta ≤ 60°C
			≤ 36	%	60°C < Ta ≤ 70°C
Absolute humidity Note4		AH	≤ 70 Note5	g/m ³	Ta = 70°C

Table 4.1 Absolute Maximum Ratings

Note1: DA0+/-, DA1+/-, DA2+/-, DA3+/- ,CLKA+/-, DB0+/-, DB1+/-, DB2+/-, DB3+/-, CLKB+/-

Note2: Measured at LCD panel surface (including self-heat)

Note3: Measured at LCD module's rear shield surface (including self-heat)

Note4: No condensation

Note5: Water amount at Ta= 70°C and RH= 36%

Note6: The absolute maximum rating values of this product are not allowed to be exceeded at any times. A module should be used with any of the absolute maximum ratings exceeded, the characteristics of the module may not be recovered, or in an extreme condition, the module may be permanently destroyed.

5. Electrical Characteristics

5.1 DC Characteristics for Panel Driving

(Ta= 25°C)

Parameter	Symbol	min.	typ.	max.	Unit	Remarks	
Power supply voltage	VCC	3.0	3.3	3.6	V	-	
Power supply current	ICC	-	580 Note1	1000 Note2	mA	at VCC= 3.3V	
Permissible ripple voltage	VRPC	-	-	100	mVp-p	for VCC Note3, Note4, Note5	
Differential input threshold voltage	High	VTH	-	-	+100	mV	at VCM= 1.2V Note6, Note7
	Low	VTL	-100	-	-	mV	
Input Differential Voltage	VID	100	400	600	mV	-	
Differential Input Common Mode Voltage	VCM	0.7	1.2	1.6	V	-	
Terminating resistance	RT	-	100	-	Ω	-	

Table 5.1.1 Operating Voltages

Note1: Checkered flag pattern [by IEC 61747-6]

Note2: Pattern for maximum current

Note3: This product works even if the ripple voltage levels are over the permissible values, but there might be noise on the display image.

Note4: The permissible ripple voltage includes spike noise.

Note5: The load variation influence does not include.

Note6: Common mode voltage for LVDS receiver

Note7: DC characteristics (LVDS receiver part)

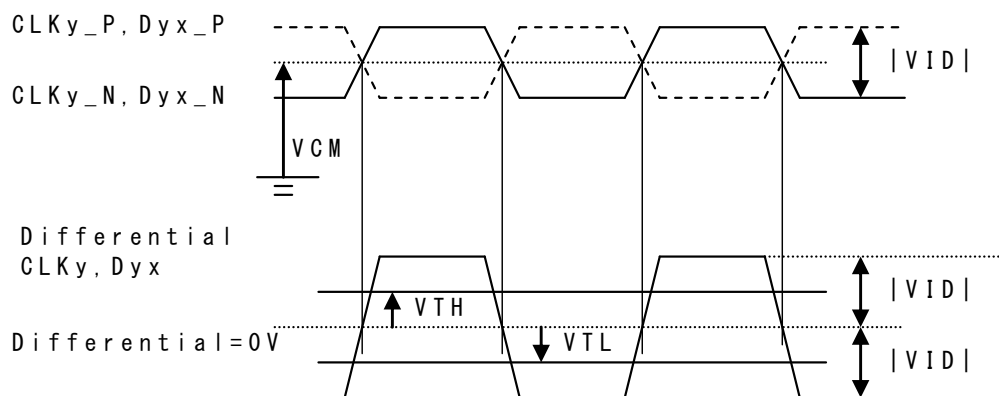

CLKy_P, CLKy_N: y = A,B
 Dyx_P, Dyx_N: y = A,B x = 0,1,2,3
 $|VID| = |**_P - **_N|$
 $VCM = (**_P + **_N) / 2$
 P: +, N: -
 **: CLKy or Dxy

5.2 DC Characteristics for Backlight Driving

(Ta= 25°C)

Parameter	Symbol	min.	typ.	max.	Unit	Remarks	
Power supply voltage	VDD	10.8	12.0	13.2	V	Note1	
Power supply current	IDD	-	1000	1250 Note2	mA	At the maximum luminance control	
Permissible ripple voltage	VRPD	-	-	200	mVp-p	for VDD Note3, Note4, Note5	
Input voltage for PWM signal	High	VDFH1	2.0	-	5.0	V	-
	Low	VDFL1	0	-	0.4		
Input voltage for BRTC signal	High	VDFH2	2.0	-	5.0		
	Low	VDFL2	0	-	0.4		
Input current for PWM signal	High	IBCH1	-	-	+200	μA	-
	Low	IBCL1	-200	-	-		
Input current for BRTC signal	High	IBCH2	-	-	+200		
	Low	IBCL2	-200	-	-		
PWM frequency	f _{PWM}	200	-	1k	Hz	Note6, Note8	
PWM duty ratio	DR _{PWM}	1	-	100	%	Note7, Note9, Note10	
PWM pulse width	tPWH	20	-	-	μs	Note9, Note10	
LED life time	Hr	-	50000	-	Hour	Note 11	

Table 5.2.1 LED Backlight Characteristics

Note1: When designing of the power supply, take the measures for prevention of surge voltage.

Note2: This value excludes peak current such as overshoot current.

Note3: This product works even if the ripple voltage levels are over the permissible values, but there might be noise on the display image.

Note4: The permissible ripple voltage includes spike noise.

Note5: The power supply lines (VDD and GND) may have ripple voltage during luminance control of LED. There is the possibility that the ripple voltage produces acoustic noise and signal wave noise in audio circuit and so on.

Note6: A recommended f_{PWM} value is as follows.

$$f_{PWM} = \frac{2n - 1}{4} \times fv$$

(n = integer, fv = frame frequency of LCD module)

Note7:

$$DR_{PWM} = \frac{tPWH}{tPW}$$

tPWH: PWM pulse width, tPW: PWM dimming cycle(= 1/f_{PWM})

Note8: Depending on the frequency used, some noise may appear on the screen, please conduct a thorough evaluation.

Note9: While the BRTC signal is high, do not set the tPWH (PWM pulse width) is less than minimum value. It may cause abnormal working of the backlight. In this case, turn the backlight off and then on again by BRTC signal.

Note10: Regardless of the PWM frequency, both PWM duty ratio and PWM pulse width must be always more than the minimum values.

Note11: Optical performance should be evaluated at Ta=25°C. Only If LED is driven by high current, high ambient temperature & humidity condition. The life time of LED will be reduced. Operating life means brightness goes down to 50% of initial brightness. Typical operating life time is an estimated data.

5.3 Recommended Power ON/OFF Sequence

Item	Symbol	Min	Typ	Max	Unit	Remark
VCC on to VCC stable	t1	0.5	-	50	ms	
VCC off to next VCC on	t2	50	-	-	ms	
VCC stable to Signal on	t3	0	-	-	ms	
VCC stable to Signal stable	t4	0	-	34	ms	
Signal off to VCC off	t5	0	-	35	ms	
Signal stable to BL on	t6	55	-	-	ms	

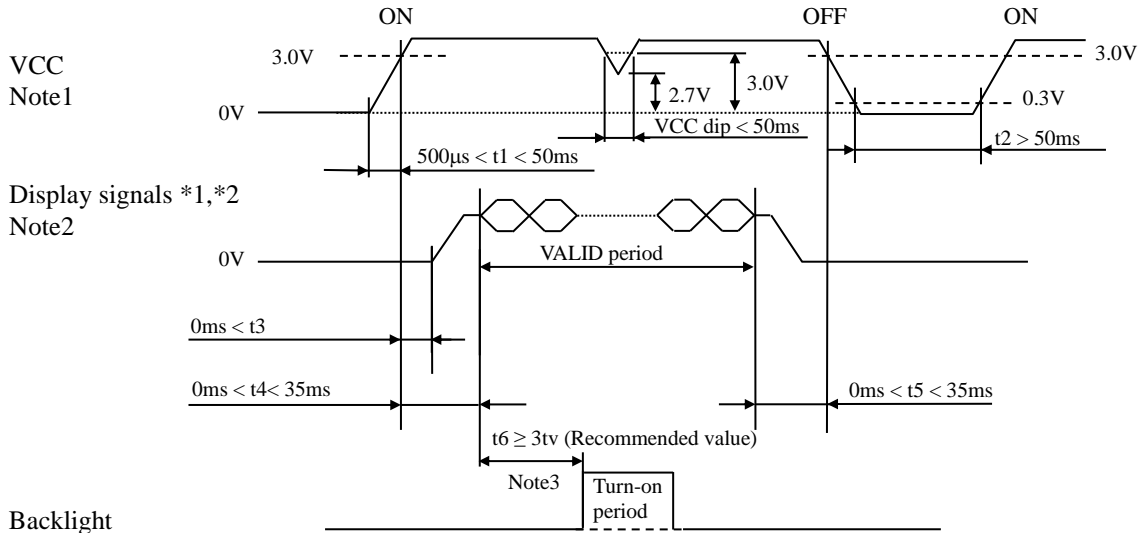

*1 DA0+/-, DA1+/-, DA2+/-, DA3+/-, CLKA+/-, DB0+/-, DB1+/-, DB2+/-, DB3+/-, CLKB+/-

*2 These signals should be measured at the terminal of 100Ω resistance.

Note1: If there is a voltage variation (voltage drop) at the rising edge of VCC below 3.0V, there is a possibility that a product does not work due to a protection circuit.

Note2: Display signals (DA0+/-, DA1+/-, DA2+/-, DA3+/-, CLKA+/-, DB0+/-, DB1+/-, DB2+/-, DB3+/-, CLKB+/-) must be set to Low or High-impedance, except the VALID period (See above sequence diagram), in order to avoid the circuitry damage.

If some of display signals of this product are cut while this product is working, even if the signal input to it once again, it might not work normally. If a customer stops the display signals, VCC also must be shut down.

Note3: In order to avoid unstable data display, the backlight is recommended to turn on within the VALID period of display and function signals.

Recommended value: t6 ≥ 3tv

(tv is vertical cycle (Please refer to 5.1 Timing characteristics))

5.4 LED Driver

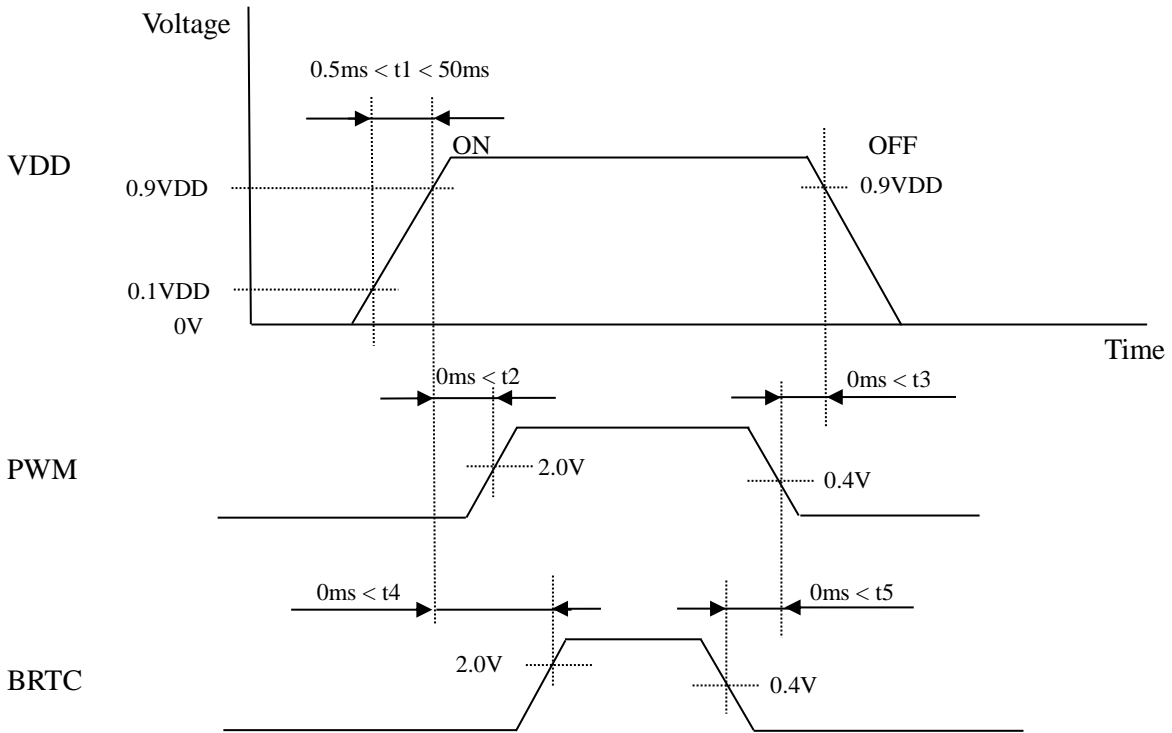

5.5 LCD Module Block Diagram

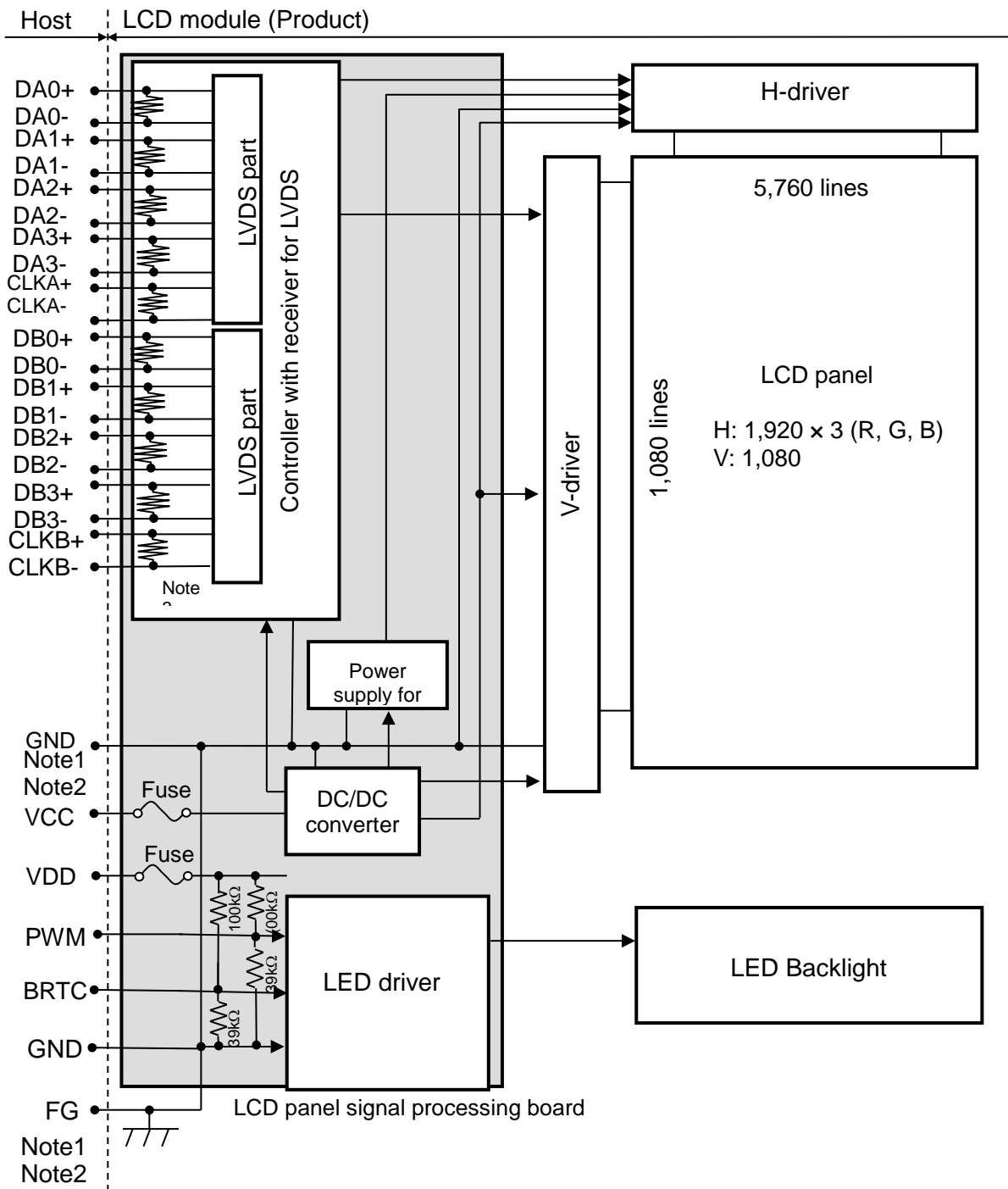

Figure 5.5.1 LCD Module Block Diagram

Note1: Relation between GND (Signal ground and LED driver ground) and FG (Frame ground) in the LCD module is as follows.

GND- FG	Connected
---------	-----------

Note2: GND and FG must be connected to customer equipment's ground, and it is recommended that these grounds to be connected together in customer equipment.

Note3: Each pair of the LVDS signal has a 100Ω terminating resistance.

6. Interface Timing Characteristics

6.1 Timing Characteristics

(Note1, Note2, Note3)

Parameter		Symbol	min.	typ.	max.	Unit	Remarks
CLK	Frequency	1/tc	68.64	70.94	71.74	MHz	14.10ns (typ.)
	Duty ratio	-	-			-	-
	Rise time, Fall time	-				ns	
DATA	CLK-DATA	Setup time	-			ns	-
		Hold time				ns	
	Rise time, Fall time	-				ns	
DE	Horizontal	Cycle	13.19	14.83	16.53	μs	67.43kHz (typ.)
			1040	1050	1060	CLK	
		Display period	960			CLK	-
	Vertical (One frame)	Cycle	-	16.7	-	ms	60Hz (typ.)
				1100	1126	1128	
		Display period	1,080			H	-
	CLK-DE	Setup time	-	-			ns
Hold time		-	ns				
	Rise time, Fall time	-	ns				

Table 6.1.1 Input Setup Timing Parameters Requirement

Note1: Definition of parameters is as follows.

$$t_c = 1\text{CLK}, t_h = 1\text{H}$$

Note2: See the data sheet of LVDS transmitter.

Note3: Vertical cycle (tv) should be specified in integral multiple of Horizontal cycle (th).

6.2 Input Signal Timing Chart

Horizontal timing

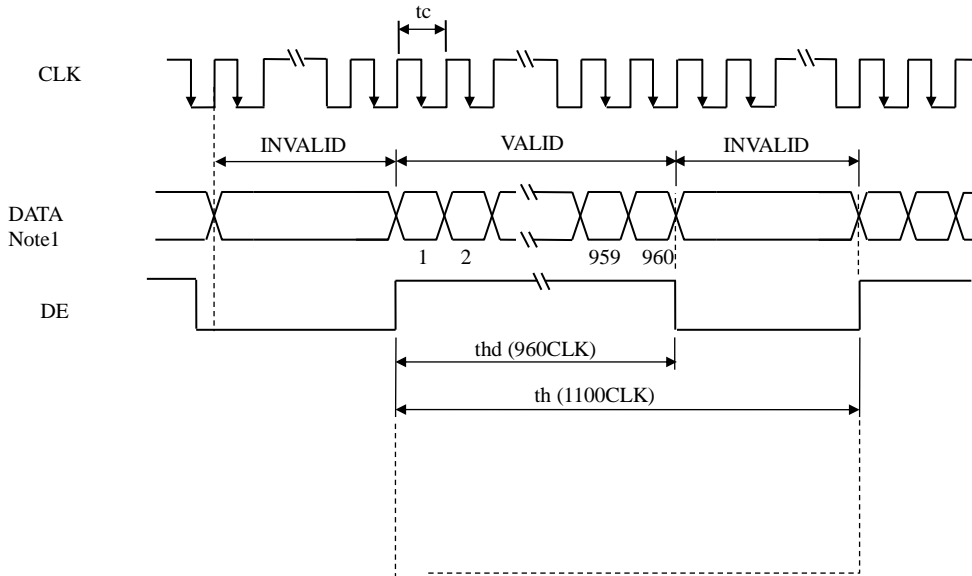

Vertical timing

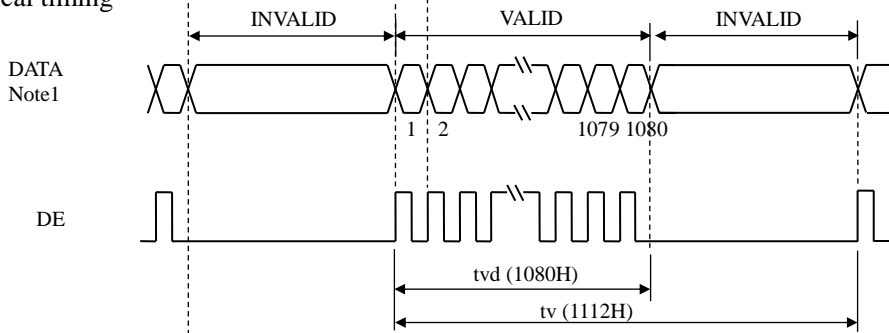

Note1: DATA = R0-R7, G0-G7, B0-B7

6.3 Input Data Mapping

(1) Input data signal:

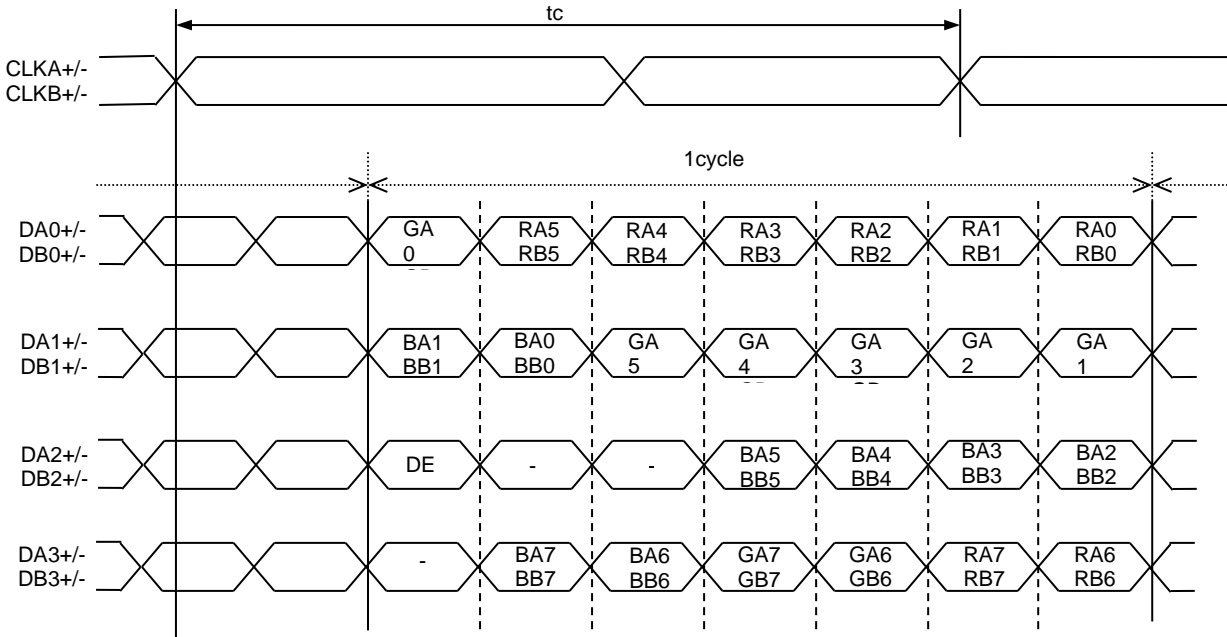

7. Optical Characteristics

Ta=25°C

Item	Symbol	Condition	Min	Typ	Max	Unit	Remark	
View Angles	θT	CR ≥ 10	70	88	-	Degree	Note 2	
	θB		70	88	-			
	θL		70	88	-			
	θR		70	88	-			
Contrast Ratio	CR	θ=0°	600	1000	-	-	Note1 Note3	
Response Time	T _{ON} +T _{OFF}	25°C	-	25	40	ms	Note1 Note4	
Chromaticity	White	Backlight is on	x	0.247	0.297	0.347	-	Note5 Note1
			y	0.276	0.326	0.376		
	Red		x	0.580	0.630	0.680		
			y	0.277	0.327	0.377		
	Green		x	0.227	0.277	0.327		
			y	0.574	0.624	0.674		
	Blue		x	0.101	0.151	0.201		
			y	0.011	0.061	0.111		
Uniformity	U	-	72	80	-	%	Note1 Note6	
NTSC	-	-	65	72	-	%	Note 5	
Luminance	L		280	400	-	cd/m ²	Note1 Note7	

Table 7.1 Optical Parameters

Test Conditions:

1. The ambient temperature is 25±2°C. humidity is 65±7%. PWM duty ratio is 100%.
2. The test systems refer to Note1 and Note2.

Note1: Definition of optical measurement system.

The optical characteristics should be measured in dark room. After 20 minutes operation, the optical properties are measured at the center point of the LCD screen. All input terminals LCD panel must be ground when measuring the center area of the panel.

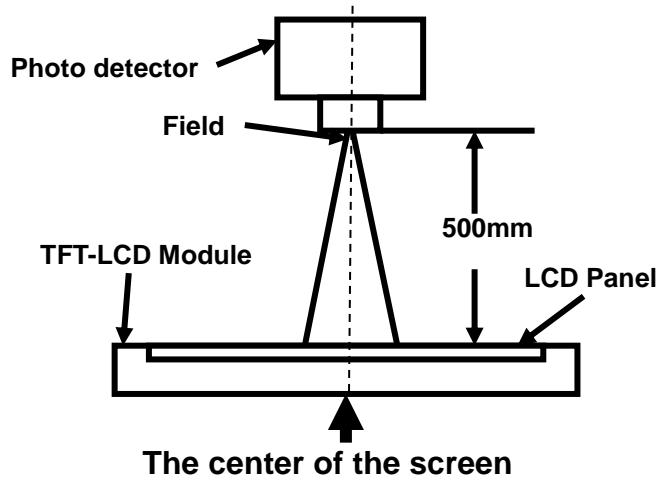

Fig1.Measurement Set Up

Note2: Definition of viewing angle range and measurement system.

Viewing angle is measured at the center point of the LCD .

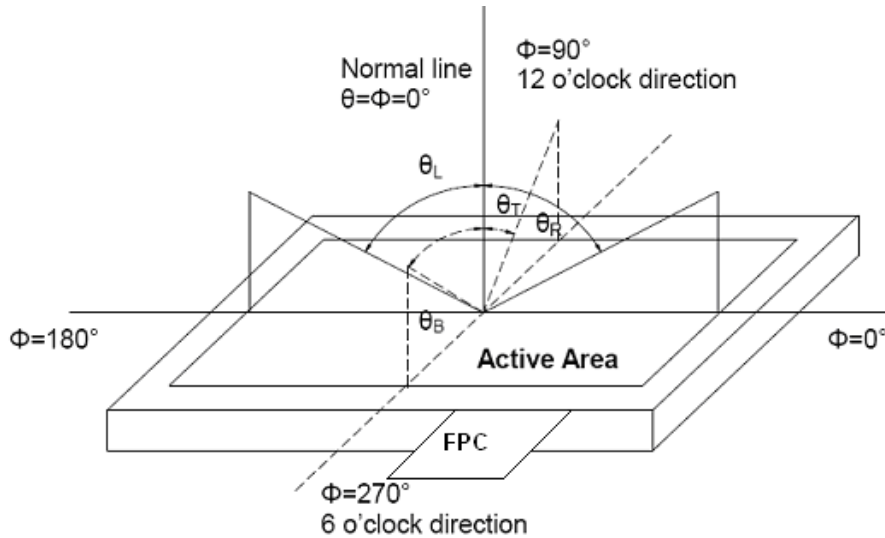

Fig2. Measurement viewing angle

Note3: Definition of contrast ratio

$$\text{Contrast ratio (CR)} = \frac{\text{Luminance measured when LCD is on the "White" state}}{\text{Luminance measured when LCD is on the "Black" state}}$$

Note4: Definition of Response time

The response time is defined as the LCD optical switching time interval between “Black” state and “White” state. Fall time (Ton) is the time between photo detector output intensity changed from 10% to 90%. And rise time (Toff) is the time between photo detector output intensity changed from 90% to 10%.

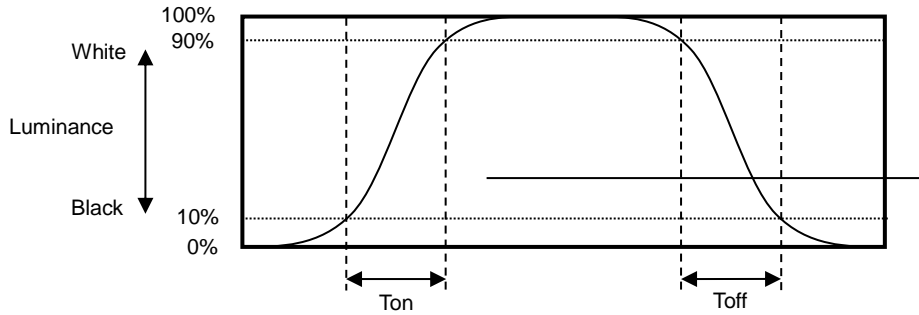

Fig3.Response Time Testing

Note5: Definition of color chromaticity (CIE1931)

Color coordinates measured at center point of LCD.

Note6: Definition of Luminance Uniformity

The luminance uniformity is calculated by using following formula.

$$\text{Luminance uniformity (LU)} = \frac{\text{Minimum luminance from ① to ⑤}}{\text{Maximum luminance from ① to ⑤}}$$

The luminance is measured at near the 5 points shown below.

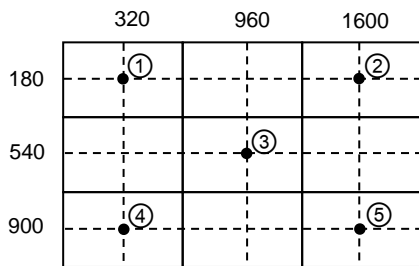

Fig4. Definition of uniformity

Note7: Definition of Luminance:

Measure the luminance of white state at center point.

8. Reliability Test

No	Test Item	Condition	Remarks
1	High Temperature Operation	①Ts = +70±3°C, 240 hours (Note1) ②Display data is white.	
2	Low Temperature Operation	Ts = -20±3°C, 240 hours (Note1)	
3	High Temperature & High Humidity Operation	①Ta = +60°C, 60% RH max, 240hours ②Display data is white.	
4	Thermal Shock (non-operation)	① -20 ± 3°C...30minutes +60 ± 3°C...30minutes ② 100cycles, 1hour/cycle ③ Temperature transition time is within 5 minutes.	No display malfunctions
5	ESD(Operation)	① 150pF, R=150Ω,10kV ② 9 places on a panel surface Note2 ③ 10 times each point at 1 sec interval	
6	Vibration (Non-operation)	① 5 to 100Hz, 11.76m/s ² ② 1 minute/cycle ③ X, Y, Z directions ④ 50 times each direction	No display malfunctions No physical damages
7	Shock (Non-operation)	① 294m/ s ² , 11ms ② ±X, ±Y, ±Z directions ③ 3 times each direction	

Table 8.1 RA test condition

Note1: Ts is the temperature of panel's surface.

Note2: Ta is the ambient temperature of sample.

Note3: Before cosmetic and function test, the product must have enough recovery time, at least 2 hours at room temperature.

Note 4: In the standard condition, there shall be no practical problem that may affect the display function. After the reliability test, the product only guarantees operation, but don't guarantee all of the cosmetic specification.

9. Mechanical Drawing

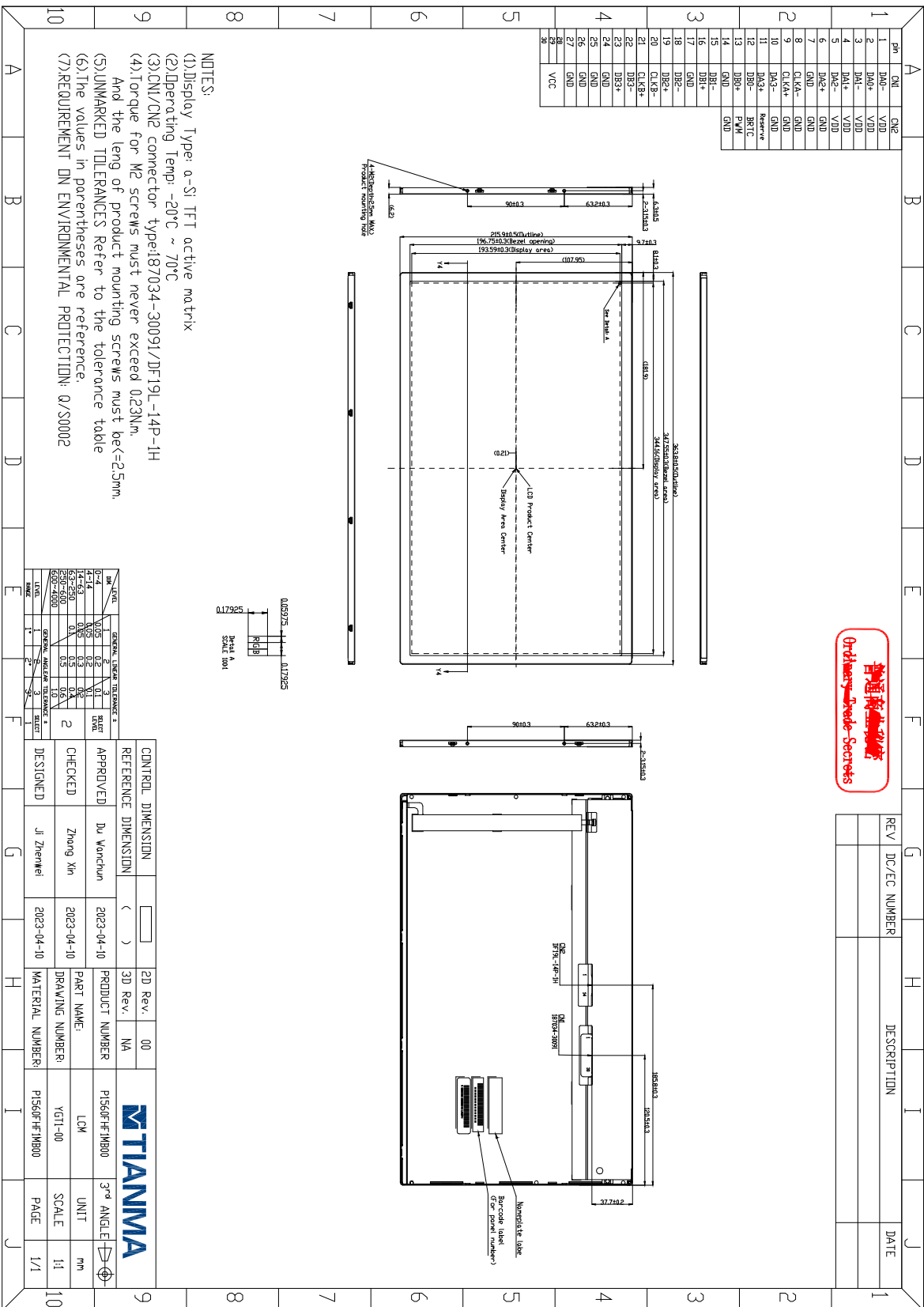

普通商標
Ordinary Trade Marks

10. Packing Instruction

No	Item	Model (Material)	Dimensions(mm)	Unit Weight(Kg)	Q'ty	Remark
1	LCM module	P1560FHF1MB00	363.8 x 215.9 x 6.3	0.618	10	
2	Partition board	Corrugated paper	384 x 229 x 5	0.05	2	
3	Anti-static Bag	LD-PE	435 x 325 x 0.05	0.005	10	
4	EPP1	EPP	496 x 80 x 40	0.025	1	
5	EPP2	EPP	496 x 375 x 125	0.22	2	
6	Carton	Corrugated paper	515 x 388 x 520	1.15	1	
7	Barcode Label	Paper	104x76	0.001	1	
8	Total weight	7.946 Kg±5 %				

11. Precautions for Use of LCD Modules

11.1 Handling Precautions

- (1) The display panel is made of glass. Do not subject it to mechanical shock by dropping it, etc.
- (2) If the display panel is damaged and the liquid crystal fluid inside it leaks out be sure not to get any in your mouth. If the fluid comes into contact with your skin or clothes promptly wash it off using soap and water.
- (3) Do not apply excessive force to the display surface or the bezel since this may cause the color tone to vary.
- (4) The polarizer covering the display surface of the LCD module is soft and easily scratched. Handle the polarizer carefully.
- (5) If the display surface is contaminated, breathe on the surface and gently wipe it with a soft dry cloth. If it is still not completely clear use a moist cloth with one of the following solvents:

- Isopropyl alcohol
- Ethyl alcohol

Solvents other than those mentioned above may damage the polarizer. Specifically, do not use the following:

- Water
- Ketone
- Aromatic solvents

- (6) Do not disassemble the LCD Module.
- (7) If powered off, do not apply the input signals.
- (8) To prevent destruction of the module by static electricity, be careful to maintain an optimum work environment.
- (9) Be sure to ground your body when handling the LCD Modules.
- (10) Tools used for assembly, must be properly grounded.
- (11) To reduce the amount of static electricity generated, do not conduct assembly or other work under very low humidity conditions.
- (12) The LCD Module is covered with a film to protect the display surface, remove film slowly under the ionizer.

11.2 Storage precautions

- (1) When storing the LCD modules avoid exposure to direct sunlight or to the light of fluorescent lamps.
- (2) The LCD modules should be stored within the rated storage temperature range. The recommend condition is: Temperature: 0 ~ 35 °C at normal humidity.
- (3) The LCD modules should be stored in a room without acid, alkali or other harmful gas.

11.3 Transportation Precautions

The LCD modules should not be dropped or subject to violent mechanical shock during transportation. Also they should avoid excessive pressure, water, high humidity and direct sunlight.

11.4 Screen saver Precautions

Not display the fixed pattern for a long time. Use a screen saver, if the fixed pattern is displayed on the screen

11.5 Safety Precautions

- (1) When you waste damaged or unnecessary LCDs, it is recommended to crush LCDs into pieces and wash them off with solvents such as acetone and ethanol, which should later be burned
- (2) Be sure to turn off the power supply when inserting or disconnecting the LED backlight cable.
- (3) LED driver should be designed carefully to limit or stop its function when over current is detected on the LED.