

Oct.1.2021 Copyright 2021 HIROSE ELECTRIC CO., LTD. All Rights Reserved.
In case of consideration for using Automotive equipment / device which demand high reliability, kindly contact our sales window correspondents.

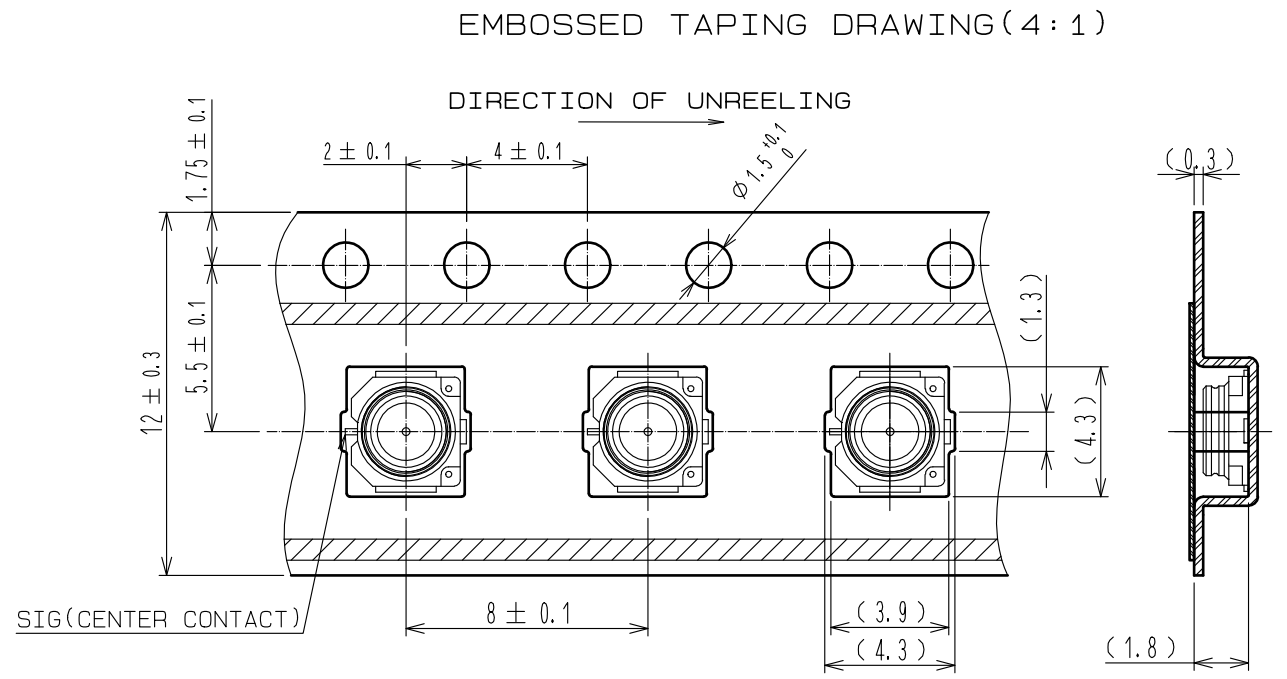

MOUNTING TEMPERATURE PROFILE (REFERENCE)

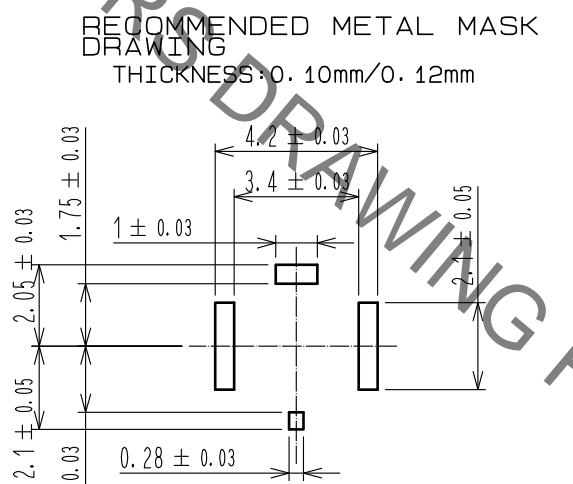
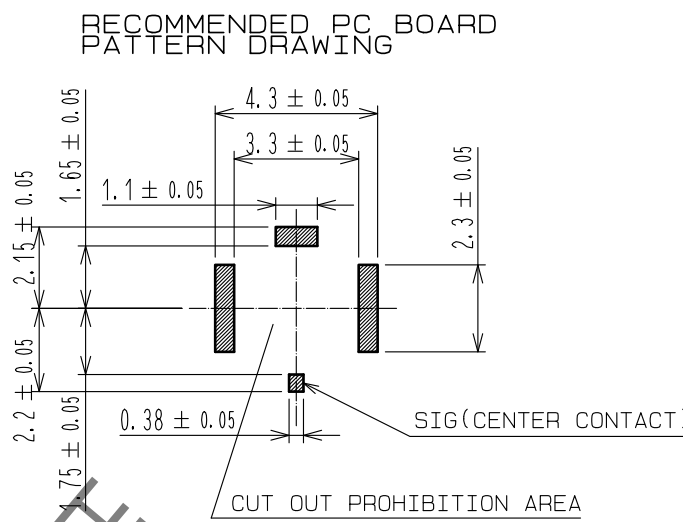
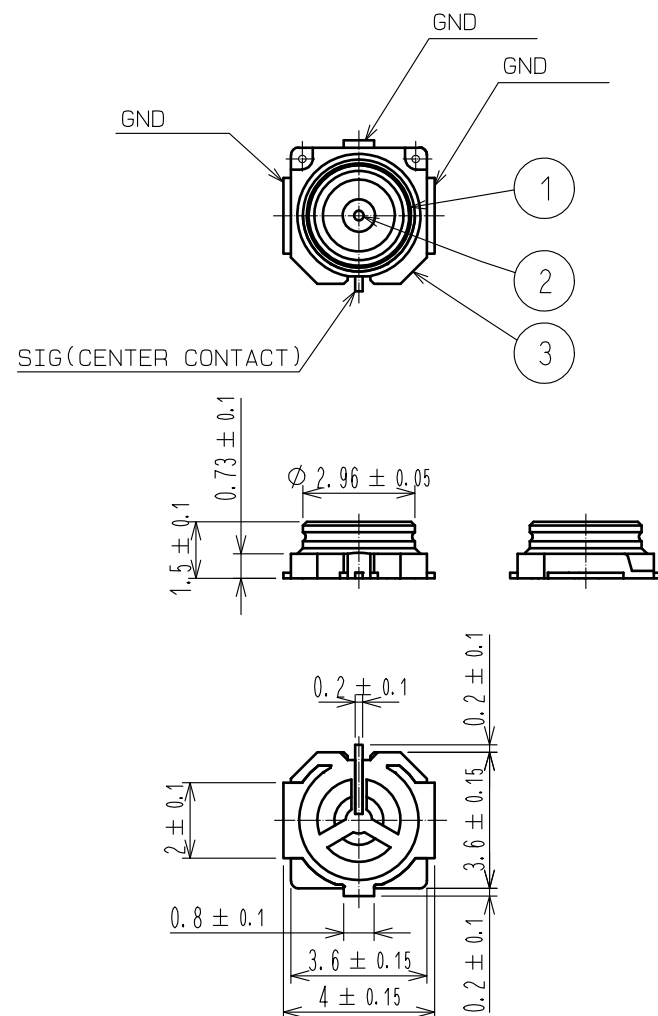
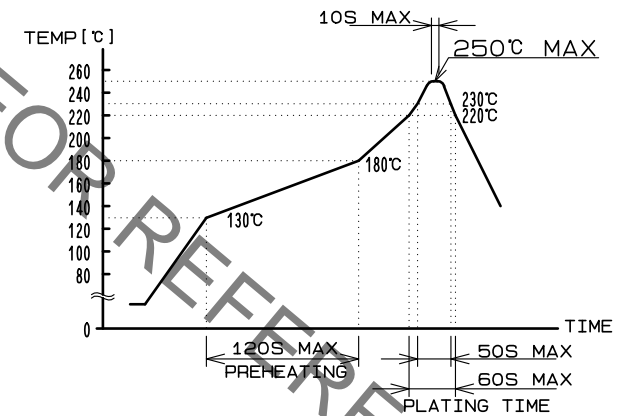

NOTE
MOUNTING TEMPERATURE PROFILE VARIES ACCORDING TO BOARD SIZE, SOLDER TYPE APPLIED AND SOLDER THICKNESS.
·METAL MASK THICKNESS: 0.10 mm / 0.12mm
·Up to 2 cycles of Reflow.

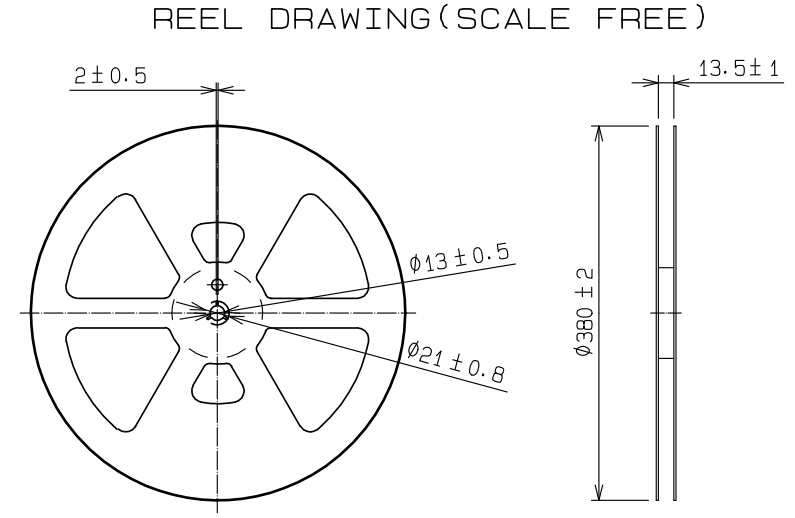

MATERIAL : PS (BLACK)

5000 PCS/PLASTIC REEL
HALOGEN FREE

NOTES:

- 1 : The quantity of D.FL75-R-SMT-1(40) is 5000 connectors per reel.
- 2 : Read co-planarity shall be 0.1max.
- 3 : For the possibility of breakage or deformation. Don't mate this connector with partner, D.FL75-LP(P)-*** before mounting on PC board.
- 4 : Use all products within 6 months after the delivery. Store them in manufacture's Package or tightly re-closed box with the following conditions.
Temperature: -10°C TO +40°C
Humidity : 15 TO 85% RH.
- 5 : Environmental conditions
Don't use the products under the environmental conditions as shown below due to possible product deterioration.
Special gas atmosphere (Hydrogen Sulfide gas, Sulfur Sulfide gas and Hydrogen Chloride gas)
Place attention required: heating system, area near hot spring, volcanic mountain and alike.
Water splashed and condensation places. Place attention required: harsh temperature change.

| 1 | PHOSPHOR BRONZE | GOLD PLATING | 3 | LCP | (BLACK) · UL94V-0 | |
|-------------------------|-----------------|--------------------------|-------|------------------------------|-------------------|------|
| 2 | PHOSPHOR BRONZE | GOLD PLATING | 2 | PHOSPHOR BRONZE | GOLD PLATING | |
| NO. | MATERIAL | FINISH . REMARKS | NO. | MATERIAL | FINISH . REMARKS | |
| UNITS | mm | SCALE | 5 : 1 | COUNT | △ | |
| | | DESCRIPTION OF REVISIONS | | DESIGNED | CHECKED | DATE |
| APPROVED : NK. NINOMIYA | | 20190215 | | DRAWING NO. EDC-375162-40-00 | | |
| CHECKED : NK. NINOMIYA | | 20190215 | | PART NO. D.FL75-R-SMT-1(40) | | |
| DESIGNED : MT. KANEKO | | 20190215 | | CODE NO. CL331-0079-0-40 | | |
| DRAWN : YK. KIUCHI | | 20190215 | | 1/1 | | |