

**Multi-Band GNSS Standard Precision
Positioning Module**

TAU1202 TAU1205

Datasheet V1.5

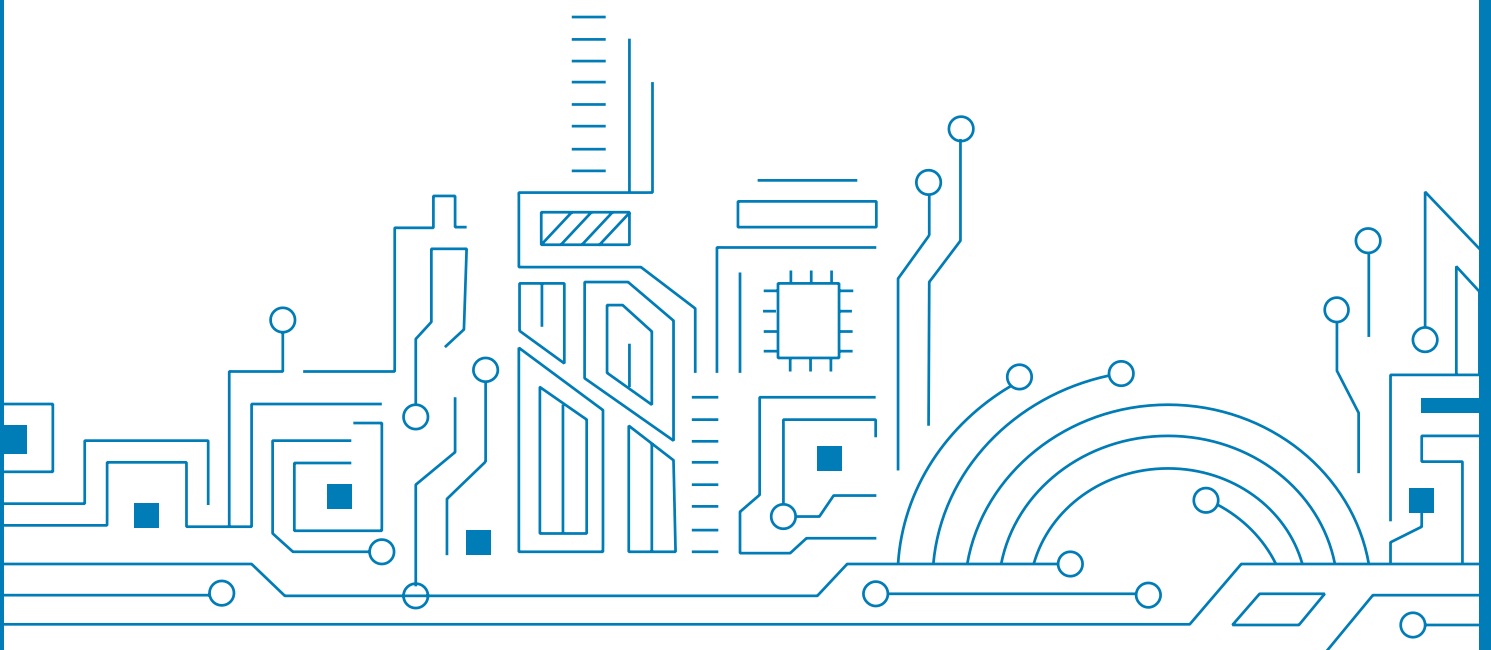

Notice, Statement and Copyright

ALLYSTAR Technology offers this document as a service to its customers, to support application and engineering efforts that use the products designed by ALLYSTAR Technology. Products and specifications discussed herein are for reference purposes only. Performance characteristics listed in this document do not constitute a warranty or guarantee of product performance.

ALLYSTAR Technology assumes no liability or responsibility for any claims or damages arising out of the use of this document, or from the use of integrated circuits based on this document, including, but not limited to claims or damages based on infringement of patents, copyrights or other intellectual property rights.

This document contains proprietary technical information which is the property of ALLYSTAR Technology, copying of this document and giving it to others and using or communication of the contents thereof, are forbidden without express authority. Offenders are liable to the payment of damages. ALLYSTAR Technology reserves the right to make changes in its products, specifications and other information at any time without notice.

For more documents, please visit www.allystar.com.

Copyright © ALLYSTAR Technology (Shenzhen) Co., Ltd. 2021. All rights reserved.

About the Document

■ Basic info

Document applies to	TAU1202, TAU1205
Document type	Datasheet
Revision and date	V1.5/2021-07
Product status	Mass production

■ Product status description

In development	Objective specification. Revision may be released in later status.
Engineering sample	Product specifications tested on early. Revision may be released in later status.
Preliminary	Product specifications come from small production. Revision may be released in later status.
Mass production	Final product specification to mass market.

TABLE OF CONTENT

1	SYSTEM OVERVIEW	6
1.1	Overview	6
1.2	Features	6
1.3	Module photo	7
1.4	Block diagram	7
1.5	Specifications	7
2	PIN DESCRIPTION	9
2.1	Pin assignment	9
2.2	Detailed pin descriptions	10
3	ELECTRICAL CHARACTERISTICS	11
3.1	Absolute Maximum Rating	11
3.2	IO Characteristics	11
3.2.1	PRRSTX and PRTRG	11
3.2.2	Others	11
3.3	DC Characteristics	12
3.3.1	Operating Conditions	12
3.3.2	Power Consumption	12
4	HARDWARE DESCRIPTION	13
4.1	Connecting power	13
4.2	Power on/off Sequence	13
4.2.1	Initial system power on	13
4.2.2	Main power supply off/on in application	13
4.3	Antenna design	14
4.4	Reset and mode control	15
4.5	Default Serial interfaces	15
5	MECHANICAL SPECIFICATION	16
6	REFERENCE DESIGN	17
6.1	Minimal Design	17
6.2	PCB Footprint Reference	17
6.3	Layout Notes	18
7	REFLOW SOLDERING	19
8	PRODUCT PACKAGING AND HANDLING	20
8.1	Packaging	20
8.1.1	Packaging Notes	20
8.1.2	Tape and Reel	20
8.1.3	Shipment Packaging	21
8.2	Storage	22
8.3	Handling	22
8.3.1	ESD Handling Precautions	22
8.3.2	ESD protection measures	22
8.3.3	Moisture sensitivity level	22
9	LABELING AND ORDERING INFORMATION	23
9.1	Labeling	23
9.2	Ordering info	23

10	RELATED DOCUMENTS	24
11	REVISION HISTORY	24

List of tables

Table 1 TAU1202/TAU1205	6
Table 2 Specifications	7
Table 3 Detailed pin descriptions	10
Table 4 Absolute rating	11
Table 5 PRRSTX and PRTRG	11
Table 6 Others	11
Table 7 Operating conditions	12
Table 8 Power consumption	12
Table 9 ANT_BIAS current range and antenna status	14
Table 10 Default messages	15
Table 11 Dimensions	16
Table 12 Reflow profile features	19
Table 13 Packing hierarchy	20
Table 14 Labeling content	23
Table 15 Ordering codes	23

List of figures

Figure 1 TAU1202/TAU1205 module photo	7
Figure 2 Block diagram	7
Figure 3 Pin assignment (top view)	9
Figure 4 Initial system power on sequence	13
Figure 5 Main power on sequence	14
Figure 6 Dimensions	16
Figure 7 Minimal application diagram	17
Figure 8 PCB Footprint Reference	17
Figure 9 Reflow soldering profile (Refer to IPC/JEDEC J-STD-020E)	19
Figure 10 Tape dimensions	20
Figure 11 Reel dimensions	21
Figure 12 Packaging	21

1 SYSTEM OVERVIEW

1.1 Overview

TAU1202/TAU1205 is a high-performance dual-frequency GNSS positioning module, which is based on the state of the art CYNOSURE III architecture. It supports GPS, BeiDou, GLONASS, Galileo, NAVIC/IRNSS, and QZSS).

TAU1202/TAU1205 integrates efficient power management architecture, while providing high precision, high sensitivity and low power GNSS solutions which make it suitable for navigation applications on automotive and consumer electronics, as well as fleet management.

1.2 Features

- Supports all civil GNSS systems
- Supports BDS-3 signal: B2a
- Concurrent reception of L1 and L5 band signals
- Sub-meter position accuracy, superior in multipath mitigation and lower noise in city valley
- Smart jammer detection and suppression
- Highly integrated module, the best cost-effective high precision solution
- Supports single IRNSS mode (TAU1205)

Table 1 TAU1202/TAU1205

Product	GNSS						Features					Interface			Accuracy		Grade				
	Band (S/D/T)	GPS	BDS	GLONASS	Galileo	IRNSS	Built-in LNA	Programmable (flash)	Data logging	D-GNSS	Oscillator	UART	I2C	USB	SPI	Meter	Sub-meter	Centimeter	Standard	Professional	Automotive
TAU1202-1010A00	D	●	●	●	●		●	●	●	●	T	●	○				●		●		
TAU1205-1010A00	D	●	●		●	●	●	●	●	●	T	●	○				●		●		

T= TCXO

○=Supported upon request with special FW

1.3 Module photo



Figure 1 TAU1202/TAU1205 module photo

1.4 Block diagram

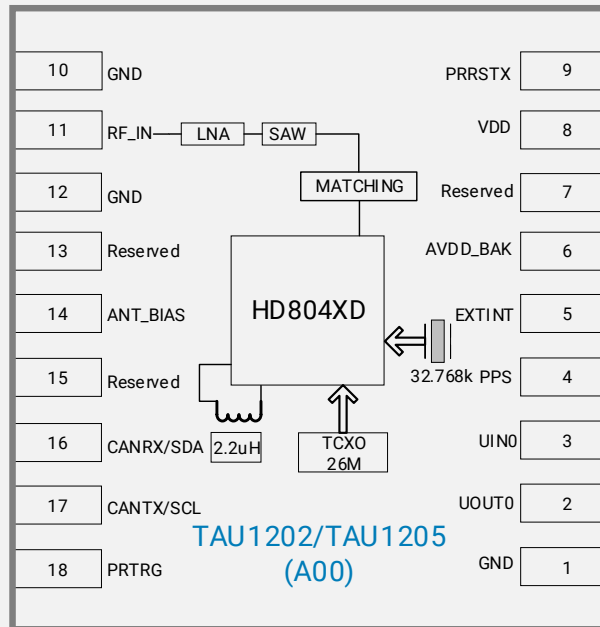

Figure 2 Block diagram

1.5 Specifications

Table 2 Specifications

Parameter	Specification	
GNSS Tracking channels	40	
GNSS reception	TAU1202	GPS/QZSS: L1C/A, L5C
		BDS: B1I, B2a
		GLONASS: L10F
		Galileo: E1, E5a
	TAU1205	GPS/QZSS: L1C/A, L5C
		BDS: B1I, B2a

		Galileo: E1, E5a
		IRNSS: L5
Update rate	Maximum 10Hz	
Position accuracy ^[1]	GNSS	<1m CEP
Velocity & Time accuracy	GNSS	0.1m/s CEP
	1PPS	20ns
Time to First Fix(TTFF)	Hot start	1 sec
	Cold start	24 secs
Sensitivity	Cold start	-148dBm
	Hot start	-155dBm
	Reacquisition	-158dBm
	Tracking & navigation	-161dBm
Operating limit	Velocity	515 m/s
	Altitude	18,000 m
Safety supervision	Antenna short circuit protection and open circuit detection	
Serial interface	UART	1
	I2C ^[2]	1
	CAN ^[2]	1
Protocol	NMEA 0183 Protocol Ver. 4.00/4.10 RTCM 3.0/3.2/2.3/2.4x ^[3] Cynosure GNSS Receiver Protocol	
Operating condition	Main voltage	2.0 ~ 3.6V
	Digital I/O voltage	1.8 ~ 3.6V
	Backup voltage	1.8 ~ 3.6V
Power consumption	GPS+QZSS, L1 band	22mA@3.3V
	GNSS, L1+L5 band	41mA@3.3V
	Standby	12uA
Operating temperature	-40 °C ~ +85 °C	
Storage temperature	-40 °C ~ +85 °C	
Package	10.1mm x 9.7mm x 2.5mm 18-pin stamp hole	
Certification	RoHS & REACH	

* [1] Open sky, dual band, demonstrated with a good external LNA

* [2] Supported upon request with special FW

* [3] RTCM 2.3/2.4x are supported upon request with special FW.

2 PIN DESCRIPTION

2.1 Pin assignment

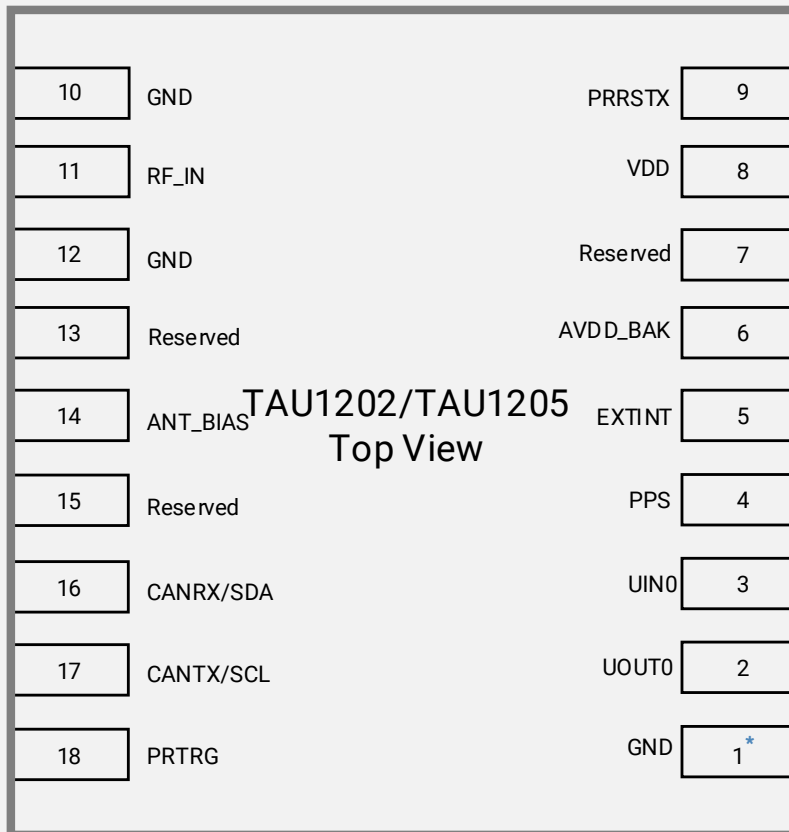

* Pin 1 aligns to the circular hole on module cover.

Figure 3 Pin assignment (top view)

2.2 Detailed pin descriptions

Table 3 Detailed pin descriptions

Function	Symbol	No.	I/O	Description
Power	VDD	8	Power	Main supply input.
	GND	1,10,12	VSS	Ground
	AVDD_BAK	6	Power	Backup supply input.
Antenna	RF_IN	11	I	RF signal input. Use a controlled impedance of 50Ω from connect RF_IN to the antenna or the antenna connector.
	ANT_BIAS	14	O	RF section output voltage. Used to power the external active antenna. The current is limited below 35mA.
UART	UOUT0	2	O	UART0 serial data output.
	UIN0	3	I	UART0 serial data input.
I ² C/CAN ^[1]	CANRX/SDA	16	I/O	I ² C data transmission, or CAN data input. Leave it floating if not used.
	CANTX/SCL	17	I/O	I ² C clock, or CAN data output. Leave it floating if not used.
System	PRTRG	18	I	Mode selection, or the trigger input in deep sleep mode to wake up the system
	PRRSTX	9	I	External reset, low active
	PPS	4	O	Time pulse output (PPS)
	EXTINT	5	I	GPIO, Default (EXTINT): a trigger pin to external interrupt, leave it floating if not used.
Reserved	Reserved	7,13,15	–	Reserved, leave it floating if not used

* [1] Supported upon request with special FW

3 ELECTRICAL CHARACTERISTICS

3.1 Absolute Maximum Rating

Table 4 Absolute rating

Symbol	Parameter	Min.	Max.	Unit
VDD	Power input for the main power domain	-0.5	3.63	V
AVDD_BAK	Power input for the backup power domain	-0.5	3.63	V
T _{storage}	Storage temperature	-40	85	°C
T _{solder}	Solder reflow temperature	--	260	°C

3.2 IO Characteristics

3.2.1 PRRSTX and PRTRG

Table 5 PRRSTX and PRTRG

Symbol	Parameter	Condition	Min.	Typ.	Max.	Unit
I _{Iz}	Input leakage current	--	--	--	+/-1	uA
V _{IH}	Input high voltage	--	AVDD_BAK*0.7	--	AVDD_BAK	V
V _{IL}	Input low voltage	--	0	--	AVDD_BAK*0.3	V
C _i	Input capacitance	--	--	--	10	pF
R _{PU}	Pull-up resistance	--	18	--	84	kOhm

3.2.2 Others

Table 6 Others

Symbol	Parameter	Condition	Min.	Typ.	Max.	Unit
I _{Iz}	Input leakage current	--	--	--	+/-1	uA
V _{IH}	Input high voltage	--	VDD*0.7	--	VDD	V
V _{IL}	Input low voltage	--	0	--	VDD*0.3	V
V _{OH}	Output high voltage	I _{OH} =11.9 mA, VDD=3.3V	2.64	--	--	V
V _{OL}	Output low voltage	I _{OL} =7.9 mA, VDD=3.3V	--	--	0.4	V
C _i	Input capacitance	--	--	--	11	pF
R _{PU}	Pull-up resistance	-	35	--	84	kOhm

3.3 DC Characteristics

3.3.1 Operating Conditions

Table 7 Operating conditions

Symbol	Parameter	Min.	Typ.	Max.	Unit
VDD	Power input for the main power domain	2.0	3.3	3.6	V
AVDD_BAK	Power input for the backup power domain	1.8	3.3	3.6	V
I _{ANT_BIAS}	ANT_BIAS output current	-	-	35	mA
V _{ANT_BIAS}	ANT_BIAS output voltage	-	VDD-0.2	-	V
ICC _{max}	Maximum operating current @ VDD	--	--	200	mA
T _{env}	Operating temperature	-40	--	85	°C

3.3.2 Power Consumption

Table 8 Power consumption

Symbol	Parameter	Measure Pin	Typ.	Unit
I _{CCR1}	Average tracking current (GPS+QZSS, L1 only)	VDD ^[1]	22	mA
I _{CCR2}	Average tracking current (GNSS, L1+L5)	VDD ^[1]	41	mA
I _{CCDBM}	Standby mode	AVDD_BAK ^[2]	12	uA

* [1] Condition: VDD=3.3V@Room Temperature; All Pins Open.

* [2] Condition: AVDD_BAK=3.3V@Room Temperature; All Pins Open.

4 HARDWARE DESCRIPTION

4.1 Connecting power

TAU1202/TAU1205 positioning module has two power supply pins: VDD and AVDD_BAK. The main power is supplied through the VDD pin, and the backup power is supplied through the AVDD_BAK pin. In order to ensure the positioning performance, please control the ripple of the module power supply less than 50m Vpp. It is recommended to use the LDO above 200mA current.

If the power for VDD pin is off, the real-time clock (RTC) and battery backed RAM (BBR) are supplied through the AVDD_BAK pin. Thus, orbit information and time can be maintained and will allow a Hot or Warm start. If no backup battery is connected, the module performs a cold start at every power up if no aiding data are sent to the module.

Note: If no backup supply is available, connect the AVDD_BAK pin to VDD or leave it floating.

4.2 Power on/off Sequence

TAU1202/TAU1205 has two independent power domains (backup and main domain). In data backup mode, main power supply can be completely shut down for further power reduction for ultra-low power application.

4.2.1 Initial system power on

When both backup and main supply power on from their off state, external reset (PRRSTX) must be active and hold more than 5ms after both backup supply and main supply reach the minimum operating voltage. Initial system power on sequence is illustrated in Figure 4.

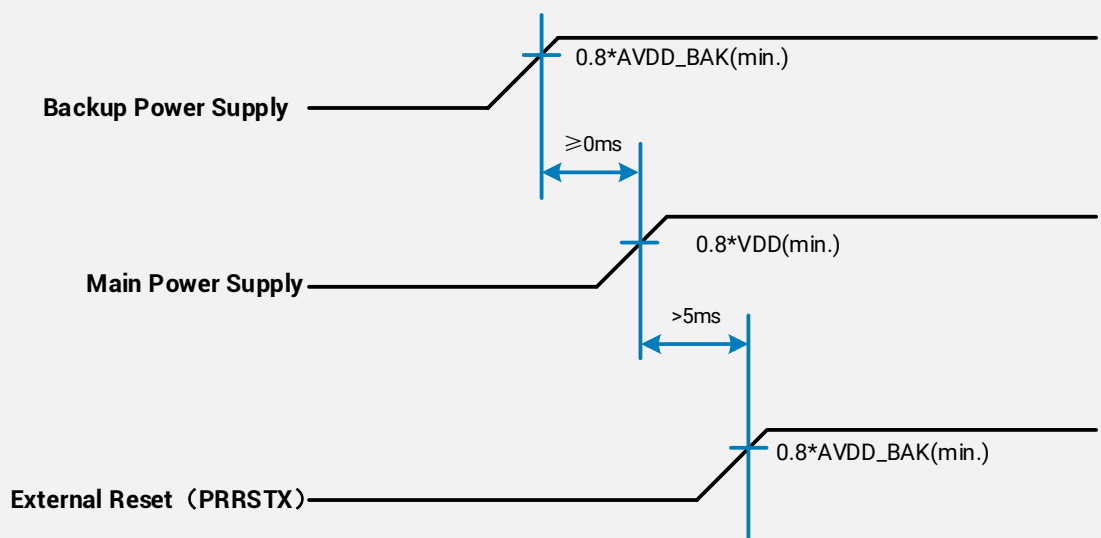

Figure 4 Initial system power on sequence

4.2.2 Main power supply off/on in application

If application intends to shut down main power supply (VDD) while keep backup power supply

(AVDD_BAK) alive to save backup data, the following rules should be applied:

External reset (PRRSTX) must be active when main power supply is under power off. In this case, external reset must be hold active more than 5ms after main power supply resumes to minimum operating voltage. Main power on sequence in application is illustrated in Figure 5.

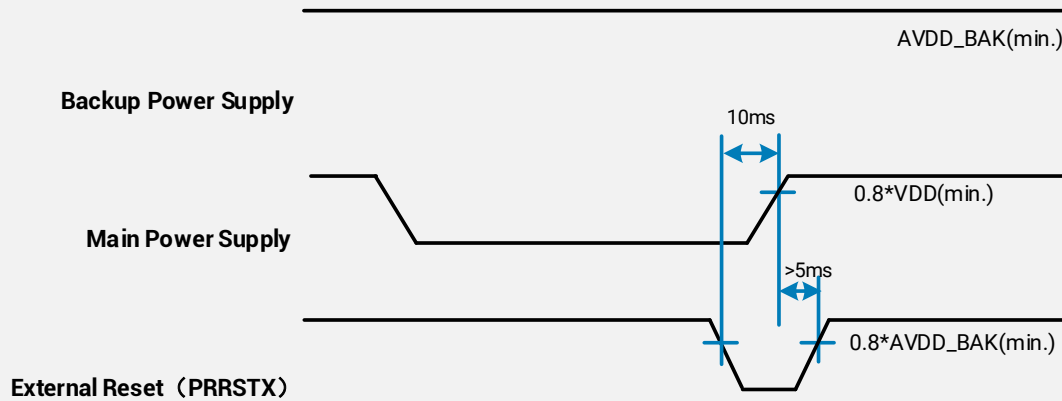

Figure 5 Main power on sequence

4.3 Antenna design

There is built-in LNA and SAW in the GNSS module. It is recommended to use an active antenna with gain less than 36dB and noise figure less than 1.5dB.

The module has built-in short circuit detection and open circuit detection function, which can detect the status of normal connection, and send out antenna status prompt message in NMEA data.

- **Short circuit protection**
 - » The module includes internal short circuit antenna detection. Once an overcurrent is detected at the ANT_BIAS port, the module will restrict current output automatically to protect from damages.
- **Open circuit detection**
 - » The module can detect an open circuit in the antenna. Users can judge it from antenna status messages.

Table 9 ANT_BIAS current range and antenna status

Antenna status	Status output	ANT_BIAS current range
Open circuit	OPEN	$0 < \text{ANT_BIAS} \leq 1\text{mA}$
Regular circuit or open circuit	OK or OPEN	$1\text{mA} < \text{ANT_BIAS} \leq 2\text{mA}$
Regular circuit	OK	$2\text{mA} < \text{ANT_BIAS} \leq 40 \pm 5\text{mA}^{[1]}$
Short circuit	SHORT	$40 \pm 5\text{mA}^{[1]} < \text{ANT_BIAS} < 55\text{mA}$

* [1] $\pm 5\text{mA}$ are differences between product batches.

TIPs:

1. Pulse width of the minimum detectable overshoot current should be more than 10uS.
2. NMEA message of antenna status output:

- OPEN: \$GNTXT,01,01,01,**ANT_OPEN***40
- OK: \$GNTXT,01,01,01,**ANT_OK***50
- SHORT: \$GNTXT,01,01,01,**ANT_SHORT***06

4.4 Reset and mode control

The operation mode of GNSS module is controlled by PRRSTX (nRESET) and PRTRG (BOOT) pin. While the module works in normal operation, leave PRRSTX and PRTRG pins floating if there is no upgrading or reset demands, or others.

- Keep PRTRG pin floating during system power-up or the external reset (PRRSTX from low to high), and the module will enter **User Normal Mode**.
- When the module powers up or PRRSTX from low to high, the module will execute an **external reset**. (If the power for AVDD_BAK is always on, the external reset will not affect the ephemeris data in the backup domain)
- Drive PRTRG pin to low or connect PRTRG to GND directly (not by pull-down resistance) during system power-up or the external reset (PRRSTX from low to high), and the system enters **BootROM Command Mode** at PRTRG pin being released from low to floating state, and ready for firmware upgrading command.
- When connecting PRRSTX and PRTRG to any host IO, DO NOT use the pull-up or pull-down resistance.

4.5 Default Serial interfaces

Table 10 Default messages

Interface	Settings
UART output	115200 baud, 8 data bits, no parity bit, 1 stop bit Configured to transmit both NMEA and HD Binary protocols, but only the following NMEA (and no HD Binary sentence) messages have been activated at start-up: GGA, GSA, GSV, RMC, ZDA, TXT-ANT
UART input	115200 baud, 8 data bits, no parity bit, 1 stop bit, autobauding disabled Automatically accepts following protocols without need of explicit configuration: HD binary sentence, NMEA, RTCM The GNSS receiver supports interleaved HD binary and NMEA messages.
Timepulse (1Hz Nav)	1 pulse per second, synchronized at rising edge, pulse length 100ms

* Refer to *GNSS_Protocol_Specification* for information about other settings.

When the module is applied to the specific application, users can shut off the main power in order to further reduce the power consumption. To avoid the high level in serial interface influencing the normal operation, it is highly suggested to cut off the serial port when shut off the main power. Otherwise, please set the serial port to input mode or high impedance state with pull-down resistor.

5 MECHANICAL SPECIFICATION

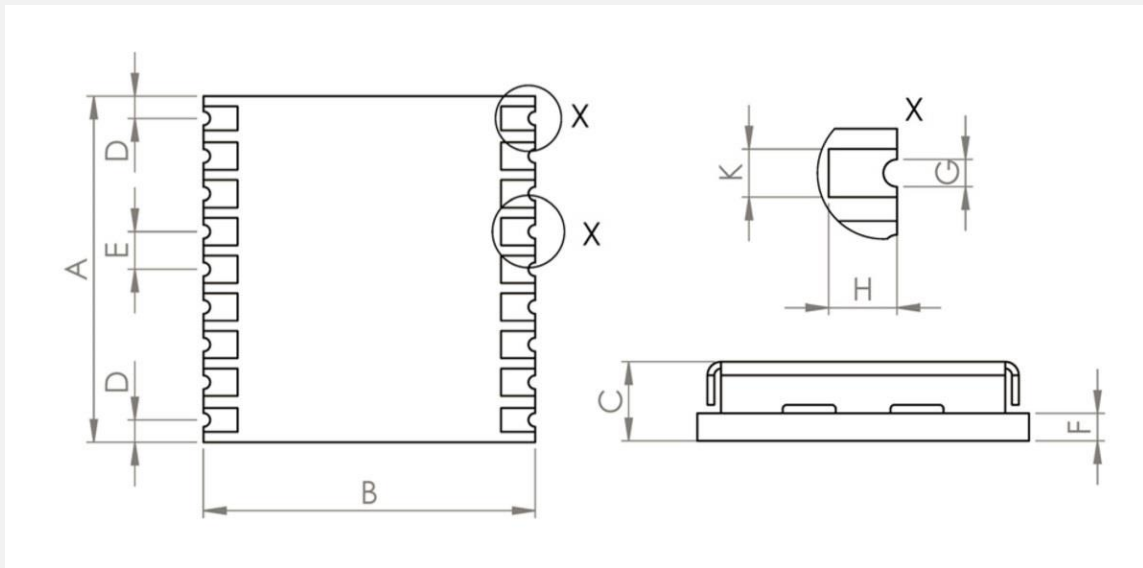

Figure 6 Dimensions

Table 11 Dimensions

Symbol	Min. (mm)	Typ.(mm)	Max. (mm)
A	9.9	10.1	10.3
B	9.5	9.7	9.9
C	2.3	2.5	2.7
D	0.55	0.65	0.95
E	1.0	1.1	1.2
F	0.6	0.8	--
G	0.4	0.5	0.6
H	0.8	0.9	1.0
K	0.7	0.8	0.9

6 REFERENCE DESIGN

6.1 Minimal Design

This is a minimal design for TAU1202/TAU1205 GNSS module as below. The 82nH inductor is used only when an active antenna is connected, and no need with a passive antenna. The characteristic impedance from RF_IN pin to the antenna connector should be 50Ω.

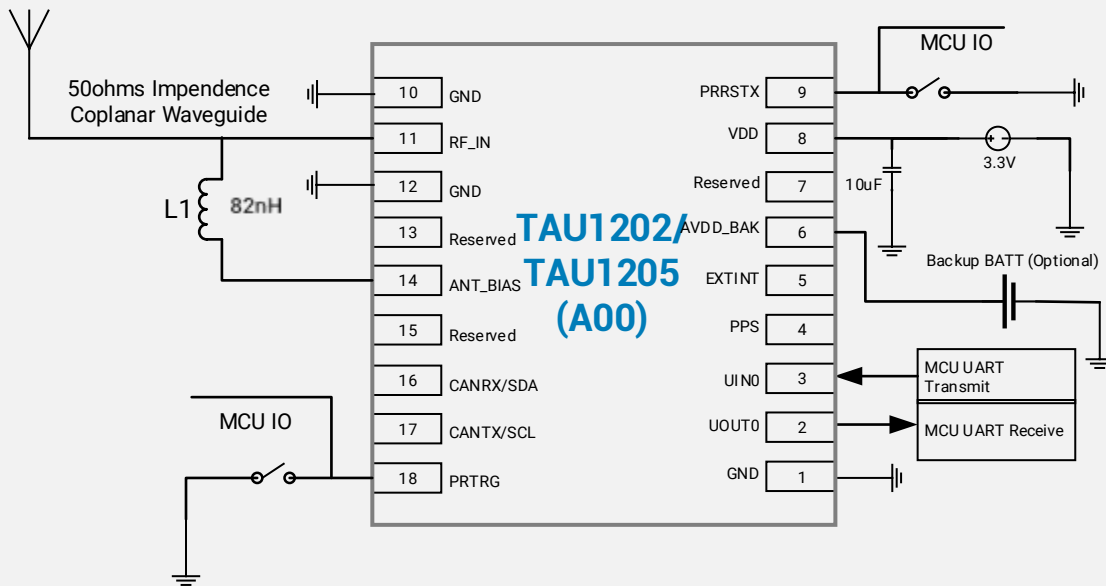

Figure 7 Minimal application diagram

6.2 PCB Footprint Reference

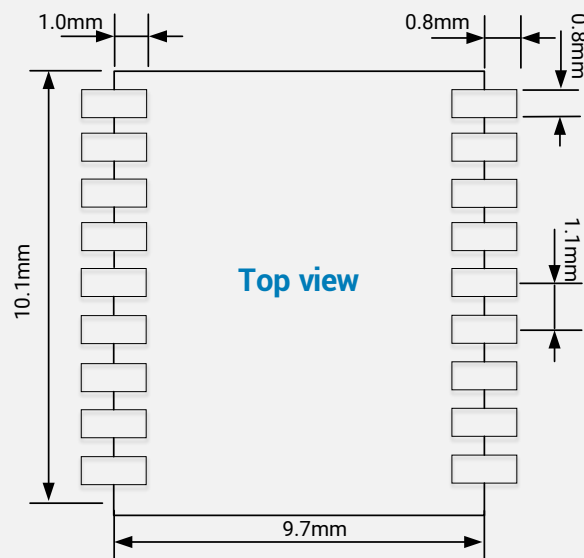

Figure 8 PCB Footprint Reference

6.3 Layout Notes

- (1) A decoupling capacitor should be placed close to VDD pin of the module, and the width of power routing should be more than 0.5mm.
- (2) The width of RF routing between RF port to antenna interface should be wider than 0.2mm. The characteristic impedance of RF routing between RF port to antenna interface should be controlled to 50Ω.
- (3) It is recommended that the routing from RF port to antenna interface refers to the second layer, and no routing are recommended on the layer.
- (4) Do not place the module close to any EMI source, like antenna, RF routing, DC/DC or power conductor, clock signal or other high-frequency switching signal, etc.

7 REFLOW SOLDERING

Table 12 Reflow profile features

Profile Feature	Pb-Free Assembly
Preheat/Soak	
Temperature Min (T_{smin})	150 °C
Temperature Max (T_{smax})	200 °C
Time (t_s) from (T_{smin} to T_{smax})	60-120s
Ramp-up rate (T_L to T_p)	3 °C/second max.
Liquidous temperature (T_L)	217 °C
Time (t_L) maintained above T_L	60-150s
Peak package body temperature (T_p)	must not exceed the Classification temp T_c ^[1]
Time (t_p)* within 5 °C of the specified classification temperature (T_c)	30* seconds ^[2]
Ramp-down rate (T_p to T_L)	6 °C/second max.
Time 25 °C to peak temperature	8 minutes max.

* [1] $T_c=260^{\circ}C$.

* [2] The time above 255 °C must not exceed 30 seconds.

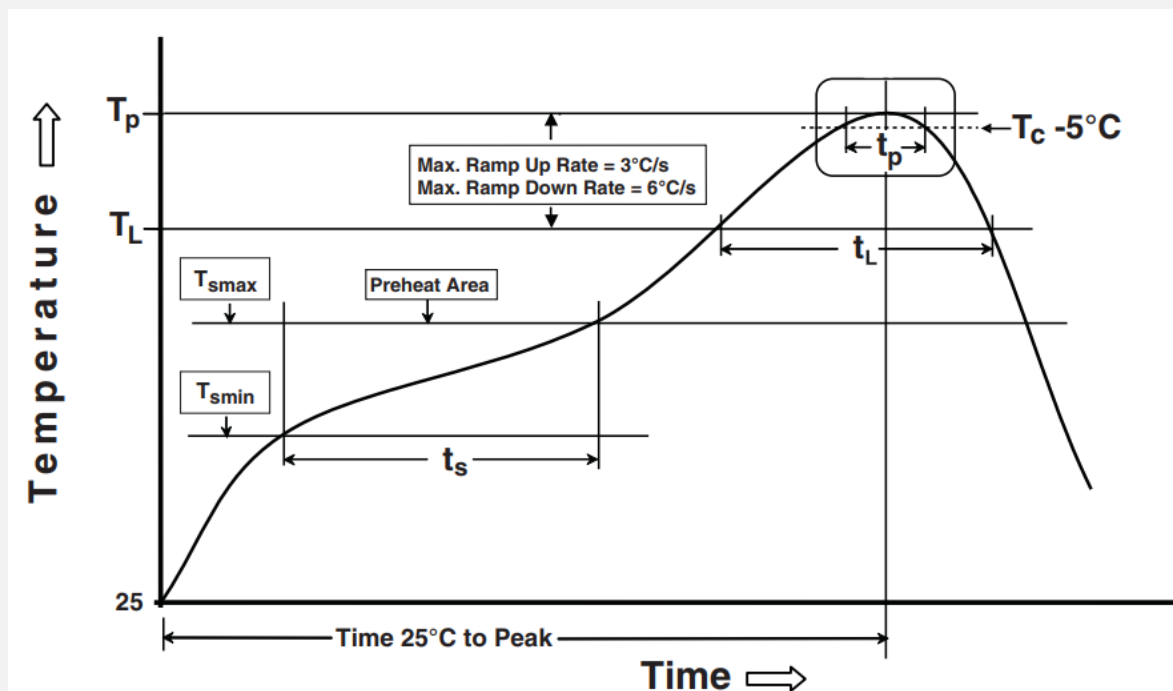
Figure 9 Reflow soldering profile (Refer to IPC/JEDEC J-STD-020E)





8 PRODUCT PACKAGING AND HANDLING

8.1 Packaging

8.1.1 Packaging Notes

TAU1202/TAU1205 GNSS module is a Moisture Sensitive Device (MSD) and Electrostatic Sensitive Device (ESD). During the packing and shipping, it is strictly required to take appropriate MSD handling instructions and precautions. The table below shows the general packing hierarchy for the standard shipment.

Table 13 Packing hierarchy

Module	Reel	Sealed bag	Shipping carton
			

8.1.2 Tape and Reel

The TAU1202/TAU1205 modules are delivered as hermetically sealed, reeled tapes in order to enable efficient production, production lot set-up and tear-down. The figure below shows the tape dimension.

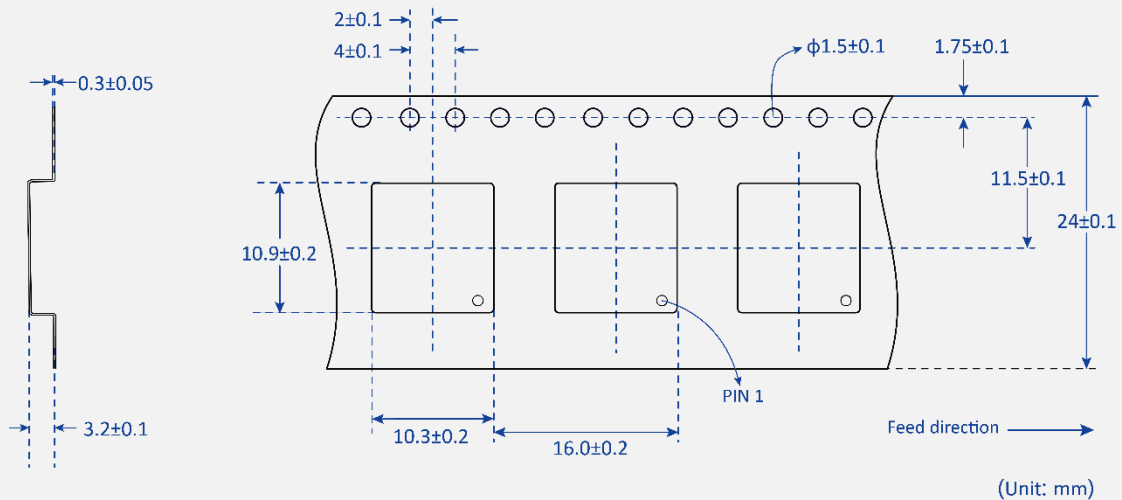

Figure 10 Tape dimensions

TAU1202/TAU1205 are deliverable in quantities of 1000pcs on a reel. The figure below shows the dimensions of reel for TAU1202/TAU1205.

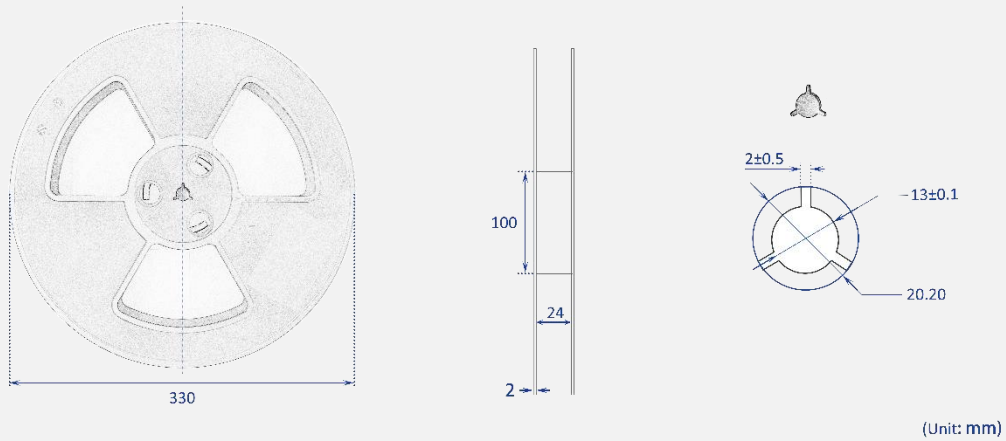

Figure 11 Reel dimensions

8.1.3 Shipment Packaging

The reels of TAU1202/TAU1205 modules are packed in the sealed bags and shipped by shipping cartons. Up to five sealed bags (5000pcs in total) can be packed in one shipping carton.

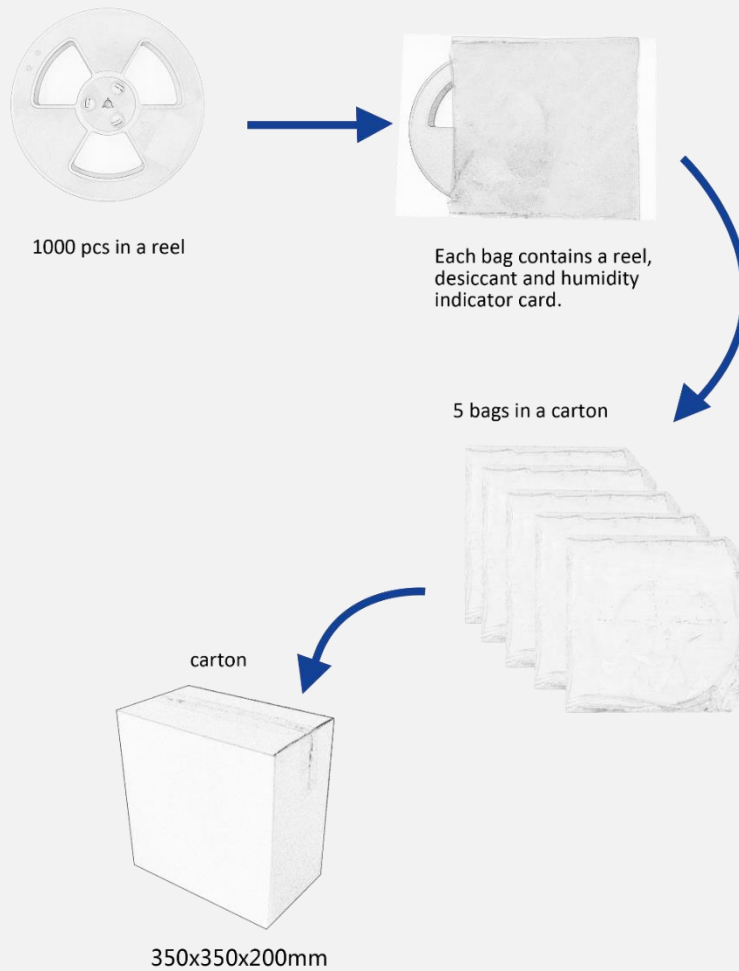

Figure 12 Packaging

8.2 Storage

In order to prevent moisture intake and protect against electrostatic discharge, TAU1202/TAU1205 is packaged together with a humidity indicator card and desiccant to absorb humidity.

8.3 Handling

8.3.1 ESD Handling Precautions

TAU1202/TAU1205 module which contains highly sensitive electronic circuitry is Electrostatic Sensitive Device (ESD). Observe precautions for handling! Failure to observe these precautions may result in severe damage to the GNSS module!

- Unless there is a galvanic coupling between the local GND (i.e. the workbench) and the PCB GND, then the first point of contact when handling the PCB must always be between the local GND and PCB GND.
- Before mounting an antenna patch, connect ground of the device.
- When handling the RF pin, do not come into contact with any charged capacitors and be careful when contacting materials that can develop charges (e.g. patch antenna ~10 pF, coax cable ~50 – 80 pF/m, soldering iron...)
- To prevent electrostatic discharge through the RF input, do not touch any exposed antenna area. If there is any risk that such exposed antenna area is touched in non ESD protected work area, implement proper ESD protection measures in the design.
- When soldering RF connectors and patch antennas to the receiver's RF pin, make sure to use an ESD safe soldering iron (tip).



8.3.2 ESD protection measures

This series of GNSS positioning modules is sensitive to static electricity. Whenever handling the module, particular care must be exercised to reduce the risk of electrostatic charges. In addition to standard ESD safety practices, the following measures should be taken into account.

- Adds ESD Diodes to the RF input part to prevent electrostatics discharge.
- Do not touch any exposed antenna area.
- Adds ESD Diodes to the UART interface.

8.3.3 Moisture sensitivity level

The Moisture Sensitivity Level (MSL) of the GNSS modules is MSL4.

9 LABELING AND ORDERING INFORMATION

Labeling and ordering information help customers get more about Allystar products.

9.1 Labeling

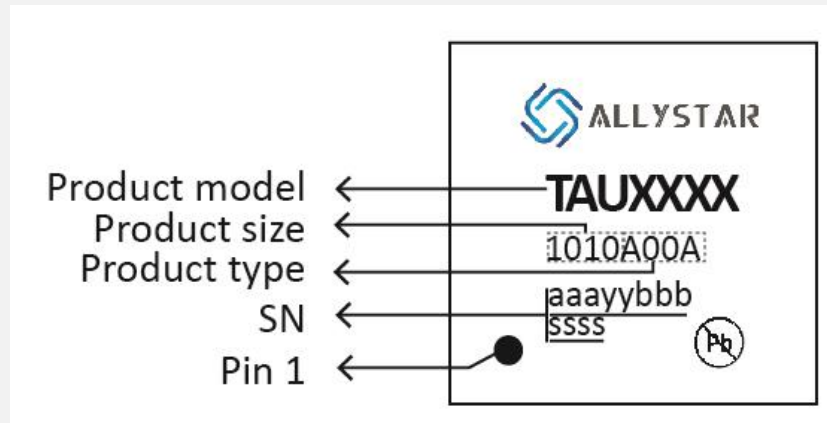

Table 14 Labeling content

Symbol	Explanation	Instance
TAUXXX	Product model	TAU1202
1010A00A	1010 represents the product size.	1010A00
	A00 means the product type.	
	Second A refers to sales area code. Different code for different sales area.	E (for Europe market)
aaayybbbssss	Serial number	361190010001

9.2 Ordering info

Table 15 Ordering codes

Ordering No.	Product
TAU1202-1010A00E	Concurrent GNSS LCC Module, TCXO, ROM, GLONASS, 10.1*9.7mm, 1000 pieces/reel, Europe market
TAU1202-1010A00H	Concurrent GNSS LCC Module, TCXO, ROM, GLONASS, 10.1*9.7mm, 1000 pieces/reel, India market
TAU1202-1010A00R	Concurrent GNSS LCC Module, TCXO, ROM, GLONASS, 10.1*9.7mm, 1000 pieces/reel, Russia market
TAU1205-1010A00E	Concurrent GNSS LCC Module, TCXO, ROM, IRNSS, 10.1*9.7mm, 1000 pieces/reel, Europe market
TAU1205-1010A00H	Concurrent GNSS LCC Module, TCXO, ROM, IRNSS, 10.1*9.7mm, 1000 pieces/reel, India market
TAU1205-1010A00R	Concurrent GNSS LCC Module, TCXO, ROM, IRNSS, 10.1*9.7mm, 1000 pieces/reel, Russia market

10 RELATED DOCUMENTS

- [1] Satrack User Manual
- [2] Allystar Common Commands
- [3] GNSS_Protocol_Specification

11 REVISION HISTORY

Revision	Date	Reviser	Status / Comments
V1.0	2019-05	Daisy	Start version, first released
V1.1	2019-09	Vita Wu	Logo, product photos and wording update
V1.2	2019-12	Vita Wu	Adds packaging info in Section 7; Updates mechanical specification; Updates sensitivity and power consumption in Table 1 and Table 7; Updates antenna gain in Section 4.2; Adds PCB package reference and layout notes in Section 6; Updates Section 6.1;
V1.3	2020-07	Vita Wu	Adds ANT_BIAS info; Adds built-in chock design, and updates reference design; Adds reflow soldering info; Updates mechanical spec; Simplifies Pin description; Other updates;
V1.4	2020-12	Vita Wu	Updates MSL. Improves wordings. Clarifies power on/off sequence. Updates AVDD_BAK connection description in Section 4.1. Updates D-typ and H value in table 11. Localization. Updates layout notes. Deletes 1K resistor in the minimal design diagram. Deletes SBAS support. Updates description about short circuit protection
V1.5	2021-07	Vita Wu	Adds labeling and ordering info. Details default settings. Adds related document list. Adds document info section. Removes C00 design. Updates main voltage range to be 2.0V~3.6V.



ALLYSTAR



www.allystar.com



info.gnss@allystar.com



Headquarters

Allystar Technology (Shenzhen) Co., Ltd.

Address: 5F, Building No.4, Winlead Intelligent Park, No.3, FaDa road (middle), Bantian Subdistrict, LongGang District, Shenzhen City, Guangdong Province, China.

Calgary Office

Allystar Technology (Canada) Ltd.

Address: Unit 288, 3553 31 Street NW Calgary, Alberta, Canada T2L 2K7

