

Oct.1.2021 Copyright 2021 HIROSE ELECTRIC CO., LTD. All Rights Reserved.  
 In case of consideration for using Automotive equipment / device which demand high reliability, kindly contact our sales window correspondents.

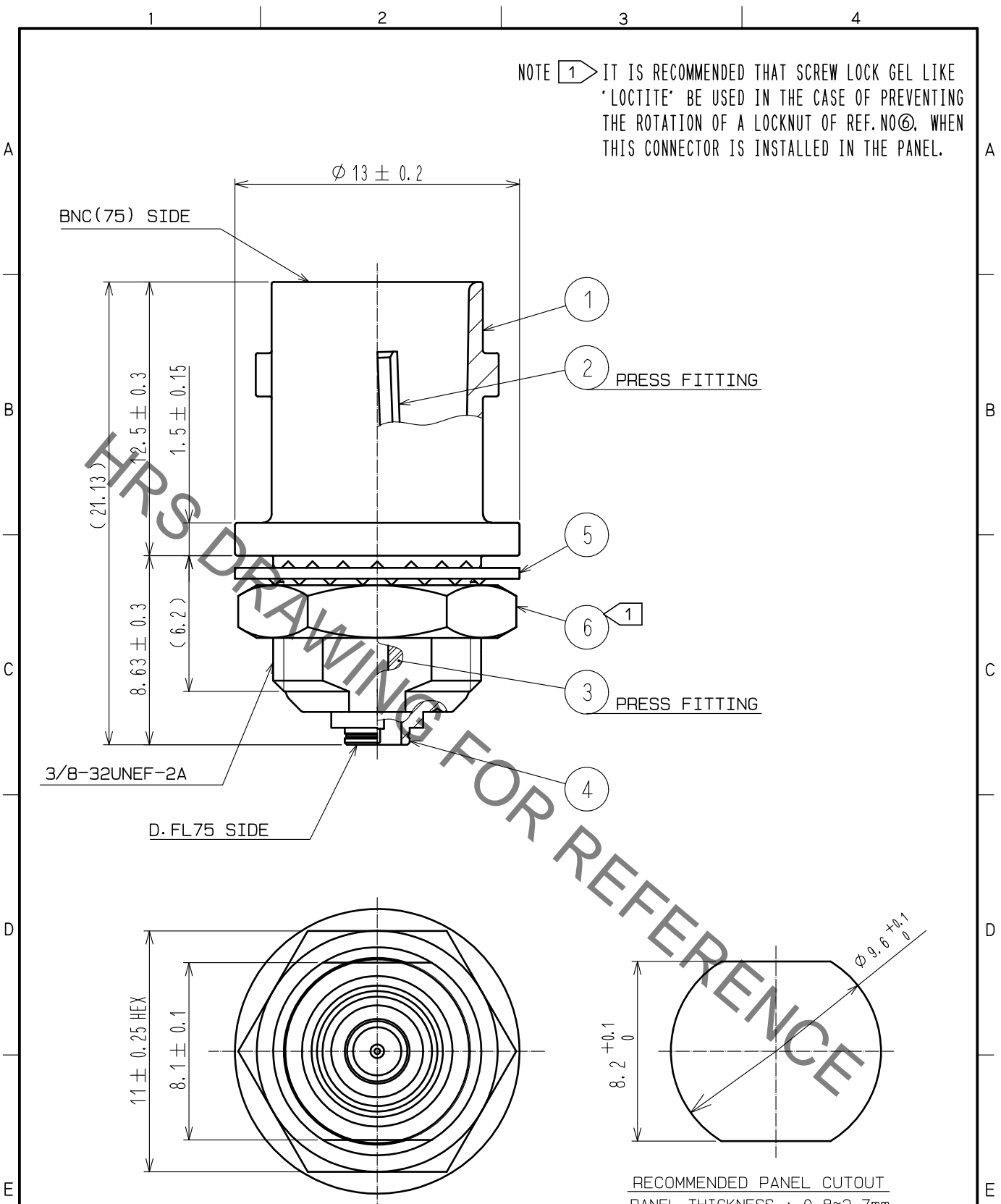

3	PTFE		6	BRASS	NICKEL PLATING
2	BERYLLIUM COPPER	GOLD PLATING	5	STEEL	NICKEL PLATING
1	ZINC ALLOY	NICKEL PLATING	4	BRASS	NICKEL PLATING
NO.	MATERIAL	FINISH . REMARKS	NO.	MATERIAL	FINISH . REMARKS

UNITS mm		SCALE 4 : 1	COUNT 	DESCRIPTION OF REVISIONS	DESIGNED	CHECKED	DATE
<b>HRS</b> HIROSE ELECTRIC CO., LTD.		APPROVED : NK. NINOMIYA	20190215	DRAWING NO.	EDC-375334-00-00		
		CHECKED : NK. NINOMIYA	20190215	PART NO.	BNC(75)J-D. FL75J-BPA		
		DESIGNED : MT. KANEKO	20190215	CODE NO.	CL311-0015-0-00		
		DRAWN : YK. KIUCHI	20190215		1/1		