

| Ver. | Modify No. | Details | Area | P.I.C | Date |
|------|------------|---------|------|-------|------|
| | | | | | |
| | | | | | |
| | | | | | |

Front View

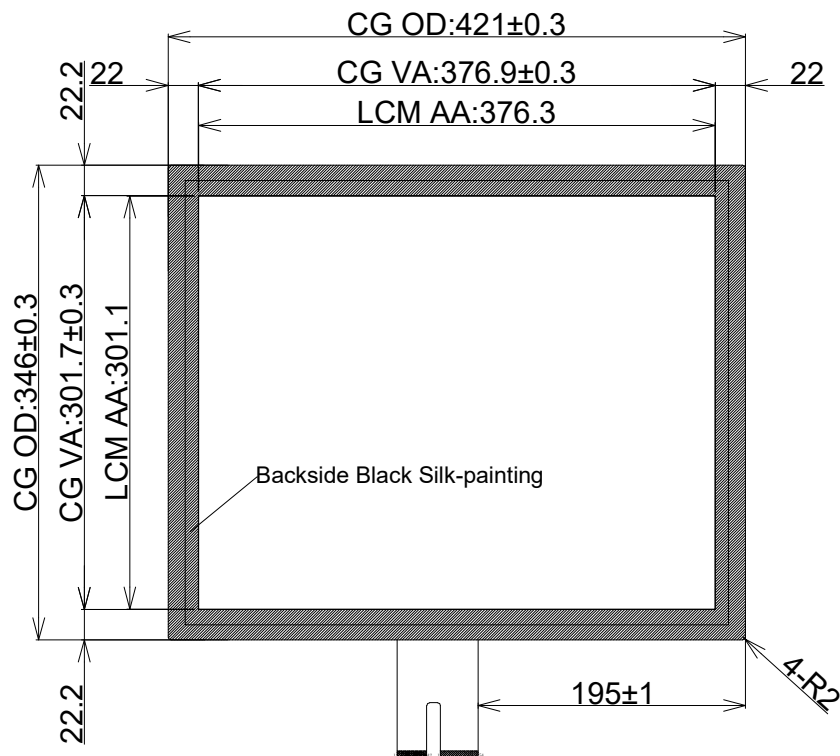

Side View

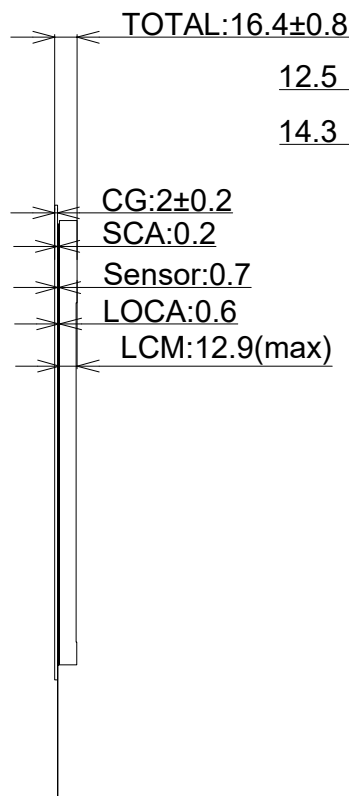

Back View

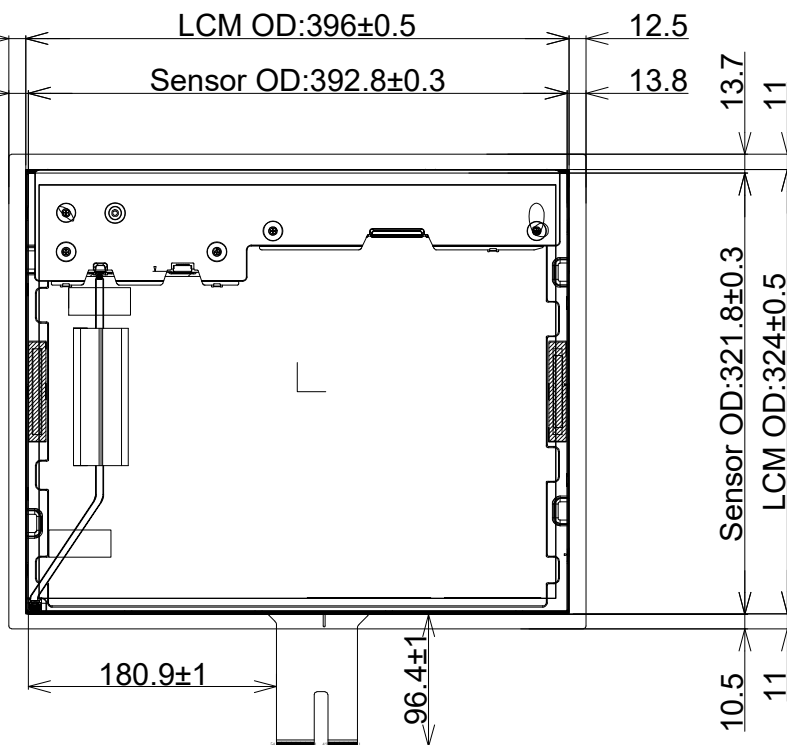

Technical Datasheet:

1. Structure: TP+LCM Optical Bonding
2. Cover Glass: 2mm Tempered Glass
3. LCD: G190ETN01.4
4. TP Controller: BTP-TPM-CTR-ILI-190B-SN10
5. TP Controller IC: ILI2510
6. Surface Hardness: ≥6H
7. Light Transmittance: ≥85%
8. Working Temperature: -20°C~+70°C, ≤85%RH;
9. Storage Temperature: -30°C~+80°C, ≤85%RH;
10. Unmarked Tolerance: ±0.5mm
11. All materials used conform to RoHS standard

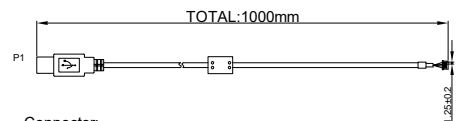
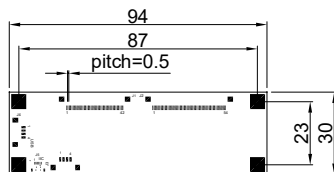

Connector:
 P1: USB Male Connector
 P2: 1.25 Pitch 4pin Connector

| | |
|------------------|------------|
| Designed by: | Curry.Wang |
| Checked by: | Jimmy.Lu |
| Approved by: | Cale.Chen |
| Workmanship: | |
| Standardization: | Link.Chen |
| Released by: | Rocky.Liu |

| | | | | | |
|---|---------|-------------------------------------|-----------------|-------|--|
| Part No. | | BTP-TPM-G1-19-ILI-SN10 | | | |
| Product Name: | | Drawing No. | PM190241019SN10 | | |
| 19 inch Touch Display (TP+LCM Optical Bonding) | | Project Code. | PM190SN10 | | |
| Business Unit: | | Period Mark | View Angle | Ratio | |
| SNT-BTP | | A | | 1:1 | |
| BOM Code | | Page 1 | Total 1 Page | | |
| Product Series | BTP-TPM | 思诺泰科创电子(苏州)有限公司 SINOTRONICS INC. | | | |