



AU Optronics Authorized Distributor

Specification

G\$+\$J HH\$%\$

Revision: \$.2

Preliminary Version: >i `m201'

Preliminary Specification

Final Specification

Module	7 Inch Color TFT-LCD
Model Name	G070VTT01.0

Customer	Date
_____	_____
Checked & Approved by	
_____	_____
<p>Note: This Specification is subject to change without notice.</p>	



Approved by	Date
<u>Grace Hung</u>	<u>2013/04/26</u>
Prepared by	
<u>Christine Huang</u>	<u>2013/04/26</u>
<p>General Display Business Division / AU Optronics corporation</p>	

AUO Confidential For DATA MODUL Internal Use Only / 2013/7/23

Contents

1. Operating Precautions	4
2. General Description.....	5
2.1 Display Characteristics	5
2.2 Optical Characteristics.....	6
2.3.1 FPC Pin Assignment.....	9
2.3.2 Electrical Characteristics	9
2.3.3 Mechanical Characteristics	10
2.3.4 Life Test Condition	10
2.3.5 Attention	11
3. Functional Block Diagram	12
4. Absolute Maximum Ratings	13
4.1 Absolute Ratings.....	13
5. Electrical Characteristics	14
5.1 TFT-LCD Driving	14
5.2 Backlight Unit Driving.....	15
6. Signal Characteristic	16
6.1 Pixel Format Image.....	16
6.2 Scanning Direction.....	16
6.3 The Input Data Format.....	16
6.4 TFT- LCD Interface Signal Description.....	18
6.5 TFT- LCD Interface Timing.....	20
6.6 LED Backlight Unit Interface Signal Description.....	21
6.7 Power ON/OFF Sequence.....	21
7. Connector & Pin Assignment.....	22
7.1 TFT- LCD Panel Pin Assignment :	22
7.2 LED Backlight Pin Assignment :	22
7.3 Touch Panel Pin Assignment :	23
7.4 PIN 1 definition.....	24
8. Reliability Test Criteria.....	25
9. Mechanical Characteristics.....	26
10. Label and Packaging	28
10.1 Shipping Label (on the rear side of TFT-LCD display)	28
10.2 Carton Package.....	28
11 Safety.....	29
11.1 Keen Edge Requirements	29
11.2 Materials	29
11.3 Capacitors	29
11.4 National Test Lab Requirement	29

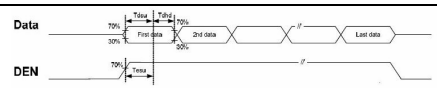
Record of Revision

Version and Date	Page	Old description	New Description	Remark
V 0.1 Apr. 26, 2013	All	First Edition		
V 0.2 Apr. 30, 2013	5	Typical Power Consumption 2.18W (LCD:0.5W/LED BLU: 1.68W(Max.)) @ All black pattern, Full Load and V _{LED} =12V	Typical Power Consumption TBD W (LCD:TBD W/LED BLU: 1.68W(Max.)) @ All black pattern, Full Load and V _{LED} =12V	Section 2.1
	10	Operation Force (Pen or Finger) Min. 60gf	Operation Force (Pen or Finger) Max. 100gf	Section 2.3.3
	14	Absolute Ratings of Environment	Remove Absolute Ratings of Environment	Section 4.2
	20	Data  DEN 	Remove the mistaken timing diagram	Section 6.5
	25	Vibration Test(Non-Operating): Sine wave : 6.8G , 10~400Hz , 280mins/axis , 0.6oct/min Random : 3.3Grms , 5-500Hz , 30mins/axis	Vibration Test(Non-Operating): 1.5G, (10~200~10Hz, P-P), 30 mins/axis (X, Y, Z)	Section 8

AUO Confidential For DATAMODUL Internal Use Only / 2013/7/23

1. Operating Precautions

- 1) Display area (Polarizer) of TFT-LCD Module is easily to be damaged, please be cautious and not to scratch it.
- 2) Be sure to power off your machine before connecting or disconnecting your signal cable to TFT-LCD Module.
- 3) Wipe off water drop on display area immediately. Long contact with water may cause discoloration or spots.
- 4) When the panel surface is soiled, wipe it with absorbent cotton or soft cloth.
- 5) Display area (Glass) of TFT-LCD Module may be broken or cracked if bump Module against hard object.
- 6) To avoid ESD (Electro Static Discharge) damage, be sure to ground yourself before handling TFT-LCD Module.
- 7) Do not open nor modify the TFT-LCD module assembly.
- 8) Do not press the reflector sheet at the back of the module to any direction.
- 9) In case if TFT-LCD module has to be put back into the packing container slot after it was taken out from the container, do not press the center of the LED Reflector edge. Instead, press at the far ends of the LED Reflector edge softly. Otherwise the TFT-LCD Module may be damaged.
- 10) When inserting or removing of your signal cable to TFT-LCD Module, be sure not to apply abnormal force (rotate, tilt... etc.) to the Connector of the TFT-LCD Module.
- 11) TFT-LCD Module is not allowed to be twisted & bent even force is added on module in a very short time. Please design your display product well to avoid external force applying to module by end-user directly.
- 12) Small amount of materials without flammability grade are used in the TFT-LCD module. The TFT-LCD module should be supplied by power complied with requirements of Limited Power Source (IEC60950 or UL1950), or be applied exemption.
- 13) Severe temperature condition may result in different luminance, response time.
- 14) Continuous operating TFT-LCD Module under high temperature environment may accelerate LED light bar exhaustion and reduce luminance dramatically.
- 15) The data on this specification sheet is applicable when TFT-LCD module is placed in landscape position.
- 16) Continuous displaying fixed pattern may induce image sticking. It's recommended to use screen saver or moving content periodically if fixed pattern is displayed on the screen.

2. General Description

G070VTT01.0 is designed for industrial display applications with WVGA (800 x RGB x 480) resolution and 262k colors (RGB 6-bits). It is composed of a TFT-LCD panel, resistive touch and LED backlight unit. G070VTT01.0 offers Digital RGB interface for display signal input.

2.1 Display Characteristics

The following items are G070VTT01.0 characteristics summary at 25 °C (Room Temperature).

Items	Unit	Specifications
Screen Diagonal	inch	7
Active Area	mm	152.4(H) x 91.44(V)
Pixels H x V		800 x 480(RGB)
Pixel Pitch	mm	0.1905 x 0.1905
Pixel Arrangement		R.G.B. Horizontal Stripe
Display Mode		TN, Normally White
Nominal Input Voltage VDD	Volt	3.3 typ.
Typical Power Consumption	Watt	TBD W (LCD:TBD W/LED BLU: 1.68W(Max.)) @ All black pattern, Full Load and V _{LED} =12V
Weight	Grams	TBDg (typ.), TBDg (max.)
Physical Size	mm	165.0(H)x 105.8(V) x 4.51(D) (typ.)
Electrical Interface		Parallel RGB
Surface Treatment		Anti-Glare, Hardness 3H
Support Color		262K colors
The most suitable view angle		6 o'clock
Temperature Range		
Operating	°C	-20 to +70
Storage (Non-Operating)	°C	-30 to +80
RoHS Compliance		RoHS Compliance

AUO Confidential For DATAMODUL Internal Use Only 10170123

2.2 Optical Characteristics

The optical characteristics are measured under stable conditions at 25°C (Room Temperature).

Item	Unit	Conditions	Min.	Typ.	Max.	Remark
White Luminance	cd/m ²	V _{LED} =12V, D _{PWM} =100% (center point)	250	360	-	Note 1
Uniformity	%	9 Points	70	75		Note 1, 2, 3
Contrast Ratio			400	500	-	Note 4
Response Time	msec	Rising	-	12	20	Note 5
	msec	Falling	-	18	30	
	msec	Rising + Falling	-	30	50	
Viewing Angle	degree degree	Horizontal (Right) CR = 10 (Left)	55 55	65 65	- -	Note 6
	degree degree	Vertical (Upper) CR = 10 (Lower)	40 50	50 60	- -	
Color / Chromaticity Coordinates (CIE 1931)		White x	TBD	TBD	TBD	
		White y	TBD	TBD	TBD	
		Red x	TBD	TBD	TBD	
		Red y	TBD	TBD	TBD	
		Green x	TBD	TBD	TBD	
		Green y	TBD	TBD	TBD	
		Blue x	TBD	TBD	TBD	
		Blue y	TBD	TBD	TBD	
Color Gamut	%		-	50	-	

Note 1: Measurement method

- Equipment Pattern Generator, Power Supply, Digital Voltmeter, Luminance meter (SR_3 or equivalent)
- Aperture 1" with 50cm viewing distance
- Test Point Center
- Environment < 1 lux

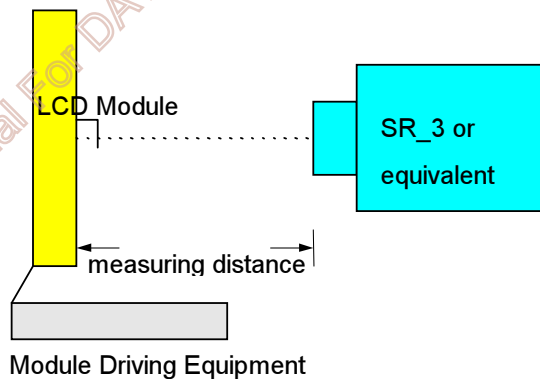

Note 2: Definition of 9 points position (Display active area: 152.4mm(H) x 91.44mm(V))

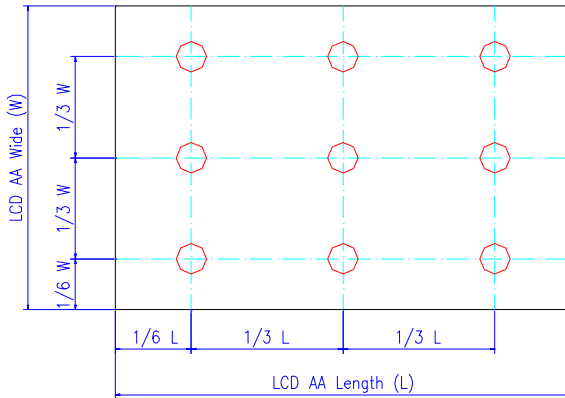

Note 3:

The luminance uniformity of 9 points is defined by dividing the maximum luminance value by the minimum luminance value at full white condition.

$$\text{Uniformity} = \frac{\text{minimum luminance in 9 points (1-9)}}{\text{maximum luminance in 9 points (1-9)}}$$

Note 4:

Definition of contrast ratio (CR):

$$\text{Contrast ratio (CR)} = \frac{\text{Brightness @ "White" state}}{\text{Brightness @ "Black" state}}$$

Note 5: Definition of response time:

The output signals of photo detector are measured when the input signals are changed from "White" to "Black" (falling time) and from "Black" to "White" (rising time), respectively. The response time interval definition is between 10% and 90% of amplitude. Please refer to the figure as below.

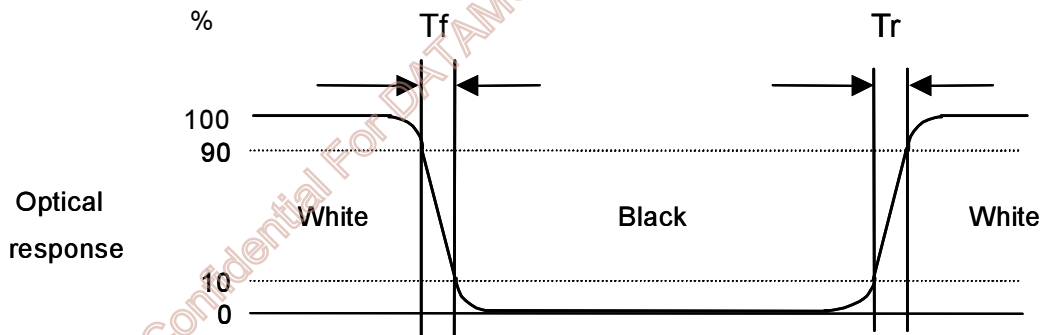

Note 6: Definition of viewing angle

Viewing angle is the measurement of contrast ratio ≥ 10 , at the screen center, over 180° horizontal and 180° vertical range. The 180° horizontal (θ_L, θ_R) and 180° vertical (ϕ_H, ϕ_L) range are illustrated as following figure.

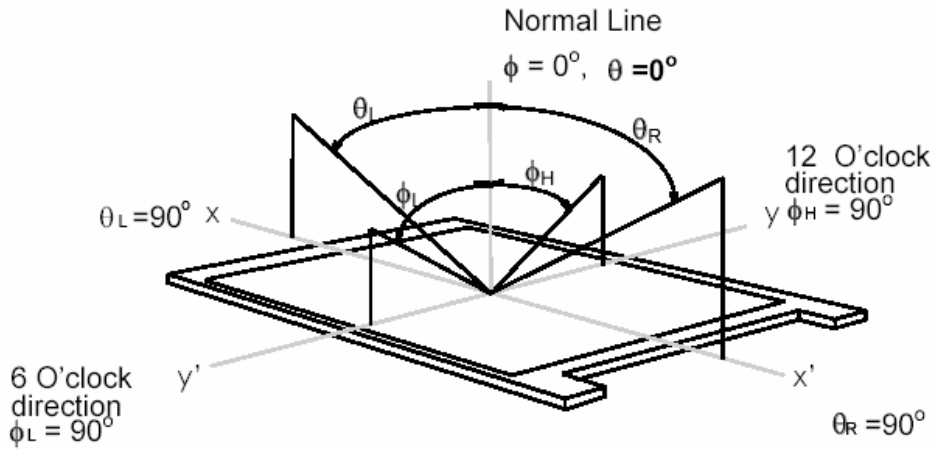

AUO Confidential For DATAMODUL Internal Use Only / 2013/7/23

2.3 Touch Characteristics

2.3.1 FPC Pin Assignment

Pin No.	Symbol	I/O	Description
1	XL	I/O	Touch panel left electrode (R)
2	YB	I/O	Touch panel bottom electrode (B)
3	XR	I/O	Touch panel right electrode (L)
4	YU	I/O	Touch panel top electrode (U)

2.3.2 Electrical Characteristics

Item	Min.	Typ.	Max.	Unit	Remark
Rate DC Voltage	--	--	7	V	
Resistance	X (Film)	TBD	--	TBD	Ω At connector
	Y (Glass)	TBD	--	TBD	
Linearity	-1.5%		1.5%	--	Note 1
Response Time			20	ms	
Insulation Resistance	20			M Ω	DC 25V

Note 1: Measurement condition of Linearity: difference between actual voltage & theoretical voltage is an error at any points. Linearity is the value max. error voltage divided by voltage difference on within T/P active area inside 2mm.

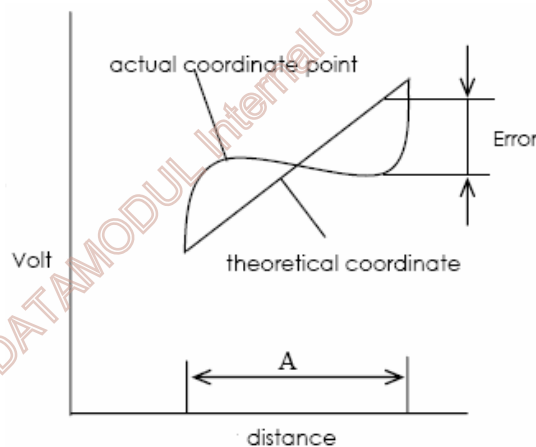

2.3.3 Mechanical Characteristics

Item	Min.	Max.	Unit	Remark
Hardness of Surface	3	-	H	JIS K-5600
Operation Force (Pen or Finger)	-	100	gf	Note 1, 2
Transparent	-	80	%	

Note 1: Within "active area inside 2mm", but not near the active area boundary and on the dot-spacer.
 Note 2: Operation force measurement is under test condition as figure below.

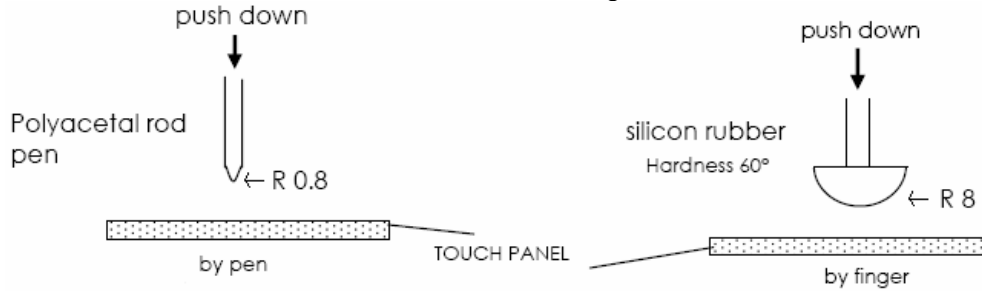

2.3.4 Life Test Condition

Item	Min.	Max.	Unit	Remark
Notes Life	10^5	--	lines	Note 1, 2
Input Life	10^6	--	times	Note 1, 3

Note 1: Notes Life test condition (by pen): slide on central 2/3 of active area and use R 0.8mm polyacetal pen, input force: 250gf, frequency: 60mm/sec. Sliding from A to B complete 1 time. shown as figure.

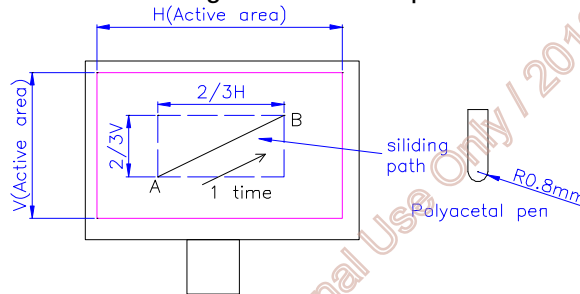

Note 2: Input Life test condition (by finger): test position on active area center and use R8.0mm silicon rubber (hardness 60°), test force: 250gf, frequency: 2times/sec. shown as figure.

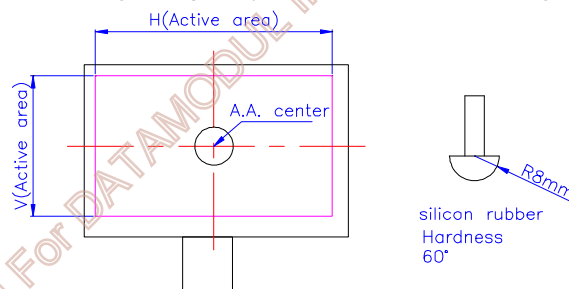

AUO Confidential For DATAMODUL Internal Use Only | 2013/7/23

2.3.5 Attention

Please pay attention for below matters at mounting design for touch panel of LCD module.

- 1) To prevent abnormal work on touch function, casing and T/P ITO film should have a gap.
Suggestion design show as below figure.
- 2) Cushion area and casing opening must be followed mechanical drawing.
- 3) Don't use glue, hard or conductive material as a cushion to enclosure touch panel.
- 4) The touch panel edge is conductive. Do not touch it with any conductive part after mounting.

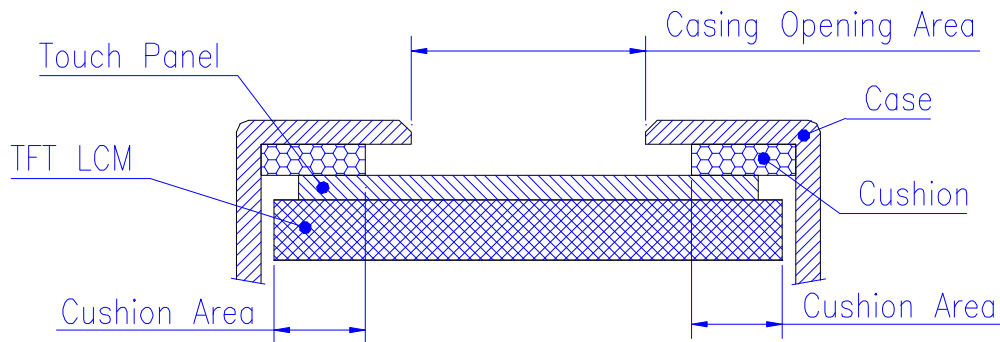

- 5) If users want to cleaning touch panel by air gun, pressure $2\text{kg}/\text{cm}^2$ below is suggested.
- 6) Do not input with a heavy shock or stress on touch panel and film surface. Ex. Don't transfer the panel from film face with vacuum.
- 7) Do not lift LCD module by FPC.
- 8) Please use dry cloth or soft cloth with neutral detergent (after wring dry) or one with ethanol at cleaning. Do not use any organic solvent, acid or alkali solution.
- 9) Do not pile touch panels. Do not put heavy goods on touch panels.

AUO Confidential For DATAMODUL Internal Use Only / 2013/7/23

3. Functional Block Diagram

The following diagram shows the functional block of the G070VTT01.0 color TFT/LCD module.

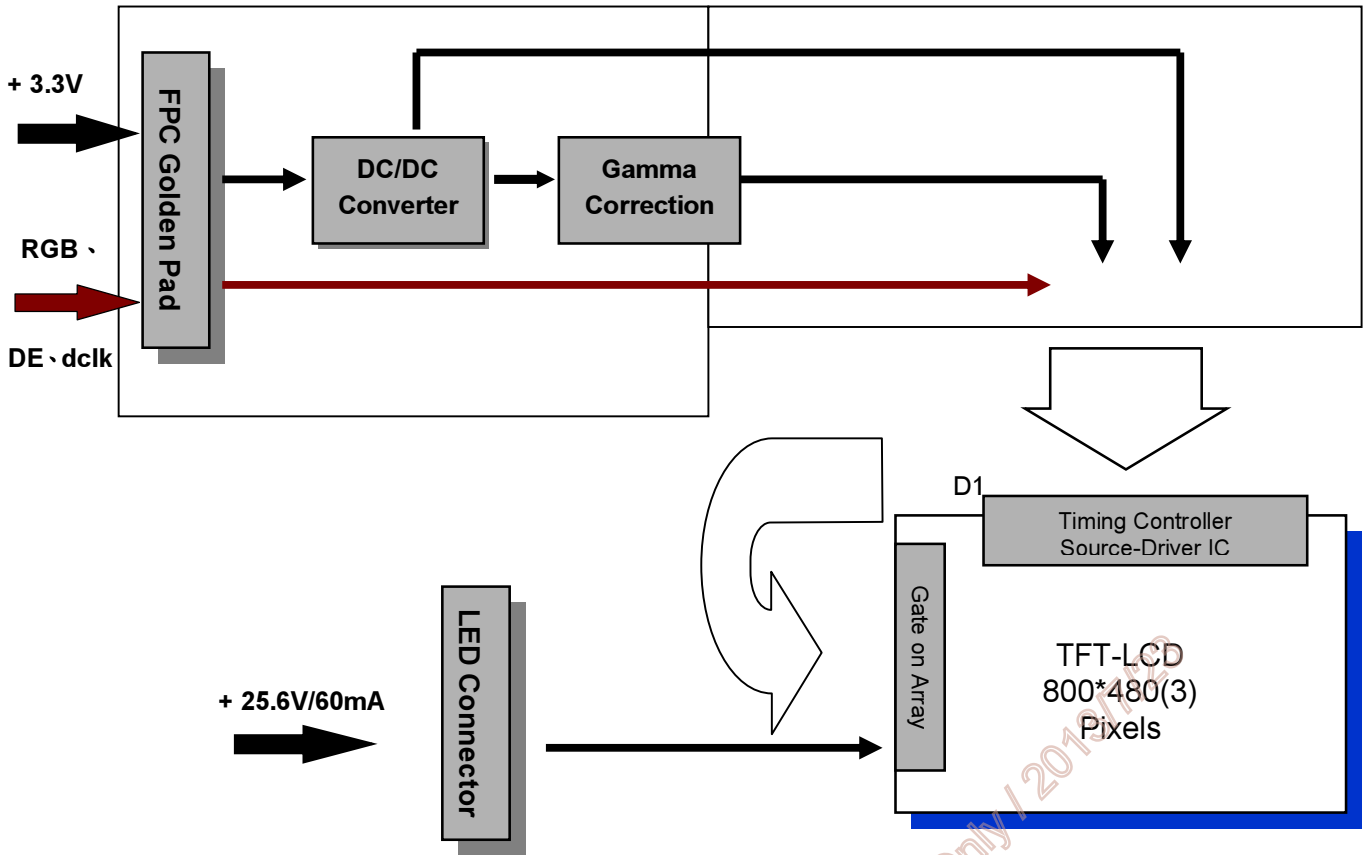

AUO Confidential For DATAMODUL Internal Use Only / 2017.11.16

4. Absolute Maximum Ratings

4.1 Absolute Ratings

Item	Symbol	Condition	Min.	Max.	Unit	Remark
Power voltage	VCC	GND=0	-0.5	5	V	
LED Reverse Voltage	V_r		0	3.55	Volt	Ta= 25°C
LED Forward Current	I_f		0	25	mA	Ta= 25°C
Input signal voltage	V_i	GND=0	-0.3	VCC+0.3	V	Note 1

AUO Confidential For DATAMODUL Internal Use Only / 2013/7/23

5. Electrical Characteristics

5.1 TFT-LCD Driving

5.1.1 Power Specification

Symbol	Parameter	Min	Typ	Max	Units	Remark
VCC	Logic/LCD Drive Voltage	3.0	3.3	3.6	Volt	
I _{VCC}	VCC Current	-	TBD	TBD	mA	64 Gray Bar Pattern (VCC=3.3V, at 60Hz)
I _{rush}	LCD Inrush Current	-	TBD	TBD	A	Note1
P _{VCC}	VCC Power	-	-	TBD	Watt	64 Gray Bar Pattern (VCC=3.3V, at 60Hz)

Note 1: Measurement condition:

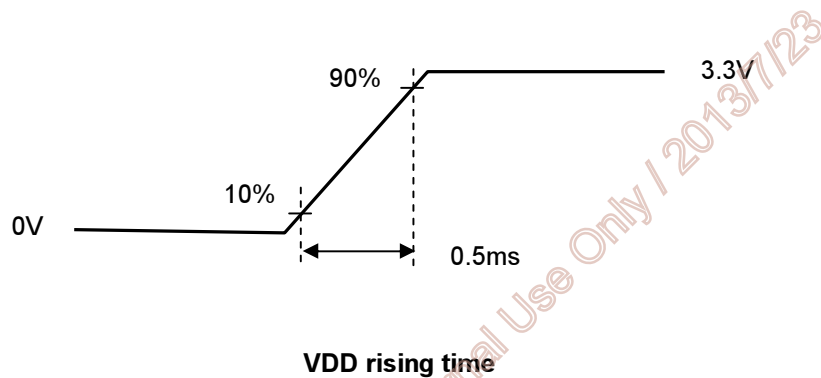

5.1.2 Signal Electrical Characteristics

Input signals shall be low or Hi-Z state when VCC is off.

Parameter	Symbol	Min.	Typ.	Max.	Unit	Remarks
Logic Input Voltage for Display Signals	High	V _{IH}	0.7VCC	-	VCC	Volt
	Low	V _{IL}	0	-	0.3VCC	Volt

5.2 Backlight Unit Driving

5.2.1 Parameter guideline for LED

Following characteristics are measured under stable condition using a LED driving board at 25°C (Room Temperature)

Symbol	Parameter	Min	Typ	Max	Units	Remark
V_{LED}	Input Voltage		25.6	28	Volt	Note 3
I_{LED}	Input Current	-	60	66	mA	Note 3
P_{LED}	Power Consumption	-	1.536	1.848	Watt	
I_F	LED Forward Current		20	22	mA	Ta = 25°C, each string
V_F	LED Forward Voltage		25.6	28		Ta = 25°C, each string
P_{LED}	LED Power		0.512	0.56	Watt	Ta = 25°C, each string
Operating Life		10000	-	-	Hrs	Note 1, 2

Note 1: If G070VTT01.0 module is driven by high current or at high ambient temperature & humidity condition. The operating life will be reduced.

Note 2: Operating life means brightness goes down to 50% initial brightness. Minimum operating life time is estimated data.

Note 3: See Section 6.6 for LED Backlight Unit Interface Signal Description

Note 4: LED backlight is 24 LEDs serial type. Suggestion is driven by current 20mA for each LED string.

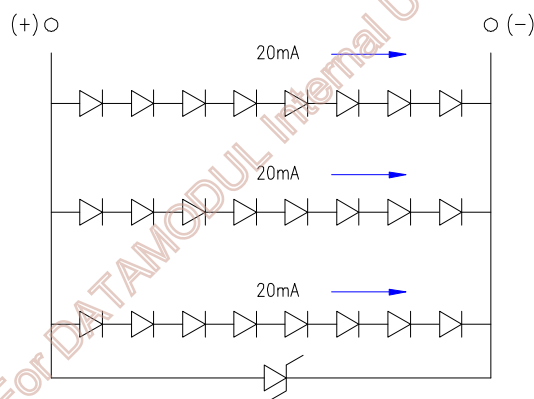

6. Signal Characteristic

6.1 Pixel Format Image

Following figure shows the relationship between input signal and LCD pixel format.

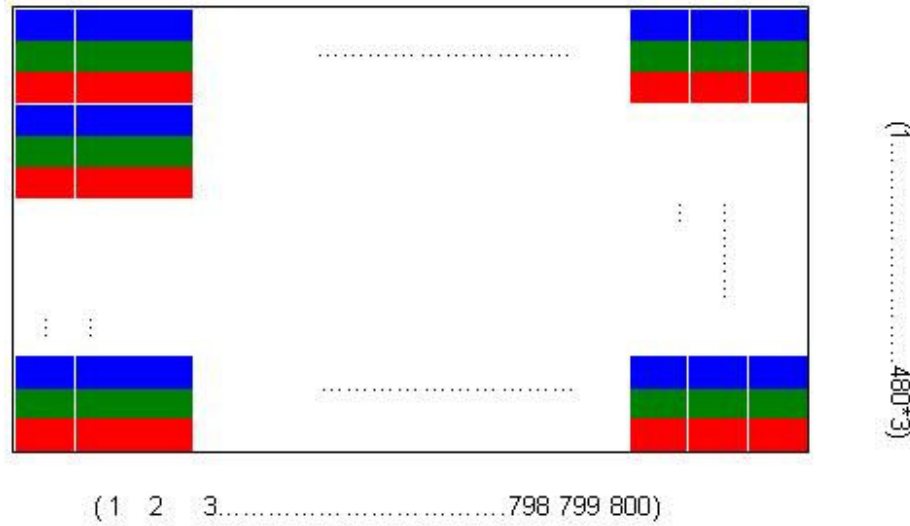

6.2 Scanning Direction

The following figures show the image seen from the front view. The arrow indicates the direction of scan.

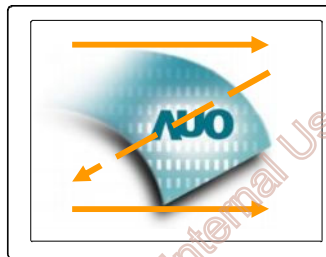

6.3 The Input Data Format

This product displays 262,144 colors in terms of the 64 grey levels on RGB respectively. The following table demonstrates the display of input data.

AUO Confidential For DATAMODUL Internal Use Only / 2013/7/23

Display colors		Data signal (0 : Low level, 1: High level)																	
		R5	R4	R3	R2	R1	R0	G5	G4	G3	G2	G1	G0	B5	B4	B3	B2	B1	B0
Basic colors	Black	0	0	0	0	0	0	0	0	0	0	0	0	0	0	0	0	0	0
	Blue	0	0	0	0	0	0	0	0	0	0	0	0	1	1	1	1	1	1
	Red	1	1	1	1	1	1	0	0	0	0	0	0	0	0	0	0	0	0
	Magenta	1	1	1	1	1	1	0	0	0	0	0	0	1	1	1	1	1	1
	Green	0	0	0	0	0	0	1	1	1	1	1	1	0	0	0	0	0	0
	Cyan	0	0	0	0	0	0	1	1	1	1	1	1	1	1	1	1	1	1
	Yellow	1	1	1	1	1	1	1	1	1	1	1	1	0	0	0	0	0	0
	White	1	1	1	1	1	1	1	1	1	1	1	1	1	1	1	1	1	1
Red grayscale	Black	0	0	0	0	0	0	0	0	0	0	0	0	0	0	0	0	0	0
	Dark	0	0	0	0	0	1	0	0	0	0	0	0	0	0	0	0	0	0
	↑																		
	↓																		
	bright	1	1	1	1	0	1	0	0	0	0	0	0	0	0	0	0	0	0
	Red	1	1	1	1	1	0	0	0	0	0	0	0	0	0	0	0	0	0
Green grayscale	Black	0	0	0	0	0	0	0	0	0	0	0	0	0	0	0	0	0	0
	Dark	0	0	0	0	0	0	0	0	0	0	1	0	0	0	0	0	0	0
	↑																		
	↓																		
	bright	0	0	0	0	0	0	1	1	1	1	0	1	0	0	0	0	0	0
	Green	0	0	0	0	0	0	1	1	1	1	1	1	0	0	0	0	0	0
Blue grayscale	Black	0	0	0	0	0	0	0	0	0	0	0	0	0	0	0	0	0	0
	Dark	0	0	0	0	0	0	0	0	0	0	0	0	0	0	0	0	0	1
	↑																		
	↓																		
	bright	0	0	0	0	0	0	0	0	0	0	0	0	1	1	1	1	0	1
	Blue	0	0	0	0	0	0	0	0	0	0	0	0	1	1	1	1	1	1

AUO Confidential For DATAMODUL Internal Use Only 120137123

6.4 TFT- LCD Interface Signal Description

Pin No.	Symbol	I/O	Description
1	GND	P	Ground for LCD
2	GND	P	Ground for LCD
3	NC	NC	Not connect
4	VCC	P	Supply voltage for LCD
5	VCC	P	Supply voltage for LCD
6	VCC	P	Supply voltage for LCD
7	VCC	P	Supply voltage for LCD
8	NC	NC	Not connect
9	DE	I	Data enable Input
10	GND	P	Ground for LCD
11	GND	P	Ground for LCD
12	GND	P	Ground for LCD
13	B5	I	Blue data input (MSB)
14	B4	I	Blue data input
15	B3	I	Blue data input
16	GND	P	Ground for LCD
17	B2	I	Blue data input
18	B1	I	Blue data input
19	B0	I	Blue data input(LSB)
20	GND	P	Ground for LCD
21	G5	I	Green data input (MSB)
22	G4	I	Green data input
23	G3	I	Green data input
24	GND	P	Ground for LCD
25	G2	I	Green data input
26	G1	I	Green data input
27	G0	I	Green data input(LSB)
28	GND	P	Ground for LCD
29	R5	I	Red data input (MSB)
30	R4	I	Red data input
31	R3	I	Red data input
32	GND	P	Ground for LCD
33	R2	I	Red data input
34	R1	I	Red data input

35	R0	I	Red data input
36	GND	P	Ground for LCD
37	GND	P	Ground for LCD
38	DCLK	I	Data clock Input
39	GND	P	Ground for LCD
40	GND	P	Ground for LCD

I: Input; P: Power; NC : Not connect

AUO Confidential For DATAMODUL Internal Use Only / 2013/7/23

6.5 TFT- LCD Interface Timing

6.5.1 Timing Characteristics

DE mode only

PARAMETER	SYMBOL	MIN.	TYP.	MAX.	UNIT	Remark
DCLK frequency	F_{DCLK}	30.3	33.26	37.8	MHz	
Hsync period ($T_h = T_{hd} + T_{hbl}$)	T_h	1000	1056	1112	T_{DCLK}	
Active Area (T_{hd})	T_{hd}	--	800	--	T_{DCLK}	
Horizontal blanking (T_{hbl})	T_{hbl}	200	256	312	T_{DCLK}	
Vsync period ($T_v = T_{vd} + T_{vbl}$)	T_v	517	525	532	Th	
Active lines (T_{vd})	T_{vd}	--	480	--	Th	
Vertical blanking (T_{vbl})	T_{vbl}	37	45	52	Th	

Note 1: Recommended frame rate is 60 Hz.

6.5.2 Input Timing Diagram

Vertical timing:

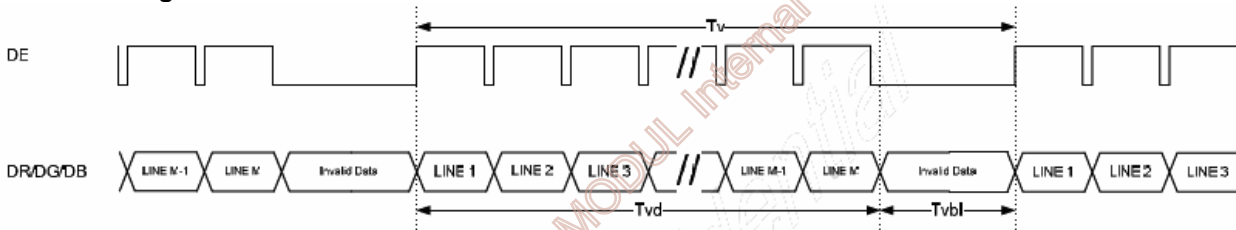

Horizontal timing:

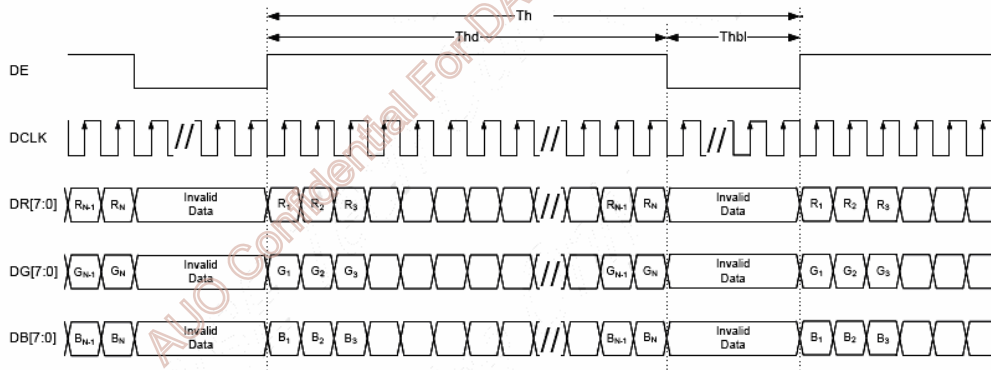

Note: horizontal resolution $N = 800$

Note: vertical resolution $M = 480$

6.6 LED Backlight Unit Interface Signal Description

Pin #	Symbol	Pin Description
1	LED1	LED Cathode
2	VLED	LED Anode
3	LED2	LED Cathode
4	VLED	LED Anode
5	LED3	LED Cathode
6	VLED	LED Anode

Note 1: "NC" stands for "No Connection"

6.7 Power ON/OFF Sequence

VCC power, LCD interface signals and backlight on/off sequence are shown in the following chart. Signals from any system shall be Hi-Z state or low level when VCC is off.

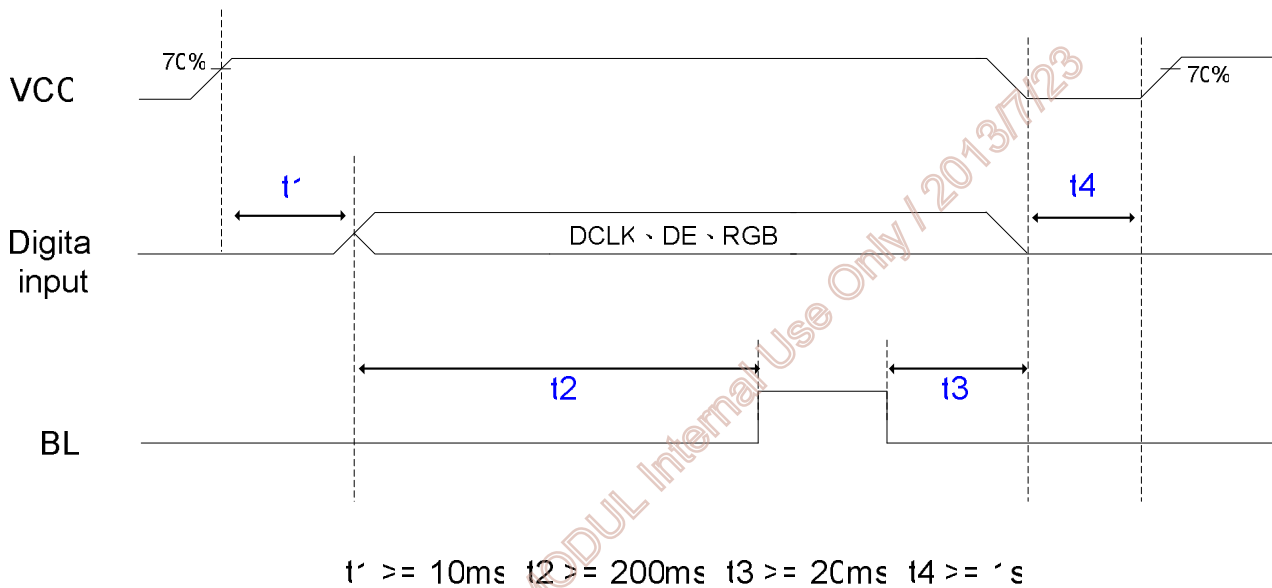

ON/OFF sequence should be applied to avoid abnormal function in the display. Please make sure to turn off the power when you plug the cable into the input connector or pull the cable out of the connector.

7. Connector & Pin Assignment

7.1 TFT- LCD Panel Pin Assignment:

Recommended connector : HIROSE FH12-40S-0.5SH

Pin#	Symbol	Pin#	Symbol
1	GND	21	G5
2	GND	22	G4
3	NC	23	G3
4	VCC	24	GND
5	VCC	25	G2
6	VCC	26	G1
7	VCC	27	G0
8	NC	28	GND
9	DE	29	R5
10	GND	30	R4
11	GND	31	R3
12	GND	32	GND
13	B5	33	R2
14	B4	34	R1
15	B3	35	R0
16	GND	36	GND
17	B2	37	GND
18	B1	38	DCLK
19	B0	39	GND
20	GND	40	GND

7.2 LED Backlight Pin Assignment:

Recommended connector: KYCOERA ELCO 04-6277-006-001-883+

Pin #	Symbol	Pin #	Symbol
1	LED1	2	VLED
3	LED2	4	VLED
5	LED3	6	VLED

7.3 Touch Panel Pin Assignment:

Recommended connector: KYOCERA ELCO 04-6227-004-100-829+

Pin #	Symbol	Pin Description
1	Left	Touch panel left electrode (R)
2	Bottom	Touch panel bottom electrode (B)
3	Right	Touch panel right electrode (L)
4	Top	Touch panel top electrode (U)

AUO Confidential For DATAMODUL Internal Use Only / 2013/7/23

7.4 PIN 1 definition

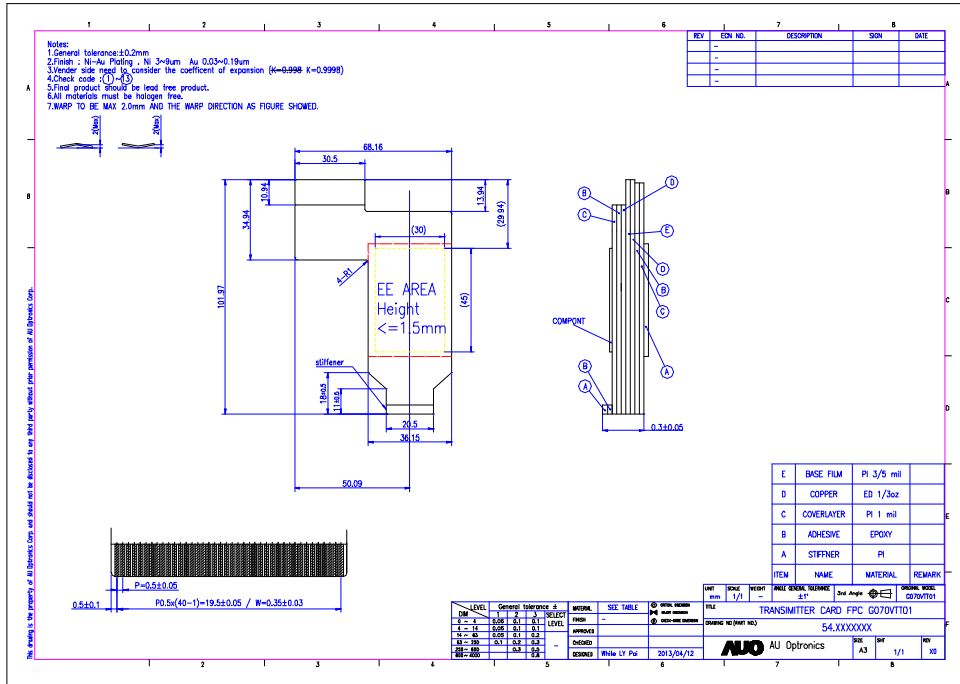

AUO Confidential For DATAMODUL Internal Use Only / 2013/7/23

8. Reliability Test Criteria

Items	Required Condition	Remark
Temperature Humidity Bias	40□/90%,300Hr	Note 2
High Temperature Operation	70□,300Hr	Note 2
Low Temperature Operation	-20□,300Hr	Note 2
High Temperature Storage	80□,300 hours	Note 2
Low Temperature Storage	-30°C,300 hours	Note 2
Thermal Shock Test	-20°C/30 min ,60°C/30 min ,100cycles	Note 2
Shock Test (Non-Operating)	50G, 20ms, Half-sine wave, (±X, ±Y, ±Z)	Note 2
Vibration Test (Non-Operating)	1.5G, (10~200~10Hz, P-P), 30 mins/axis (X, Y, Z)	Note 2
ESD	Contact Discharge: ±8KV, 150pF(330Ω) 1sec, 8 points, 25 times/point Air Discharge: ±15KV, 150pF(330Ω) 1sec, 8 points, 25 times/point	Note 1,2

Note1: According to EN61000-4-2 ESD class B criteria, some performance degradation is allowed. TFT-LCD module is self-recoverable, no data lost and no hardware failures after test.

Note2:

- Water condensation is not allowed for each test items.
- Each test is done by new TFT-LCD module. Don't use the same TFT-LCD module repeatedly for reliability test.
- The reliability test is performed only to examine the TFT-LCD module capability.
- To inspect TFT-LCD module after reliability test, please store it at room temperature and room humidity for 24 hours at least in advance.

AUO Confidential For DATAMODUL Internal Use Only / 2013/7/23

9. Mechanical Characteristics

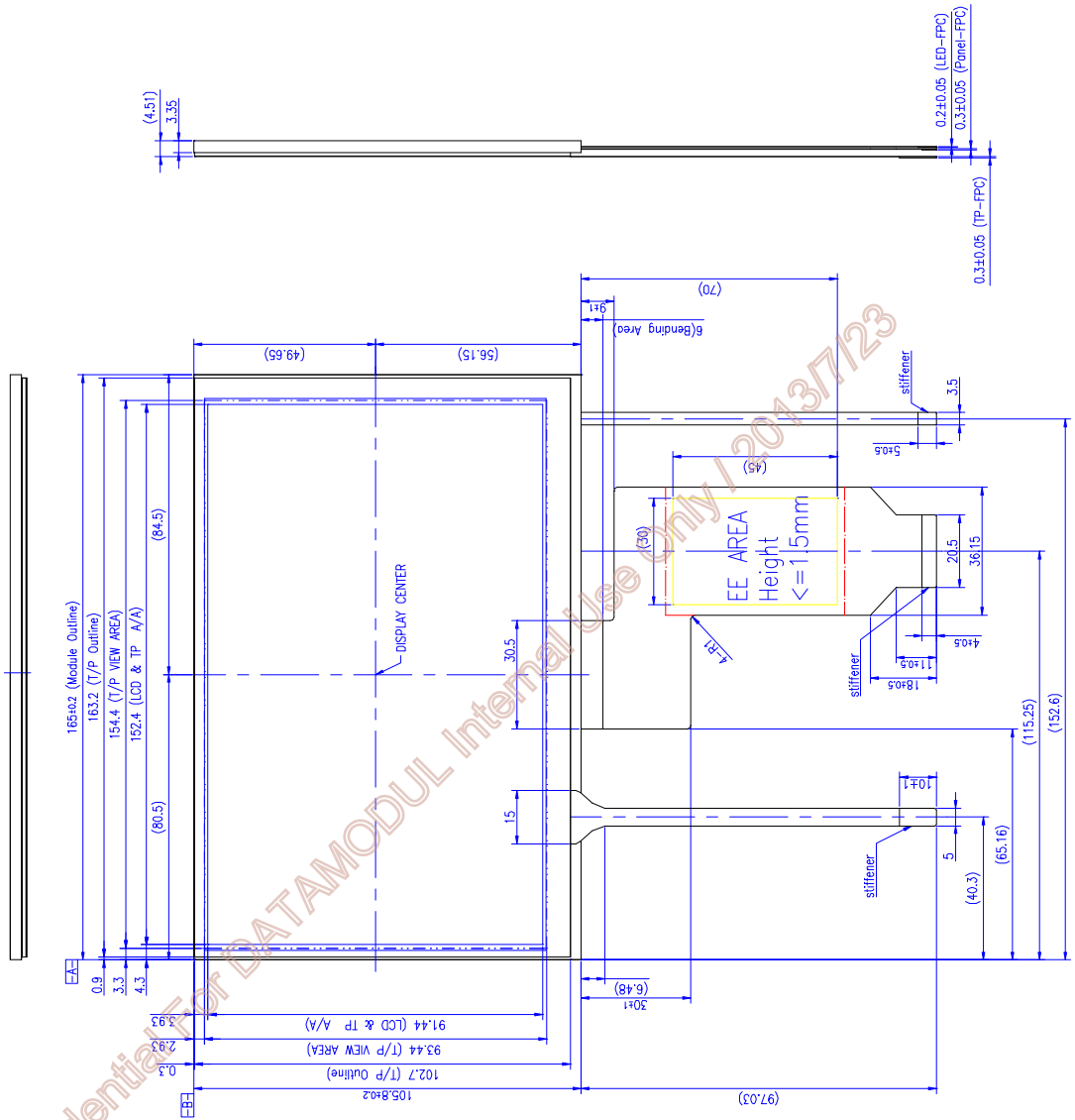

- NOTES:
- General tolerance ±0.3mm
 - The bending radius of FPC should be larger than 0.6mm
 - Unit:mm
 - * It means the case open should not be larger than this area .
 - ** Suggested gasket (cushion) area
 - *** The thickness of solder area .
 - The dimension in brackets () are for reference.
 - This Touch Panel is finger use only.

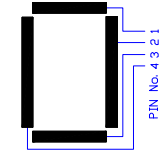
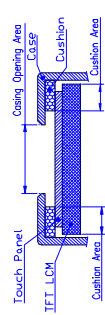

Pin No.	Description
1	X _L
2	Y _B
3	X _R
4	Y _U

X : Glass electrode
Y : Film electrode

AUO Confidential For DATAMODUL Internal Use Only / 2013/7/23

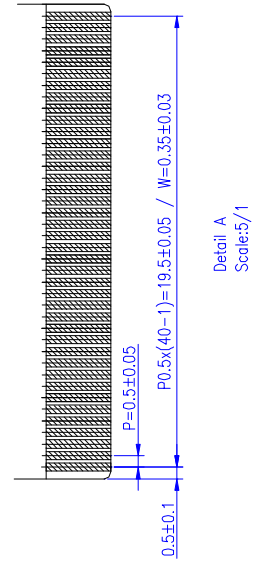
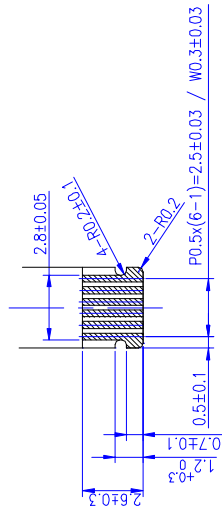
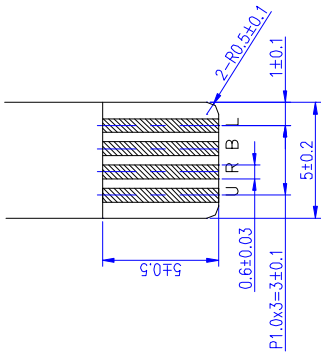
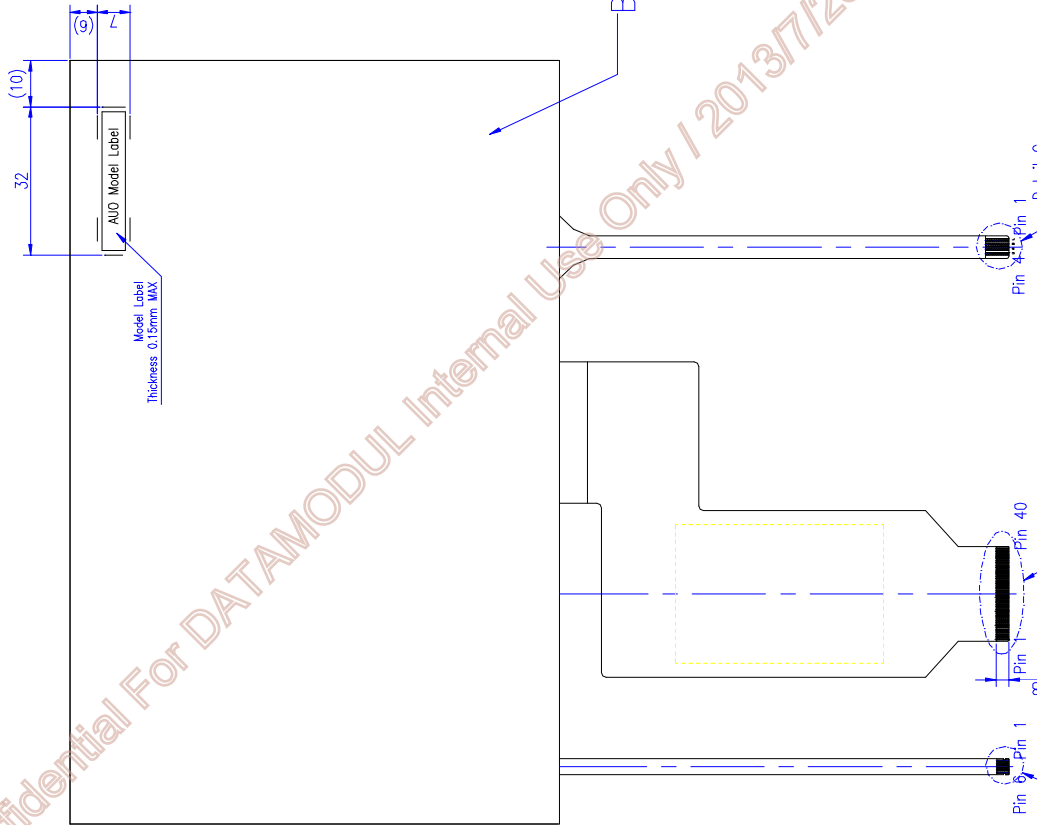

10. Label and Packaging

10.1 Shipping Label (on the rear side of TFT-LCD display)



10.2 Carton Package

Max capacity: 60 TFT-LCD module per carton

Max weight: 12.0 kg per carton

Outside dimension of carton: 608mm(L)*361mm(W)*226mm(H)

Pallet size: 1230 mm * 1110 mm * 135 mm

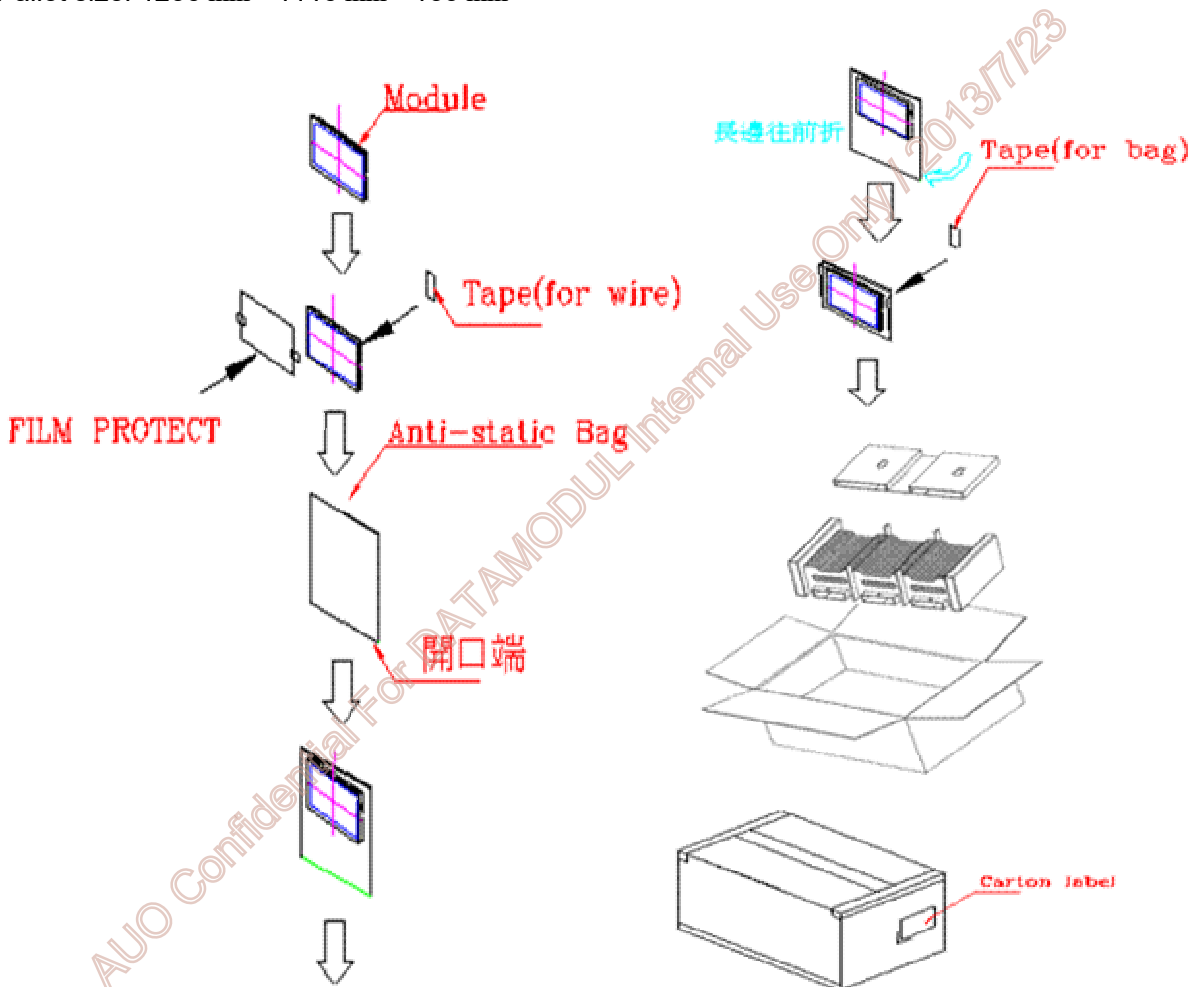

Box stacked_Max

Module by air : (2 *3) *5 layers , one pallet put 30 boxes , total 1800pcs module

Module by sea : (2 *3) *5 layers + (2 *3) *3 layers , two pallet put 48 boxes , total 2520pcs module

Module by sea_HQ : (2 *3) *5 layers+(2 *3) *4 layers, two pallet put 54 boxes, total 3240pcs module

11 Safety

11.1 Keen Edge Requirements

There will be no keen edges or corners on the display assembly that could cause injury.

11.2 Materials

11.2.1 Toxicity

There will be no carcinogenic materials used anywhere in the TFT-LCD module. If toxic materials are used, they will be reviewed and approved by the responsible AUO toxicologist.

11.2.2 Flammability

All components including electrical components that do not meet the flammability grade UL94-V1 in the TFT-LCD Module will complete the flammability rating exception approval process.

The printed circuit board will be made from material rated 94-V1 or better. The actual UL flammability rating will be printed on the printed circuit board.

11.3 Capacitors

If any polarized capacitors are used in the TFT-LCD module, provisions will be made to keep them from being inserted backwards.

11.4 National Test Lab Requirement

The TFT-LCD Module will satisfy all requirements for compliance to UL 60950 (U.S.A. Information Technology Equipment).

DATA MODUL

DISPLAYS AND EMBEDDED SOLUTIONS



DATA MODUL Headquarters Munich

Landsberger Str. 322
D-80687 Munich - Germany
Phone: +49-89-56017-0
Fax: +49-89-56017-119
www.data-modul.com

Sales Office Hamburg

Borsteler Chaussee 51
D-22453 Hamburg - Germany
Phone: +49-40-42947377-0

Sales Office Duesseldorf

Fritz-Vomfelde-Str. 8
D-40547 Duesseldorf - Germany
Phone: +49-211-52709-0

Sales Office Scandinavia

Lundsmindevej 5
DK-6000 Kolding - Denmark
Phone: +45-75-224477

DATA MODUL FRANCE

7 rue Saint Christophe
F-60300 BARON - FRANCE
Phone: +33-3-44549699

DATA MODUL Italy, S.r.l.

Regus Center Senigallia
Via Senigallia 18/2
I-20161 Milano - Italy
Phone: +39-02-64672509

DATA MODUL Iberia, S.L.

c/ Adolfo Pérez Esquivel 3
Edificio Las Americas III Oficina 40
28230 Parque Empresarial
Las Rozas / Madrid - Spain
Phone: +34-916-366458

DATA MODUL Suisse GmbH

Stationsstr. 57
CH-8606 Nänikon - Switzerland
Phone: +41-44-94091-50

DATA MODUL Ltd. / UK

Collins Building
3 Vigo Place - Aldridge - Walsall
WS9 8UG - United Kingdom
Phone: +44-1922-457358

DATA MODUL Inc. / USA

275 Marcus Blvd, Unit K
Hauppauge, NY 11788 - USA
Phone: +1-631-951-0800