

RoHS

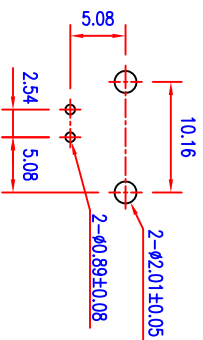

PC BOARD LAYOUT

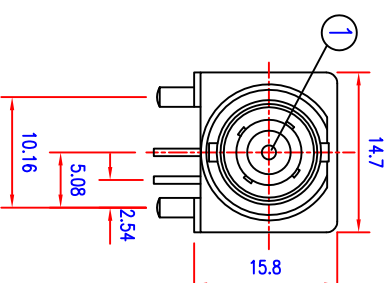
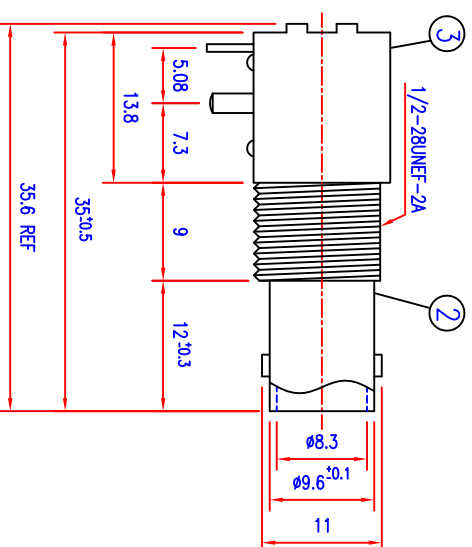
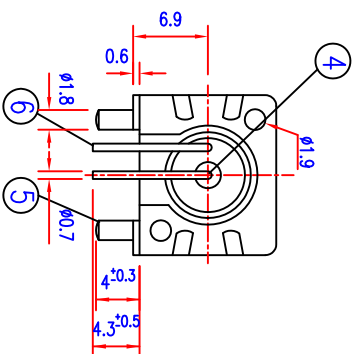

HOW TO ORDER

ITEM NO.	H	ohms
TL4258-15.8-50R+NW	15.8	50R

SPECIFICATION
 BNC CONNECTOR
 RIGHT ANGLE FEMALE PANEL MOUNT WITH NUT AND WASHER
 NICKEL PLATED H=15.8 , 50ohms
 BNC 母, 90° 腳, 鍍鍍, 附件全
 符合 RoHS 環保規格

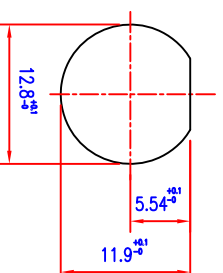
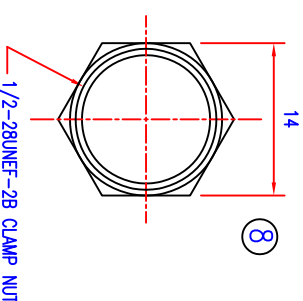
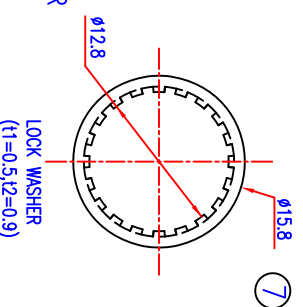

RECOMMENDED MOUNTING HOLE
 MAXIMUM PANEL THICKNESS : 5.5MM

UNLESS OTHERWISE SPECIFIED
GENERAL TOLERANCES
 0.5~6 = ±0.2
 >6~30 = ±0.4
 >30~120 = ±0.6

8	NUT	BRASS	NICKEL PLATING	
7	WASHER	STEEL	NICKEL PLATING	
6	SOLDER TAIL	COPPER WIRE	TIN PLATING	
5	MOUNTING POST	BRONZE	TIN PLATING	
4	INSULATOR	PE-606		
3	HOUSING	PBT	WHITE	
2	BODY	ZINC	ALLOY NICKEL PLATING	
1	CENTER CONTACT	BRONZE	GOLD PLATING	
NO.	DESCRIPTION	QTY	MATERIAL	SPECIFICATION
DRAW BY	CHUN	122309	SCALE	1 : 1.5
DEGN BY	YANG		UNIT	MM
APPD BY	RAY		PROJ	

同利企業有限公司

TELE LONG ENTERPRISE CO.,LTD

DATE	DRAWNG BY	REVISED

DWG NO.	TL4258-15.8-50R +NW-TPSS3-A1
TITLE	BNC CONNECTOR
ITEM NO.	TL4258-15.8-50R +NW
REMARK	