

FEATURES

1. Package Type: SIP8
2. Operating Temperature Range: -40°C - +105°C
3. Isolation Voltage: 1500VDC
4. 2:1 Wide Input Voltage Range
5. High efficiency up to 83%
6. With the output overcurrent, output short circuit protection mechanism
7. Fields of application: electric power, industrial control, communication, Internet of Things, automobile, rail transit, etc

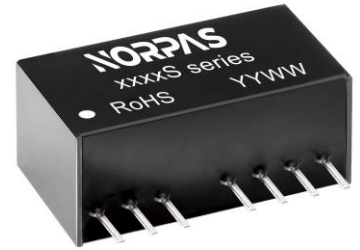

3 years
Warranty

Selection Guide

Part No.	Input Voltage (VDC)	Output			Ripple & Noise (Typ./Max.) (mVp-p)	Full Load Efficiency% (Min./Typ.)	Capacitive Load Max. (μF)	
	Nominal (Range)	Voltage (VDC)	Current Min.(mA)	Current Max.(mA)				
NKB0503S-3WR2	5 (4.5-9)	3.3	758	38	40/75	67/69	1800	
NKB0505S-3WR2		5	600	30		72/74	2200	
NKB0509S-3WR2		9	333	20		74/76	1000	
NKB0512S-3WR2		12	250	13		76/78	680	
NKB0515S-3WR2		15	200	10		73/75	470	
NKB0524S-3WR2		24	125	6		75/77	330	
NKA0505S-3WR2		±5	±300	±15		73/75	#1000	
NKA0509S-3WR2		±9	±167	±10		74/76	#680	
NKA0512S-3WR2		±12	±125	±6		76/78	#470	
NKA0515S-3WR2		±15	±100	±5		76/78	#330	
NKA0524S-3WR2		±24	±63	±3		75/77	#220	
NKB1203S-3WR2		12 (9-18)	3.3	758		38	70/100	74/76
NKB1205S-3WR2	5		600	30	75/77	2200		
NKB1206S-3WR2	6		500	25	77/79	1800		
NKB1209S-3WR2	9		333	17	77/79	1000		
NKB1212S-3WR2	12		250	13	100/150	81/83		680
NKB1215S-3WR2	15		200	10		82/84		471
NKB1224S-3WR2	24		125	6	40/75	80/82	330	
NKA1205S-3WR2	±5		±300	±15		77/79	#1000	
NKA1209S-3WR2	±9		±167	±8		77/79	#680	
NKA1212S-3WR2	±12		±125	±6		78/80	#470	
NKA1215S-3WR2	±15		±100	±5		79/80	#330	
NKB2403S-3WR2	24 (18-36)		3.3	758		38	73/75	2700
NKB2405S-3WR2		5	600	30	80/82	2200		
NKB2409S-3WR2		9	333	17	81/83	1000		
NKB2412S-3WR2		12	250	13	82/84	680		

NKB2415S-3WR2		15	200	10	100/150	82/84	470
NKB2424S-3WR2		24	125	6		82/84	330
NKA2405S-3WR2		±5	±300	±15	40/75	78/80	#1000
NKA2409S-3WR2		±9	±167	±8		79/81	#680
NKA2412S-3WR2		±12	±125	±6		81/83	#470
NKA2415S-3WR2		±15	±100	±5		81/83	#330
NKB4803S-3WR2		3.3	758	38		100/150	74/76
NKB4805S-3WR2		5	600	30	40/75	75/77	2200
NKB4812S-3WR2		12	250	13		79/81	680
NKB4815S-3WR2		15	200	10	40/75	83/85	470
NKB4824S-3WR2	24	125	6	70/100	81/83	330	
NKA4805S-3WR2	±5	±300	±15	100/150	78/80	#1000	
NKA4812S-3WR2	±12	±125	±6	40/75	81/83	#470	
NKA4815S-3WR2	±15	±100	±5		81/83	#330	

each output

Input Specifications

Item	Operating Conditions	Min.	Typ.	Max.	Unit	
Input Current (full load/no load)	5VDC Input	3.3VDC Output	--	735/40	758/85	mA
		Other Output	--	805/40	846/85	
	12VDC Input	3.3VDC Output	--	278/30	286/40	
		Other Output	--	314/30	338/40	
	24VDC Input	3.3VDC Output	--	140/20	145/40	
		Other Output	--	154/20	163/40	
48VDC Input	3.3VDC Output	--	69/5	72/15		
	Other Output	--	78/5	85/15		
Reflected Ripple Current	5VDC Input	--	20	--	VDC	
	12VDC Input	--	20	--		
	24VDC Input	--	55	--		
	48VDC Input	--	55	--		
Impulse Voltage	5VDC Input	-0.7	--	12	VDC	
	12VDC Input	-0.7	--	25		
	24VDC Input	-0.7	--	50		
	48VDC Input	-0.7	--	100		
Starting Voltage	5VDC Input	--	--	4.5	VDC	
	12VDC Input	--	--	9		
	24VDC Input	--	--	18		
	48VDC Input	--	--	36		
Input Filter		Capacitance Filter				
Hot Plug		Unavailable				
CTRL	Module off	0-0.7V turn off				
	Module on	No connect or 3.5-12V on				

Output Specifications

Item	Operating Conditions		Min.	Typ.	Max.	Unit
Output Voltage Accuracy	5% - 100% Load, Input voltage range		--	±1.0	±3.0	%
No-load Output Voltage Accuracy	Input Voltage Range	3VDC	--	±5.0	±8.0	
		Other	--	±1.5	±5.0	
Linear Regulation	Full load, Input voltage from low limit to high limit		--	±0.2	±0.5	
Load Regulation	5% - 100% Load		--	±0.6	±1.0	
Transient Recovery Time	25% load step change		--	0.5	3	ms
Transient Response Deviation			--	±2.5	±5	%
Temperature Coefficient	Full Load		--	±0.02	±0.03	%/°C
Over Current Protection			110	140	--	%Io
Short-circuit Protection			Continuous, Self-Recovery			

General Specifications

Item	Operating Conditions	Min.	Typ.	Max.	Unit
Insulation Voltage	Input-output, test time 1 minute, leakage current less than 1mA	1500	--	--	VDC
Insulation Resistance	Input-output, insulated voltage 500VDC	1000	--	--	MΩ
Isolation Capacitance	Input-output, 100KHz/0.1V	--	120	--	pF
Operating Temperature	Derating when operating temperature ≥ 85°C, (See Figure 1)	-40	--	85	°C
Storage Temperature		-55	--	105	
Storage Humidity	Non-condensing	--	--	95	%RH
Pin welding can withstand the highest temperature	Soldering spot is 1.5mm away from case for 10 seconds	--	--	300	°C
Switching Frequency	Full Load, Nominal Input Voltage	--	250	--	kHz
MTBF	MIL-HDBK-217F@25°C	>1000Kh			

Mechanical Specifications

Case Material	Black plastic; flame-retardant and heat-resistant (UL 94V-0 rated)
Package Dimensions	22.00 * 12.00 * 9.50 mm
Weight	3.8g(Typ.)
Cooling Method	Free air convection

EMC Specifications

EMI	CE	CISPR32/EN55032 CLASS B (The recommended circuit is shown in Figure 3-②)	
	RE	CISPR32/EN55032 CLASS B (The recommended circuit is shown in Figure 3-②)	
EMS	ESD	IEC/EN61000-4-2 Contact±4KV	perf.Criteria B
	RS	IEC/EN61000-4-3 10V/m	Perf.Criteria A
	EFT	IEC/EN61000-4-4 ±2KV(The recommended circuit is shown in Figure 3-①)	Perf.Criteria B
	Surge	IEC/EN61000-4-5 line to line±2KV (The recommended circuit is shown in Figure 3-①)	Perf.Criteria B
	Cs	IEC/EN61000-4-6 3 Vr.m.s	Perf.Criteria A

Typical Characteristic Curves

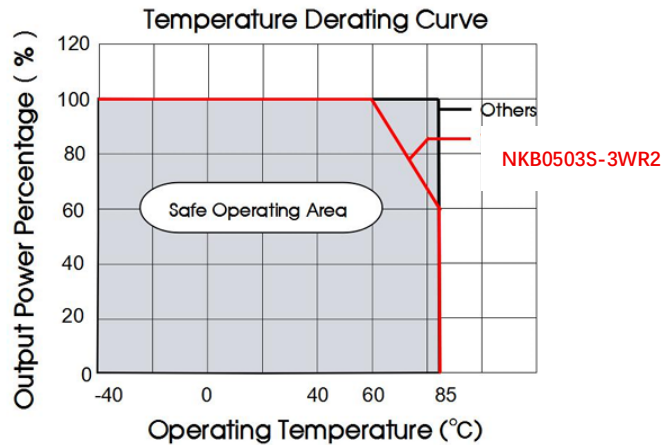
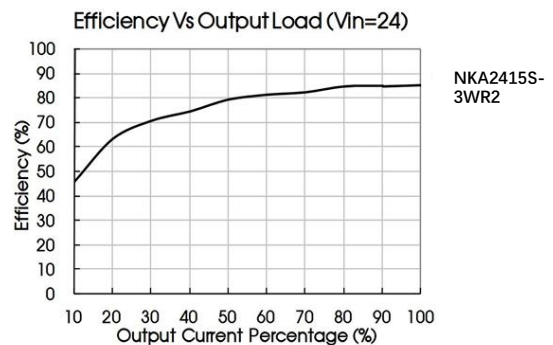
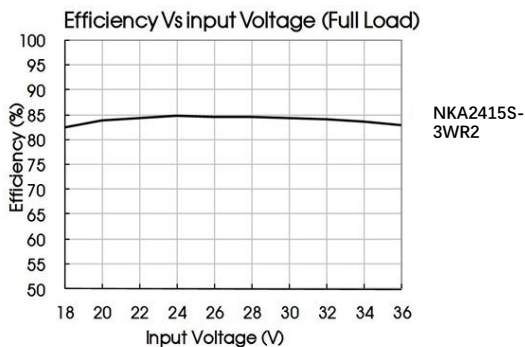
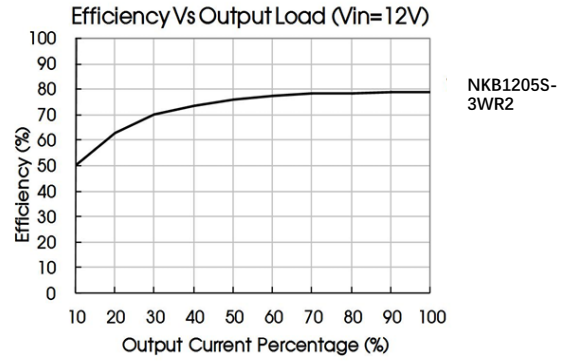
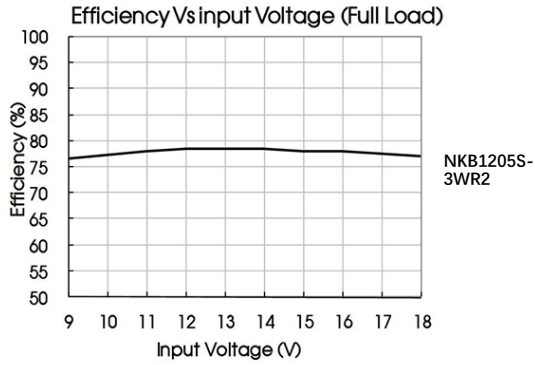

Fig 1





Circuit Design and Application

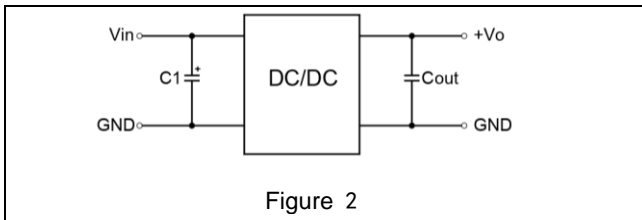

Figure 2

Recommended Capacitive Load Value Table	
Cin(μF)	Cout(μF)
100	22

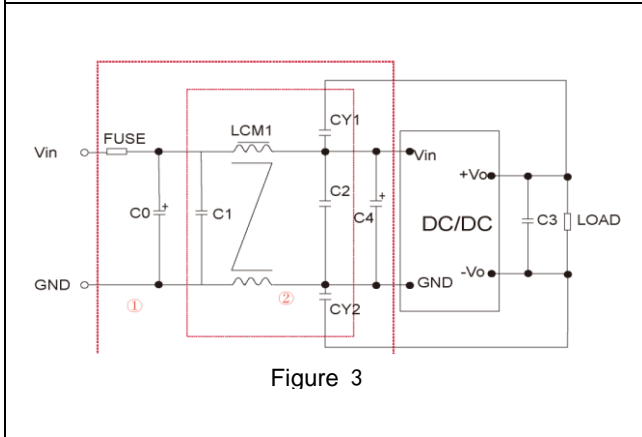

Figure 3

EMI Recommended Parameter Table		
Model	Vin:12V	Vin:24V
FUSE	Select according to the actual input current of the customer	
C0、C4	330uF/35V	330uF/50V
C1、C2	10μF/50V	
LCM1	1.4-1.7mH	
C3	22μF/50V	
CY1、CY2	1nF/400VAC	

Note: Part 1 in Figure 3 is for EMC testing; The second part is used for EMI filtering, which can be selected according to the demand.

Dimensions and Recommended Layout

Dimensions

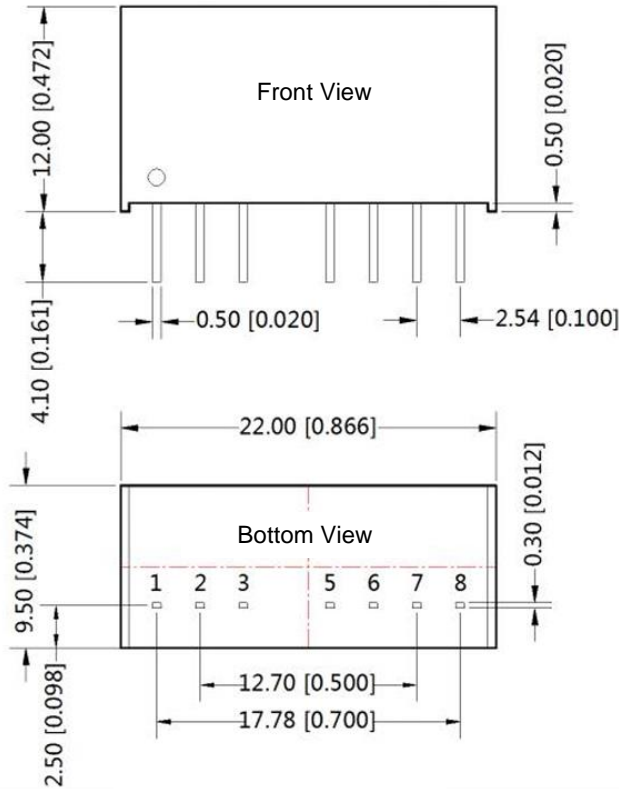

PCB Printing Layout & Pin Definition Table

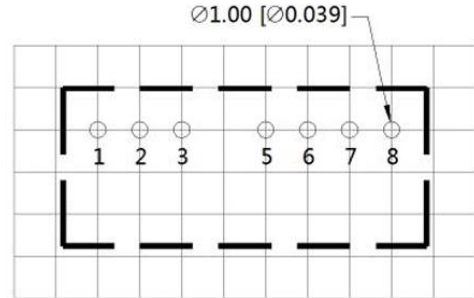

Note: The grid distance is 2.54mm*2.54mm

Pin	Function (single)	Function (double)
1	GND	GND
2	Vin	Vin
3	CTRL	CTRL
5	NC	NC
6	+Vo	+Vo
7	0V	0V
8	CS	-Vo

NC: Cannot be connected to any electrical connection

Note:

Unit: mm[inch]

Pin section tolerances: $\pm 0.10 [\pm 0.004]$

General tolerances: $\pm 0.50 [\pm 0.020]$

Note:

1. If the product works under the minimum required load, it cannot guarantee that the performance of the product complies with all the performance indicators in this manual;
2. The maximum capacitive load is tested under the input voltage range and full load condition;
3. Unless otherwise stated, all indexes in this manual are measured at $T_a=25^\circ\text{C}$, humidity $<75\%\text{RH}$, nominal input voltage and rated output load;
4. All index testing methods in this manual are based on the enterprise standards of the company;
5. Our company can provide product customization, specific needs can directly contact our technical staff;

NORPAS-POWER TECHNOLOGY CO., LTD.

www.norpas-power.com Mail: info@norpas-power.com

Specifications can be changed without notice! Make sure you are using the latest documentation, downloadable at www.norpas-power.com

REV:07/2024