

# Specification

## 规格书

Shineon P/N : 7070A06-XXX750-2S10P-PHMA1-LX  
易美产品型号:

Document number : **NCYM-DS-RD**  
文件编号:

Customer :  
客户名称

Customer P/N :  
客户产品型号

### Customer Approved Production Parameter BIN

客户承认产品BIN表

<b>IV/LM:</b> 亮度/流明:	<b>WL/XY:</b> 波长/区块:	<b>CCT:</b> 色温:
<b>VF:</b> 电压:	<b>Ra:</b> 显指:	<b>Other:</b> 其它:
<b>Approved By</b> 审核		<b>Checked By</b> 确认

### Shineon Checked

易美审核

<b>Approval</b> 核准	<b>Check</b> 审核	<b>Design</b> 设计
朱磊	朱磊	王磊

## Features 特性

- Dimensions: 7x7x0.7mm. 封装尺寸: 7x7x0.7mm
- Wide viewing angle. 广视角
- ROHS Compliant. ROHS认证
- PCT package . PCT封装



### ATTENTION

OBSERVE PRECAUTIONS  
FOR HANDLING  
ELECTROSTATIC  
DISCHARGE  
SENSITIVE  
DEVICES

注意：接触静电放电敏感元件时请采取适当的预防措施

## Applications 应用

- Outdoor lighting : LED Downlight, Flood Light, Street light Highbay  
户外照明：筒灯、投光灯、路灯、高棚灯



## Package Dimensions 封装尺寸

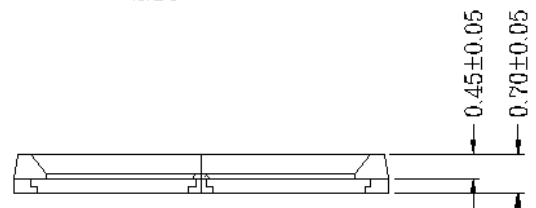
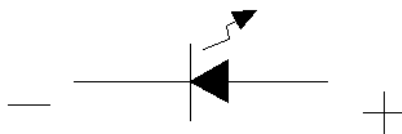
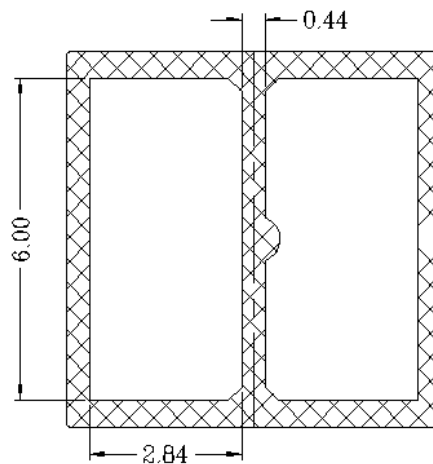
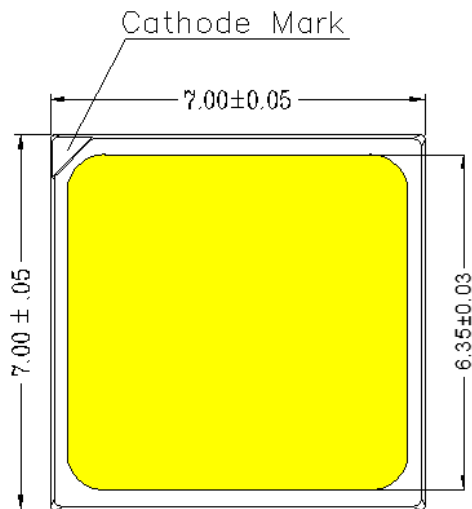

### Notes:

1. All dimensions in millimeters. 所有尺寸单位为mm
2. Thickness tolerance of copper plate is  $\pm 0.02$ mm. 铜材料片厚度公差为 $\pm 0.02$ mm
3. Thickness tolerance of product is  $\pm 0.05$ mm. 产品厚度公差为 $\pm 0.05$ mm
4. Tolerance is  $\pm 0.1$ mm unless otherwise noted. 如未特别注明，默认公差为 $\pm 0.1$ mm
5. Specifications are subject to change without notice. 规格如有变更，恕不另行通知。

### Absolute Maximum Ratings at Ts=25°C 最大限定参数

Parameter 参数	Symbol 符号	Value 值	Units 单位
Forward Current 正向电流	IF	1000	mA
Peak Forward Current 正向脉冲电流	IFP	1200	mA
Power Dissipation 功耗	PD	6000	mW
Electrostatic Discharge 静电击穿电压	ESD	2000HBM	V
Storage Temperature 储存温度	Tstg	-40~+100	°C
Operating Temperature 操作温度	TOPR	-40 ~ +85	°C
Soldering Temperature 焊接温度	T <sub>slid</sub>	Reflow Soldering: 260°C for 10 seconds	Soldering Temperature 焊接温度
Junction Temperature 结温	TJ	120	°C

### Electrical/Optical Characteristics at Ts=25°C 电性与光学特性

Item 项目	Symbol 符号	Testcondition 测试条件	Value			Unit 单位
			Min. 最小值	Typ 典型值	Max. 最大值	
Forward Voltage 正向电压	VF	IF=750mA	5.6	---	6.0	V
Reverse Current 漏电流	IR	VR=5V	---	---	1	uA
Luminous Flux 光通量	Φ	IF=750mA	650	---	1050	Lm
Color Rendering Index 显色指数	CRI	IF=750mA	69	---	---	--
Color Temperature 色温	CCT	IF=750mA	2600	---	7000	K
Viewing Angle 发光角度	2θ1/2	IF=750mA	---	120	---	deg
Thermal Resistance. (热阻)	RTHJ-S	IF=750mA	---	2	---	°C/W

#### Notes 注:

- Luminous flux is measured with an accuracy of  $\pm 5\%$ . 光通量的测量精度为  $\pm 5\%$ 。
- The above forward voltage measurement allowance tolerance is  $\pm 1V$ . 以上所示电压测量误差  $\pm 1V$ 。
- CRI is measured with an accuracy of  $\pm 2$ . 显色指数测量精度为  $\pm 2$ 。
- All measurements were made under the standardized environment of Shineon. 所有测试都是基于易美现有的标准测试平台
- Care is to betaken that power dissipation does not exceed the absolute maximum rating of the product. 使用功率不能超过规定的最大值。
- When the LEDs are in operation the maximum current should be decided after measuring the package temperature , junction temperature should not exceed the maximum rate. LED使用的最大电流需要根据散热条件确定, 结温不能超过最大值。
- ESD yield is over 90% at 2000V ESD (HBM). ESD protection during products handing is needed.  
90%的LED通过人体模式ESD2000V 测试, 在操作时请注意静电防护。

**7070 A 06-XX N 750-U 2S10P- XX**

①      ②      ③      ④      ⑤      ⑥      ⑦      ⑧      ⑨

①	机种型号XXXX Model	2835; 3014; 3020; 4014; 5630; 3030; 2016; 3535; 5050; 7070; 1F1F
②	LM-80报告X LM-80report	A:通用报告General report    B: 独立报告    Independent report
③	电压类别XX Forward voltage	03:3V; 06:6V; 09:9V; 12:12V; 18:18V; 36:36V; .....
④	中心色温XX CCT code	27: 2700K; 30: 3000K ; 35:3500K; 57:5700K.....
⑤	显指代码X Ra code	L: 60—70; N: 70—80; H: 80—90; V: 85-95; S: 90—100; E: 95—100; F: 96-100
⑥	电流代码XX Forward current	100: 100mA; 300: 300mA ; 350 : 350mA; 750: 750mA.....
⑦	金线代码X Wire type	No code : 合金线 Alloy wire; K: K金线 Gold alloy; U: 纯金线 gold wire; .....
⑧	芯片数量XX Chip Qty'	1S: 单晶 single; 2S: 双晶串联 Double series connection; 3S: 三晶串联 Triple series connection; 2P: 双晶并联 Double parallel connection; 2S4P:双串四并 Double series and four parallel.....
⑨	方案代码XX Internal code1	.....

**Luminous Flux 光通量 (Tj=25°C)**

PRODUCT 产品	IF 正向电流	CCT 色温	Ra 显色指数	IV code 亮度代码		Luminous Flux 光通量		Unit 单位
7070A06-27X750-2S10P-PHMA1-LX	750mA	2700K	70	X4	Y0	850-900	900-950	LM
			80	X1	Y0	800-850	850-900	
			90	W0	W3	700-750	750-800	
7070A06-30X750-2S10P-PHMA1-LX	750mA	3000K	70	Y0	Y1	900-950	950-1000	LM
			80	X4	Y0	850-900	900-950	
			90	W3	X1	750-800	800-850	
7070A06-35X750-2S10P-PHMA1-LX	750mA	3500K	70	Y0	Y1	900-950	950-1000	LM
			80	X4	Y0	850-900	900-950	
			90	W3	X1	750-800	800-850	
7070A06-40X750-2S10P-PHMA1-LX	750mA	4000K	70	Y1	Y3	950-1000	1000-1050	LM
			80	Y0	Y1	900-950	950-1000	
			90	X1	X4	800-850	850-900	
7070A06-50X750-2S10P-PHMA1-LX	750mA	5000K	70	Y1	Y3	950-1000	1000-1050	LM
			80	Y0	Y1	900-950	950-1000	
			90	X1	X4	800-850	850-900	
7070A06-57X750-2S10P-PHMA1-LX	750mA	5700K	70	Y1	Y3	950-1000	1000-1050	LM
			80	Y0	Y1	900-950	950-1000	
			90	X1	X4	800-850	850-900	
7070A06-65X750-2S10P-PHMA1-LX	750mA	6500K	70	Y1	Y3	950-1000	1000-1050	LM
			80	Y0	Y1	900-950	950-1000	
			90	X1	X4	800-850	850-900	

**Forward Voltage 正向电压(Tj=25°C)**

Part Number 品名	Condition 条件	Rank 等级代码	Forward Voltage 正向电压	Unit 单位
7070A06-XXX750-2S10P-PHMA1-LX	750mA	C8	5.6-5.8	V
		C9	5.8-6.0	V

## Color Bin Definitions 色坐标

Bin Code 等级代码	Center Point		MAJOR AXIS (a ,b).		Theta。
	x	y	3-Step	5-Step	
2700	0.4655	0.4285	(0.0081, 0.0042)	(0.0135, 0.007)	53.7
3000	0.4391	0.4214	(0.00834, 0.00408)	(0.0139, 0.0068)	53.22
4000	0.3903	0.405	(0.00939, 0.00402)	(0.01565, 0.0067)	53.22
5000	0.3459	0.3761	(0.00822, 0.00354)	(0.0137, 0.0059)	59.62
5700	0.3298	0.3585	(0.00746, 0.0032)	(0.01243, 0.00533)	59.09
6500	0.3205	0.3503	(0.00669, 0.00285)	(0.01115, 0.00475)	58.57

### Notes 注:

1.The above color coordinates measurement allowance tolerance is 0.005.以上所示坐标测量误差 0.005。

2.Some color and CRI bins may have limited availability, please contact us before ordering.部分颜色和显指可能有限制，请在订购前与我们联系。

Typical optical characteristics curves 典型光学特性曲线

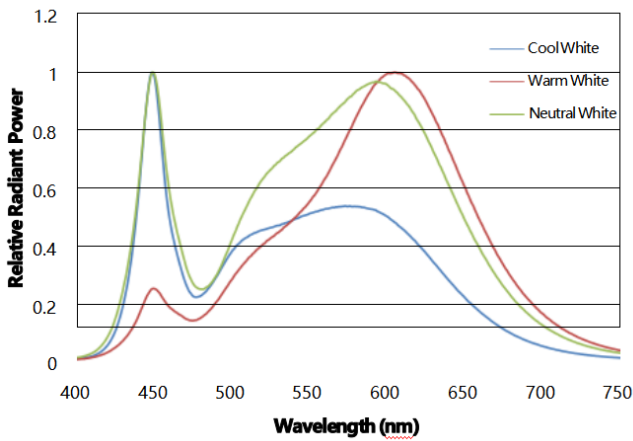

Typical spectral distribution  
典型光谱分布

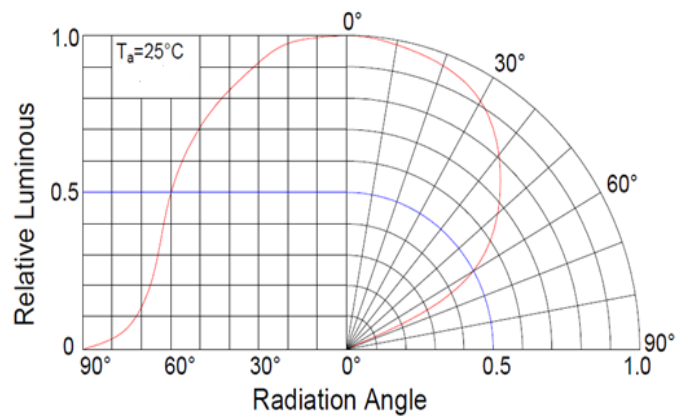

Typical Light-Emitting Angle Radiation Pattern  
典型发光角度辐射图

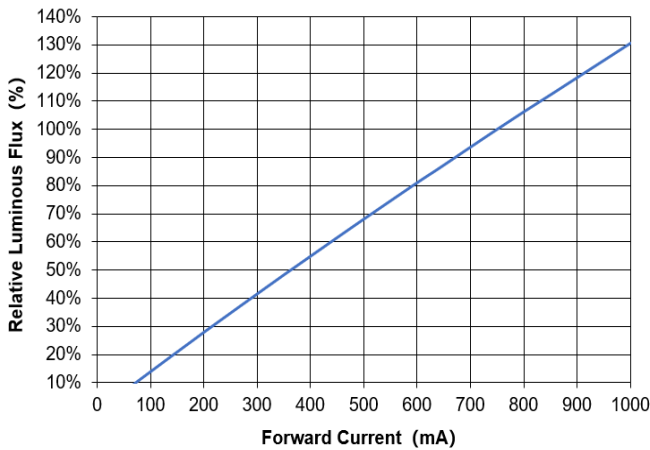

Forward Current Vs. Relative Intensity  
正向电流与相对光强特性曲线

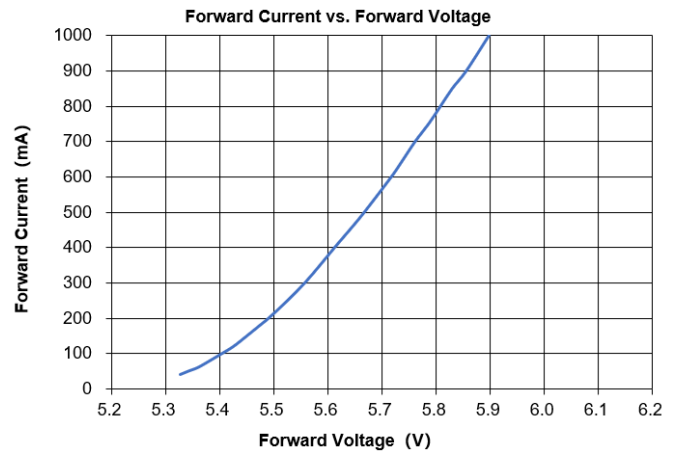

Forward Voltage Vs. Forward Current  
伏安特性曲线

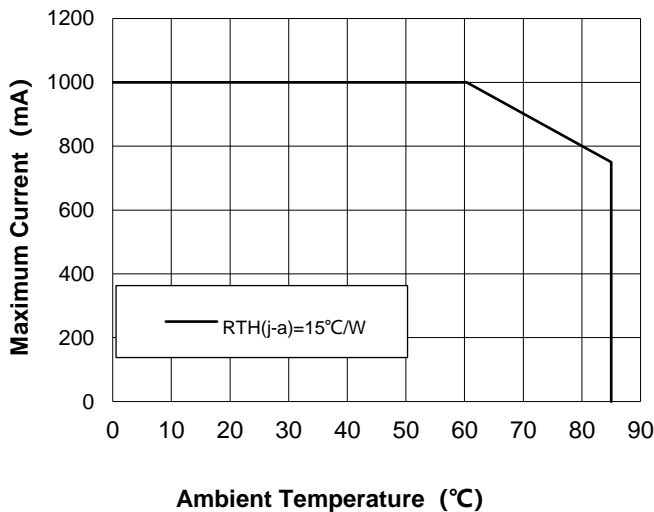

Forward Current VS Soldering Temperature  
电流VS温度特性曲线

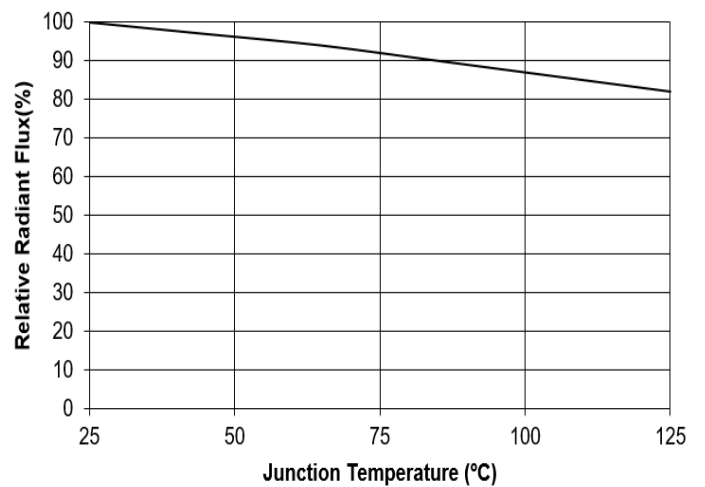

Solder Temperature Vs Relative Intensity  
温度与相对光强特性曲线

Performance at Commonly Used Drive Currents at Tj=25°C 5700K Ra70

Forward Current Typ IF (mA)	Forward Voltage Typ VF (V)	Power Typ P (W)	Luminous Flux Typ ΦV (lm)	Luminous efficacy Typ η (lm/W)
50	5.34	0.27	67	251
100	5.40	0.54	135	250
150	5.45	0.82	204	248
200	5.49	1.10	271	246
250	5.53	1.38	336	243
300	5.56	1.67	402	241
350	5.59	1.95	467	239
400	5.61	2.24	531	237
450	5.64	2.54	596	235
500	5.67	2.83	659	233
600	5.72	3.43	784	229
700	5.76	4.03	906	225
750	5.79	4.34	967	223
800	5.81	4.64	1027	221
900	5.86	5.27	1145	218
1000	5.90	5.90	1263	215

## Packaging Specifications 包装规格

### Carrier Tape Dimensions 载带尺寸

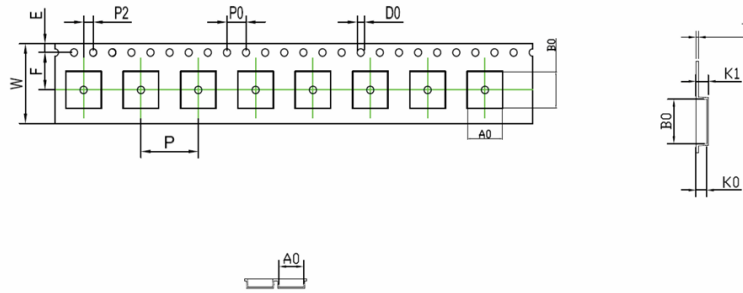

symbol	AO	BO	KO	PO	P	P2	长度/盘
Spec	7.30±0.1	7.30±0.1	1.00±0.1	4.00±0.10	12.0±0.1	2.00±0.10	200M/R
symbol	W	T	E	F	DO	D1	K1
Spec	16.0±0.3	0.30±0.05	1.75±0.10	7.5±0.1	1.50 <sup>+0.1</sup> <sub>0</sub>	1.50±0.10	1.20±0.1

### Reel Dimension 卷盘尺寸

#### Small reel 小卷

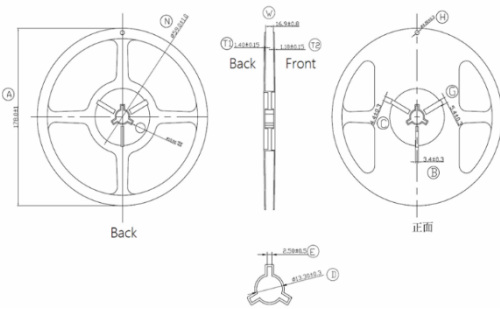

#### Big reel 大卷

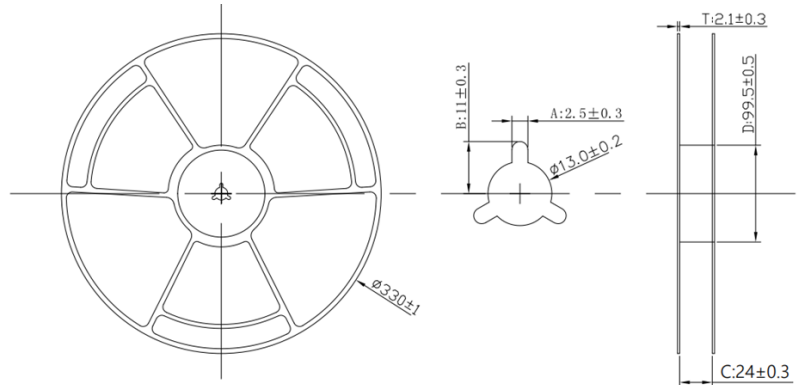

#### Notes注:

The tolerances unless mentioned  $\pm 0.2$ mm. Unit : mm  
 未注公差为 $\pm 0.2$ 毫米，尺寸单位：毫米  
 包装数量：500pcs/卷 or 2500pcs/卷

### Label Form Specification 标签规格

示例

Name: XXXXXXX-XXXX-XX-XXX-XX		
PrdName: [Barcode]		
Lot NO: XXXXXXTSXXXXXX-XX-X		
LotNo: [Barcode]		
BinCode: XXXXXXX		
BinCode: [Barcode]		
IF: XXXmA	Prd No: XXXXXXXXXX	
VF: XX-XXV	[Barcode]	
IV: XX-XXlm	Quantity: XXXXPCS	
Ra: >XX	[Barcode]	
CCT: XXXXK	[Barcode]	

Name: 7070A06-XXN750-2S10P-PHMA1-LX (XX代表色温)	
Lot NO: 工单号	
Bin Code: 亮度等级+色温代码+电压等级+显指 (例: L2/A50-3/C9/N)	
IF: XXX mA 测试电流	
VF: X.X-X.X V 电压范围	Prd No: 产品料号
IV:XX-XX lm 亮度范围	
Ra: >XX 显色指数	Quantity: 数量PCS
CCT:XXXXK 色温 (例5000K)	

## Moisture Resistant Packing Process 防潮包装过程

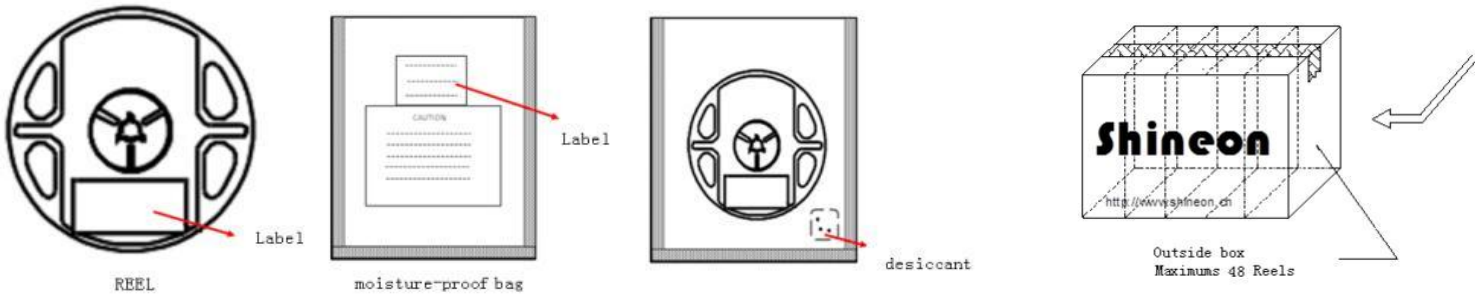

### Notes注:

Package : P/N、 Manufacturing data Code No. and quantity to be indicated on a damp proof Package. 包装 : 品名、生产数据代码和数量须在防潮包装上注明

## Reliability Test Items And Conditions 信赖性测试项目及条件

Test Items 项目	Test Condition 测试条件	Time 时间	Quantity 数量	Ac/Re 接收/拒收
Reflow 回流焊	Temp:260°Cmax T=10 sec	2times.	20Pcs	0/1
Thermal Shock 冷热冲击	-44°C 15min ↑↓10s 125°C 15min	100 cycle	20Pcs	0/1
High Temperature Storage 高温保存	Temp:100. °C	1000Hrs.	20Pcs	0/1
Low Temperature Storage 低温保存	Temp:-40°C	1000Hrs.	20Pcs	0/1
High Temperature High Humidity Life Test 高温高湿通电	60°C/ 90%RH IF=750mA	500Hrs.	20Pcs	0/1
Temperature Humidity Storage 高温高湿储存	TA=85°C RH=85%	500Hrs.	20Pcs	0/1
Steady State Operating Life of High Temperature 高温点亮稳态老化	Ts=85°C, IF=Max	1000Hrs.	20Pcs	0/1
Steady State Operating Life of Low Temperature 低温点亮稳态老化	Ta=-40°C, IF=Max	1000Hrs.	20Pcs	0/1
Solder Ability (SA) 可焊性	245°C5sec, 95%	5sec	11Pcs	0/1
Life Test 常温通电	TA=25°C, IF=750mA	1000Hrs.	10Pcs.	0/1

## Criteria For Judging Damage 失效判定标准

Test Items 项目	Symbol 符号	Test Condition 测试条件	Criteria For Judgement 判定标准	
			Min. 最小	Max. 最大
Forward Voltage 正向电压	VF	IF=750mA	-	U.S.L*)x1.1
Reverse Current 反向电流	IR	VR =7V	-	U.S.L*)x2.0
Luminous Flux 光通量	LM	IF=750mA	L.S.L*)x0.7	-
CCX&CCY X坐标&Y坐标	x,y	IF=Typical Current 典型电流		Shift<0.02 漂移<0.02

### Notes注:

- 1.U.S.L: Upper standard level规格上限, L.S.L: Lower standard level 规格下限
- 2.The Reliability tests are based on Shineon existing test platform. 信赖性测试基于易美现有的测试平台。
- 3.The technical information shown in the data sheets are limited to the typical characteristics and circuit examples of the referenced products. It does not constitute the warranting of industrial property nor the granting of any license.  
以上技术数据仅为产品的典型值, 只作为参考, 不作为任何应用条件及应用方式的保证。

## SMT Reflow Soldering Instructions SMT回流焊说明

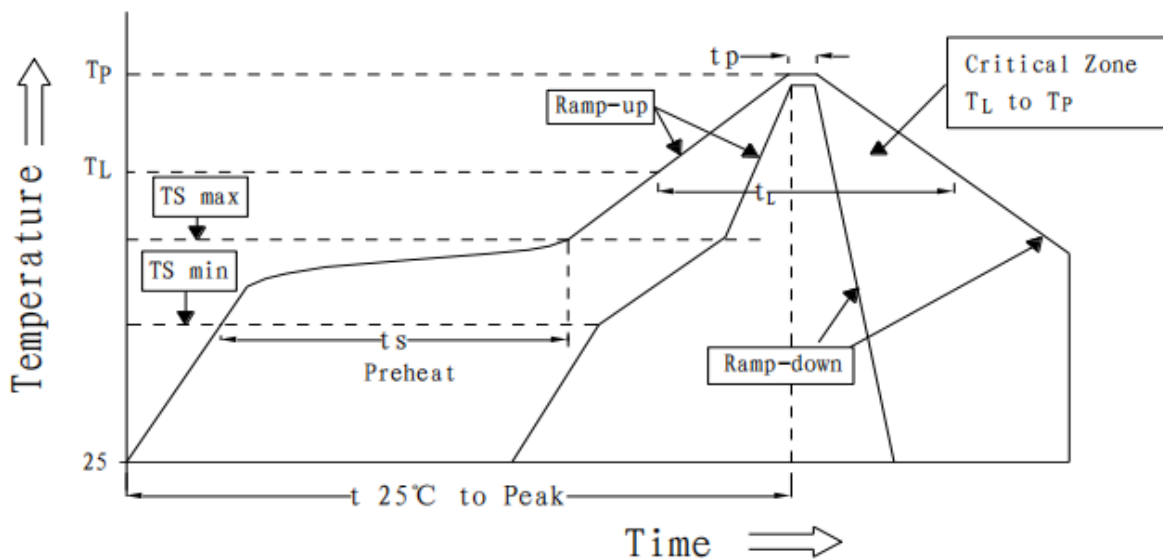

平均升温速度 (T <sub>max</sub> 至 T <sub>p</sub> )	最高 3 °C/ 秒
预热: 最低温度 (T <sub>min</sub> )	150 °C
预热: 最高温度 (T <sub>max</sub> )	200 °C
预热: 时间 (T <sub>min</sub> 至 T <sub>max</sub> )	60 - 120 秒
限时维持高温: 温度 (TL)	217 °C
限时维持高温: 时间 (tL)	最多60 秒
峰值 / 分类温度 (T <sub>p</sub> )	260 °C
限时峰值分类温度: 时间 (tp)	最多10 秒
与实际峰值温度 (T <sub>p</sub> ) 相差 5 °C 以内的保持时间	最多30 秒
降温速度	最高 6 °C/ 秒
25 °C 升至峰值温度所需时间	最多 8 分钟

Notes 注:

- 1.Reflow soldering should not be done more than two times. In the case of more than 24 hours passed soldering after first, LEDs will be damaged. 回流焊次数不可以超过两次，两次回流焊的时间间隔如果超过24小时，LED可能由于吸湿而损坏。
- 2.When soldering,do not put stress on the LEDs during heating.当焊接时，不要在材料受热时用力压胶体表面。

### Soldering Iron 烙铁焊接

- (1) When hand soldering, keep the temperature of iron below less 300°C less than 3 seconds  
当手工焊接时，烙铁的温度必须小于 300°C，时间不可超过 3 秒。
- (2) The handsolder should be done only one time.手工焊接只可焊接一次。

### Repairing 修补

Repair should not be done after the LEDs have been soldered. When repairing is unavoidable,a double-head soldering iron should be used (as below figure). It should be confirmed in advance whether the characteristics of LEDs will or will not be damaged by repairing. LED 回流焊后不应该修复，当必须修复时，必须使用双头烙铁，而且事先应确认此种方式会不会损坏 LED 本身的特性。

### Handling Precautions 使用注意事项

- (1) The encapsulated material of the LEDs is silicone. Therefore the LEDs have a soft surface on the top of package. The pressure to the top surface will be influence to the reliability of the LEDs. Precautions should be taken to avoid the strong pressure on the encapsulated part. So when use the picking up nozzle, the pressure on the silicone resin should be proper. LED 封装胶为硅胶，表面较软，用力按压胶体表面会影响 LED 可靠性，因此应有预防措施避免在按压器件，当使用吸嘴时，胶体表面的压力应是恰当的。

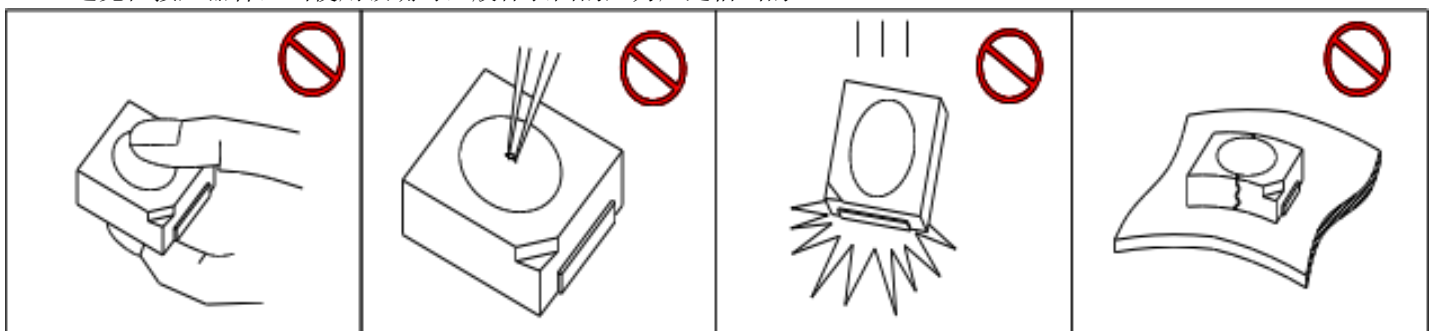

- (2) Components should not be mounted on warped (non coplanar) portion of PCB. After soldering, do not warp the circuit board. LED 灯珠不要焊接在弯曲的 PCB 板上，焊接之后，也不要弯折线路板。
- (3) Do not apply mechanical force or excess vibration during the cooling process to normal temperature after soldering. Do not rapidly cool device after soldering. 回流焊之后冷却过程中，不要对材料施加外力，也不要震动，回流焊后，不要采用激剧冷却的方式。
- (4) LED operating environment and sulfur element composition cannot be over 100PPM in the LED mating usage material. This is provided for informational purposes only and is not a warranty or endorsement. LED 工作环境及与 LED 适配的材料中硫元素及化合物成份不可超过 100PPM，这只是一个建议，不作任何品质担保。
- (5) In order to prevent external material from getting into the inside of LED, which may cause the malfunction of LED, the single content of Bromine element is required to be less than 900PPM, the single content of Chlorine element is required to be less than 900PPM, the total content of Bromine element and Chlorine element in the external materials of the application products is required to be less than 1500PPM. This is provided for informational purposes only and is not a warranty or endorsement. 为了防止外界物质进入 LED 内部以造成 LED 的损伤，所处环境及所用套件等等，单一的溴元素含量要求小于 900PPM，单一氯元素含量要求小于 900PPM，溴元素与氯元素总含量必须小于 1500PPM，这只是一个建议，不作任何品质担保。
- (6) VOCs (Volatile organic compounds) emitted from materials used in the construction of fixtures can penetrate silicone encapsulants of LEDs and discolor when exposed to heat and photonic energy. The result can be a significant loss of light output from the fixture. Knowledge of the properties of the materials selected to be used in the construction of fixtures can help prevent these issues. Shineon advises against the use of any chemicals or materials that have been found or are suspected to have an adverse affect on device performance or reliability. To verify compatibility, Shineon recommends that all chemicals and materials be tested in the specific application and environment for which they are intended to be used. Attaching LEDs, do not use adhesives that outgas organic vapor. 应用套件中的挥发性物质会渗透到 LED 内部，在通电产生光子及热的条件下，会导致 LED 变色，进而造成严重光衰，提前了解套件材料能够避免产生这些问题。易美反对使用任何对 LED 器件的性能或者可靠性有害的物质或材料，不管这些材料是已经证实了的还是仅仅怀疑有害。针对特定的用途和使用环境，易美建议对所有的物质和材料进行相容性的测试。在贴装 LED 时候，不要使用能产生有机挥发性气体的粘结剂。
- (7) In designing a circuit, the current through each LED must not exceed the absolute maximum rating specified for each LED. In the meanwhile, resistors for protection should be applied, otherwise slight voltage shift will cause big current change, burn out may happen. The driving circuit must be designed to allow forward voltage only when it is ON or OFF. If the reverse voltage is applied to LED, migration can be generated resulting in LED damage. 设计电路时，通过 LED 的电流不能超过规定的最大值，同时，还需使用保护电阻，否则，微小的电压变化将会引起较大电流变化，可能导致产品损毁。电路设计必须保证只有在开启或者关闭的时候出现正向电压的变化，不要施加反压，否则会损坏 LED。
- (8) Thermal Design is paramount importance because heat generation may result in the Characteristics decline, such as brightness decreased, Color change and so on. Please consider the heat generation of the LEDs when making the system design. LED 容易因为自身的发热和环境的温度改变而改变，温度升高会降低 LED 发光效率，影响发光颜色，所以在设计时应充分考虑散热问题。
- (9) Compared to standard encapsulants, silicone is generally softer, and the surface is more likely to attract dust, requiring special care during processing. In cases where a minimal level of dirt and dust particles cannot be guaranteed, a suitable cleaning solution must be applied to the surface after the soldering of components. Refond suggests using isopropyl alcohol for cleaning. In case other solvents are used, it must be assured that these solvents do not dissolve the package or resin. Ultrasonic cleaning is not recommended. Ultrasonic cleaning may cause damage to the LED. 与其他封装胶相比，硅胶通常较软，表面易吸附脏物，应用时应特别注意，当对产品洁净度要求较高时，回流焊以后需要采用恰当的清洗方式，我们推荐用异丙醇作清洗剂，如需要用到其他清洗剂，必须保证不会破坏封装体，超声清洗可能会对 LED 带来损害，不推荐这种清洗方式。

Storage 储存

Conditions 种类		Temperature 温度	Humidity 湿度	Time 时间
Storage 储存	Before Opening Aluminum Bag 拆包前	≤30°C	≤75%	Within 1 Year From Date 一年内
	After Opening Aluminum Bag 拆包后	≤30°C	≤60%	24hours 24小时
Baking 烘烤		60 ±5°C	-	≥24hours 大于24小时

- (10) If the moisture absorbent material (silica gel) has faded away or the LEDs have exceeded the storage time baking treatment should be performed after unpacking and based on the following condition (65±5) °C for above 24 hours. 如果干燥剂或包装失效，或者产品不符合以上有效储存条件，需拆包后进行烘烤，烘烤条件：60±5°C，大于24小时。
- (11) If the package is flatulence or damaged, please notify the sales staff to assist. 如果包装胀气或者破损，请通知销售人员协助处理。
- (12) Similar to most Solid state devices; LEDs are sensitive to Electro-Static Discharge (ESD) and Electrical Over Stress (EOS). 像其他的半导体电子器件一样，LED对静电过流击穿非常敏感，需要做好防护。
- (13) Other points for attention, please refer to our relevant information. 其它注意事项请参照易美相关资料。

**Declare 申明**

**This specification is written both in English and in Chinese and the latter is formal.**  
产品规格书以中英文方式书写，若有冲突以中文版本为准。