

# DATASHEET

## Architectural light Lens S01.01.02.101 \_SG-D15.2-1-13

### 1.General Information

- ✓ Material : PMMA
- ✓ Size : D15.2 (mm)
- ✓ FWHM : 13°
- ✓ Design LED : CREE XPE 3535
- ✓ Compatible LED size : 3030/3535
- ✓ Efficiency : 93%
- ✓ Fasten : Glue/PIN
- ✓ IP class : N/A
- ✓ Accessories : cylindrical holder with position PIN
- ✓ RoHS : YES
- ✓ Surface : Bead Matt



### 2.MECHANICAL SPECIFICATION

UNIT:MM

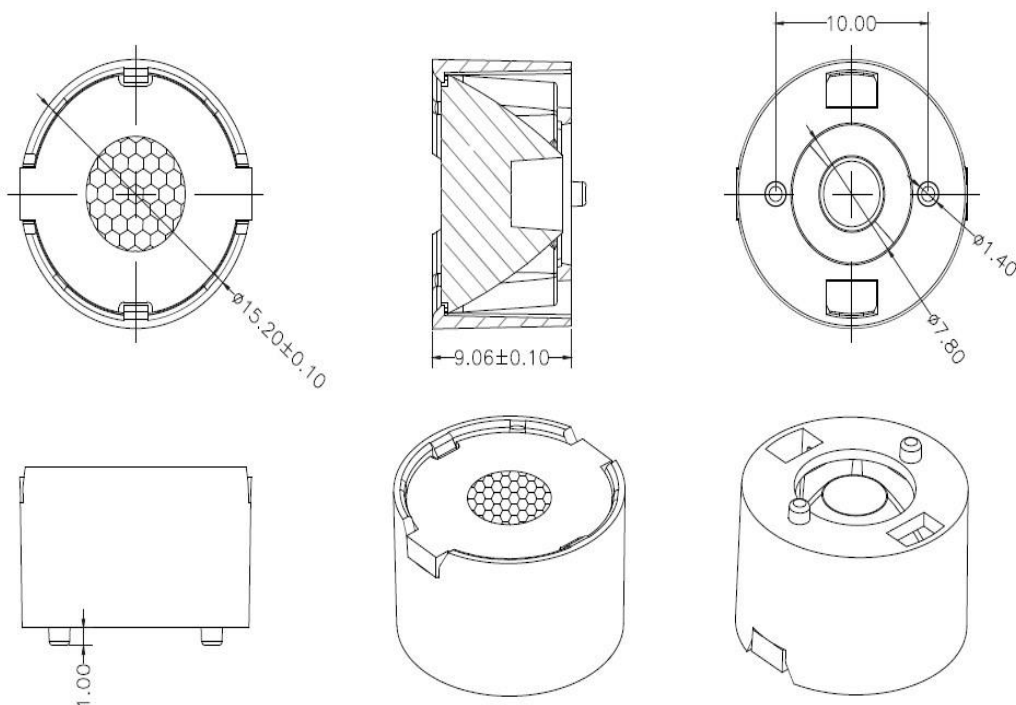

## 3.OPTICAL DATA

### 1) Simulation Data

Brand : CREE XPE

LED model : 3535

Light colour : White

FWTM : H28.1°,V28°

FWHM : H12.9°,V12.9°

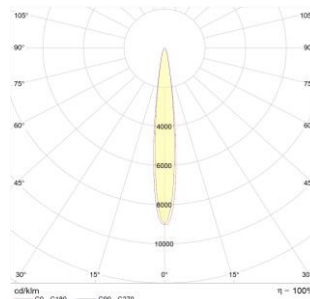

### 2) Test Data

Brand : Not simulate

LED model : Not simulate

Light colour : Not simulate

FWTM : Not simulate

FWHM : Not simulate

## 4.Usage and Maintenance

- 1) If necessary, clean lenses with mild soap, water and soft cloth.
- 2) Never use any commercial cleaning solvents on lenses, like alcohol.
- 3) Please handle lens with wearing gloves, skin oils may damage lens or its optical characteristic.

## 5.Note

Please test the data again before using. The chart data is for reference only.