



# LONTIUM SEMICONDUCTOR CORPORATION

ClearEdge™ Technology

**LT9211**

**MIPI/TTL/2-Port LVDS  
to MIPI/TTL/2-Port LVDS Converter**

**Datasheet**



# 1. Features

## ● MIPI Transmitter

- Compliant with DCS1.02, D-PHY1.2 ,DSI1.2 and CSI-2 1.00
- 1 Clock Lane and 1~4 Configurable Data Lanes
- Two Port Simultaneous Display Supported
- Up to 1.8Gb/s per Data Lane
- Resolution Up to 1920x1200 60Hz or any other Resolution whose Pixel Clk less than 200MHz
- Data Lane and Polarity Swapping
- Both Non-Burst and Burst Video Mode Supported
- Support RGB666, Loosely RGB666, RGB888, RGB565, 16-bit YCbCr4:2:2, 24-bit YCbCr 4:2:2 Video Format

## ● Dual-Port LVDS Transmitter

- Compatible with VESA and JEIDA standard
- 1~2 Configurable Port
- Two Port Simultaneous Display Supported
- Resolution Up to 1920x1200 60Hz or any other Resolution whose Pixel Clk less than 200MHz
- Support DE Mode
- Data Port , Data Lane and Polarity Swapping
- Programmable Pre-emphasis
- Support output SSC(30KHz±5%)

## ● TTL Output

- Support 24-bit RGB and BT656/BT1120
- Both DDR and SDR Sampling supported
- Support both 1.8V and 3.3V Voltage Output
- Resolution Up to 1920x1200 60Hz or any other Resolution whose Pixel Clk less than 200MHz

## ● MIPI Receiver

- Compliant with DCS1.02, D-PHY1.2 ,DSI1.2 and CSI-2 1.00
- 1 Clock Lane and 1~4 Configurable Data Lanes
- Two Port Input switchable
- Up to 1.8Gb/s per Data Lane
- Resolution Up to 1920x1200 60Hz or any other Resolution whose Pixel Clk less than 200MHz
- Data Lane and Polarity Swapping
- Both Non-Burst and Burst Video Mode Supported
- Support RGB666, Loosely RGB666, RGB888, RGB565,

16-bit YCbCr4:2:2, 24-bit YCbCr 4:2:2 Video Format

## ● Dual-Port LVDS Receiver

- Compatible with VESA and JEIDA standard
- 1~2 Configurable Port
- Resolution Up to 1920x1200 60Hz or any other Resolution whose Pixel Clk less than 200MHz
- Support DE Mode
- Data Port , Data Lane and Polarity Swapping
- Internal Rterm Calibration with Less than 5% Error
- Support input Dessc(30KHz±5%)

## ● TTL Input

- Support 24-bit RGB and BT656/BT1120
- Both DDR and SDR Sampling supported
- Support SYNC Mode and DE Mode
- Support both 1.8V and 3.3V Input Voltage
- Resolution Up to 1920x1200 60Hz or any other Resolution whose Pixel Clk less than 200MHz

## ● Miscellaneous

- 1.8V and 3.3V Power Supply
- Alternative Input and Output configuration for LVDS/TTL/MIPI
- MIPI/LVDS muxer and splitter supported
- MIPI-LVDS level shifter for FPGA Application
- Support 100KHz and 400KHz I2C Slave
- External 25MHz ± 200ppm Crystal Reference Clock is Preferred
- Temperature Range: -40°C ~ +85°C
- Packaged in QFN64 7.5mm x 7.5mm

# 2. General Description

The Lontium LT9211 is a high performance converter which interconvertible between MIPI DSI/CSI-2/Dual-Port LVDS and TTL except for 24bit TTL to 24bit TTL with both SYNC and DE. The LT9211 deserializes input MIPI/LVDS/TTL video data, decodes packets, and converts the formatted video data stream to MIPI/LVDS/TTL transmitter output between AP and mobile display panel or camera. The LT9211 can be used as 2-Port MIPI/LVDS Repeater which support maximum 14dB input equalization and programmable pre-emphasis to improve performance.

We produce mixed-signal products for a better digital world!



The LT9211 can also be used as MIPI/LVDS Muxer and Splitter. For MIPI Repeater, Muxer and Splitter, we also support CSI RAW format with continuous clock.

The LT9211 is fabricated in advanced CMOS process and implemented in 7.5x7.5mm QFN64 package. This package is RoHS compliant and specified to operate from -40°C to +85°C.

### 3. Applications

- Mobile systems
- Cellular handsets
- Digital video cameras
- Digital still cameras
- Tablet PC, Notebook PC
- Car Display and Camera System

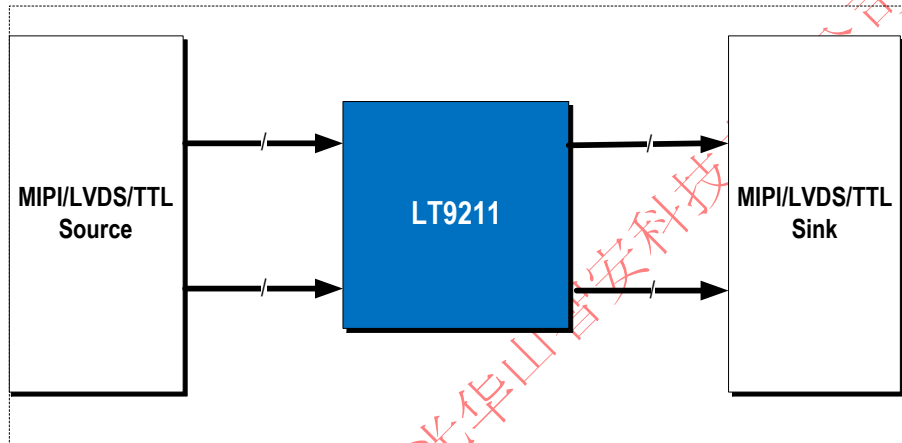

Figure 3.1 LT9211 Typical Application Diagram

### 4. Ordering Information

Table 4.1 Ordering Information

Part Number	Product Version	Product Status	Operating Temperature Range	Package	Packing Method	MPQ
LT9211	U2	NRND	-40°C to +85°C	QFN64 (7.5*7.5)	Tray	2600pcs
LT9211	U4	NRND	-40°C to +85°C	QFN64 (7.5*7.5)	Tray	2600pcs
LT9211_U5	U5	MP	-40°C to +85°C	QFN64 (7.5*7.5)	Tray	2600pcs

NRND: Not Recommended for New Designs.  
MP: Mass Production.

Table 4.2 IC Version Information

Product Version	Information	Note
U2	1. If the MIPI source does not have "eotp packet", LT9211's MIPI Receiver do not work well. Any other conversions between MIPI DSI/CSI-2/Dual-Port LVDS and TTL are OK;	

We produce mixed-signal products for a better digital world!



	2. MIPI Port-B input do not work well in non-continuous clock mode.	
U4	1. MIPI Receiver solved the issue which MIPI source does not have “eotp packet”; 2. MIPI Port-B input do not work well in non-continuous clock mode.	
U5	1. MIPI Repeater support CSI RAW format with continuous clock; 2. Add TTL output dclk phase adjust function, this does not apply to LVDS with SSC and MIPI input; 3. Solved MIPI Port-B input non-continuous clock issue.	

Lontium Confidential for 重庆紫光华山智安科技有限公司 Use Only



## Table of Contents

<b>1. Features</b> .....	<b>2</b>
<b>2. General Description</b> .....	<b>2</b>
<b>3. Applications</b> .....	<b>3</b>
<b>4. Ordering Information</b> .....	<b>3</b>
<b>5. Revision History</b> .....	<b>6</b>
<b>6. Pinning Information</b> .....	<b>7</b>
6.1 Pin Configuration.....	7
6.2 Pin Description.....	8
<b>7. Function Description</b> .....	<b>11</b>
7.1 Function Block Diagram .....	11
<b>8. Specification</b> .....	<b>12</b>
8.1 Absolute Maximum Conditions.....	12
8.2 Normal Operating Conditions .....	12
8.3 DC Characteristics .....	12
8.4 AC Characteristics .....	13
8.5 Power Consumption.....	17
8.6 Power-up and Reset Sequence .....	18
<b>9. Package Information</b> .....	<b>19</b>
9.1 ePad Enhancement.....	19
9.2 Package Dimensions .....	19
9.3 Packing Dimensions.....	20

Lontium Confidential for 重庆紫光华山智安科技有限公司 Use Only



## 5. Revision History

Version	Owner	Content	Date
R1.0	Y C	Initial U5 datasheet creation	03/03/2021
R1.1	Y C	Modify Figure 8.4.3 LVDS 8-bit JIEDA DATA lane-2 Mapping	04/30/2021

Lontium Confidential for 重庆紫光华山智安科技有限公司 Use Only



## 6. Pinning Information

### 6.1 Pin Configuration

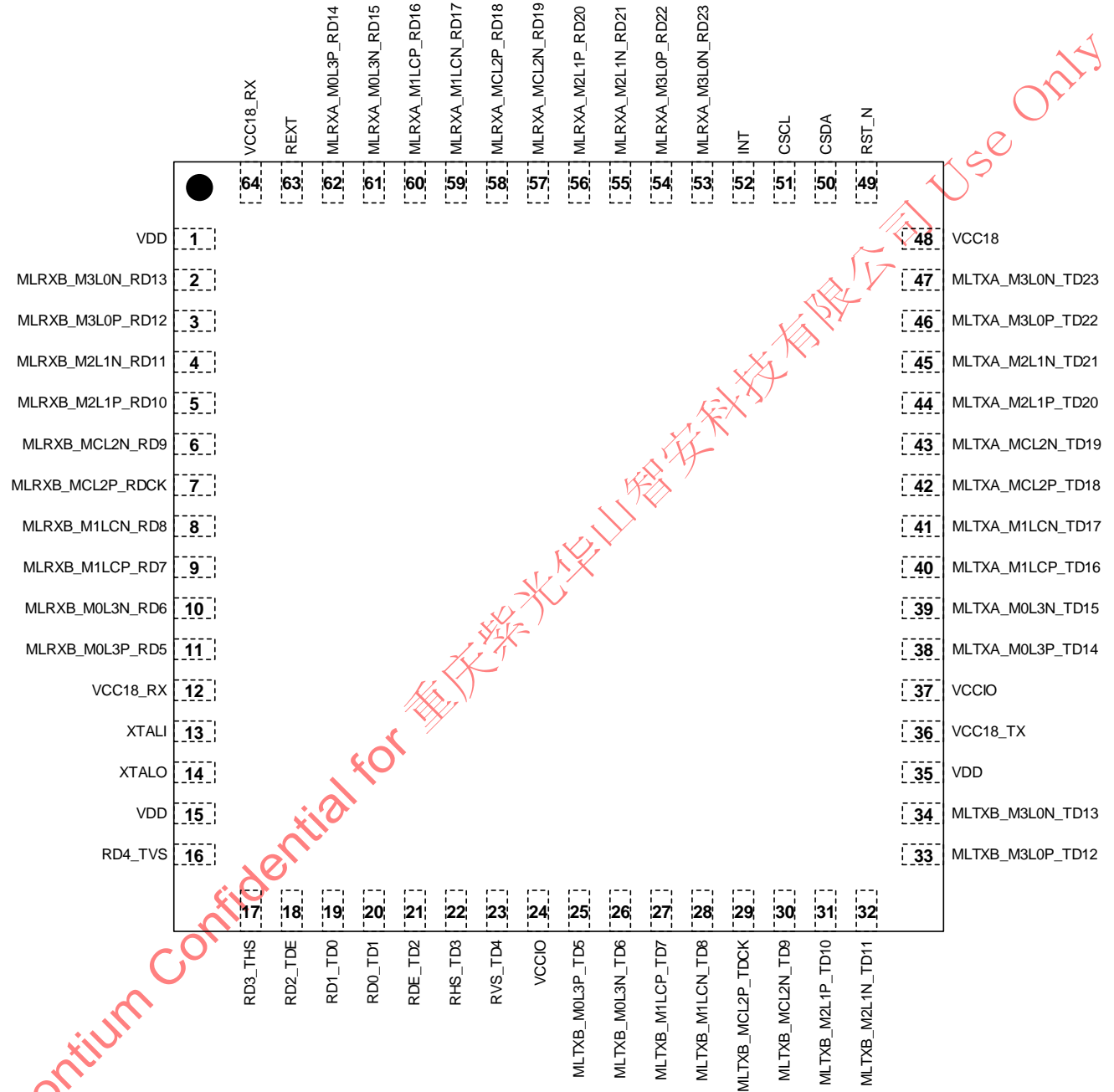

Figure 6.1.1 QFN64 Pin Configuration



## 6.2 Pin Description

Table 6.2.1 QFN64 Pin Description

PIN#	PIN NAME	I/O TYPE	I/O DIR	DESCRIPTION
53,54	MLRXA_M3L0N_RD23 MLRXA_M3L0P_RD22	MIPI LVDS LVTTTL	I	<b>Port-A MIPIRX Lane-3/LVDSRX Lane-0 and TTL Input</b> MIPI input of polarity swappable differential pairs up to 1.8Gb/s ; LVDS input of polarity swappable differential pairs up to 1.2Gb/s ; TTL input up to 200Mbps.
55,56	MLRXA_M2L1N_RD21 MLRXA_M2L1P_RD20	MIPI LVDS LVTTTL	I	<b>Port-A MIPIRX Lane-2/LVDSRX Lane-1 and TTL Input</b> MIPI input of polarity swappable differential pairs up to 1.8Gb/s ; LVDS input of polarity swappable differential pairs up to 1.2Gb/s ; TTL input up to 200Mbps.
57,58	MLRXA_MCL2N_RD19 MLRXA_MCL2P_RD18	MIPI LVDS LVTTTL	I	<b>Port-A MIPIRX Lane-C/LVDSRX Lane-2 and TTL Input</b> MIPI input of polarity swappable differential pairs up to 1.8Gb/s ; LVDS input of polarity swappable differential pairs up to 1.2Gb/s ; TTL input up to 200Mbps.
59,60	MLRXA_M1LCN_RD17 MLRXA_M1LCP_RD16	MIPI LVDS LVTTTL	I	<b>Port-A MIPIRX Lane-1/LVDSRX Lane-C and TTL Input</b> MIPI input of polarity swappable differential pairs up to 1.8Gb/s ; LVDS input of polarity swappable differential pairs up to 1.2Gb/s ; TTL input up to 200Mbps.
61,62	MLRXA_M0L3N_RD15 MLRXA_M0L3P_RD14	MIPI LVDS LVTTTL	I	<b>Port-A MIPIRX Lane-0/LVDSRX Lane-3 and TTL Input</b> MIPI input of polarity swappable differential pairs up to 1.8Gb/s ; LVDS input of polarity swappable differential pairs up to 1.2Gb/s ; TTL input up to 200Mbps.
2,3	MLRXB_M3L0N_RD13 MLRXB_M3L0P_RD12	MIPI LVDS LVTTTL	I	<b>Port-B MIPIRX Lane-3/LVDSRX Lane-0 and TTL Input</b> MIPI input of polarity swappable differential pairs up to 1.8Gb/s ; LVDS input of polarity swappable differential pairs up to 1.2Gb/s ; TTL input up to 200Mbps.
4,5	MLRXB_M2L1N_RD11 MLRXB_M2L1P_RD10	MIPI LVDS LVTTTL	I	<b>Port-B MIPIRX Lane-2/LVDSRX Lane-1 and TTL Input</b> MIPI input of polarity swappable differential pairs up to 1.8Gb/s ; LVDS input of polarity swappable differential pairs up to 1.2Gb/s ; TTL input up to 200Mbps.
6,7	MLRXB_MCL2N_RD9 MLRXB_MCL2P_RDCK	MIPI LVDS LVTTTL	I	<b>Port-B MIPIRX Lane-C/LVDSRX Lane-2 and TTL Input</b> MIPI input of polarity swappable differential pairs up to 1.8Gb/s ; LVDS input of polarity swappable differential pairs up to 1.2Gb/s ; TTL input up to 200Mbps.
8,9	MLRXB_M1LCN_RD8	MIPI	I	<b>Port-B MIPIRX Lane-1/LVDSRX Lane-C and TTL Input</b>

We produce mixed-signal products for a better digital world!





PIN#	PIN NAME	I/O TYPE	I/O DIR	DESCRIPTION
	MLRXB_M1LCP_RD7	LVDS LVTTTL		MIPI input of polarity swappable differential pairs up to 1.8Gb/s ; LVDS input of polarity swappable differential pairs up to 1.2Gb/s ; TTL input up to 200Mbps.
10,11	MLRXB_M0L3N_RD6 MLRXB_M0L3P_RD5	MIPI LVDS LVTTTL	I	<b>Port-B MIPIRX Lane-0/LVDSRX Lane-3 and TTL Input</b> MIPI input of polarity swappable differential pairs up to 1.8Gb/s ; LVDS input of polarity swappable differential pairs up to 1.2Gb/s ; TTL input up to 200Mbps.
16,17 18,19 20,21 22,23	RD4_TVS,RD3_THS RD2_TDE,RD1_TD0 RD0_TD1,RDE_TD2 RHS_TD3,RVS_TD4	LVTTTL	I/O	<b>TTL Data and Control Signal and Debug GPO Output</b> These Pins can be selected as TTL input or output. Also, they can be configured as outputs for debug function.
38,39	MLTXA_M0L3P_TD14 MLTXA_M0L3N_TD15	MIPI LVDS LVTTTL	O	<b>Port-A MIPITX Lane-0/LVDSTX Lane-3 and TTL Output</b> MIPI output of polarity swappable differential pairs up to 1.8Gb/s ; LVDS output of polarity swappable differential pairs up to 1.2Gb/s ; TTL output up to 200Mbps.
40,41	MLTXA_M1LCP_TD16 MLTXA_M1LCN_TD17	MIPI LVDS LVTTTL	O	<b>Port-A MIPITX Lane-1/LVDSTX Lane-C and TTL Output</b> MIPI output of polarity swappable differential pairs up to 1.8Gb/s ; LVDS output of polarity swappable differential pairs up to 1.2Gb/s ; TTL output up to 200Mbps.
42,43	MLTXA_MCL2P_TD18 MLTXA_MCL2N_TD19	MIPI LVDS LVTTTL	O	<b>Port-A MIPITX Lane-C/LVDSTX Lane-2 and TTL Output</b> MIPI output of polarity swappable differential pairs up to 1.8Gb/s ; LVDS output of polarity swappable differential pairs up to 1.2Gb/s ; TTL output up to 200Mbps.
44,45	MLTXA_M2L1P_TD20 MLTXA_M2L1N_TD21	MIPI LVDS LVTTTL	O	<b>Port-A MIPITX Lane-2/LVDSTX Lane-1 and TTL Output</b> MIPI output of polarity swappable differential pairs up to 1.8Gb/s ; LVDS output of polarity swappable differential pairs up to 1.2Gb/s ; TTL output up to 200Mbps.
46,47	MLTXA_M3L0P_TD22 MLTXA_M3L0N_TD23	MIPI LVDS LVTTTL	O	<b>Port-A MIPITX Lane-3/LVDSTX Lane-0 and TTL Output</b> MIPI output of polarity swappable differential pairs up to 1.8Gb/s ; LVDS output of polarity swappable differential pairs up to 1.2Gb/s ; TTL output up to 200Mbps.
25,26	MLTXB_M0L3P_TD5 MLTXB_M0L3N_TD6	MIPI LVDS LVTTTL	O	<b>Port-B MIPITX Lane-0/LVDSTX Lane-3 and TTL Output</b> MIPI output of polarity swappable differential pairs up to 1.8Gb/s ; LVDS output of polarity swappable differential pairs up to 1.2Gb/s ; TTL output up to 200Mbps.
27,28	MLTXB_M1LCP_TD7 MLTXB_M1LCN_TD8	MIPI LVDS	O	<b>Port-B MIPITX Lane-1/LVDSTX Lane-C and TTL Output</b> MIPI output of polarity swappable differential pairs up to

We produce mixed-signal products for a better digital world!



PIN#	PIN NAME	I/O TYPE	I/O DIR	DESCRIPTION
		LVTTTL		1.8Gb/s ; LVDS output of polarity swappable differential pairs up to 1.2Gb/s ; TTL output up to 200Mbps.
29,30	MLTXB_MCL2P_TDCK MLTXB_MCL2N_TD9	MIPI LVDS LVTTTL	O	<b>Port-B MIPITX Lane-C/LVDSTX Lane-2 and TTL Output</b> MIPI output of polarity swappable differential pairs up to 1.8Gb/s ; LVDS output of polarity swappable differential pairs up to 1.2Gb/s ; TTL output up to 200Mbps.
31,32	MLTXB_M2L1P_TD10 MLTXB_M2L1N_TD11	MIPI LVDS LVTTTL	O	<b>Port-B MIPITX Lane-2/LVDSTX Lane-1 and TTL Output</b> MIPI output of polarity swappable differential pairs up to 1.8Gb/s ; LVDS output of polarity swappable differential pairs up to 1.2Gb/s ; TTL output up to 200Mbps.
33,34	MLTXB_M3L0P_TD12 MLTXB_M3L0N_TD13	MIPI LVDS LVTTTL	O	<b>Port-B MIPITX Lane-3/LVDSTX Lane-0 and TTL Output</b> MIPI output of polarity swappable differential pairs up to 1.8Gb/s ; LVDS output of polarity swappable differential pairs up to 1.2Gb/s ; TTL output up to 200Mbps.
63	REXT	Analog	I/O	<b>BandGap External Resistor</b> External 6.04K (1%) resistor tie to ground for setting internal reference current.
13,14	XTALI XTALO	LVTTTL	I/O	<b>25M Crystal oscillator interface</b> A 25MHz±200ppm Crystal is Preferred.
49	RST_N	LVTTTL	I	<b>Hardware Reset Input</b> Chip reset signal, active low, both 1.8V and 3.3V voltage level should be OK.
50,51	CSDA CSCL	LVTTTL OPD	I/O	<b>I2C Serial Clk and Data Input and Output</b> It serves as 3.3V or 1.8V serial port clk and data IO slave for register access. The I2C device address is 0x5A.
52	INT	LVTTTL OPD	I/O	<b>Interrupt Request Output</b> This pin is interrupt request output. It can be configured as Open-drain or CMOS output, when configured as CMOS output, the output high voltage is 1.8V.
12,64	VCC18_RX	PG	I/O	<b>1.8V RX Power</b> 1.8V power for RX.
36	VCC18_TX	PG	I/O	<b>1.8V TX Power</b> 1.8V power for TX.
24,37	VCCIO	PG	N/A	<b>IO Power</b> 1.8V or 3.3V power for TTL input and output. When 3.3V TTL voltage level input, it should be connect to 3.3V. For TTL output, the output high-voltage is VCCIO.
48	VCC18	PG	N/A	<b>1.8V Power for Control Signal</b> 1.8V power for control signal.
1,15,35	VDD	PG	N/A	<b>1.8V Power</b> 1.8V power for digital block.

We produce mixed-signal products for a better digital world!



# 7. Function Description

## 7.1 Function Block Diagram

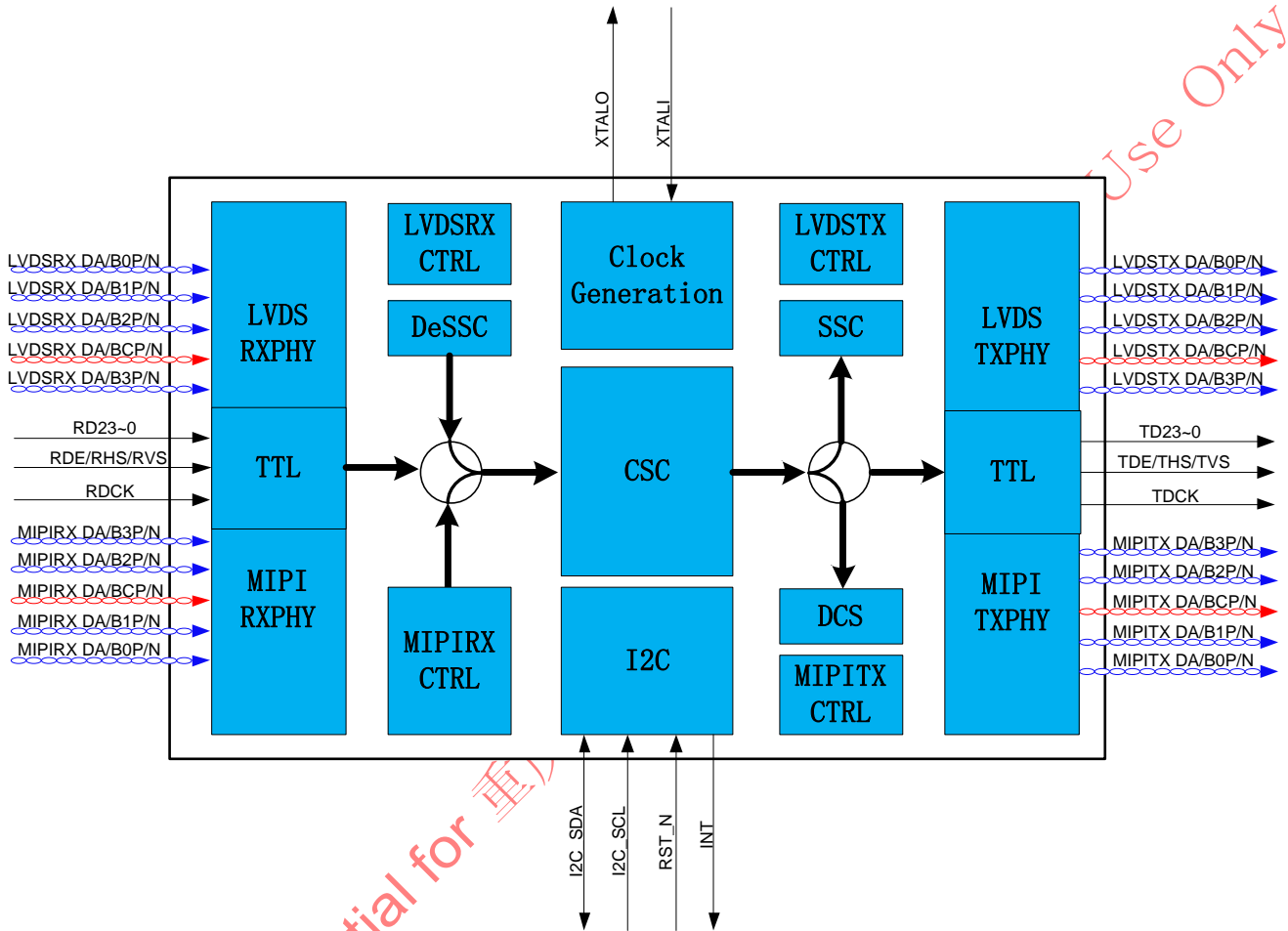

Figure 7.1.1 Function Block Diagram



## 8. Specification

### 8.1 Absolute Maximum Conditions

Table 8.1.1 Absolute Maximum Conditions

SYMBOL	DESCRIPTION	MIN	TYP	MAX	Unit
VCC18_RX, VCC18_TX VCC18,VDD	1.8V Power Supply Voltage	-0.3		2.4	V
VCCIO	1.8V/3.3V Power Supply Voltage	-0.3		4	V
V <sub>I</sub> / V <sub>O</sub>	CMOS Terminal Input/output Voltage Range	-0.3		VCCIO+ 0.3	V
T <sub>s</sub>	Storage Temperature	-65		150	°C
T <sub>J</sub>	Junction Temperature			125	°C
ESD	HBM Electrostatic Discharge Level		±2K		V
	CDM Electrostatic Discharge Level		±500		V

**Note:** Permanent device damage may occur if absolute maximum conditions are exceeded.

### 8.2 Normal Operating Conditions

Table 8.2.1 Normal Operating Conditions

SYMBOL	DESCRIPTION	MIN	TYP	MAX	Unit
VCC18_RX, VCC18_TX VCC18,VDD	1.8V Power Supply Voltage	1.62	1.8	1.98	V
VCCIO	1.8V Power Supply Voltage	1.62		1.98	V
	3.3V Power Supply Voltage	2.97		3.63	V
T <sub>A</sub>	Operating Free-air Temperature	-40	27	85	°C
θ <sub>Jc</sub>	Junction to Case Thermal Resistance		9.3		°C/W

### 8.3 DC Characteristics

Table 8.3.1 DC Characteristics

MIPI HS Line Receiver DC Specifications					
Symbol	Parameter	MIN	TYP	MAX	Unit
VIDTH	Differential input high voltage threshold			70	mV
VIDTL	Differential input low voltage threshold	-70			mV
VIHHS	Single ended input high voltage			460	mV
VILHS	Single ended input low voltage	-40			mV
VCMRXDC	Input common mode voltage	70	200	330	mV
Rterm	Differential input impedance	80	100	125	Ω
MIPI LP Line Receiver DC Specifications					
Symbol	Parameter	MIN	TYP	MAX	Unit
VIL	Input low voltage			550	mV
VIH	Input high voltage, data rate<1.5Gbps	880			mV
	Input high voltage, data rate>1.5Gbps	740			mV
VHYST	Input hysteresis	25			mV

We produce mixed-signal products for a better digital world!



MIPI HS Line Transmitter DC Specifications					
Symbol	Parameter	MIN	TYP	MAX	Unit
Vcm	HS Transmit Static Common mode Voltage	150	200	250	mV
Vod	HS Transmit Differential Voltage	140	200	270	mV
Vohhs	HS Transmit Output High Voltage			360	mV
Zos	Single ended output impedance	40	50	62.5	$\Omega$
MIPI LP Line Transmitter DC Specifications					
Symbol	Parameter	MIN	TYP	MAX	Unit
VOL	Output low-level SE voltage	-50	0	50	mV
VOH	Output high-level SE voltage	1.1	1.2	1.3	V
ZOLP	Single-ended output impedance	110			$\Omega$
LVDS Receiver DC Specifications					
Symbol	Parameter	MIN	TYP	MAX	Unit
WIDTH	Differential input high voltage threshold			50	mV
VIDTL	Differential input low voltage threshold	-50			mV
VCMRXDC	Input common mode voltage	0	1200	1800	mV
Rterm	Termination Resister	80	100	125	$\Omega$
LVDS Transmitter DC Specifications					
Symbol	Parameter	MIN	TYP	MAX	Unit
VOD	Differential Out Voltage: RL=100 $\Omega$	150	350	500	mV
VOC	Common Mode Voltage: RL=100 $\Omega$	1.1	1.25	1.4	V
LVTTTL I/O DC Specifications					
Symbol	Parameter	Min	Typ	Max	Unit
VIH	Input high voltage	1.2			V
VIL	Input low voltage			0.6	V
VOH	1.8V Output high voltage	1.3			V
	3.3V Output high voltage	2.4			
VOL	1.8V Output low voltage			0.4	V
	3.3V Output low voltage			0.4	

## 8.4 AC Characteristics

Table 8.4.1 AC Characteristics

MIPI HS Line Receiver AC Specifications					
Symbol	Parameter	MIN	TYP	MAX	Unit
$\Delta$ VCMRX(HF)	Common mode interference beyond 450MHz			200	mVpp
$\Delta$ VCMRX(LF)	Common mode interference between 50MHz and 450MHz	-50		50	mVpp
Ccm	Common mode termination			60	pF
MIPI LP Line Receiver AC Specifications					
Symbol	Parameter	MIN	TYP	MAX	Unit
eSPIKE	Input pulse rejection			300	V.ps
TMIN	Minimum pulse response	20			ns
VINT	Peak interference voltage			200	mV
fINT	Interference frequency	450			MHz
MIPI HS Line Transmitter AC Specifications					

We produce mixed-signal products for a better digital world!



Symbol	Parameter	MIN	TYP	MAX	Unit
$\Delta V_{cmx}(hf)$	Common mode Voltage variation above 450MHz			15	mVrms
$\Delta V_{cmx}(lf)$	Common mode Voltage variation between 50-450MHz			25	mVpeak
Rise/Fall Time 20%-80%	Data rate <1Gbps	150		0.3UI	ps
	Data rate 1Gbps~1.5Gbps	100		0.35UI	ps
	Data rate >1.5Gbps	50		0.4UI	ps

**MIPI LP Line Transmitter AC Specifications**

Symbol	Parameter	MIN	TYP	MAX	Unit
trlp , tflp	Single ended output rise/fall time, 15% to 85%, CL< 70pF			25	ns
treat	Single ended output rise/fall time, 30% to 85%, CL< 70pF			35	ns

**LVDS Receiver AC Specifications**

Symbol	Parameter	MIN	TYP	MAX	Unit
Tc	output clk cycle	6.25		37	ns
T0	Input data position0	-0.15	0	0.15	ns
T1	Input data position1	Tc/7-0.15		Tc/7+0.15	ns
T2	Input data position2	2Tc/7-0.15		2Tc/7+0.15	ns
T3	Input data position3	3Tc/7-0.15		3Tc/7+0.15	ns
T4	Input data position4	4Tc/7-0.15		4Tc/7+0.15	ns
T5	Input data position5	5Tc/7-0.15		5Tc/7+0.15	ns
T6	Input data position6	6Tc/7-0.15		6Tc/7+0.15	ns

**LVDS Transmitter AC Specifications**

Symbol	Parameter	MIN	TYP	MAX	Unit
Tc	output clk cycle	6.25		37	ns
trise	VOD rise time, 20% to 80%	250	350	500	ps
tfall	VOD fall time, 20% to 80%	250	350	500	ps
T0	Output data position0	-0.15	0	0.15	ns
T1	Output data position1	Tc/7-0.15		Tc/7+0.15	ns
T2	Output data position2	2Tc/7-0.15		2Tc/7+0.15	ns
T3	Output data position3	3Tc/7-0.15		3Tc/7+0.15	ns
T4	Output data position4	4Tc/7-0.15		4Tc/7+0.15	ns
T5	Output data position5	5Tc/7-0.15		5Tc/7+0.15	ns
T6	Output data position6	6Tc/7-0.15		6Tc/7+0.15	ns

**TTL Input AC Timing Specifications**

Symbol	Parameter	MIN	TYP	MAX	Unit
T <sub>CIP</sub>	SDR Mode DCK Period, one pixel per clock	5		40	ns
F <sub>CIP</sub>	SDR Mode DCK Frequency, one pixel per clock	25		200	MHz
T <sub>CIP_DDR</sub>	DDR Mode DCK Period, dual-edge clock	10		40	ps
F <sub>CIP_DDR</sub>	DDR Mode DCK Frequency, dual-edge clock	25		100	MHz
T <sub>JITTER</sub>	DCK TIE jitter @1.5M			0.02	T <sub>CIP</sub>
T <sub>DUTY</sub>	SDR Mode DCK Duty Cycle	40%		60%	
T <sub>DUTY_DDR</sub>	DDR Mode DCK Duty Cycle	45%		55%	
T <sub>SDF</sub>	Setup Time to DCK falling edge in SDR mode	1.2			ns
T <sub>HDF</sub>	Hold Time to DCK falling edge in SDR mode	1.2			ns
T <sub>SDR</sub>	Setup Time to DCK rising edge in SDR mode	1.1			ns
T <sub>HDR</sub>	Hold Time to DCK rising edge in SDR mode	1.1			ns
T <sub>SDD</sub>	Setup Time to DCK edge in DDR mode	1.1			ns

We produce mixed-signal products for a better digital world!



T <sub>HDD</sub>	Hold Time to DCK edge in DDR mode	1.2			ns
------------------	-----------------------------------	-----	--	--	----

**TTL Output AC Timing Specifications**

Symbol	Parameter	MIN	TYP	MAX	Unit
T <sub>CIP</sub>	SDR Mode DCK Period, one pixel per clock	5		40	ns
F <sub>CIP</sub>	SDR Mode DCK Frequency, one pixel per clock	25		200	MHz
T <sub>CIP_DDR</sub>	DDR Mode DCK Period, dual-edge clock	10		40	ps
F <sub>CIP_DDR</sub>	DDR Mode DCK Frequency, dual-edge clock	25		100	MHz
T <sub>DUTY</sub>	SDR Mode DCK Duty Cycle	40%		60%	
T <sub>DUTY_DDR</sub>	DDR Mode DCK Duty Cycle	45%		55%	

**Configuration I2C AC Specifications**

Symbol	Parameter	MIN	TYP	MAX	Unit
f <sub>SCL</sub>	I2C clock frequency		100	400	kHz
t <sub>f</sub>	Fall time of both SDA and SCL signals			300	ns
t <sub>r</sub>	Rise time of both SDA and SCL signals			300	ns
t <sub>HD;STA</sub>	Hold time (repeated) START condition. After this period, the first clock pulse is generated	0.6			μs
t <sub>LOW</sub>	Low period of SCL clock	1.3			μs
t <sub>HIGH</sub>	High period of SCL clock	0.6			μs
t <sub>SU;STA</sub>	Setup time for a repeated START condition	0.6			μs
t <sub>HD;DAT</sub>	Data hold time	0.3			μs
t <sub>SU;DAT</sub>	Data setup time	250			ns
t <sub>SU;STO</sub>	Setup time for STOP condition	0.6			μs
t <sub>BUF</sub>	Bus free time between a STOP and START condition	1.3			μs

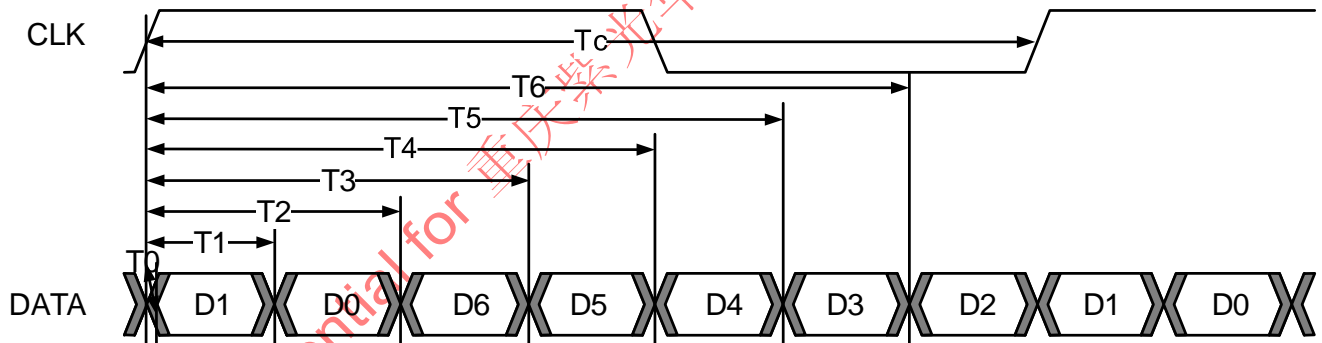

Figure 8.4.1 LVDS Input/Output Clock and Data AC Timing Diagram

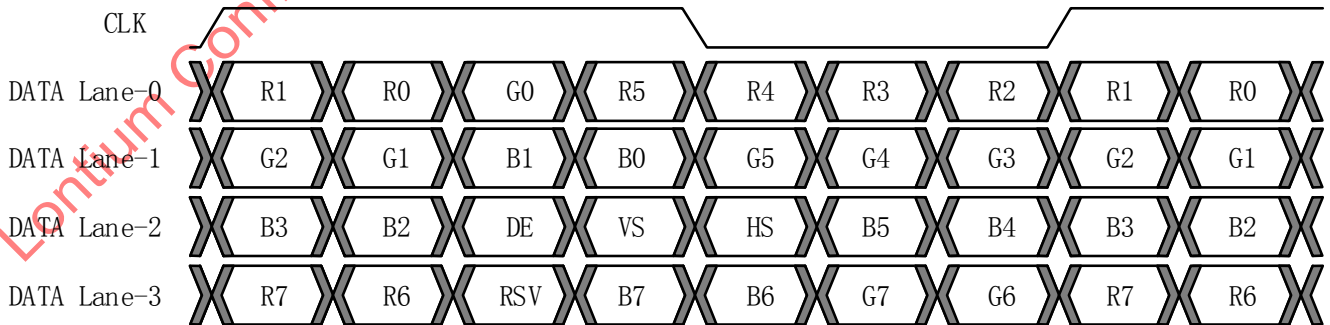

Figure 8.4.2 LVDS 8-bit VESA DATA Mapping

We produce mixed-signal products for a better digital world!

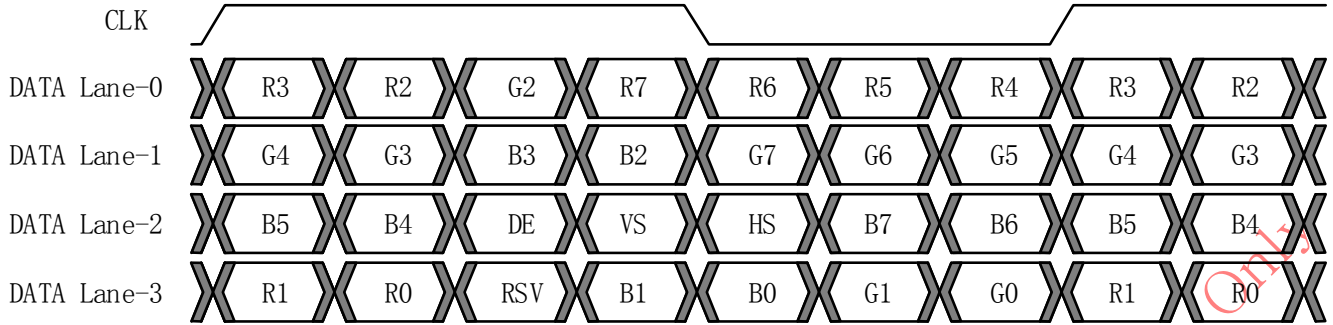

Figure 8.4.3 LVDS 8-bit JIEDA DATA Mapping

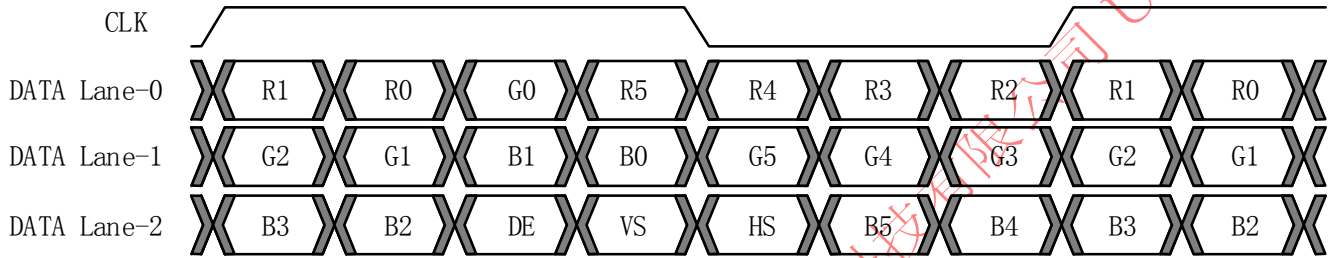

Figure 8.4.4 LVDS 6-bit DATA Mapping

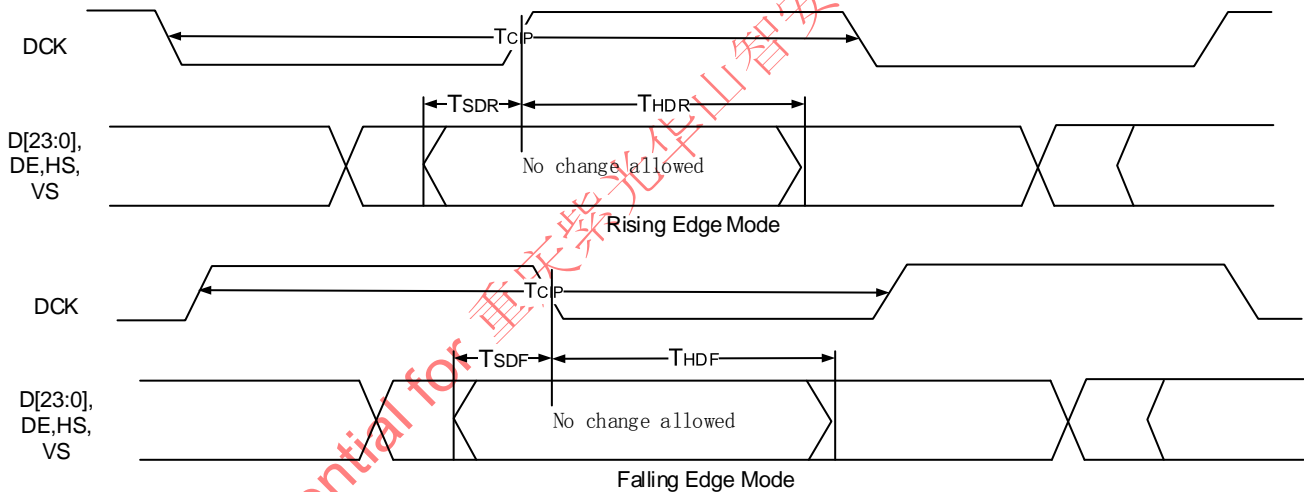

Figure 8.4.5 TTL SDR Mode Data and Clock Timing Diagram6

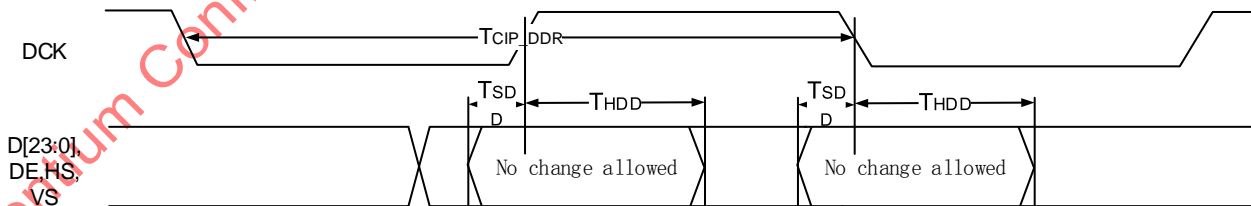

Figure 8.4.6 TTL DDR Mode Data and Clock Timing Diagram

We produce mixed-signal products for a better digital world!



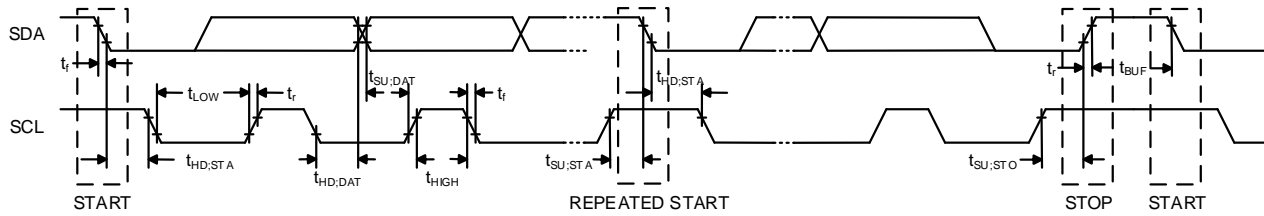

Figure 8.4.7 Configuration I2C Timing Diagram

## 8.5 Power Consumption

Table 8.5.1 MIPI to LVDS Power Consumption

Symbol	Condition	Min	Typ	Max	Unit
Ivcc18	MIPI to 2-Port LVDS @1080P 60Hz		231	252	mA
Ivcc10			1	1	mA

Table 8.5.2 MIPI to TTL Power Consumption

Symbol	Condition	Min	Typ	Max	Unit
Ivcc18	MIPI to BT1120 @1080P 60Hz		155	171	mA
Ivcc10=3.3V			16	17	mA
Ivcc10=1.8V			7	8	

Table 8.5.3 MIPI Splitter Power Consumption

Symbol	Condition	Min	Typ	Max	Unit
Ivcc18	MIPI Splitter @ 1080P 60Hz		255	281	mA
Ivcc10			1	1	mA

Table 8.5.4 LVDS Splitter Power Consumption

Symbol	Condition	Min	Typ	Max	Unit
Ivcc18	LVDS Splitter @ 1080P 60Hz		238	264	mA
Ivcc10			1	1	mA

Table 8.5.5 LVDS to TTL Power Consumption

Symbol	Condition	Min	Typ	Max	Unit
Ivcc18	2-Port LVDS to BT1120 @1080P 60Hz		175	194	mA
Ivcc10=3.3V			17	20	mA
Ivcc10=1.8V			8	9	

Table 8.5.6 LVDS to MIPI Power Consumption

Symbol	Condition	Min	Typ	Max	Unit
Ivcc18	2-Port LVDS to MIPI @1080P 60Hz		242	267	mA
Ivcc10			1	1	mA
Ivcc18	2-Port LVDS to MIPI w/ two Port Simultaneous Display @1080P 60Hz		272	299	mA

We produce mixed-signal products for a better digital world!



Ivccio			1	1	mA
--------	--	--	---	---	----

Table 8.5.7 TTL to MIPI Power Consumption

Symbol	Condition	Min	Typ	Max	Unit
Ivcc18	BT1120 to MIPI @1080P 60Hz w/ Two Port Simultaneous Display		229	252	mA
Ivccio=3.3V			1	1	mA
Ivccio=1.8V			1	1	mA
Ivcc18	BT1120 to Single Port MIPI @1080P 60Hz		199	219	mA
Ivccio=3.3V			1	1	mA
Ivccio=1.8V			1	1	mA

Table 8.5.8 TTL to LVDS Power Consumption

Symbol	Condition	Min	Typ	Max	Unit
Ivcc18	BT1120 to 2-Port LVDS @1080P 60Hz		201	221	mA
Ivccio=3.3V			1	1	mA
Ivccio=1.8V			1	1	

Note: The Typical value is measured at room temperature and VCC18=1.8V, the Maximum value is measured at 80°C and VCC18=1.98V.

### 8.6 Power-up and Reset Sequence

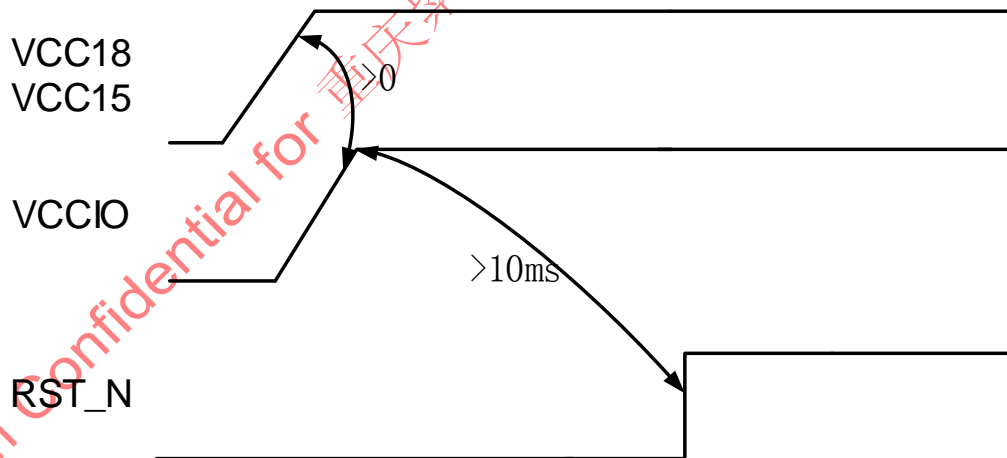

Figure 8.6.1 Power-up Sequence



# 9. Package Information

## 9.1 ePad Enhancement

The LT9211 is packaged in QFN64 package with ePad.

The ePad needs to be soldered to the PCB. The information in the following paragraphs is provided for applications which solder the ePad to the PCB.

The ePad must not be electrically connected to any other voltage level except ground (GND). A clearance of at least 0.25mm should be designed on the PCB between the edge of the ePad and the inner edges of the lead pads to avoid any electrical shorts.

## 9.2 Package Dimensions

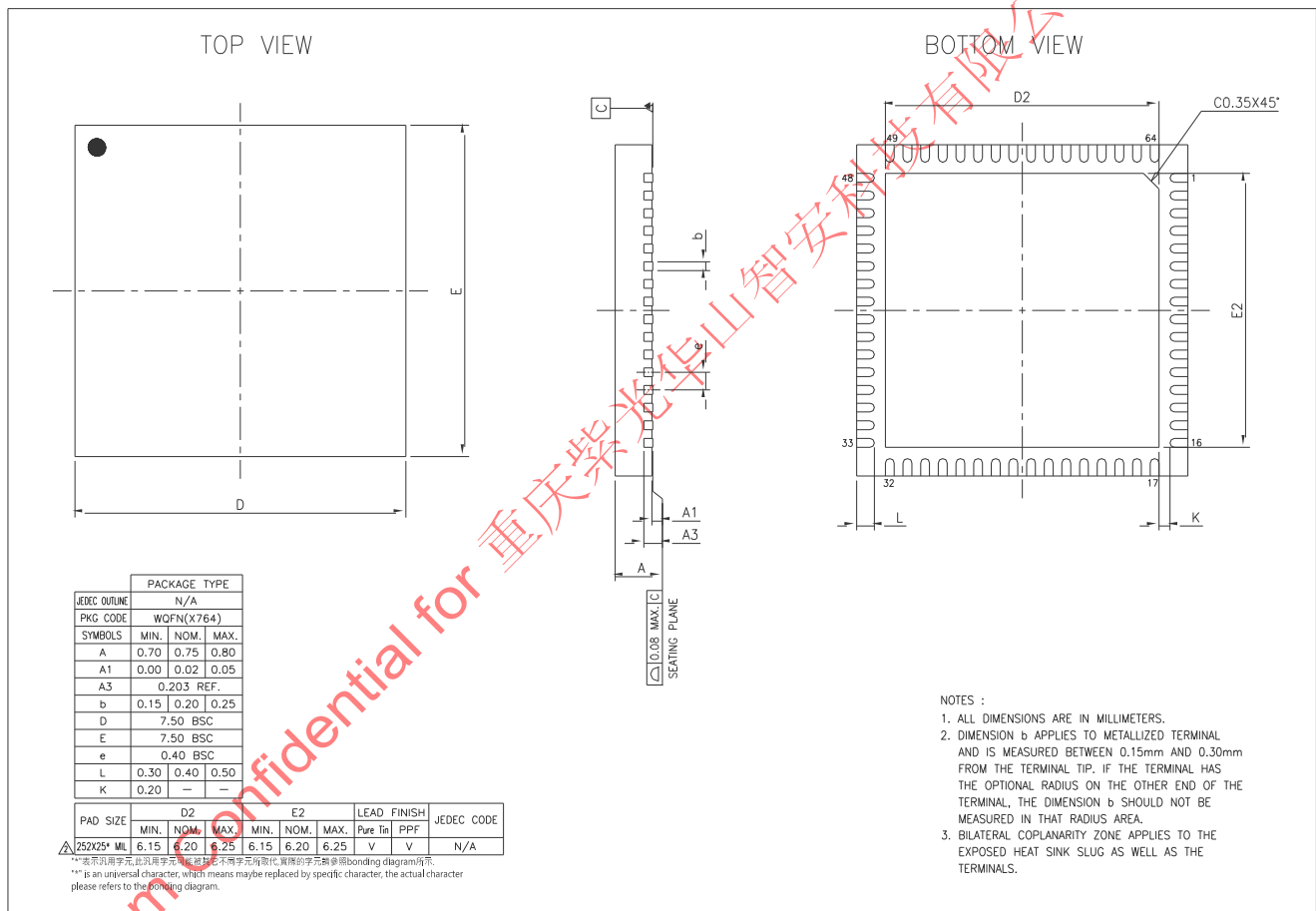
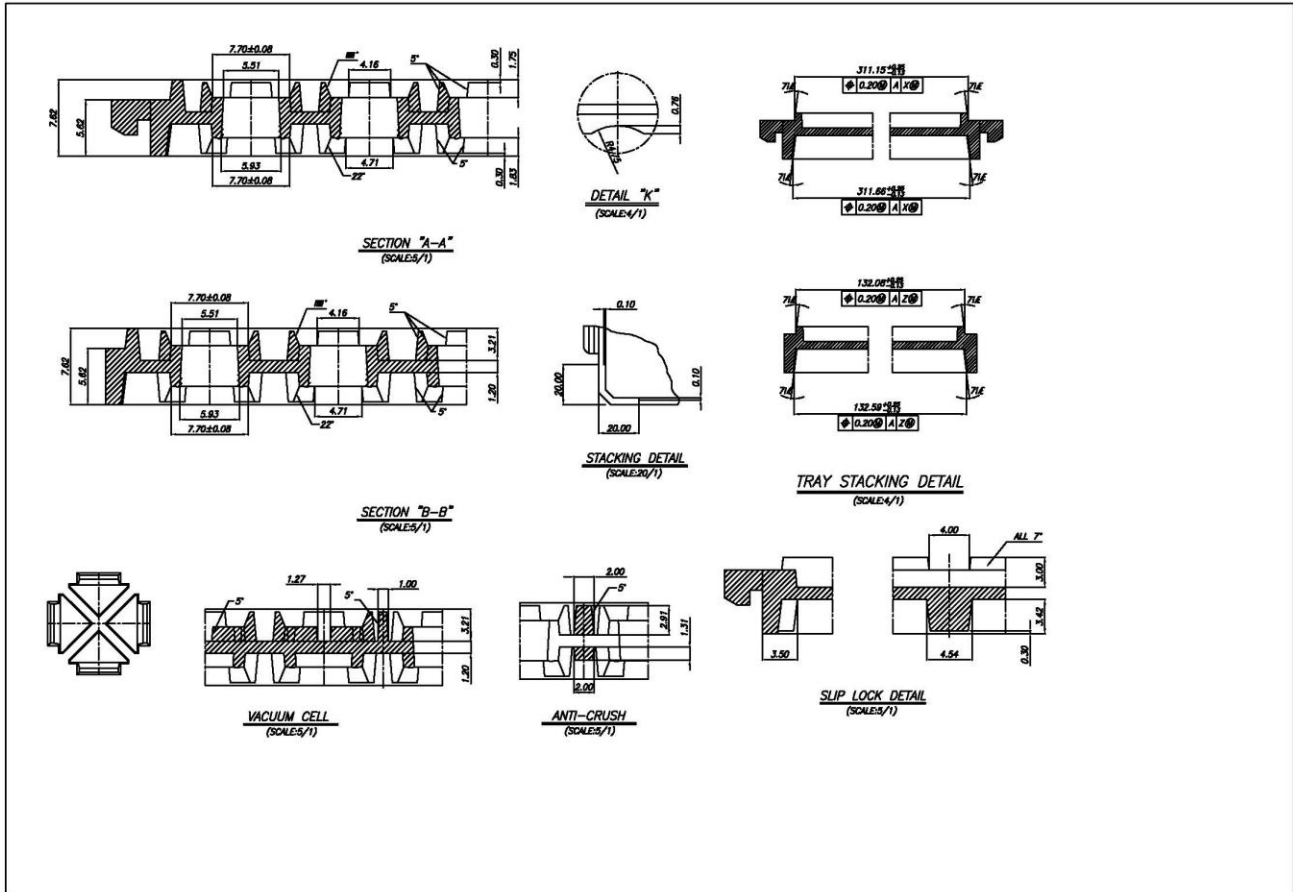

Figure 9.2.1 QFN64 Package Dimensions

We produce mixed-signal products for a better digital world!





Lontium Confidential for 重庆

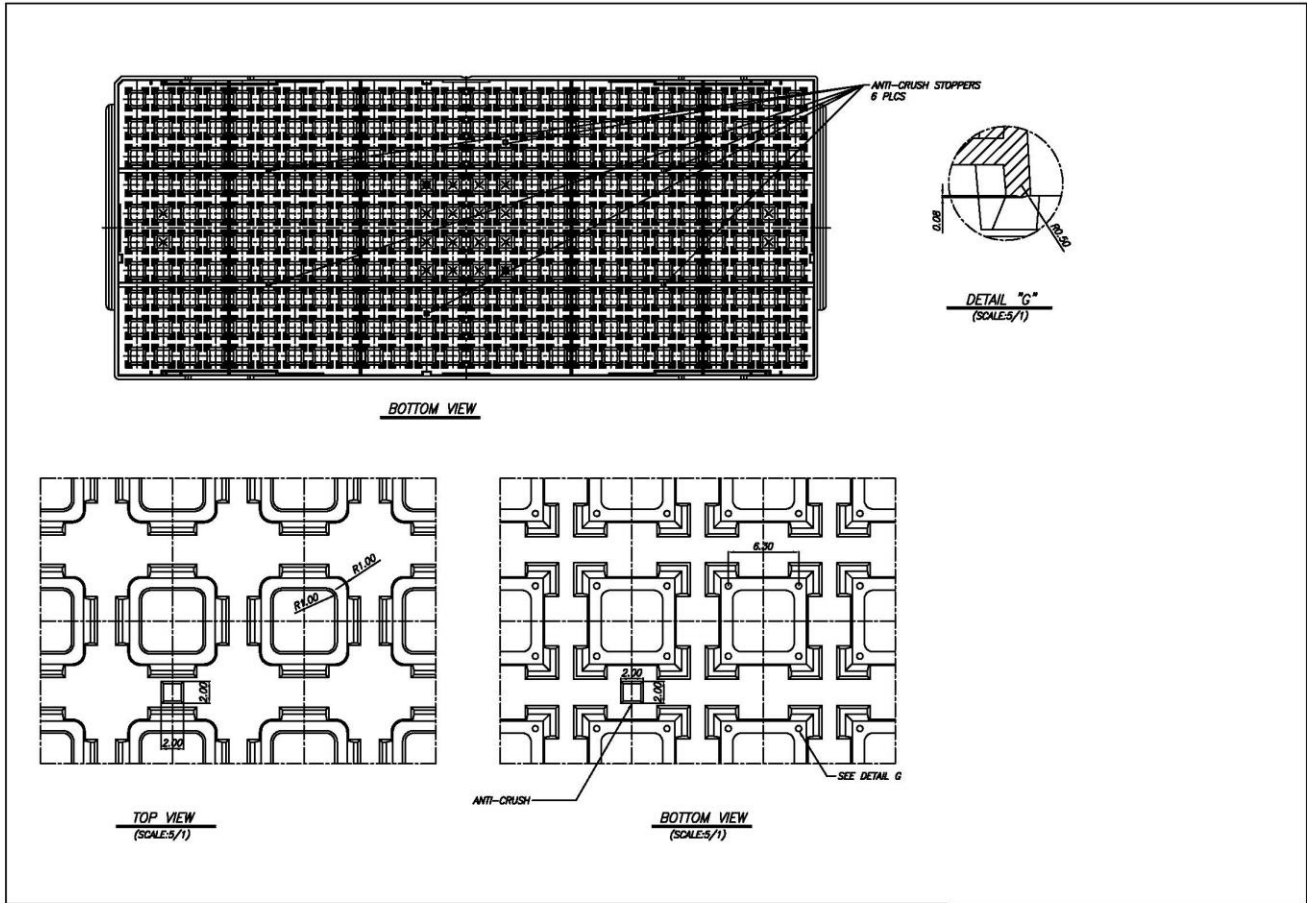

Figure 9.3.1 QFN64 Packing Dimensions

Lontium Confidential for 重慶



---

**Copyright © 2018-2021 Lontium Semiconductor Corporation, All rights reserved.**

**Lontium Semiconductor Proprietary & Confidential**

This document and the information it contains belong to Lontium Semiconductor. Any review, use, dissemination, distribution or copying of this document or its information outside the scope of a signed agreement with Lontium is strictly prohibited.

LONTIUM DISCLAIMS ALL WARRANTIES, EXPRESSED OR IMPLIED, INCLUDING THOSE OF NONINFRINGEMENT, MERCHANTABILITY, TITLE AND FITNESS FOR A PARTICULAR PURPOSE. CUSTOMERS EXPRESSLY ASSUME THEIR OWN RISK IN RELYING ON THIS DOCUMENT.

LONTIUM PRODUCTS ARE NOT DESIGNED OR INTENDED FOR USE IN LIFE SUPPORT APPLIANCES, DEVICES OR SYSTEMS WHERE A MALFUNCTION OF A LONTIUM DEVICE COULD RESULT IN A PERSONAL INJURY OR LOSS OF LIFE.

Lontium assumes no responsibility for any errors in this document, and makes no commitment to update the information contained herein. Lontium reserves the right to change or discontinue this document and the products it describes at any time, without notice. Other than as set forth in a separate, signed, written agreement, Lontium grants the user of this document no right, title or interest in the document, the information it contains or the intellectual property it embodies.

**Trademarks**

Lontium™ 龙迅™ and ClearEdge™ is a registered trademark of Lontium Semiconductor. All other brand names, product names, trademarks, and registered trademarks contained herein are the property of their respective owners.

**Visit our corporate web page at: [www.lontiumsemi.com](http://www.lontiumsemi.com)**

**Technical support: [support@lontium.com](mailto:support@lontium.com)**

**Sales: [sales@lontium.com](mailto:sales@lontium.com)**