

PNP Low-Saturation Transistor

NZT660, NZT660A

Description

These devices are designed with high-current gain and low saturation voltage with collector currents up to 3 A continuous.

ABSOLUTE MAXIMUM RATINGS

($T_A = 25\text{ }^\circ\text{C}$ unless otherwise noted.) (Notes 1, 2)

Symbol	Parameter	Value	Unit
V_{CEO}	Collector-Emitter Voltage	-60	V
V_{CBO}	Collector-Base Voltage NZT660 NZT660A	-80 -60	V
V_{EBO}	Emitter-Base Voltage	-5	V
I_C	Collector Current – Continuous	-3	A
T_J, T_{STG}	Operating and Storage Junction Temperature Range	-55 to +150	$^\circ\text{C}$

Stresses exceeding those listed in the Maximum Ratings table may damage the device. If any of these limits are exceeded, device functionality should not be assumed, damage may occur and reliability may be affected.

1. These ratings are based on a maximum junction temperature of $150\text{ }^\circ\text{C}$.
2. These are steady limits. **onsemi** should be consulted on application involving pulsed or low-duty-cycle operations.

THERMAL CHARACTERISTICS

($T_A = 25\text{ }^\circ\text{C}$ unless otherwise noted.) (Note 3)

Symbol	Parameter	Max	Unit
P_D	Total Device Dissipation	2	W
$R_{\theta JA}$	Thermal Resistance, Junction to Ambient	62.5	$^\circ\text{C}/\text{W}$

3. PCB size: FR-4, 76 mm × 114 mm × 1.57 mm (3.0 inch × 4.5 inch × 0.062 inch) with minimum land pattern size.

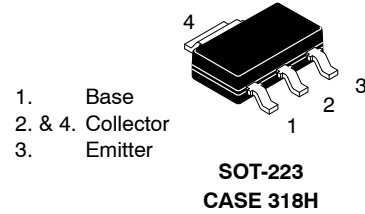

MARKING DIAGRAM

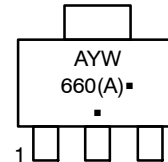

- A = Assembly Location
- Y = Year
- W = Work Week
- 660(A) = Specific Device Code
- = Pb-Free Package

(Note: Microdot may be in either location)

ORDERING INFORMATION

Device	Package	Shipping [†]
NZT660	SOT-223 (Pb-Free)	4,000 / Tape & Reel
NZT660A	SOT-223 (Pb-Free)	4,000 / Tape & Reel

[†] For information on tape and reel specifications, including part orientation and tape sizes, please refer to our Tape and Reel Packaging Specification Brochure, [BRD8011/D](#).

NZT660, NZT660A

ELECTRICAL CHARACTERISTICS ($T_C = 25\text{ }^\circ\text{C}$ unless otherwise noted.)

Symbol	Parameter	Test Conditions	Min	Max	Unit	
BV_{CEO}	Collector-Emitter Breakdown Voltage	$I_C = -10\text{ mA}$	-60	-	V	
BV_{CBO}	Collector-Base Breakdown Voltage	$I_C = -100\text{ }\mu\text{A}$	NZT660	-80	-	V
			NZT660A	-60	-	
BV_{EBO}	Emitter-Base Breakdown Voltage	$I_E = -100\text{ }\mu\text{A}$	-5	-	V	
I_{CBO}	Collector-Base Cut-Off Current	$V_{CB} = -30\text{ V}$	-	-100	nA	
		$V_{CB} = -30\text{ V}, T_A = 100\text{ }^\circ\text{C}$	-	-10	μA	
I_{EBO}	Emitter-Base Cut-Off Current	$V_{EB} = -4\text{ V}$	-	-100	nA	
h_{FE}	DC Current Gain (Note 4)	$I_C = -100\text{ mA}, V_{CE} = -2\text{ V}$	70	-		
		$I_C = -500\text{ mA}, V_{CE} = -2\text{ V}$	NZT660	100		300
			NZT660A	250		550
		$I_C = -1\text{ A}, V_{CE} = -2\text{ V}$	80	-		
$V_{CE(sat)}$	Collector-Emitter Saturation Voltage (Note 4)	$I_C = -1\text{ A}, I_B = -100\text{ mV}$	-	-300	mV	
		$I_C = -3\text{ A}, I_B = -300\text{ mV}$	NZT660	-		-550
			NZT660A	-		-500
$V_{BE(sat)}$	Base-Emitter Saturation Voltage (Note 4)	$I_C = -1\text{ A}, I_B = -100\text{ mV}$	-	-1.25	V	
$V_{BE(on)}$	Base-Emitter On Voltage (Note 4)	$I_C = -1\text{ A}, V_{CE} = -2\text{ V}$	-	-1	V	
C_{ob}	Output Capacitance	$V_{CB} = -10\text{ V}, I_E = 0, f = 1\text{ MHz}$	-	45	pF	
f_T	Transition Frequency	$I_C = -100\text{ mA}, V_{CE} = -5\text{ V}, f = 100\text{ MHz}$	75	-	MHz	

Product parametric performance is indicated in the Electrical Characteristics for the listed test conditions, unless otherwise noted. Product performance may not be indicated by the Electrical Characteristics if operated under different conditions.

4. Pulse test: pulse width $\leq 300\text{ }\mu\text{s}$, duty cycle $\leq 2.0\%$.

TYPICAL PERFORMANCE CHARACTERISTICS

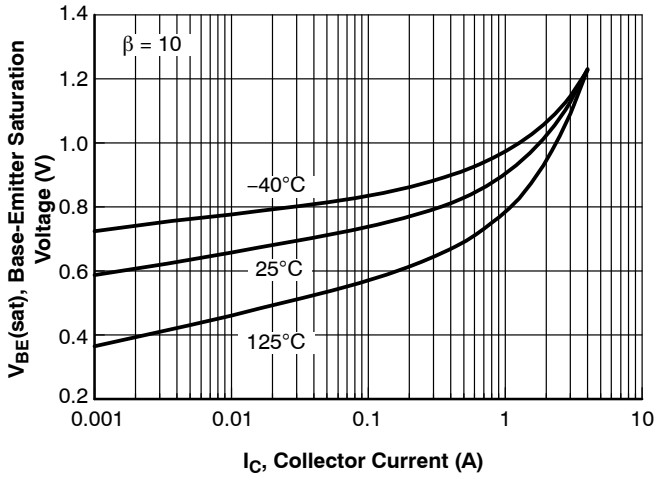

Figure 1. Base-Emitter Saturation Voltage vs. Collector Current

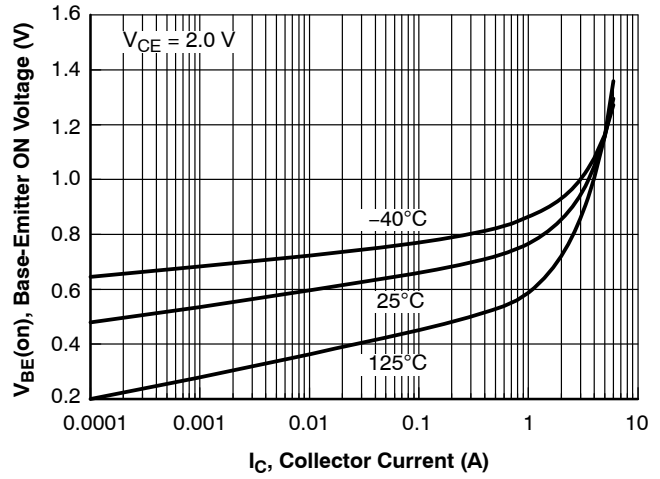

Figure 2. Base-Emitter On Voltage vs. Collector Current

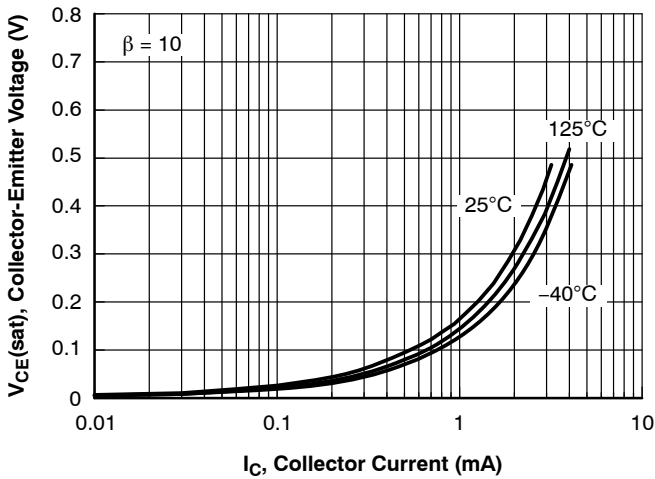

Figure 3. Collector-Emitter Saturation Voltage vs. Collector Current

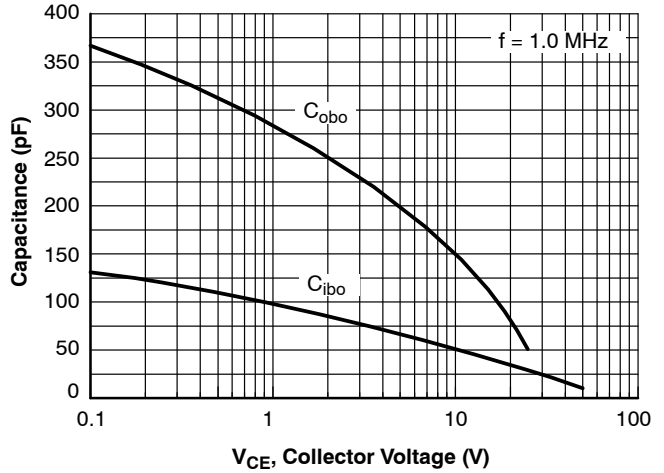

Figure 4. Input/Output Capacitance vs. Reverse Bias Voltage

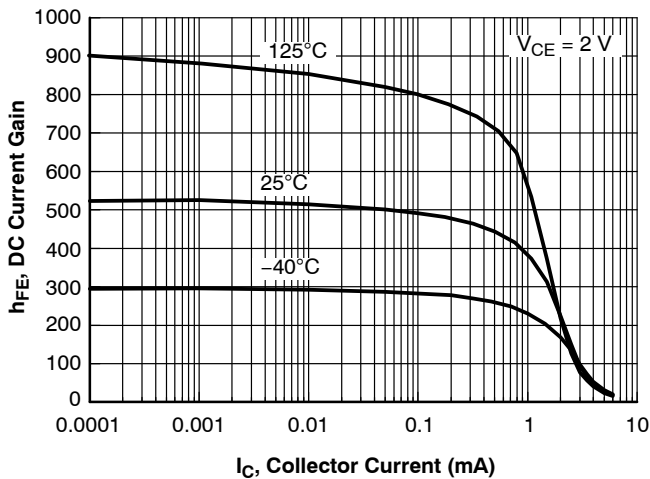
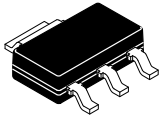

Figure 5. Current Gain vs. Collector Current

NZT660, NZT660A

REVISION HISTORY

Revision	Description of Changes	Date
3	Revision to correct marking diagram information only.	06/23/2025



SCALE 2:1

SOT-223
CASE 318H
ISSUE B

DATE 13 MAY 2020

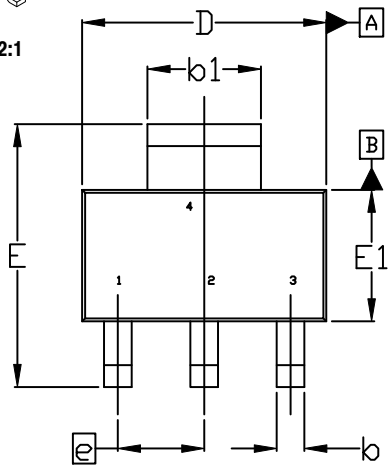

TOP VIEW

$\phi 0.10 \text{ (M) C A B}$

NOTE 7

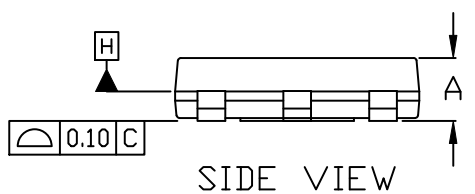

SIDE VIEW

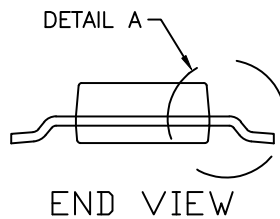

END VIEW

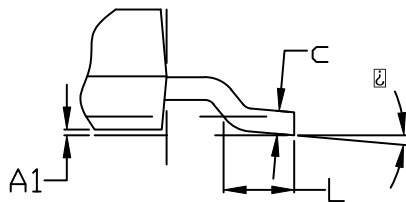

DETAIL A

NOTES:

1. DIMENSIONING AND TOLERANCING PER ASME Y14.5M, 2009.
2. CONTROLLING DIMENSION: MILLIMETERS
3. DIMENSIONS D & E1 ARE DETERMINED AT DATUM H. DIMENSIONS DO NOT INCLUDE MOLD FLASH, PROTRUSIONS OR GATE BURRS. SHALL NOT EXCEED 0.23mm PER SIDE.
4. LEAD DIMENSIONS b AND b1 DO NOT INCLUDE DAMBAR PROTRUSION. ALLOWABLE DAMBAR PROTRUSION IS 0.08mm PER SIDE.
5. DATUMS A AND B ARE DETERMINED AT DATUM H.
6. A1 IS DEFINED AS THE VERTICAL DISTANCE FROM THE SEATING PLANE TO THE LOWEST POINT OF THE PACKAGE BODY.
7. POSITIONAL TOLERANCE APPLIES TO DIMENSIONS b AND b1.

DIM	MILLIMETERS		
	MIN.	NOM.	MAX.
A	---	---	1.80
A1	0.02	0.06	0.11
b	0.60	0.74	0.88
b1	2.90	3.00	3.10
c	0.24	---	0.35
D	6.30	6.50	6.70
E	6.70	7.00	7.30
E1	3.30	3.50	3.70
e	2.30 BSC		
L	0.25	---	---
\square	0°	---	10°

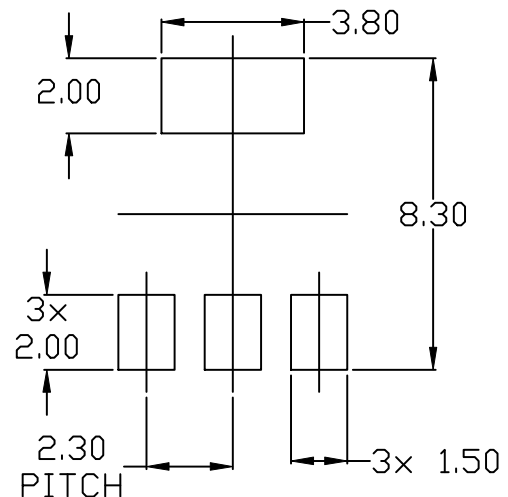

RECOMMENDED MOUNTING FOOTPRINT

* For additional information on our Pb-Free strategy and soldering details, please download the DN Semiconductor Soldering and Mounting Techniques Reference Manual, SLDERRM/D.

GENERIC MARKING DIAGRAM*

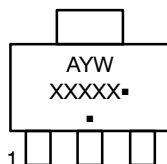

- A = Assembly Location
- Y = Year
- W = Work Week
- XXXXX = Specific Device Code
- = Pb-Free Package

(Note: Microdot may be in either location)

*This information is generic. Please refer to device data sheet for actual part marking. Pb-Free indicator, "G" or microdot "▪", may or may not be present. Some products may not follow the Generic Marking.

DOCUMENT NUMBER:	98ASH70634A	Electronic versions are uncontrolled except when accessed directly from the Document Repository. Printed versions are uncontrolled except when stamped "CONTROLLED COPY" in red.
DESCRIPTION:	SOT-223	PAGE 1 OF 1

onsemi and ONSEMI are trademarks of Semiconductor Components Industries, LLC dba onsemi or its subsidiaries in the United States and/or other countries. onsemi reserves the right to make changes without further notice to any products herein. onsemi makes no warranty, representation or guarantee regarding the suitability of its products for any particular purpose, nor does onsemi assume any liability arising out of the application or use of any product or circuit, and specifically disclaims any and all liability, including without limitation special, consequential or incidental damages. onsemi does not convey any license under its patent rights nor the rights of others.

onsemi, **Onsemi**, and other names, marks, and brands are registered and/or common law trademarks of Semiconductor Components Industries, LLC dba "**onsemi**" or its affiliates and/or subsidiaries in the United States and/or other countries. **onsemi** owns the rights to a number of patents, trademarks, copyrights, trade secrets, and other intellectual property. A listing of **onsemi**'s product/patent coverage may be accessed at www.onsemi.com/site/pdf/Patent-Marking.pdf. **onsemi** reserves the right to make changes at any time to any products or information herein, without notice. The information herein is provided "as-is" and **onsemi** makes no warranty, representation or guarantee regarding the accuracy of the information, product features, availability, functionality, or suitability of its products for any particular purpose, nor does **onsemi** assume any liability arising out of the application or use of any product or circuit, and specifically disclaims any and all liability, including without limitation special, consequential or incidental damages. Buyer is responsible for its products and applications using **onsemi** products, including compliance with all laws, regulations and safety requirements or standards, regardless of any support or applications information provided by **onsemi**. "Typical" parameters which may be provided in **onsemi** data sheets and/or specifications can and do vary in different applications and actual performance may vary over time. All operating parameters, including "Typicals" must be validated for each customer application by customer's technical experts. **onsemi** does not convey any license under any of its intellectual property rights nor the rights of others. **onsemi** products are not designed, intended, or authorized for use as a critical component in life support systems or any FDA Class 3 medical devices or medical devices with a same or similar classification in a foreign jurisdiction or any devices intended for implantation in the human body. Should Buyer purchase or use **onsemi** products for any such unintended or unauthorized application, Buyer shall indemnify and hold **onsemi** and its officers, employees, subsidiaries, affiliates, and distributors harmless against all claims, costs, damages, and expenses, and reasonable attorney fees arising out of, directly or indirectly, any claim of personal injury or death associated with such unintended or unauthorized use, even if such claim alleges that **onsemi** was negligent regarding the design or manufacture of the part. **onsemi** is an Equal Opportunity/Affirmative Action Employer. This literature is subject to all applicable copyright laws and is not for resale in any manner.

ADDITIONAL INFORMATION

TECHNICAL PUBLICATIONS:

Technical Library: www.onsemi.com/design/resources/technical-documentation
onsemi Website: www.onsemi.com

ONLINE SUPPORT: www.onsemi.com/support

For additional information, please contact your local Sales Representative at www.onsemi.com/support/sales