



深圳市福瑞达显示技术有限公司  
SHENZHEN FRIDA LCD CO.,LTD

Doc No: FRD144P27010-A

REV: A

PAGE: 1/15

SPEC TITLE  
DOCUMENT CONTROL SPECIFICATION

EFFECTIVE DATE: 2018-09-20

# PRODUCT SPECIFICATION

## TFT-LCD MODULE

**Model No: FRD144P27010-A**

For Customer's Acceptance	
Approved by	Comment

	Signature	Date
Prepared by	许三 2018.9.20 深援武	2018.9.20
Checked by		2018.9.21
Approved by	胡凯	2018.9.25

深圳市福瑞达显示技术有限公司

地址: 深圳市光明新区公明田寮第二工业区田荣路 68 号

Add: The 68th, Tianrong Road, Tianliao Community, Gongming Town, Guangming new district, shenzhen.

电话(Tel): (0755)33563741 (0755)33563743

传真(Fax): (0755)29351371

网址(Web): www.fridalcd.com



## Contents

No.	ITEM
<b>1</b>	<b>Document Revision History</b>
<b>2</b>	<b>General Description</b>
<b>3</b>	<b>Outline Dimension</b>
<b>4</b>	<b>Interface Specification</b>
<b>5</b>	<b>Absolute Maximum Ratings</b>
<b>6</b>	<b>Electrical Specifications</b>
<b>7</b>	<b>Timing Characteristics</b>
<b>8</b>	<b>Power Supply Configuration</b>
<b>9</b>	<b>Optical Specification</b>
<b>10</b>	<b>Reliability Test Items</b>
<b>11</b>	<b>Precautions</b>



### 1. Document Revision History :

DOCUMENT REVISION	DATE	DESCRIPTION	PREPARED BY
A	2018-09-20	First Release.	



## 2. General Description

No	Item	Specification	Remark
1	Screen Size	1.44 inch	
2	Display Mode	Normally White	
3	Resolution	128 × RGB × 128	
4	Active Area	25.50*26.50	mm
5	Outline Dimension	29.80*34.60*2.35	mm
6	Viewing Direction	12 o' clock	
7	Driver IC	ST7735S	
8	Interface	MCU	
9	Back Light	White Led*1	
10	Touch Panel	-	

### 3. Outline Dimension

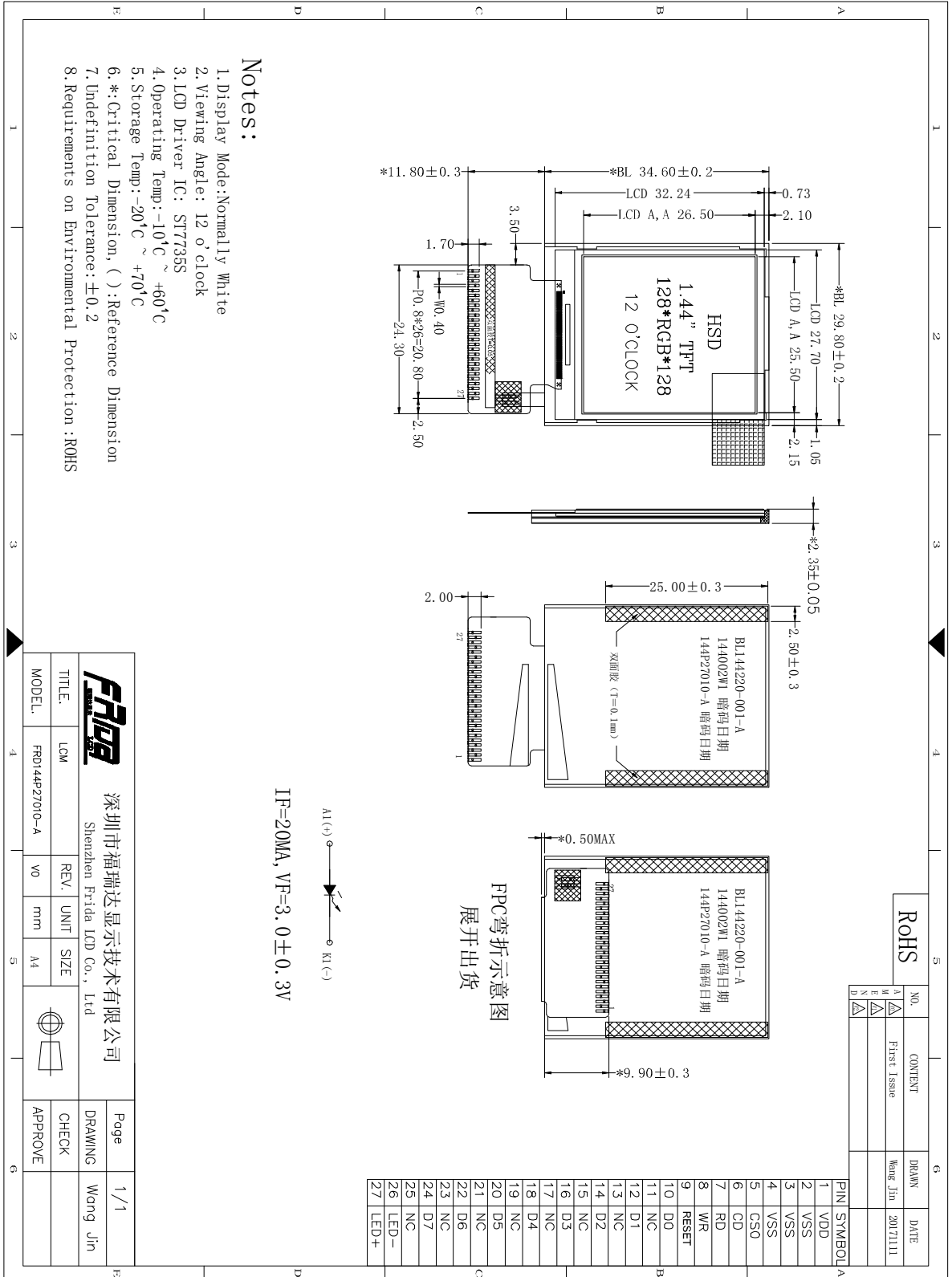



## 4. Interface Specification

Pin No	Symbol	Description	Note
1	VDD	Power Supply For LCD	
2~4	VSS	Ground.	
5	CS0	Chip selection signal.	
6	CD	Data / Command Selection pin.	
7	RD	Read strobe signal.	
8	WR	Write strobe signal.	
9	RESET	Reset Signal input pin.	
10	D0	MCU parallel interface data input	
11	NC	No Connection.	
12	D1	MCU parallel interface data input	
13	NC	No Connection.	
14	D2	MCU parallel interface data input	
15	NC	No Connection.	
16	D3	MCU parallel interface data input	
17	NC	No Connection.	
18	D4	MCU parallel interface data input	
19	NC	No Connection.	
20	D5	MCU parallel interface data input	
21	NC	No Connection.	
22	D6	MCU parallel interface data input	
23	NC	No Connection.	
24	D7	MCU parallel interface data input	
25	NC	No Connection.	
26	LED-	Power Supply For LED Backlight Cathode Input.	
27	LED+	Power Supply For LED Backlight Anode Input.	



## 5. Absolute Maximum Ratings

### Electrical Maximum Ratings – for IC Only

Parameter	Symbol	Min.	Max.	Unit	Note
Power supply voltage (VDD)	VDD	-0.3	+4.8	V	1

Note:

- 1.VDD, GND must be maintained.
- 2.The modules may be destroyed if they are used beyond the absolute maximum ratings.

## 6. Electrical Specifications

At Ta = 25 °C, VDD = 2.5V to 4.8V, GND=0V.

Parameter	Symbol	Conditions	Min.	Typ.	Max.	Unit
Supply voltage (analog)	VDD-GND	-	2.5	2.75	4.8	V
Supply current (Logic & LCD)	VDD		-	-	-	mA
Supply voltage of white LED backlight	VLED	Forward current =20mA Number of LED = 1	2.7	3.0	3.3	V

## 7. Timing Characteristics

### 8.1 Parallel Interface Characteristics: 18, 16, 9 or 8-bit Bus (8080 Series MCU Interface)

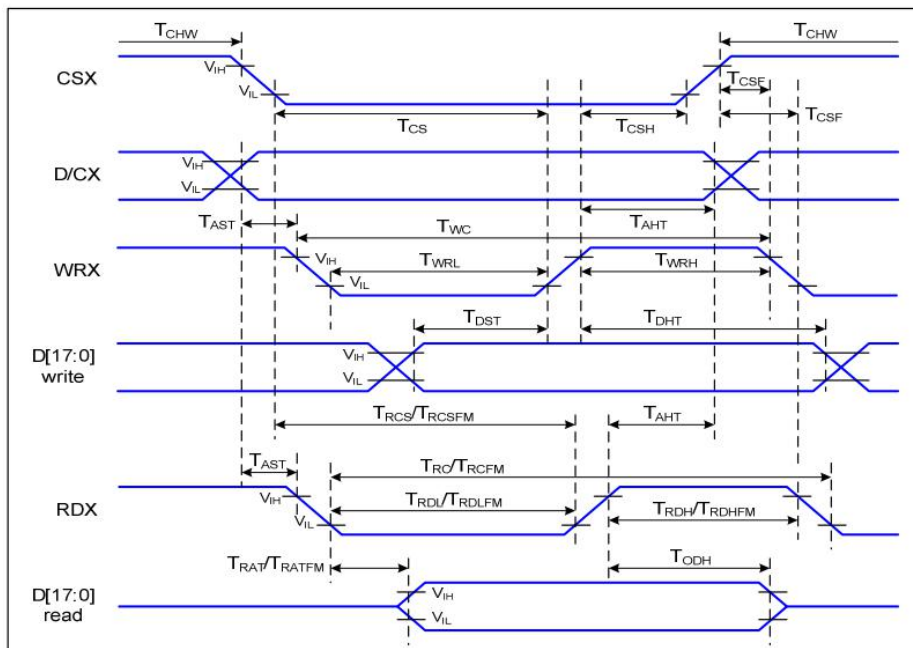

Figure 1 Parallel Interface Timing Characteristics (8080 Series MCU Interface)





Ta=25 ℃, VDDI=1.65~3.7V, VDD=2.5~4.8V

Signal	Symbol	Parameter	Min	Max	Unit	Description
D/CX	TAST	Address Setup Ttime	0		ns	-
	TAHT	Address Hold Time (Write/Read)	10		ns	
CSX	TCHW	Chip Select "H" Pulse Width	0		ns	-
	TCS	Chip Select Setup Time (Write)	15		ns	
	TRCS	Chip Select Setup Time (Read ID)	45		ns	
	TRCSFM	Chip Select Setup time (Read FM)	355		ns	
	TCSF	Chip Select Wait Time (Write/Read)	10		ns	
	TCSH	Chip Select Hold Time	10		ns	
WRX	TWC	Write Cycle	66		ns	
	TWRH	Control Pulse "H" Duration	15		ns	
	TWRL	Control Pulse "L" Duration	15		ns	
RDX (ID)	TRC	Read Cycle (ID)	160		ns	When Read ID Data
	TRDH	Control Pulse "H" Duration (ID)	90		ns	
	TRDL	Control Pulse "L" Duration (ID)	45		ns	

## 8.Power Supply Configuration

### 9.13 Power ON/OFF Sequence

VDDI and VDD can be applied in any order

VDD and VDDI can be powered down in any order

During power off, if LCD is in the Sleep Out mode, VDD and VDDI must be powered down minimum 120msec after RESX has been released.

During power off, if LCD is in the Sleep In mode, VDDI or VDD can be powered down minimum 0msec after RESX has been released.

CSX can be applied at any timing or can be permanently grounded. RESX has priority over CSX.

*Note 1: There will be no damage to the display module if the power sequences are not met.*

*Note 2: There will be no abnormal visible effects on the display panel during the Power On/Off Sequences.*

*Note 3: There will be no abnormal visible effects on the display between end of Power On Sequence and before receiving Sleep Out command. Also between receiving Sleep In command and Power Off Sequence.*

*Note 4: If RESX line is not held stable by host during Power On Sequence as defined in the sequence below, then it will be necessary to apply a Hardware Reset (RESX) after Host Power On Sequence is complete to ensure correct operation. Otherwise function is not guaranteed.*

The power on/off sequence is illustrated below

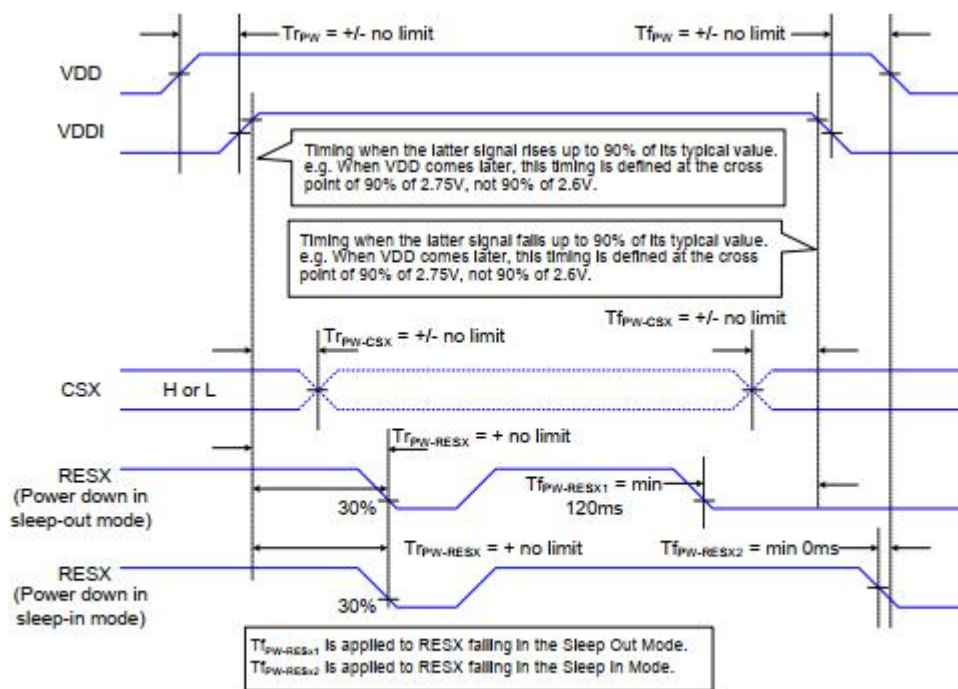

## 9. Optical Specification



Item 项目	Symbol 符号	Condition 条件	Min 最小值	Typ 典型值	Max 最大值	Unit 单位	Note 备注
Response time 响应时间	Tr+Tf	$\Theta=0^{\circ}$ $\emptyset=0^{\circ}$ Ta=25°C	-	16	32	ms	1
Contrast ratio 对比度	Cr		400	500	-	-	2
Color gamut 饱和度	S(%)		-	53	-	%	-
Luminance uniformity 均匀度	$\delta$ WHITE		80	-	-	%	3
Viewing angle range 视角范围	$\Theta_{x+}$	CR $\geq$ 10	-	45	-	deg	4
	$\Theta_{x-}$		-	45	-	deg	
	$\Theta_{y+}$		-	45	-	deg	
	$\Theta_{y-}$		-	20	-	deg	
LCM Luminance LCM 亮度	Lv	$\Theta=0^{\circ}$ $\emptyset=0^{\circ}$ Ta=25°C	-	150	-	Cd/m <sup>2</sup>	5
CIE (X,Y) Chromaticity 色度坐标	White(X)		0.25	0.27	0.29	-	6
	White(Y)		0.27	0.30	0.33	-	

Note1. Response time is the time required for the display to transition from White to black(Rise Time,Tr)and from black to white(Decay Time,Tf).For additional information see FIG1...

Note2.contrast Ratio(CR) is defined mathematically by the following formula ,For more information see FIG2.

Contrast Ratio(CR)=Average Surface Luminance with all white pixels/ Average Surface Luminance with all black pixels

Note3.The uniformity in surface luminance(WHITE) is determined by measuring luminance at each test position,and then dividing the maximum luminance of all white pixels by minimum luminance of all white pixels,For more information seeFIG2.

WHITE=Minimum Surface Luminance with all white pixels(P1,P2,.....)/Maximum Surface Luminance with all white pixels(P1,P2,.....)

Note4.Viewing angle is the angel at which contrast ratio is greater than a specific value.For

TET module,the specific value of contrast ratio is 10.For monochrome and color stn module,the specific value of contrast ratio is2.The angles are determined for the horizontal or x axis and the vertical or y axis with respect to the z axis which is normal to the LCD surface.For more information see FIG3

Note5. Surface luminance is the LCD surface luminance with all white pixels,For more information see FIG2.

LV=Average Surface Luminance with all white pixels(P1,P2,.....)

Note6.CIE(X,Y)chromaticity is the Center point value.For more information see FIG2.

Note7.For Viewing angle and response time testing,the testing date is base on Autronic-Melchers' s ConScope.Series instruments.For contrast ratio,Surface Luminance,Luminance uniformity and CIE,the testing date is base on CS-2000 photo detector.

Note8.For TN type TFT transmissive module,Gray scale reverse occurs in the direction of panel viewing angle

FIG1. The definition of Response time

响应时间定义

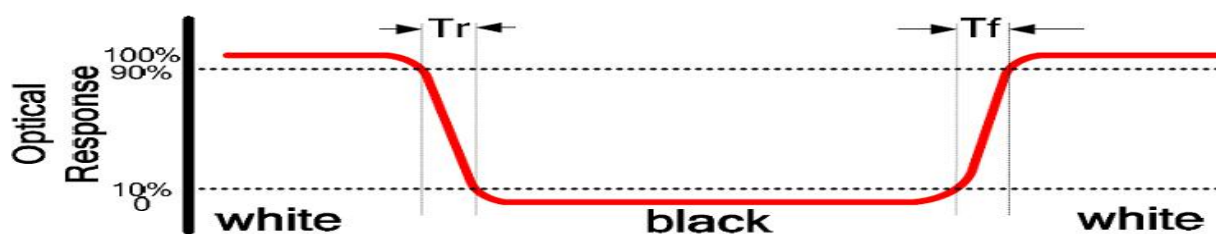

FIG2. Measuring method for Contrast ratio,surface luminance,Luminance

uniformity,CIE(X,Y)chromaticity.

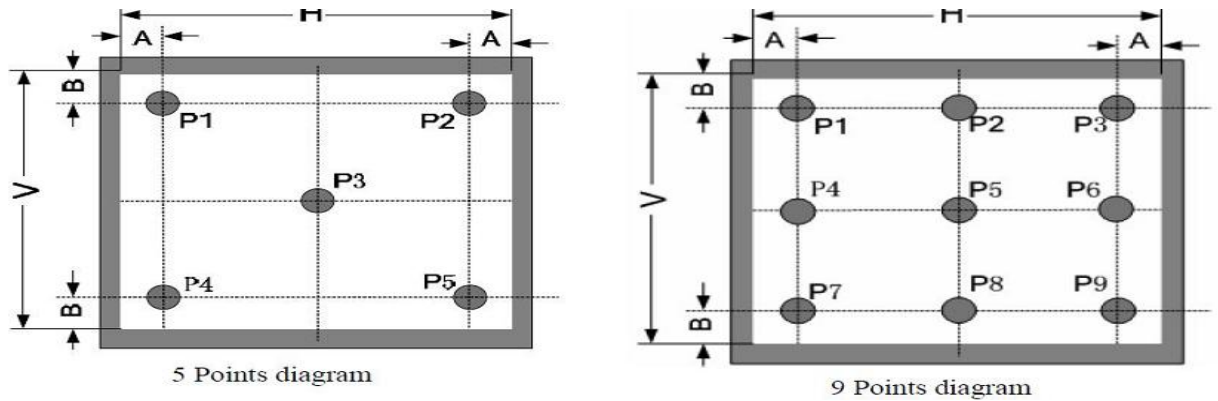
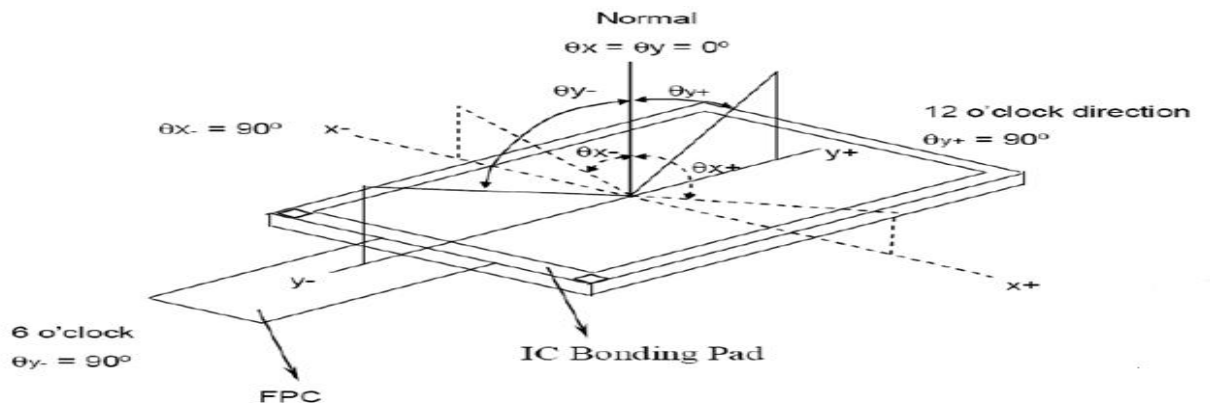

FIG3 The definition of viewing angle 视角定义





## 10. Reliability Test Items

Item	Test Condition	Criterion
High Temperature Storage	70 °C, 48 hrs	Note1,Note2
Low Temperature Storage	-20 °C, 48 hrs	
High Temp. & High Humidity Storage	40 °C, 80% RH, 48hrs	
Thermal Shock (Static)	-20°C, 30 min /70°C, 30 min, 20 cycles	
High Temperature Operation	60 °C, 48 hrs	
Low temperature Operation	-10 °C, 48 hrs	

Note1: Evaluation should be tested after storage at room temperature for two hours.

Note2:

Pass: Normal display image no line defect.

Fail: No display image, or line defects.

Partial transformation of the module parts should be ignored.

## 11. Precautions

Please pay attentions to the followings as using the LCD module.

### Handling

- (a) Do not apply strong mechanical stress like drop, shock or any force to LCD module. It may cause improper operation, even damage.
- (b) Because the polarizer is very fragile and easy to be damaged, do not hit, press or rub the display surface with hard materials.
- (c) Do not put heavy or hard material on the display surface, and do not stack LCD modules.
- (d) If the display surface is dirty, please wipe the surface softly with cotton swab or clean cloth.



- (e) Avoid using Ketone type materials (e.g. Acetone), Toluene, Ethyl acid or Methyl chloride to clean the display surface. It might damage the touch panel surface permanently. The recommended solvents are water and Isopropyl alcohol.
- (f) Wipe off water droplets or oil immediately.
- (g) Protect the LCD module from ESD. It will damage the LSI and the electronic circuit.
- (h) Do not touch the output pins directly with bare hands.
- (i) Do not disassemble the LCD module.
- (j) Do not lift the FPC of Touch Panel.

### **Storage**

- (a) Do not leave the LCD modules in high temperature, especially in high humidity for a long time.
- (b) Do not expose the LCD modules to sunlight directly.
- (c) The liquid crystal is deteriorated by ultraviolet. Do not leave it in strong ultraviolet ray for a long time.
- (d) Avoid condensation of water. It may cause improper operation.
- (e) Please stack only up to the number stated on carton box for storage and transportation. Excessive weight will cause deformation and damage of carton box.

### **Operation**

- (a) When mounting or dismounting the LCD modules, turn the power off.
- (b) Protect the LCD modules from electric shock.
- (c) The Driver IC control algorithms stated above should always obeyed to avoid damaging the LSI and electronic circuit.
- (d) Be careful to avoid mixing up the polarity of power supply for backlight.
- (e) Absolute maximum rating specified above has to be always kept in any case. Exceeding it may cause non-recoverable damage of electronic components or, nevertheless, burning.
- (f) When a static image is displayed for a long time, remnant image is likely to occur.
- (g) Be sure to avoid bending the FPC to an acute shape, it might break FPC.
- (h) Most of the touch screens have air vent to equalize the inside air pressure to the outside one. The air vent must be open and liquid contact must be avoided as the liquid may be

absorbed if the liquid is accumulated near the air vent.

- (i) For the fragility of ITO film, it should avoid to use too tapering pen as the input material.

### Touch Panel Mounting Notes

- (a) If a cushion is used between bezel/housing and film must be choose as free as enough to absorb the expansion and contraction to avoid the distortion of film.
- (b) The cushion must be placed out of the Viewing Area.
- (c) Bezel/Housing edge must be posited between Key Area and Viewing Area. The edge enters the Key Area may cause unexpected input if the gap is too narrow or foreign particles like dusts exist between Bezel/Housing and ITO film.
- (d) Mounting example:

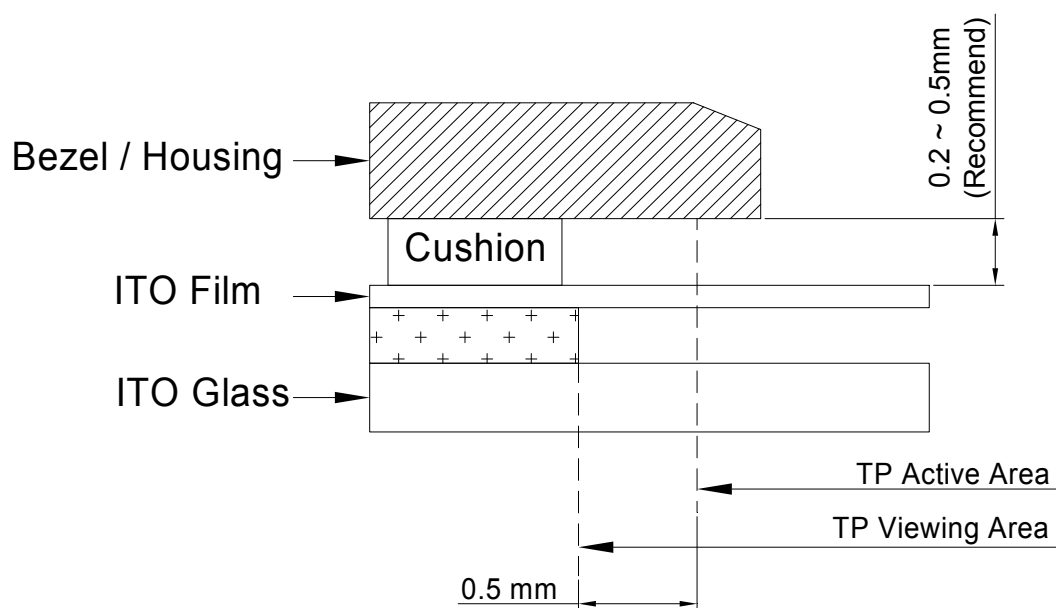

The corner part has conductivity. Do not touch any metal part after mounting.

### Others

- a) If the liquid crystal leaks from the panel, it should be kept away from the eyes or mouth.
- b) For the fragility of polarizer, it is recommended to attach a transparent protective plate over the display surface.
- c) It is recommended to peel off the protection film on the polarizer slowly so that the electrostatic charge can be minimized.