

# 产品规格书

## SPECIFICATION

客户名称:

Client Name

产品名称:

EMC5050 方杯 4.5W 综合版

Client P/N

产品型号:

LY-XE200304WH36B-XX-XX-FS

Product P/N

日期:

2022-11-30

Sending Date

核准 Approval	确认 Audit	制作 Confirmation
	支柱	谢荣
版本/Version	A0	

- 注: 1.此规格书以中英文方式书写, 若有冲突以中文版文本为准。  
2.此规格书的最终解释权归由深圳市立洋光电子股份有限公司。

 **LM-80 ISO9001:2015**



## Model Explanation

### 型号介绍

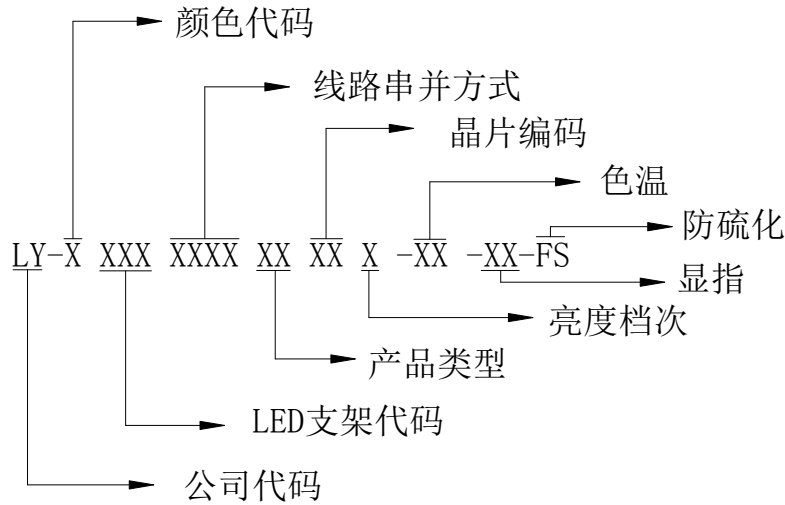

## ■Features

### 特征

- ◆ Series Parallel Combination Circuit/串并组合
- ◆ Low Thermal Resistance/低热阻
- ◆ Super Energy Efficiency/高光效
- ◆ Half Angle ( $2\Theta_{1/2}$ ): 120°/半功率角度: 120°
- ◆ RoHS Compliant.

## ■Applications

### 应用

- ◆ General Lighting/普通照明
- ◆ Advertisement/广告灯
- ◆ Architectural Lighting/建筑照明
- ◆ Street Lamps/路灯
- ◆ Other Lighting/其它照明

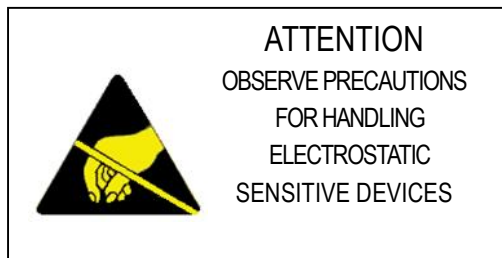

## Package Dimensions

外观尺寸 (标识点为正极)

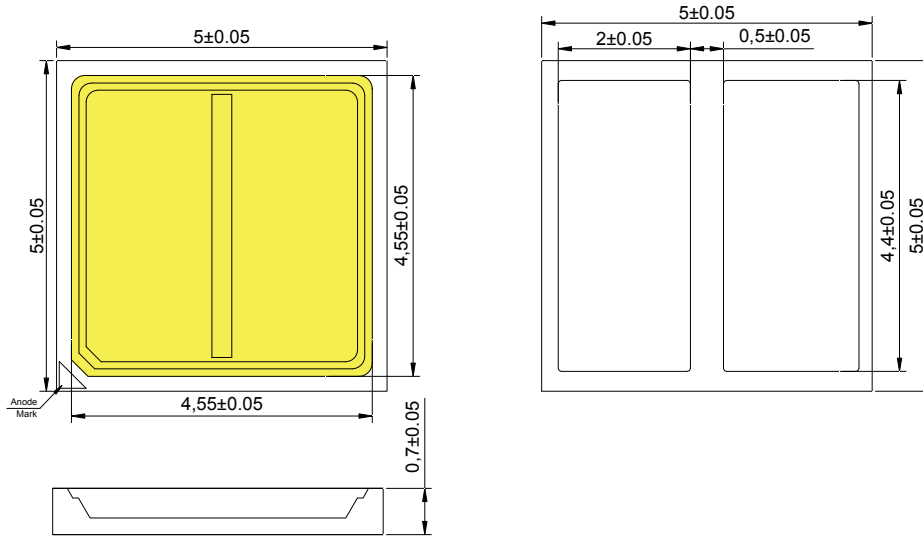

PCB 焊盘尺寸:

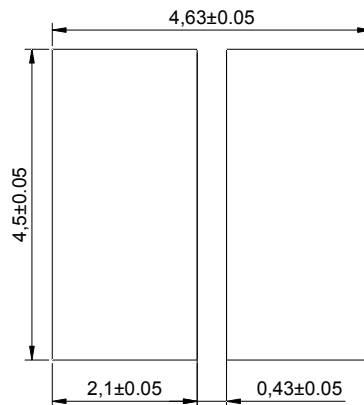

Equivalent circuit diagram

等效电路图: 3 串 4 并

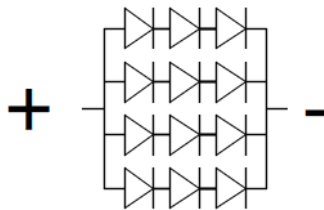

## Notes:

1. All dimensions are in millimeters.  
(所有尺寸以毫米为单位)
2. Tolerance is  $\pm 0.25$  unless otherwise noted  
(未标注公差为:  $\pm 0.25$ )



■ **Absolute Maximum Rating(At TA=25°C)**  
(极限参数)

Parameter 参数	Symbol 符号	Value 数值	Units 单位
Power Dissipation 输入功率范围	P <sub>I</sub>	5	W
Operating current range 正向电流范围	I <sub>F</sub>	550	mA
Junction Temperature 结点温度	T <sub>J</sub>	120	°C
Operating Temperature Range 工作温度	T <sub>OPR</sub>	-20°C To +80°C	
Storage Temperature Range 储存温度	T <sub>stg</sub>	-40°C To +100°C	

■ **产品规格**

功率 (W)	发光 颜色	色温范围 (K)	产品型号	显色 指数 Ra.	Luminous Flux. 光通量 (LM)	电流 (mA)	电压 (V)
4.5	暖白光	2700K	LY-IE200304WH36B-27-70-FS	70	690-740	500	8.6-9.0
4.5	暖白光	3000K	LY-IE200304WH36B-30-70-FS	70	710-760	500	8.6-9.0
4.5	暖白光	3500K	LY-IE200304WH36B-35-70-FS	70	740-790	500	8.6-9.0
4.5	中性白光	4000K	LY-NE200304WH36B-40-70-FS	70	760-810	500	8.6-9.0
4.5	白光	5000K	LY-WE200304WH36B-50-70-FS	70	760-810	500	8.6-9.0
4.5	白光	5700K	LY-WE200304WH36B-57-70-FS	70	760-810	500	8.6-9.0
4.5	白光	6500K	LY-WE200304WH36B-65-70-FS	70	760-810	500	8.6-9.0



<b>Reliability</b>					
<b>TEST ITEMS AND RESULTS</b>					
Test	Reference Standard	Test Condition	Test Duration	Failure Criteria	Units Failed/Tested
Temperature Cycle	JEITA ED-4701 100 105	-40°C(30min)~25°C(5min)~ 80°C(30min)~25°C(5min)	100cycles	#1	0/10
High Temperature Storage	JEITA ED-4701 200 201	T <sub>A</sub> =100°C	1000hours	#1	0/10
Temperature Humidity Storage	JEITA ED-4701 100 103	T <sub>A</sub> =85°C RH=85%	1000hours	#1	0/10
Low Temperature Storage	JEITA ED-4701 200 202	T <sub>A</sub> =-40°C	1000hours	#1	0/10
Room Temperature Operating Life		T <sub>A</sub> =25°C, I <sub>F</sub> =500mA	1000hours	#1	0/10
High Temperature Operating Life		T <sub>A</sub> =90°C, I <sub>F</sub> =500mA	1000hours	#1	0/10
<b>(2)Failure Criteria</b>					
Criteria#	Items	Conditions	Failure Criteria		
#1	Forward Voltage(V <sub>F</sub> )	I <sub>F</sub> =500mA	>Initial value x 1.2		
	Luminous Flux(Φ <sub>v</sub> )	I <sub>F</sub> =500mA	<Initial value x 0.7		
U.S.L.:Upper Standard Level                      L.S.L.:Lower Standard Level					



**Color Code BIN:**

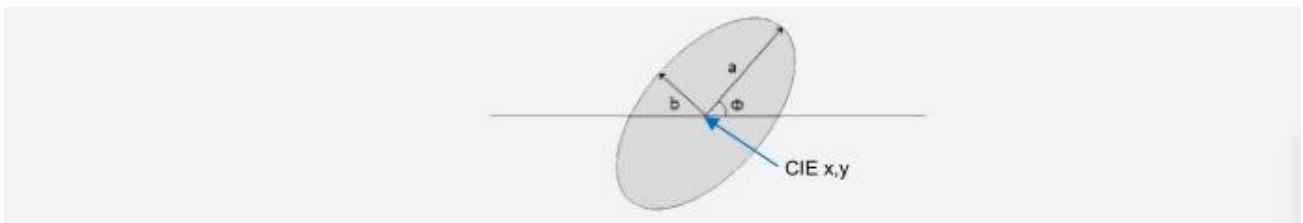
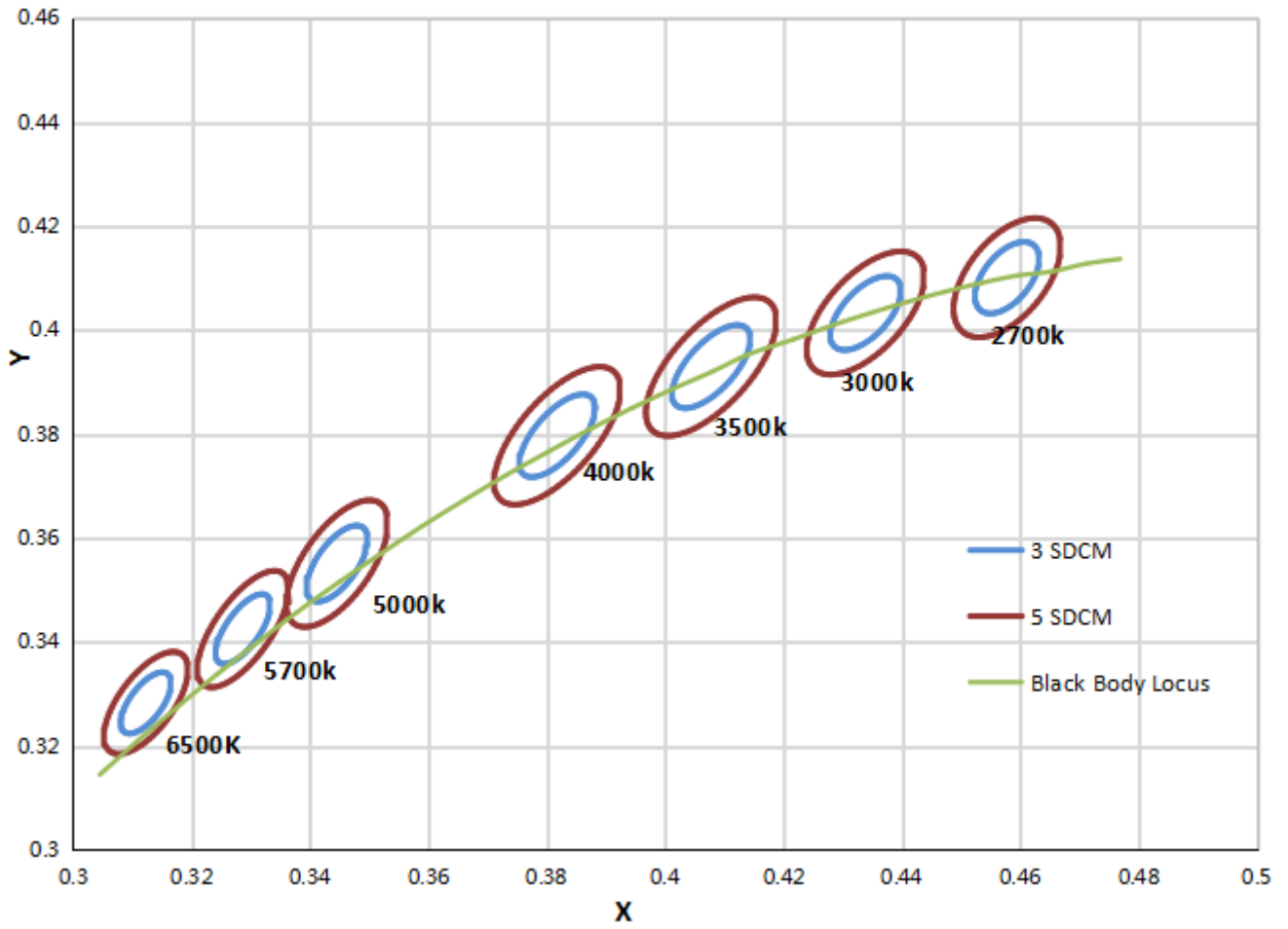

## Mac Adam Ellipse

Mac Adam Ellipse ( 2700K )						Mac Adam Ellipse ( 3000K )					
Step	CIE X	CIE Y	θ	a	b	Step	CIE X	CIE Y	θ	a	b
3-step	0.4578	0.4101	53.7	0.0081	0.0042	3-step	0.4338	0.403	53.22	0.0083	0.0041
5-step	0.4578	0.4101	53.7	0.0135	0.007	5-step	0.4338	0.403	53.22	0.0139	0.0068

Mac Adam Ellipse ( 3500K )						Mac Adam Ellipse ( 4000K )					
Step	CIE X	CIE Y	θ	a	b	Step	CIE X	CIE Y	θ	a	b
3-step	0.4073	0.3917	54	0.00927	0.00414	3-step	0.3818	0.3797	53.72	0.00939	0.00402
5-step	0.4073	0.3917	54	0.01545	0.0069	5-step	0.3818	0.3797	53.72	0.01565	0.0067

Mac Adam Ellipse ( 5000K )						Mac Adam Ellipse ( 5700K )					
Step	CIE X	CIE Y	θ	a	b	Step	CIE X	CIE Y	θ	a	b
3-step	0.3447	0.3553	59.62	0.0082	0.0035	3-step	0.3287	0.3417	59.09	0.00746	0.0032
5-step	0.3447	0.3553	59.62	0.0137	0.0059	5-step	0.3287	0.3417	59.09	0.01243	0.00533

Mac Adam Ellipse ( 6500K )											
Step	CIE X	CIE Y	θ	a	b						
3-step	0.3123	0.3282	58.57	0.00669	0.00285						
5-step	0.3123	0.3282	58.57	0.01115	0.00475						

Note:

maintains measurement tolerance of: Cx, Cy = ±0.005



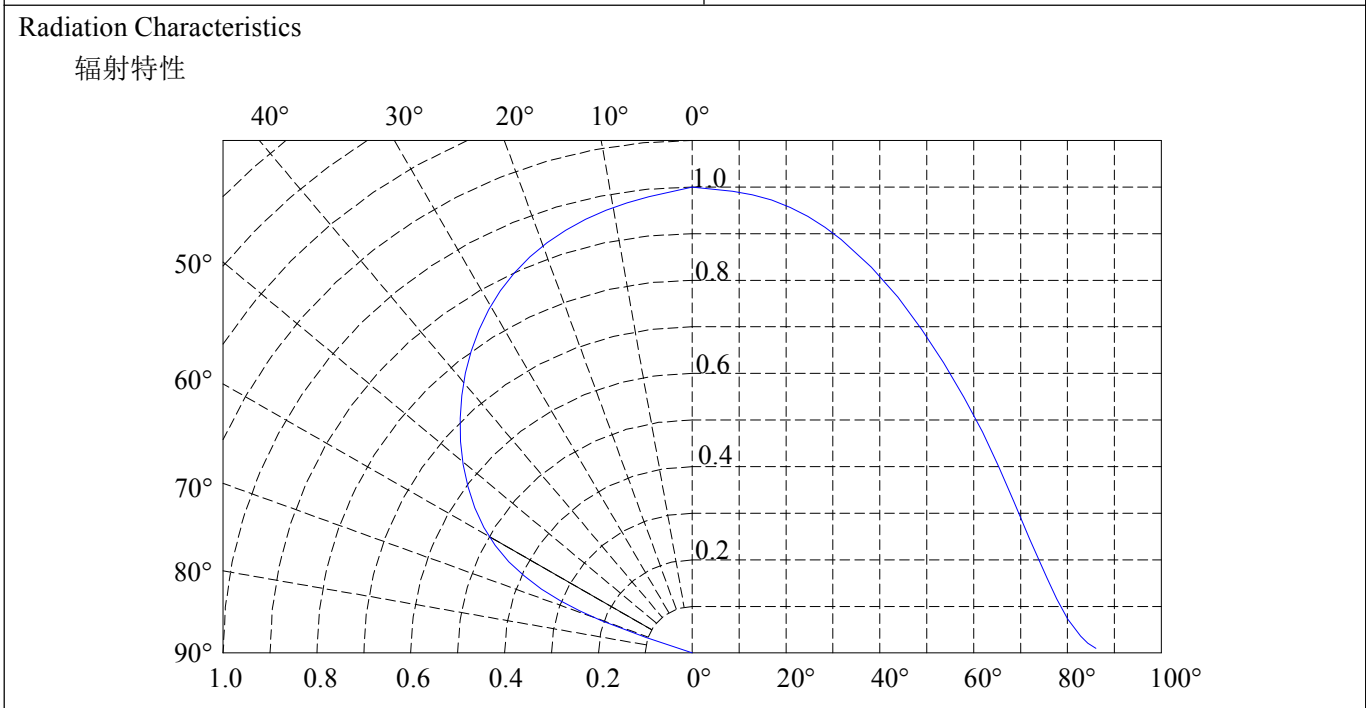
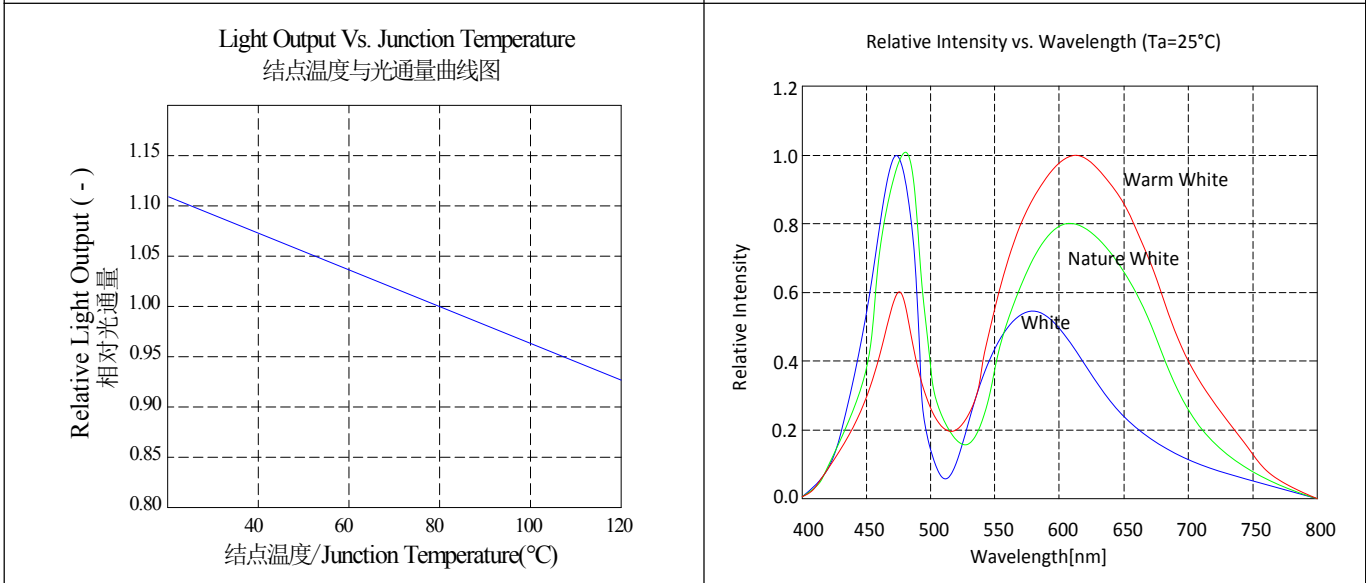
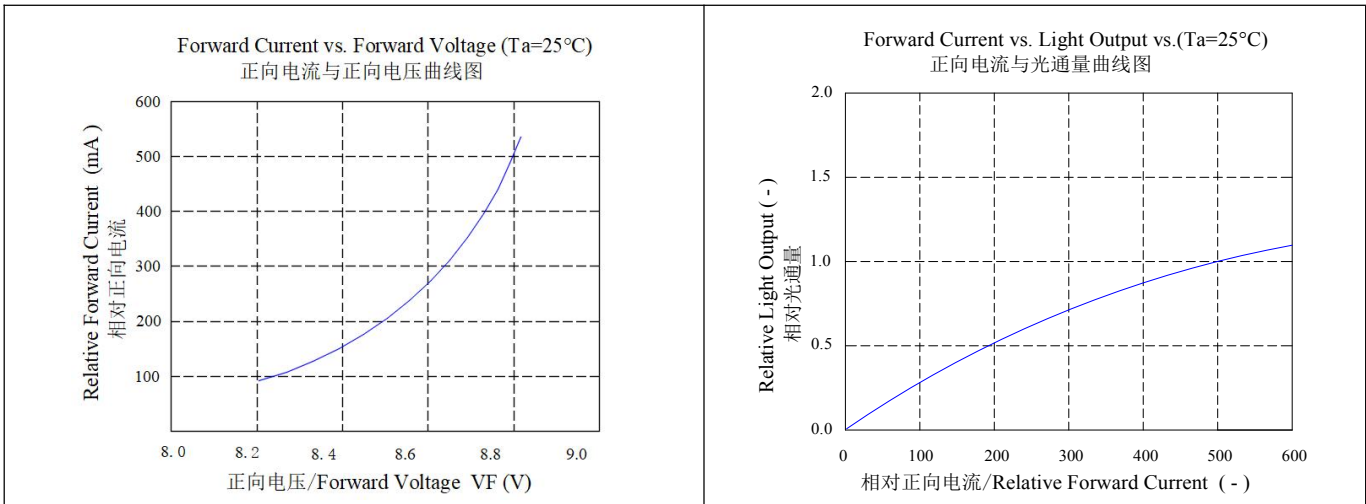



## 包装说明

### Label 标签

<b>P/N:</b> 产品型号	<div style="border: 1px solid black; padding: 10px; text-align: center;"> <p>深圳市立洋光电子有限公司</p> <p>P/N: _____</p> <p>VF: _____ IF: _____</p> <p>BIN Code/CCT: _____</p> <p>IV: _____ Q' TY: _____</p> <p>   *XXXXXXXXXXXX*</p> <p>ROHS</p> </div>
<b>VF:</b> 正向电压	
<b>IF:</b> 额定驱动电流	
<b>BIN Code/CCT:</b> 色区/色温	
<b>IV:</b> 流明等级	
<b>Q'TY:</b> 数量	

### 载带包装图

#### 产品（负极）朝载带圆孔

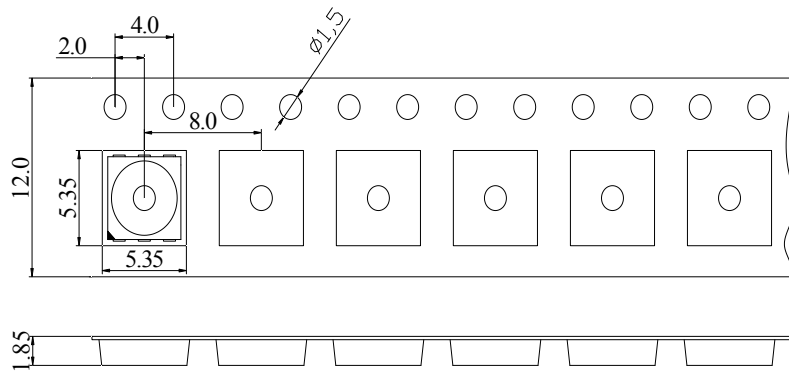

#### 包装: 7"卷盘/2K

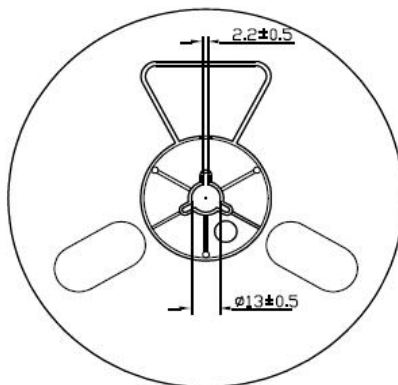

## 回流焊接条件

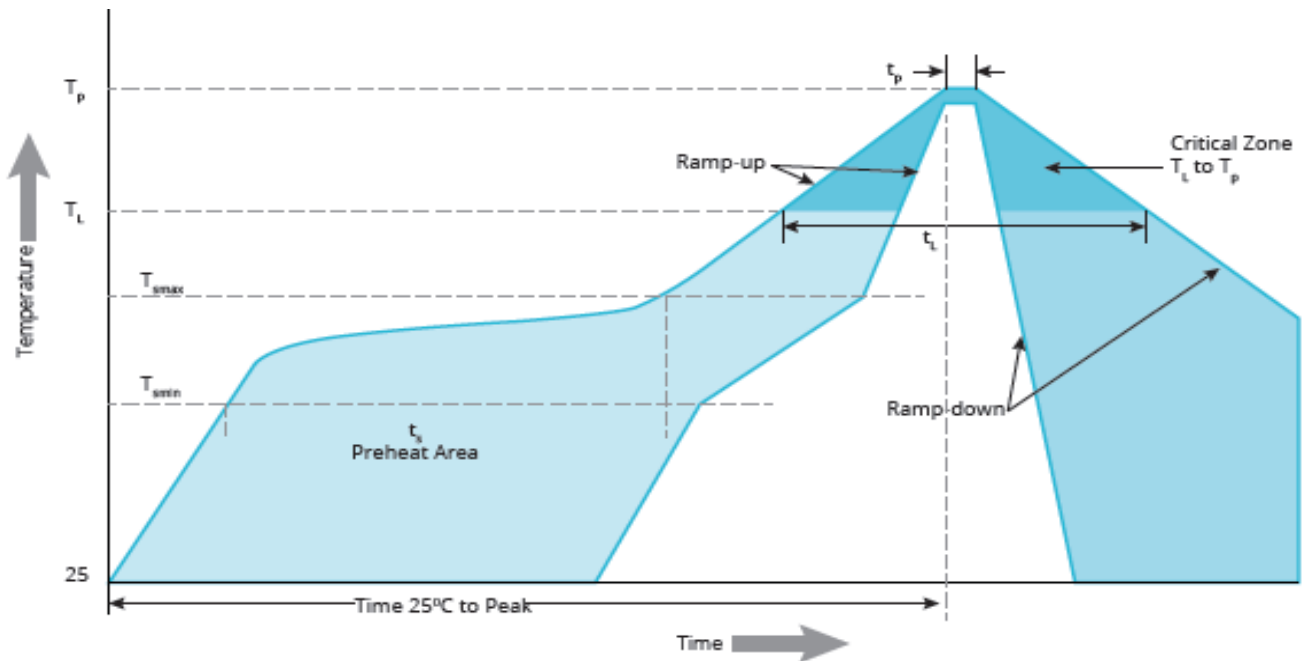

回流焊曲线说明:

特特征	无铅中温焊接	无铅高温焊接
预热: 最小温度 (T <sub>smin</sub> )	120°C	150°C
预热: 最大温度 (T <sub>smax</sub> )	160°C	200°C
预热: 时间 (t <sub>smin</sub> to t <sub>smax</sub> )	60-150 秒	60-150 秒
在以上温度保持: 温度(T <sub>L</sub> )	180°C	217°C
在以上时间保持: 时间(T <sub>L</sub> )	30-60 秒	30-60 秒
峰值温度	210°C	260°C
实际峰值温度维持±5°C内的时间	20-30 秒	5-10 秒
温度下降斜率	6°C/秒 (最大)	6°C/秒 (最大)
常温 25°C到峰值温度	6 分钟内	6 分钟内
注意事项:		
A. 中温、高温无铅回流焊建议的温度曲线如上图, 杜绝最高温度超过 (高温: 260°C/10S), (中温: 210°C/30S)		
B. 调试合适的温度, 选择对应的锡膏, 务必先做首件确认。		
C. 以上温度以实际炉温为准。		
D. 建议选择高温锡膏, 对应高温回流焊曲线。		

