



The DNA of tech.™

DIODES

FRED Pt® Gen 5 1200 V Hyperfast and Ultrafast Rectifiers

8 A to 60 A FRED Pt® Gen 5 1200 V Hyperfast and Ultrafast Rectifiers Reduce Conduction and Switching Losses



KEY BENEFITS

- Forward currents from 8 A to 60 A
- Offered in 2L TO-220AC / TO-247AD 2L (single diode) and 3L TO-220AB / TO-247AD 3L (dual diode)
- Available in X-type hyperfast and H-type ultrafast speed classes
 - X-type rectifiers offer the advantage of lower Q_{rr}
 - H-type devices feature lower forward voltage
- High temperature operation to +175 °C

APPLICATIONS

- Three-phase T-type PFC and output rectification stages for EV / HEV battery charging stations, booster stages for solar inverters, and UPS and welding applications

RESOURCES

- Datasheets: please see table on next page for the list of products
- For technical questions, contact DiodesAmericas@vishay.com, DiodesEurope@vishay.com, DiodesAsia@vishay.com
- Material categorization: for definitions of compliance, please see www.vishay.com/doc?99912



DIODES

FRED Pt[®] Gen 5 1200 V Hyperfast and Ultrafast Rectifiers

The DNA of tech.™

Vishay introduces new 8 A to 60 A FRED Pt[®] Gen 5 1200 V hyperfast and ultrafast rectifiers that offer the best conduction and switching loss trade-off for devices in their classes. These rectifiers are designed to increase the efficiency of high frequency converters, and hard- and soft-switched or resonant designs.

- Matched to operate with MOSFETs or high speed IGBTs
- Offer up to 10 % lower losses than competing silicon solutions
 - Cut the efficiency gap with SiC diodes in half
 - Provide a cost-effective alternative for applications with frequencies in the range of 50 kHz
- Offer the same forward voltage as competing solutions, while delivering up to 40 % lower switching losses and Q_{rr}

KEY SPECIFICATIONS: SINGLE DIODE, 1200 V, 8 A CURRENT RATING

PART NUMBER	V _R (V)	SPEED CLASS	I _{F(AV)} (A)	TYPICAL V _F (V), T _J = 125 °C, I _F = 8 A	TYPICAL Q _{rr} (nC), T _J = 125 °C, I _F = 8 A, V _R = 1000 V, dI _F /dt = 800 A/μs	TYPICAL t _{rr} (ns), T _J = 25 °C, I _F = 1 A, V _R = 30 V, dI _F /dt = 100 A/μs	PACKAGE
VS-E5TH0812-M3	1200	H	8	1.8	1350	33	2L TO-220AC
VS-E5TX0812-M3		X	8	2.1	960	27	2L TO-220AC

KEY SPECIFICATIONS: SINGLE DIODE, 1200 V, 15 A CURRENT RATING

PART NUMBER	V _R (V)	SPEED CLASS	I _{F(AV)} (A)	TYPICAL V _F (V), T _J = 125 °C, I _F = 15 A	TYPICAL Q _{rr} (nC), T _J = 125 °C, I _F = 15 A, V _R = 1000 V, dI _F /dt = 800 A/μs	TYPICAL t _{rr} (ns), T _J = 25 °C, I _F = 1 A, V _R = 30 V, dI _F /dt = 100 A/μs	PACKAGE
VS-E5TH1512-M3	1200	H	15	1.7	1985	37	2L TO-220AC
VS-E5TX1512-M3		X	15	2.1	1600	29	2L TO-220AC

KEY SPECIFICATIONS: SINGLE DIODE, 1200 V, 30 A CURRENT RATING

PART NUMBER	V _R (V)	SPEED CLASS	I _{F(AV)} (A)	TYPICAL V _F (V), T _J = 125 °C, I _F = 30 A	TYPICAL Q _{rr} (nC), T _J = 125 °C, I _F = 30 A, V _R = 1000 V, dI _F /dt = 800 A/μs	TYPICAL t _{rr} (ns), T _J = 25 °C, I _F = 1 A, V _R = 30 V, dI _F /dt = 100 A/μs	PACKAGE
VS-E5TH3012-M3	1200	H	30	1.7	3215	32	2L TO-220AC
VS-E5TX3012-M3		X	30	2.1	2400	26	2L TO-220AC
VS-E5PH3012L-N3		H	15	1.7	3215	32	TO-247AD 2L
VS-E5PX3012L-N3		X	15	2.1	2300	26	2L TO-220AC

KEY SPECIFICATIONS: SINGLE DIODE, 1200 V, 60 A CURRENT RATING

PART NUMBER	V _R (V)	SPEED CLASS	I _{F(AV)} (A)	TYPICAL V _F (V), T _J = 125 °C, I _F = 30 A	TYPICAL Q _{rr} (nC), T _J = 125 °C, I _F = 30 A, V _R = 1000 V, dI _F /dt = 800 A/μs	TYPICAL t _{rr} (ns), T _J = 25 °C, I _F = 1 A, V _R = 30 V, dI _F /dt = 100 A/μs	PACKAGE
VS-E5PX6012L-N3	1200	X	60	2.1	2950	30	TO-247AD 2L
VS-E5PH6012L-N3		H	60	1.7	4080	38	TO-247AD 2L



FRED Pt® Gen 5 1200 V Hyperfast and Ultrafast Rectifiers

The DNA of tech.™

KEY SPECIFICATIONS: DUAL DIODE, 1200 V, 30 A CURRENT RATING

PART NUMBER	V _R (V)	SPEED CLASS	I _{F(AV)} (A)	TYPICAL V _F (V) PER LEG, T _J = 125 °C, I _F = 15 A	TYPICAL Q _{rr} (nC) PER LEG, T _J = 125 °C, I _F = 15 A, V _R = 1000 V, di _F /dt = 800 A/μs	TYPICAL t _{rr} (ns) PER LEG, T _J = 25 °C, I _F = 1 A, V _R = 30 V, di _F /dt = 100 A/μs	PACKAGE
VS-C5TH3012-M3	1200	H	30 (2 x 15)	1.7	1985	37	3L TO-220AB
VS-C5TX3012-M3		X	30 (2 x 15)	2.1	1600	29	3L TO-220AB
VS-C5PH3012L-N3		H	30 (2 x 15)	1.7	1200	37	TO-247AD 3L
VS-C5PX3012L-N3		X	30 (2 x 15)	2.1	1600	29	TO-247AD 3L

KEY SPECIFICATIONS: DUAL DIODE, 1200 V, 60 A CURRENT RATING

PART NUMBER	V _R (V)	SPEED CLASS	I _{F(AV)} (A)	TYPICAL V _F (V) PER LEG, T _J = 125 °C, I _F = 30 A	TYPICAL Q _{rr} (nC) PER LEG, T _J = 125 °C, I _F = 30 A, V _R = 1000 V, di _F /dt = 800 A/μs	TYPICAL t _{rr} (ns) PER LEG, T _J = 25 °C, I _F = 1 A, V _R = 30 V, di _F /dt = 100 A/μs	PACKAGE
VS-C5PH6012L-N3	1200	H	60 (2 x 30)	1.7	3215	32	TO-247AD 3L
VS-C5PX6012L-N3		X	60 (2 x 30)	2.1	2400	26	TO-247AD 3L

Three-Level T-Type PFC - Typical Application Schematic

Featuring a unique combination of low conduction and switching losses, these 1200 V rectifiers are the right choice for high frequency converters, both hard switched and soft switched / resonant.

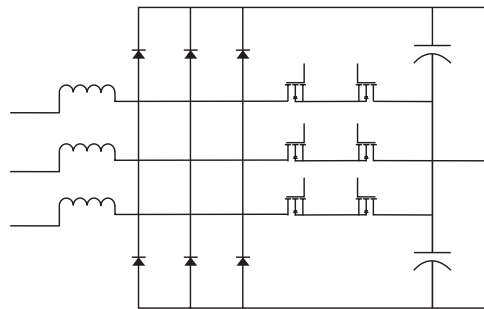

Specifically designed to improve the efficiency of PFC and output rectification stages of EV / HEV battery charging stations, the booster stage of solar inverters, and UPS applications, these 1200 V devices are perfectly matched to operate with MOSFETs or high speed IGBTs.

Efficiency of Real-World T-Type PFC vs. Output Power Using Various Diodes, Tested at 50 °C Ambient

