

TITLE : DV332X2M-NV0
Final Product Specification
Rev. P2

BEIJING BOE Display TECHNOLOGY

REVISION HISTORY

() preliminary specification

(●) Final specification

| Revision No. | Page | Description of changes | Date | Prepared |
|--------------|------|---------------------------|--------------|-----------|
| Rev.P0 | | Initial Release | June.27.2018 | Tian Ming |
| Rev.P1 | 30 | Add B/C strengthening rib | July.18.2018 | Tian Ming |
| Rev.P2 | 9 | Luminance change | Feb.14.2019 | Tian Ming |
| | | | | |
| | | | | |
| | | | | |
| | | | | |

Contents

| No. | Item | Page |
|------------|--|-------------|
| 1.0 | General Description | 4 |
| 2.0 | Absolute Maximum Ratings | 6 |
| 3.0 | Electrical Specifications | 7 |
| 4.0 | Optical Specifications | 8 |
| 5.0 | Interface Connection | 10 |
| 6.0 | Signal Timing Specifications | 14 |
| 7.0 | Signal Timing Waveforms of Interface Signal | 16 |
| 8.0 | Input Signals, Display Colors & Gray Scale of Colors | 18 |
| 9.0 | Power Sequence | 19 |
| 10.0 | Mechanical Characteristics | 20 |
| 11.0 | Reliability Test | 21 |
| 12.0 | Handling & Cautions | 22 |
| 13.0 | Product Serial Number | 23 |
| 14.0 | Packing | 24 |
| 15.0 | Appendix | 27 |

1.0 GENERAL DESCRIPTION

1.1 Introduction

DV332X2M-NV0 is a color active matrix TFT LCD module using amorphous silicon TFT's (Thin Film Transistors) as an active switching devices. This module has a 33.2 inch diagonally measured active area with 2K resolutions (1920 horizontal by 1920 vertical pixel array). Each pixel is divided into RED, GREEN, BLUE dots which are arranged in vertical stripe and this module can display 16.7M colors. The TFT-LCD panel used for this module is adapted for a low reflection and higher color type.

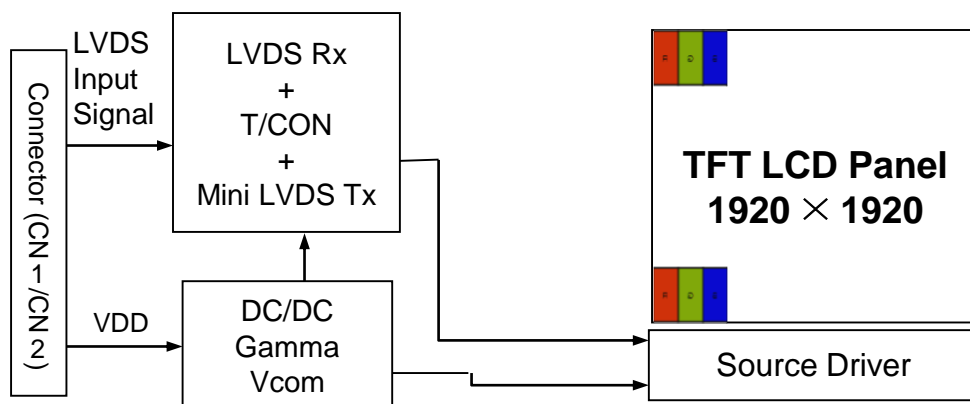

1.2 Features

- LVDS Interface with 4 pixel / clock (Jeida Format)
- High-speed response
- 0.5t Glass
- 8-bit color depth , display 16. 7M colors
- Incorporated edge type back-light (One Light Bar)
- High luminance and contrast ratio, low reflection and wide viewing angle
- DE (Data Enable) only
- RoHS/Halogen Free
- Gamma Correction
- Reverse type

1.3 Application

- Desktop Type of PC & Workstation Use
- Slim-Size Display for Stand-alone Monitor
- Display Terminals for Control System
- Monitors for Process Controller

1.4 General Specification

The followings are general specifications at the model DV332X2M-NV0.

<Table 1. General Specifications>

| Parameter | Specification | Unit | Remarks |
|---------------------|---|--------|-------------------------|
| Active area | 596.16 (H) × 596.16 (V) | mm | |
| Number of pixels | 1920(H) × 1920(V) | pixels | |
| Pixel pitch | 0.1035(H) x 0.3105(V) | mm | |
| Pixel arrangement | RGB Vertical stripe | - | |
| Display colors | 16.7M | colors | |
| Display mode | Normally Black | - | |
| Dimensional outline | 612.96(H) × 612.96 (V) × 7.7(D) typ | mm | Detail refer to drawing |
| Weight | 4.88 ± 0.1 | Kg | |
| Surface Treatment | AG 25 %, 3H | - | |
| Back-light | Left side 1-LED Light bar & Right side 1-LED Light bar | - | |

2.0 ABSOLUTE MAXIMUM RATINGS

The followings are maximum values which, if exceed, may cause faulty operation or damage to the unit. The operational and non-operational maximum voltage and current values are listed in Table 2.

< Table 2. Absolute Maximum Ratings >

[VSS=GND=0V]

| Parameter | Symbol | Min. | Max. | Unit | Remarks |
|-------------------------------------|---------------|---------|--------------|------|------------|
| Power Supply Voltage | V_{DD} | 4.5 | 5.5 | V | Ta = 25 °C |
| Logic Supply Voltage | V_{IN} | VSS-0.3 | $V_{DD}+0.3$ | V | |
| Operating Temperature | T_{OP} | 0 | +50 | °C | 1) |
| Storage Temperature | T_{ST} | -20 | +60 | °C | 1) |
| LCM Surface Temperature (Operation) | $T_{surface}$ | 0 | +65 | °C | 2) |

Note : 1) Temperature and relative humidity range are shown in the figure below.

Wet bulb temperature should be 39 °C max. and no condensation of water.

2) LCM Surface Temperature should be Min. 0°C and Max. 65°C under the VLCD=5.0V, fV=60Hz, 25°C ambient Temp. No humidity control and LED string current is typical Value.

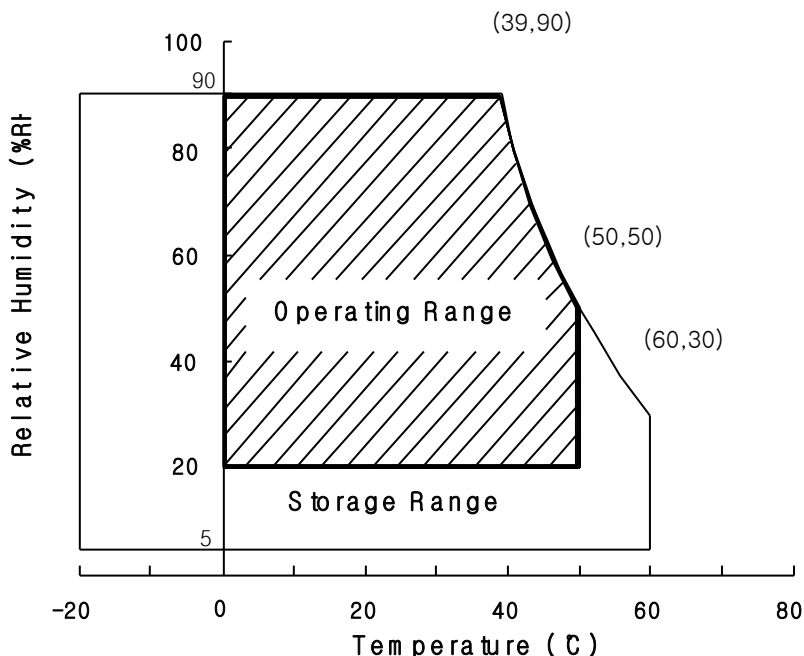

3.0 ELECTRICAL SPECIFICATIONS

3.1 Electrical Specifications

< Table 3. Electrical specifications >

[Ta = 25 ± 2 °C]

| Parameter | | Min. | Typ. | Max. | Unit | Remarks |
|---|--------------------|--------|------|------|------|-------------------------------|
| Power Supply Voltage | V _{DD} | 4.5 | 5.0 | 5.5 | V | Note1 |
| Power Supply Current | I _{DD} | - | 1400 | 2000 | mA | |
| In-Rush Current | I _{RUSH} | - | 3.0 | 4.0 | A | Note 2 |
| Permissible Input Ripple Voltage | V _{RF} | - | - | 300 | mV | V _{DD} = 5.0V |
| High Level Differential Input Threshold Voltage | V _{TH} | - | - | +100 | mV | V _{IC} =1.2V |
| Low Level Differential Input Threshold Voltage | V _{TL} | -100 | - | - | mV | |
| Differential input voltage | V _{ID} | 100 | - | 600 | mV | |
| Differential input common mode voltage | V _{cm} | 0.7 | - | 1.6 | V | |
| LED Voltage | V _L | 2.9 | 3.0 | 3.1 | V | |
| LED Channel Voltage | V _L | 55.1 | 57.0 | 58.9 | V | |
| LED Channel Current | I _L | - | 100 | - | mA | |
| LED Lifetime | | 30,000 | - | - | Hrs | I _L =100 mA |
| Power Consumption | P _D | | 7 | 10 | W | |
| | P _{BL} | - | 45.6 | 47.1 | W | I _L =100mA, Note 3 |
| | P _{total} | - | 52.6 | 57.1 | W | |

Notes : 1. The supply voltage is measured and specified at the interface connector of LCM.

The current draw and power consumption specified is for VDD=5.0V, Frame rate=60Hz. Test Pattern of power supply current

- a) Typ : Color Bar pattern
- b) Max : Vertical Sub Line L255

2. Duration of rush current is about 2 ms and rising time of VDD is 520 μs ± 20 %

3. Calculated value for reference (V_L × I_L) × 4(channel) × 2(Light Bar) excluding driver loss. (LED Light bar: 19S4P)

| Parameter | | Min. | Typ. | Max. | Unit | Remarks |
|---|------------------|--------|------|------|------|-----------|
| LED Light Bar Input Voltage Per Input Pin | V _{PIN} | 55.1 | 57.0 | 58.9 | V | Duty 100% |
| LED Light Bar Input Current Per Input Pin | I _{PIN} | - | 100 | - | mA | Note1,2, |
| LED Power Consumption | P _{BL} | - | 45.6 | 47.1 | W | Note 3 |
| LED Life-Time | - | 30,000 | - | | Hrs | Note 4 |

LED bar consists of 76LED packages,4 strings(parallel)*19packages(serial)

Note1: There are 2 light bar ,and the specified current is input LED chip 100% duty current

Note2: The sense current of each input pin is 100mA

Note3: $P_{BL}=4 \text{ Input pins} \times V_{PIN} \times I_{PIN}$

Note4: The lifetime is determined as the time at which luminance of LED become 50% of the initial brightness or not normal lighting at I_{PIN}=100mA on condition of continuous operating at 25 ± 2 °C

4.0 OPTICAL SPECIFICATION

4.1 Overview

The test of Optical specifications shall be measured in a dark room (ambient luminance ≤ 1 lux and temperature = $25 \pm 2^\circ\text{C}$) with the equipment of Luminance meter system (Goniometer system and TOPCONE PR730) and test unit shall be located at an approximate distance 50cm from the LCD surface at a viewing angle of θ and Φ equal to 0° . We refer to $\theta_{\theta=0}$ ($=\theta_3$) as the 3 o'clock direction (the "right"), $\theta_{\theta=90}$ ($=\theta_{12}$) as the 12 o'clock direction ("upward"), $\theta_{\theta=180}$ ($=\theta_9$) as the 9 o'clock direction ("left") and $\theta_{\theta=270}$ ($=\theta_6$) as the 6 o'clock direction ("bottom"). While scanning θ and/or Φ , the center of the measuring spot on the Display surface shall stay fixed. The measurement shall be executed after 30 minutes warm-up period. VDD shall be 5.0V +/-10% at 25°C . Optimum viewing angle direction is 6 'clock.

4.2 Optical Specifications

[VDD = 5.0V, Frame rate = 60Hz, Clock = 78MHz, $I_{BL} = 160\text{mA}$, $T_a = 25 \pm 2^\circ\text{C}$]
 < Table 4. Module Optical >

| Parameter | | Symbol | Condition | Min. | Typ. | Max. | Unit | Remark |
|----------------------------|------------|---------------|--|-------|-------|-------|-------------------|--------|
| Viewing Angle range | Horizontal | θ_3 | CR > 10 | 85 | 89 | - | Deg. | Note 1 |
| | | θ_9 | | 85 | 89 | - | Deg. | |
| | Vertical | θ_{12} | | 85 | 89 | - | Deg. | |
| | | θ_6 | | 85 | 89 | - | Deg. | |
| Luminance Contrast ratio | | CR | | 700 | 1000 | | | Note 2 |
| Luminance of White | | Y_w | | 350 | 420 | - | cd/m ² | Note 3 |
| White luminance uniformity | | ΔY | | - | 75 | - | % | Note 4 |
| NTSC Color Gamut | | C.G. | | - | 72 | - | % | |
| Reproduction of color | White | W_x | $\theta = 0^\circ$ (Center) Normal Viewing Angle | 0.250 | 0.280 | 0.310 | - | Note 5 |
| | | W_y | | 0.260 | 0.290 | 0.320 | - | |
| | Red | R_x | | 0.596 | 0.626 | 0.656 | - | |
| | | R_y | | 0.311 | 0.341 | 0.371 | - | |
| | Green | G_x | | 0.281 | 0.311 | 0.341 | - | |
| | | G_y | | 0.617 | 0.647 | 0.677 | - | |
| | Blue | B_x | | 0.123 | 0.153 | 0.183 | - | |
| | | B_y | | 0.024 | 0.054 | 0.084 | - | |
| Response Time | GTG | T_g | | - | 8 | 10 | ms | Note 6 |

Note :

- Viewing angle is the angle at which the contrast ratio is greater than 10. The viewing are determined for the horizontal or 3, 9 o'clock direction and the vertical or 6, 12 o'clock direction with respect to the optical axis which is normal to the LCD surface.
- Contrast measurements shall be made at viewing angle of $\theta = 0^\circ$ and at the center of the LCD surface. Luminance shall be measured with all pixels in the view field set first to white, then to the dark (black) state. (See FIGURE 1 shown in Appendix) Luminance Contrast Ratio (CR) is defined mathematically.

$$CR = \frac{\text{Luminance when displaying a white raster}}{\text{Luminance when displaying a black raster}}$$

- Center Luminance of white is defined as the LCD surface. Luminance shall be measured with all pixels in the view field set first to white. This measurement shall be taken at the locations shown in FIGURE 2 for a total of the measurements per display.
- The White luminance uniformity on LCD surface is then expressed as :
 $\Delta Y = (\text{Minimum Luminance of 9points} / \text{Maximum Luminance of 9points}) * 100$
 (See FIGURE 2 shown in Appendix).
- The color chromaticity coordinates specified in Table 5. shall be calculated from the spectral data measured with all pixels first in red, green, blue and white. Measurements shall be made at the center of the panel.
- Response time T_g is the average time required for display transition by switching the input signal as below table and is based on Frame rate $f_V = 60\text{Hz}$ to optimize. Each time in below table is defined as appendix Figure 3and shall be measured by switching the input signal for "any level of gray(bright)"and "any level of gray(dark)".

| Measured Response Time | Target | | | | | | | | | | | | | | | | |
|------------------------|--------|----|----|----|----|----|----|-----|-----|-----|-----|-----|-----|-----|-----|-----|-----|
| | 0 | 15 | 31 | 47 | 63 | 79 | 95 | 111 | 127 | 143 | 159 | 175 | 191 | 207 | 223 | 239 | 255 |
| 0 | | | | | | | | | | | | | | | | | |
| 15 | | | | | | | | | | | | | | | | | |
| 31 | | | | | | | | | | | | | | | | | |
| 47 | | | | | | | | | | | | | | | | | |
| 63 | | | | | | | | | | | | | | | | | |
| 79 | | | | | | | | | | | | | | | | | |
| 95 | | | | | | | | | | | | | | | | | |
| 111 | | | | | | | | | | | | | | | | | |
| 127 | | | | | | | | | | | | | | | | | |
| 143 | | | | | | | | | | | | | | | | | |
| 159 | | | | | | | | | | | | | | | | | |
| 175 | | | | | | | | | | | | | | | | | |
| 191 | | | | | | | | | | | | | | | | | |
| 207 | | | | | | | | | | | | | | | | | |
| 223 | | | | | | | | | | | | | | | | | |
| 239 | | | | | | | | | | | | | | | | | |
| 255 | | | | | | | | | | | | | | | | | |

- Cross-Talk of one area of the LCD surface by another shall be measured by comparing the luminance (Y_A) of a 25mm diameter area, with all display pixels set to a gray level, to the luminance (Y_B) of that same area when any adjacent area is driven dark. (See FIGURE 4 shown in Appendix).

5.0 INTERFACE CONNECTION.

5.1 Electrical Interface Connection

5.1.1 LED Light Bar

-LED connector : 3707K-X06X-08X manufactured by E&T

< Table 5. LED Light Bar >

| Pin No | Symbol | Description |
|--------|--------|-------------------------------|
| 1 | IRLED1 | LED current sense for string1 |
| 2 | IRLED2 | LED current sense for string2 |
| 3 | VLED | LED power supply |
| 4 | VLED | LED power supply |
| 5 | IRLED3 | LED current sense for string3 |
| 6 | IRLED4 | LED current sense for string4 |

5.2 Electrical Interface Connection

- CN1 Module Side Connector : IS050-C51B-C39-Sor Equivalent

| No | Symbol | Function | No | Symbol | Function |
|----|----------|---|----|----------|--|
| 1 | GND | Power Ground | 27 | NC | |
| 2 | NC | | 28 | CH4_0- | FOURTH_ Negative LVDS differential data input |
| 3 | NC | | 29 | CH4_0+ | FOURTH_ Positive LVDS differential data input |
| 4 | NC | | 30 | CH4_1- | FOURTH_ Negative LVDS differential data input |
| 5 | NC | | 31 | CH4_1+ | FOURTH_ Positive LVDS differential data input |
| 6 | NC | | 32 | CH4_2- | FOURTH_ Negative LVDS differential data input |
| 7 | NC | | 33 | CH4_2+ | FOURTH_ Positive LVDS differential data input |
| 8 | NC | | 34 | GND | Power Ground |
| 9 | NC | | 35 | CH4_CLK- | FOURTH_ Negative LVDS differential clock input |
| 10 | NC | | 36 | CH4_CLK+ | FOURTH_ Positive LVDS differential clock input |
| 11 | NC | | 37 | GND | Power Ground |
| 12 | CH3_0- | THIRD_ Negative LVDS differential data input | 38 | CH4_3- | FOURTH_ Negative LVDS differential data input |
| 13 | CH3_0+ | THIRD_ Positive LVDS differential data input | 39 | CH4_3+ | FOURTH_ Positive LVDS differential data input |
| 14 | CH3_1- | THIRD_ Negative LVDS differential data input | 40 | NC | |
| 15 | CH3_1+ | THIRD_ Positive LVDS differential data input | 41 | NC | |
| 16 | CH3_2- | THIRD_ Negative LVDS differential data input | 42 | NC | |
| 17 | CH3_2+ | THIRD_ Positive LVDS differential data input | 43 | NC | |
| 18 | GND | Power Ground | 44 | GND | Power Ground |
| 19 | CH3_CLK- | THIRD_ Negative LVDS differential clock input | 45 | GND | Power Ground |
| 20 | CH3_CLK+ | THIRD_ Positive LVDS differential clock input | 46 | GND | Power Ground |
| 21 | GND | Power Ground | 47 | NC | |
| 22 | CH3_3- | THIRD_ Negative LVDS differential data input | 48 | VIN | Power +5V |
| 23 | CH3_3+ | THIRD_ Positive LVDS differential data input | 49 | VIN | Power +5V |
| 24 | NC | | 50 | VIN | Power +5V |
| 25 | NC | | 51 | VIN | Power +5V |
| 26 | GND | Power Ground | | | |

5.2 Electrical Interface Connection

- CN2 Module Side Connector : IS050-C41B-C39-Sor Equivalent

| No | Symbol | Function | No | Symbol | Function |
|----|----------|---|----|----------|--|
| 1 | NC | | 22 | NC | |
| 2 | NC | | 23 | NC | |
| 3 | NC | | 24 | GND | Power Ground |
| 4 | NC | | 25 | GND | Power Ground |
| 5 | NC | | 26 | CH2_0- | SECOND_ Negative LVDS differential data input |
| 6 | NC | | 27 | CH2_0+ | SECOND_ Positive LVDS differential data input |
| 7 | NC | | 28 | CH2_1- | SECOND_ Negative LVDS differential data input |
| 8 | NC | | 29 | CH2_1+ | SECOND_ Positive LVDS differential data input |
| 9 | GND | Power Ground | 30 | CH2_2- | SECOND_ Negative LVDS differential data input |
| 10 | CH1_0- | FIRST_ Negative LVDS differential data input | 31 | CH2_2+ | SECOND_ Positive LVDS differential data input |
| 11 | CH1_0+ | FIRST_ Positive LVDS differential data input | 32 | GND | Power Ground |
| 12 | CH1_1- | FIRST_ Negative LVDS differential data input | 33 | CH2_CLK- | SECOND_ Negative LVDS differential clock input |
| 13 | CH1_1+ | FIRST_ Positive LVDS differential data input | 34 | CH2_CLK+ | SECOND_ Positive LVDS differential clock input |
| 14 | CH1_2- | FIRST_ Negative LVDS differential data input | 35 | GND | Power Ground |
| 15 | CH1_2+ | FIRST_ Positive LVDS differential data input | 36 | CH2_3- | SECOND_ Negative LVDS differential data input |
| 16 | GND | Power Ground | 37 | CH2_3+ | SECOND_ Positive LVDS differential data input |
| 17 | CH1_CLK- | FIRST_ Negative LVDS differential clock input | 38 | NC | |
| 18 | CH1_CLK+ | FIRST_ Positive LVDS differential clock input | 39 | NC | |
| 19 | GND | Power Ground | 40 | GND | Power Ground |
| 20 | CH1_3- | FIRST_ Negative LVDS differential data input | 41 | GND | Power Ground |
| 21 | CH1_3+ | FIRST_ Positive LVDS differential data input | | | |

5.2 Data Input Format

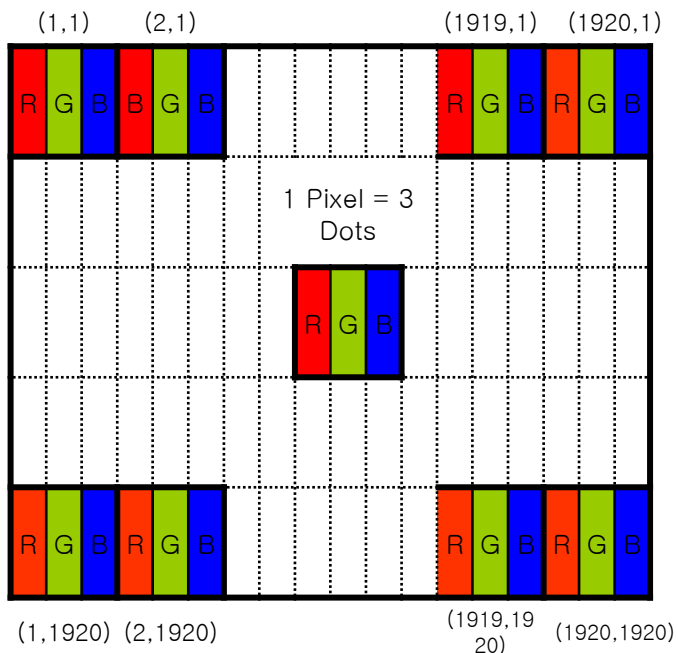

Display Position of Input Data (V-H)

5.3 Back-light Interface Connection

-LED connector : **3707K-X06X-08X** manufactured by **E&T**

| Pin | Function |
|-----|----------------------------|
| 1 | Channel 1 Current Feedback |
| 2 | Channel 2 Current Feedback |
| 3 | LED Power Supply |
| 4 | LED Power Supply |
| 5 | Channel3 Current Feedback |
| 6 | Channel4 Current Feedback |

6.0 SIGNAL TIMING SPECIFICATION**6.1 The DV332X2M-NV0 is operated by the DE only.**

| Item | Symbols | | Min | Typ | Max | Unit | Note |
|---------------------|-----------------------------|------|-------|-------|-------|------|------|
| DCLK | Period | tCLK | 14.08 | 14.78 | 15.56 | ns | |
| | Frequency | - | 64.3 | 67.6 | 71 | MHz | |
| Hsync | Period | tHP | 550 | 550 | 550 | tCLK | |
| | Horizontal Valid | tHV | 480 | 480 | 480 | tCLK | |
| | Horizontal Blank | tHB | 70 | 70 | 70 | | |
| | Frequency | fH | 121.1 | 123 | 124.7 | KHz | |
| Vsync | Period | tVP | 2049 | 2050 | 2051 | tHP | |
| | Vertical Valid | tVV | 1920 | 1920 | 1920 | tHP | |
| | Vertical Blank | tVB | 129 | 130 | 131 | tHP | |
| | Frequency | fV | 57 | 60 | 63 | Hz | |
| LVDS Receiver clock | Input spread spectrum ratio | SSr | - | - | - | % | |

6.2 LVDS Rx Interface Timing Parameter

The specification of the LVDS Rx interface timing parameter is shown in Table 4.

<Table 4. LVDS Rx Interface Timing Specification>

| Item | Symbol | Min | Typ | Max | Unit | Remark |
|--------------|--------|-----------------|-------------|-----------------|------|--------|
| CLKIN Period | tRCIP | 14.08 | 14.78 | 15.56 | nsec | |
| Input Data 0 | tRIP1 | -0.4 | 0.0 | +0.4 | nsec | |
| Input Data 1 | tRIP0 | tRCIP/7-0.4 | tRCIP/7 | tRCIP/7+0.4 | nsec | |
| Input Data 2 | tRIP6 | 2 × tRCIP/7-0.4 | 2 × tRCIP/7 | 2 × tRCIP/7+0.4 | nsec | |
| Input Data 3 | tRIP5 | 3 × tRCIP/7-0.4 | 3 × tRCIP/7 | 3 × tRCIP/7+0.4 | nsec | |
| Input Data 4 | tRIP4 | 4 × tRCIP/7-0.4 | 4 × tRCIP/7 | 4 × tRCIP/7+0.4 | nsec | |
| Input Data 5 | tRIP3 | 5 × tRCIP/7-0.4 | 5 × tRCIP/7 | 5 × tRCIP/7+0.4 | nsec | |
| Input Data 6 | tRIP2 | 6 × tRCIP/7-0.4 | 6 × tRCIP/7 | 6 × tRCIP/7+0.4 | nsec | |

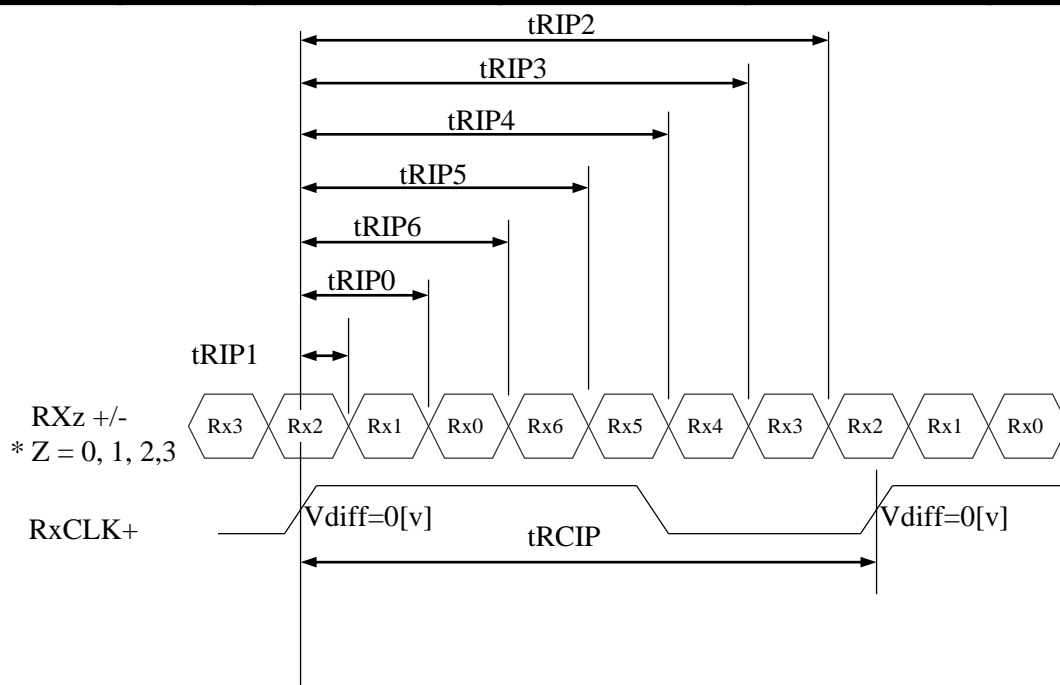

* Vdiff = (RXz+)-(RXz-),..., (RXCLK+)-(RXCLK-)

7.0 SIGNAL TIMING WAVEFORMS OF INTERFACE SIGNAL

7.1 Sync Timing Waveforms

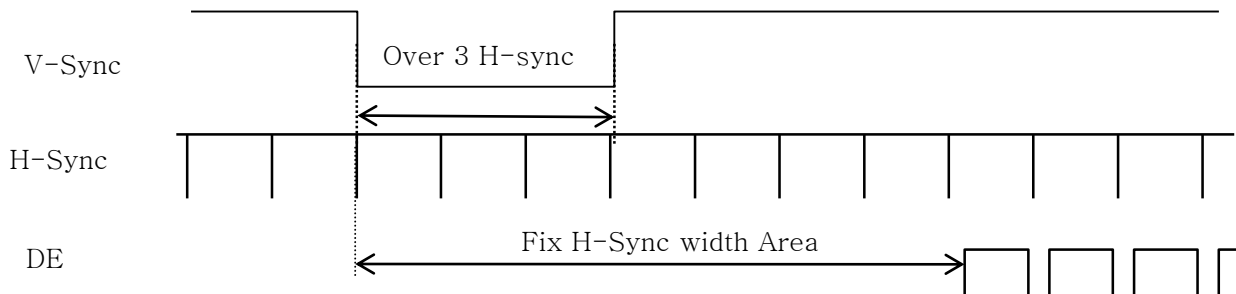

- 1) Need over 3 H-sync during V-Sync Low
- 2) Fix H-Sync width from V-Sync falling edge to first rising edge

7.2 Vertical Timing Waveforms

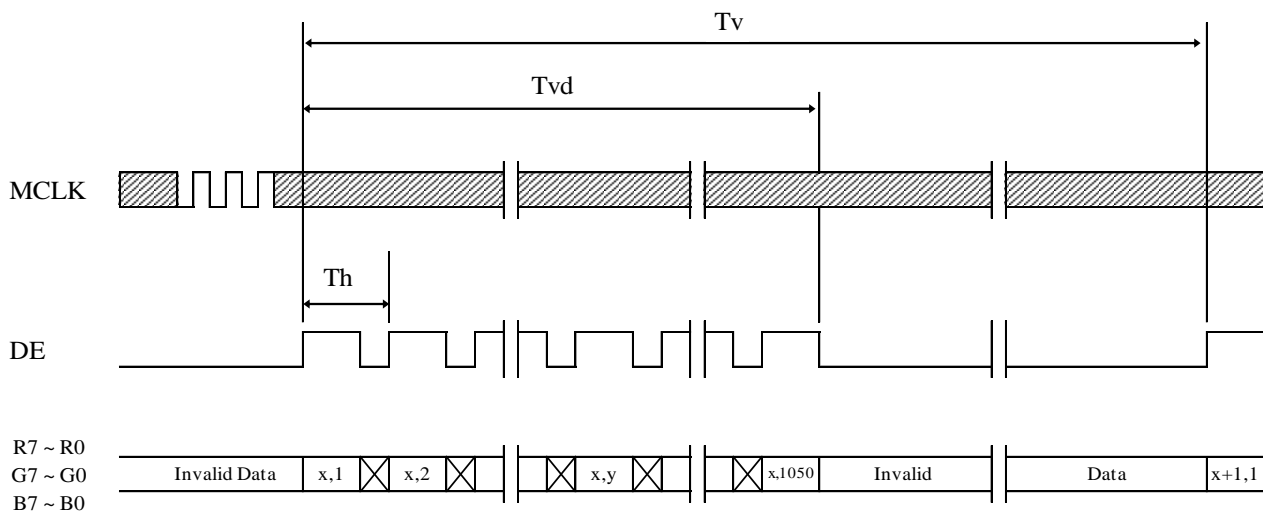

7.3 Horizontal Timing Waveforms

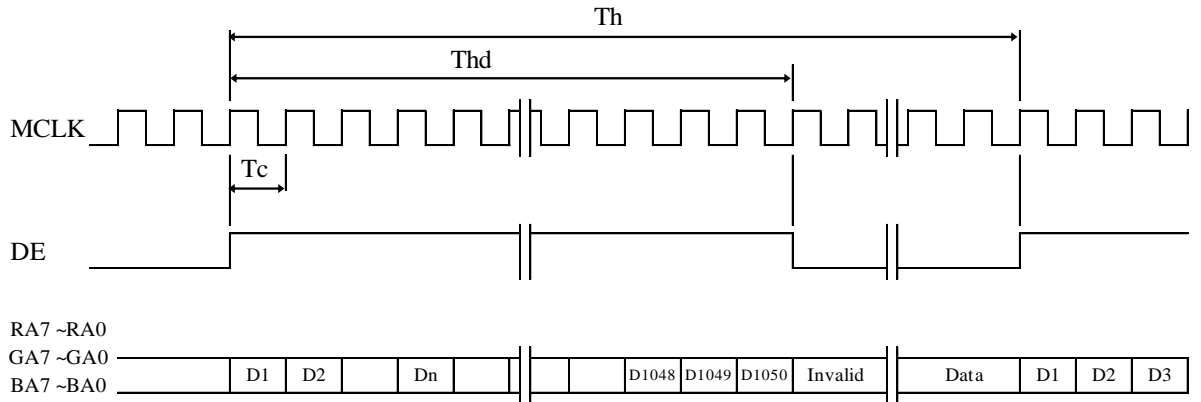

8.0 INPUT SIGNALS, BASIC DISPLAY COLORS & GRAY SCALE OF COLORS

| Color & Gray Scale | | RED DATA | | | | | | | | GREEN DATA | | | | | | | | BLUE DATA | | | | | | | |
|---------------------|----------|----------|----|----|----|----|----|----|----|------------|----|----|----|----|----|----|----|-----------|----|----|----|----|----|----|----|
| | | R7 | R6 | R5 | R4 | R3 | R2 | R1 | R0 | G7 | G6 | G5 | G4 | G3 | G2 | G1 | G0 | B7 | B6 | B5 | B4 | B3 | B2 | B1 | B0 |
| Basic Colors | Black | 0 | 0 | 0 | 0 | 0 | 0 | 0 | 0 | 0 | 0 | 0 | 0 | 0 | 0 | 0 | 0 | 0 | 0 | 0 | 0 | 0 | 0 | 0 | 0 |
| | Blue | 0 | 0 | 0 | 0 | 0 | 0 | 0 | 0 | 0 | 0 | 0 | 0 | 0 | 0 | 0 | 0 | 1 | 1 | 1 | 1 | 1 | 1 | 1 | 1 |
| | Green | 0 | 0 | 0 | 0 | 0 | 0 | 0 | 0 | 1 | 1 | 1 | 1 | 1 | 1 | 1 | 1 | 0 | 0 | 0 | 0 | 0 | 0 | 0 | 0 |
| | Cyan | 0 | 0 | 0 | 0 | 0 | 0 | 0 | 0 | 1 | 1 | 1 | 1 | 1 | 1 | 1 | 1 | 1 | 1 | 1 | 1 | 1 | 1 | 1 | 1 |
| | Red | 1 | 1 | 1 | 1 | 1 | 1 | 1 | 1 | 0 | 0 | 0 | 0 | 0 | 0 | 0 | 0 | 0 | 0 | 0 | 0 | 0 | 0 | 0 | 0 |
| | Magenta | 1 | 1 | 1 | 1 | 1 | 1 | 1 | 1 | 0 | 0 | 0 | 0 | 0 | 0 | 0 | 0 | 1 | 1 | 1 | 1 | 1 | 1 | 1 | 1 |
| | Yellow | 1 | 1 | 1 | 1 | 1 | 1 | 1 | 1 | 1 | 1 | 1 | 1 | 1 | 1 | 1 | 1 | 0 | 0 | 0 | 0 | 0 | 0 | 0 | 0 |
| | White | 1 | 1 | 1 | 1 | 1 | 1 | 1 | 1 | 1 | 1 | 1 | 1 | 1 | 1 | 1 | 1 | 1 | 1 | 1 | 1 | 1 | 1 | 1 | 1 |
| Gray Scale of RED | Black | 0 | 0 | 0 | 0 | 0 | 0 | 0 | 0 | 0 | 0 | 0 | 0 | 0 | 0 | 0 | 0 | 0 | 0 | 0 | 0 | 0 | 0 | 0 | |
| | △ | 0 | 0 | 0 | 0 | 0 | 0 | 1 | 0 | 0 | 0 | 0 | 0 | 0 | 0 | 0 | 0 | 0 | 0 | 0 | 0 | 0 | 0 | 0 | |
| | Darker | 0 | 0 | 0 | 0 | 0 | 0 | 1 | 0 | 0 | 0 | 0 | 0 | 0 | 0 | 0 | 0 | 0 | 0 | 0 | 0 | 0 | 0 | 0 | |
| | △ | | | | | | | | | | | | | | | | | | | | | | | | |
| | ▽ | | | | | | | | | | | | | | | | | | | | | | | | |
| | Brighter | 1 | 1 | 1 | 1 | 1 | 1 | 0 | 1 | 0 | 0 | 0 | 0 | 0 | 0 | 0 | 0 | 0 | 0 | 0 | 0 | 0 | 0 | 0 | |
| | ▽ | 1 | 1 | 1 | 1 | 1 | 1 | 0 | 0 | 0 | 0 | 0 | 0 | 0 | 0 | 0 | 0 | 0 | 0 | 0 | 0 | 0 | 0 | 0 | |
| | Red | 1 | 1 | 1 | 1 | 1 | 1 | 1 | 0 | 0 | 0 | 0 | 0 | 0 | 0 | 0 | 0 | 0 | 0 | 0 | 0 | 0 | 0 | 0 | |
| Gray Scale of GREEN | Black | 0 | 0 | 0 | 0 | 0 | 0 | 0 | 0 | 0 | 0 | 0 | 0 | 0 | 0 | 0 | 0 | 0 | 0 | 0 | 0 | 0 | 0 | 0 | |
| | △ | 0 | 0 | 0 | 0 | 0 | 0 | 0 | 0 | 0 | 0 | 0 | 0 | 0 | 0 | 1 | 0 | 0 | 0 | 0 | 0 | 0 | 0 | 0 | |
| | Darker | 0 | 0 | 0 | 0 | 0 | 0 | 0 | 0 | 0 | 0 | 0 | 0 | 0 | 1 | 0 | 0 | 0 | 0 | 0 | 0 | 0 | 0 | 0 | |
| | △ | | | | | | | | | | | | | | | | | | | | | | | | |
| | ▽ | | | | | | | | | | | | | | | | | | | | | | | | |
| | Brighter | 0 | 0 | 0 | 0 | 0 | 0 | 0 | 1 | 1 | 1 | 1 | 1 | 1 | 0 | 1 | 0 | 0 | 0 | 0 | 0 | 0 | 0 | 0 | |
| | ▽ | 0 | 0 | 0 | 0 | 0 | 0 | 0 | 1 | 1 | 1 | 1 | 1 | 1 | 0 | 0 | 0 | 0 | 0 | 0 | 0 | 0 | 0 | 0 | |
| | Green | 0 | 0 | 0 | 0 | 0 | 0 | 0 | 1 | 1 | 1 | 1 | 1 | 1 | 1 | 1 | 0 | 0 | 0 | 0 | 0 | 0 | 0 | 0 | |
| Gray Scale of BLUE | Black | 0 | 0 | 0 | 0 | 0 | 0 | 0 | 0 | 0 | 0 | 0 | 0 | 0 | 0 | 0 | 0 | 0 | 0 | 0 | 0 | 0 | 0 | 0 | |
| | △ | 0 | 0 | 0 | 0 | 0 | 0 | 0 | 0 | 0 | 0 | 0 | 0 | 0 | 0 | 0 | 0 | 0 | 0 | 0 | 0 | 0 | 0 | 1 | |
| | Darker | 0 | 0 | 0 | 0 | 0 | 0 | 0 | 0 | 0 | 0 | 0 | 0 | 0 | 0 | 0 | 0 | 0 | 0 | 0 | 0 | 0 | 1 | 0 | |
| | △ | | | | | | | | | | | | | | | | | | | | | | | | |
| | ▽ | | | | | | | | | | | | | | | | | | | | | | | | |
| | Brighter | 0 | 0 | 0 | 0 | 0 | 0 | 0 | 0 | 0 | 0 | 0 | 0 | 0 | 0 | 0 | 1 | 1 | 1 | 1 | 1 | 1 | 0 | 1 | |
| | ▽ | 0 | 0 | 0 | 0 | 0 | 0 | 0 | 0 | 0 | 0 | 0 | 0 | 0 | 0 | 0 | 1 | 1 | 1 | 1 | 1 | 1 | 1 | 0 | |
| | Blue | 0 | 0 | 0 | 0 | 0 | 0 | 0 | 0 | 0 | 0 | 0 | 0 | 0 | 0 | 0 | 1 | 1 | 1 | 1 | 1 | 1 | 1 | 1 | |
| Gray Scale of WHITE | Black | 0 | 0 | 0 | 0 | 0 | 0 | 0 | 0 | 0 | 0 | 0 | 0 | 0 | 0 | 0 | 0 | 0 | 0 | 0 | 0 | 0 | 0 | 0 | |
| | △ | 0 | 0 | 0 | 0 | 0 | 0 | 1 | 0 | 0 | 0 | 0 | 0 | 0 | 0 | 1 | 0 | 0 | 0 | 0 | 0 | 0 | 0 | 1 | |
| | Darker | 0 | 0 | 0 | 0 | 0 | 0 | 1 | 0 | 0 | 0 | 0 | 0 | 0 | 1 | 0 | 0 | 0 | 0 | 0 | 0 | 0 | 1 | 0 | |
| | △ | | | | | | | | | | | | | | | | | | | | | | | | |
| | ▽ | | | | | | | | | | | | | | | | | | | | | | | | |
| | Brighter | 1 | 1 | 1 | 1 | 1 | 0 | 1 | 1 | 1 | 1 | 1 | 1 | 0 | 1 | 1 | 1 | 1 | 1 | 1 | 1 | 0 | 1 | | |
| | ▽ | 1 | 1 | 1 | 1 | 1 | 1 | 0 | 1 | 1 | 1 | 1 | 1 | 1 | 0 | 1 | 1 | 1 | 1 | 1 | 1 | 1 | 0 | | |
| | White | 1 | 1 | 1 | 1 | 1 | 1 | 1 | 1 | 1 | 1 | 1 | 1 | 1 | 1 | 1 | 1 | 1 | 1 | 1 | 1 | 1 | 1 | | |

9.0 POWER SEQUENCE

To prevent a latch-up or DC operation of the LCD module, the power on sequence shall be as shown in below

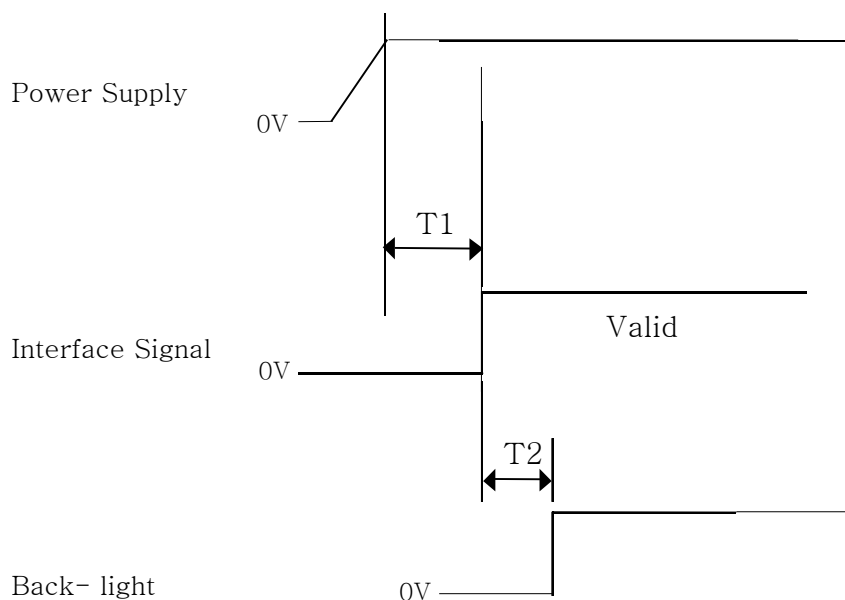

● $0 \leq T1 \leq 70 \text{ ms}$

● $200 \text{ ms} \leq T2$

Notes:

1. When the power supply VDD is 0V, keep the level of input signals on the low or keep high impedance.
2. Do not keep the interface signal high impedance when power is on.
3. Back Light must be turn on after power for logic and interface signal are valid.
4. The above power sequence should be satisfied at these case
 - .AC/DC power On/Off
 - .Mode Change (Resolution, frequency, timing, sleep mode, color depth change etc.)

If not to follow power sequence, there is a risk of abnormal display.

10.0 MECHANICAL CHARACTERISTICS

10.1 Dimensional Requirements

FIGURE 5 (located in Appendix) shows mechanical outlines for the model DV332X2M-NV0. Other parameters are shown in Table 8.

<Table 8. Dimensional Parameters>

| Parameter | Specification | Unit |
|---------------------|--|--------|
| Dimensional outline | 612.96(H) × 612.96(V) × 7.7(D) typ. | mm |
| Weight | 4.88 ± 0.1 | Kg |
| Active area | 596.16(H) × 596.16(V) | mm |
| Pixel pitch | 0.1035(H) x 0.3105(V) | mm |
| Number of pixels | 1920(H) × 1920(V) (1 pixel = R + G + B dots) | pixels |
| Back-light | E-LED (左右双侧入光) | |

10.2 Mounting

See FIGURE 5 . (shown in Appendix)

10.3 Anti-Glare and Polarizer Hardness.

The surface of the LCD has an anti-glare coating to minimize reflection and a coating to reduce scratching.

10.4 Light Leakage

There shall not be visible light from the back-lighting system around the edges of the screen as seen from a distance 50cm from the screen with an overhead light level of 350lux.

11.0 RELIABILITY TEST

The Reliability test items and its conditions are shown in below.

<Table 9 Reliability Test Parameters >

| No | Test Items | Conditions |
|----|---|---|
| 1 | High temperature storage test | Ta = 60 °C, 240 hrs |
| 2 | Low temperature storage test | Ta = -20 °C, 240 hrs |
| 3 | High temperature & high humidity operation test | Ta = 50 °C, 80%RH, 240hrs |
| 4 | High temperature operation test | Ta = 50 °C, 240hrs |
| 5 | Low temperature operation test | Ta = -5°C, 240hrs |
| 6 | Thermal shock | Ta = -20 °C ↔ 60 °C (0.5 hr), 100 cycle |
| 7 | Electro-static discharge test | Air : 150 pF, 330Ω, 15 KV Contact : 150 pF, 330Ω, 8 KV |
| 8 | Altitude test | Non Operating: 40000 ft, -10°C / 24 Hr, 25°C / 24 Hr, -10°C / 24 Hr |
| | | Operating: 15000 ft, 0°C / 24 Hr, 25°C / 24 Hr, 50°C / 24 Hr |

12.0 HANDLING & CAUTIONS

(1) Cautions when taking out the module

- Pick the pouch only, when taking out module from a shipping package.

(2) Cautions for handling the module

- As the electrostatic discharges may break the LCD module, handle the LCD module with care. Peel a protection sheet off from the LCD panel surface as slowly as possible.
- As the LCD panel and back - light element are made from fragile glass material, impulse and pressure to the LCD module should be avoided.
- As the surface of the polarizer is very soft and easily scratched, use a soft dry cloth without chemicals for cleaning.
- Do not pull the interface connector in or out while the LCD module is operating.
- Put the module display side down on a flat horizontal plane.
- Handle connectors and cables with care.

(3) Cautions for the operation

- When the module is operating, do not lose CLK, ENAB signals. If any one of these signals is lost, the LCD panel would be damaged.
- Obey the supply voltage sequence. If wrong sequence is applied, the module would be damaged.

(4) Cautions for the atmosphere

- Dew drop atmosphere should be avoided.
- Do not store and/or operate the LCD module in a high temperature and/or humidity atmosphere. Storage in an electro-conductive polymer packing pouch and under relatively low temperature atmosphere is recommended.

(5) Cautions for the module characteristics

- Do not apply fixed pattern data signal to the LCD module at product aging.
- Applying fixed pattern for a long time may cause image sticking.

(6) Other cautions

- Do not disassemble and/or re-assemble LCD module.
- Do not re-adjust variable resistor or switch etc.
- When returning the module for repair or etc., Please pack the module not to be broken. We recommend to use the original shipping packages.

13.0 PRODUCT SERIAL NUMBER

| | | | |
|---|----------------------|--|---|
| DP/N XXXXXX | DV332X2M-NV0 | B4 |  |
| XXXX | XXXXXXXXXXXXXXXXXXXX | |  |
|  | REV XXX |  |  |
| XX-XXXXXX-XXXXX-XXX-XXXX | | | MADE IN CHINA |



- 1. Control Number
- 2. Rank / Grade
- 3. Line Classification
- 4. Year (2001 : 01, 2002 : 02, ...)

- 5. Month (1,2,3, ... , 9, X, Y, Z)
- 6. Internal Use
- 7. Serial Number

14.0 Packing

14.1 Packing Order

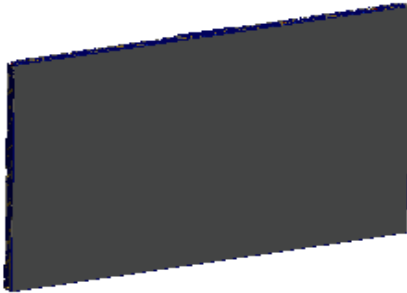

LCD Module

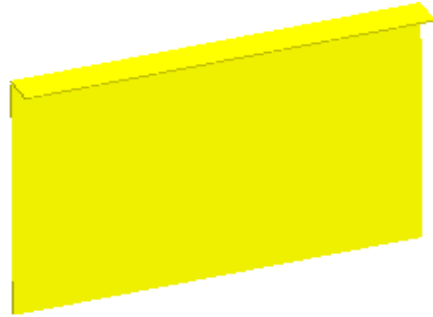

Put LCD MDL in the PE bag.

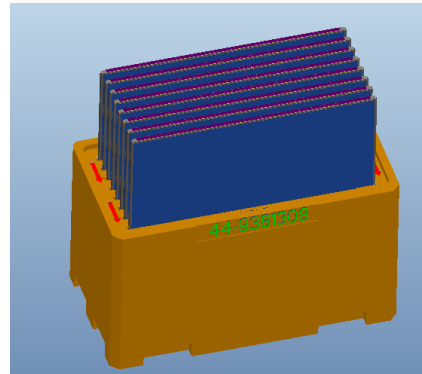

Put 8LCD MDL in the EPS BOX.

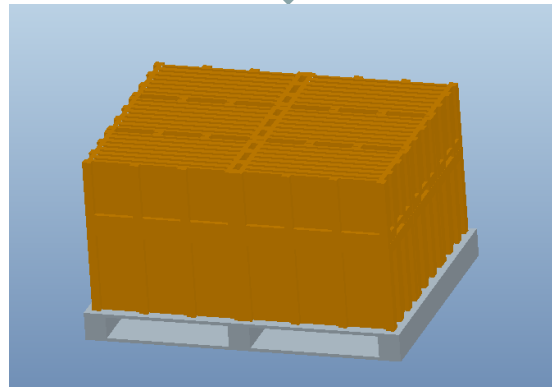

Put 6 EPS BOX on the pallet.

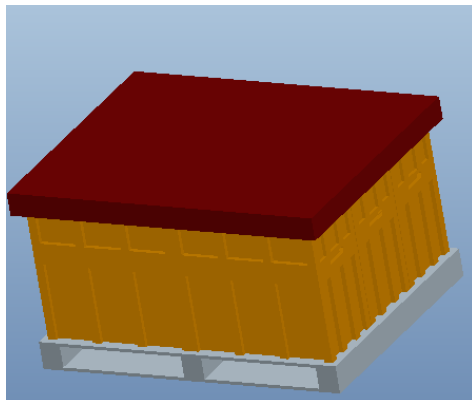

Put the Top-cover on the Box (48ea MDLs per pallet) and Pack with 4 packing belts.

14.3 Packing Specification and Note

| Item | Specification | | | Remark |
|----------------|---------------|---------------------------------|-------------|-------------------------|
| | Q'ty | Dimension(mm) | Weight (kg) | |
| MDL | 1 | 612.96(H) × 612.96 (V) × 7.7(D) | 5.2 | - |
| Box | 1 | 716(L)*371(W)*735(H)mm | 2.59 | without Panel & cushion |
| Packing Box | 8pcs/Box | 716(L)*371(W)*735(H)mm | 44 | with panel & cushion |
| Pallet | 1 | 1445(L)×1140(W)×130(H)mm | 25 | - |
| Packing Pallet | 6Box/Pallet | 1445(H)*1140(W)*853(H)mm | 289 | - |

14.3 Box label

- Label Size : 108 mm (L) × 56 mm (W)

- Contents

Model : DV332X2M-NV0

Q`ty : Module 8 Q`ty in one box

Serial No. : Box Serial No Date : Packing Date

FG Code : FG Code of Product

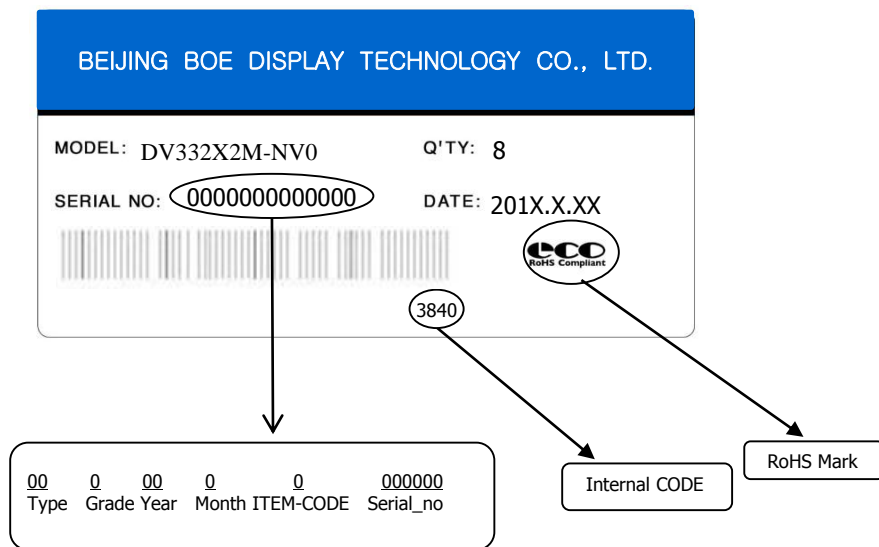

15.0 APPENDIX

Figure 1. Measurement Set Up

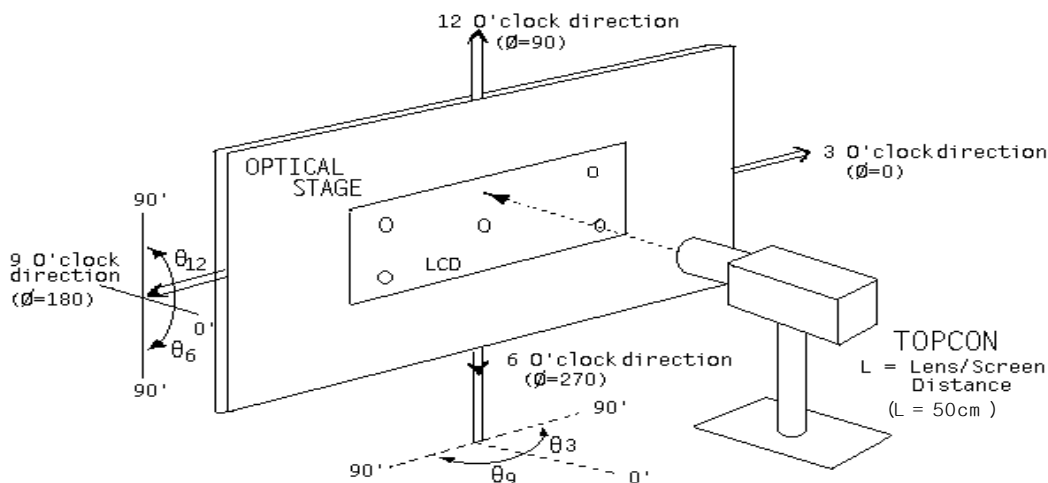

Figure 2. White Luminance and Uniformity Measurement Locations (9 points)

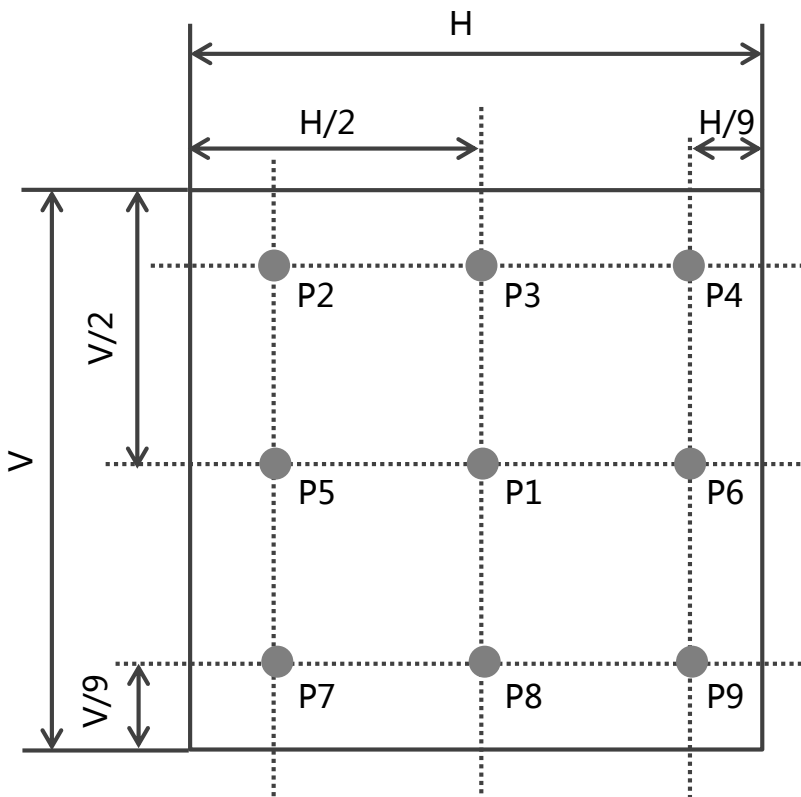
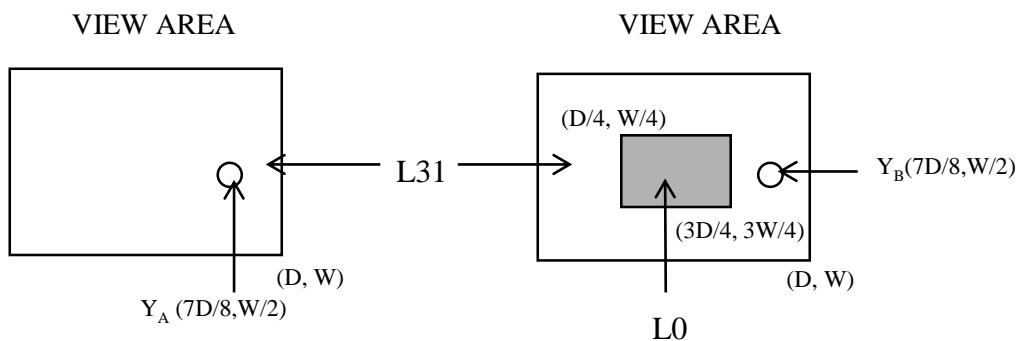

Figure 3. Response Time Testing



Figure 4. Cross Modulation Test Description



$$\text{Cross-Talk (\%)} = \left| \frac{Y_B - Y_A}{Y_A} \right| \times 100$$

Where: Y_A = Initial luminance of measured area (cd/m²)

Y_B = Subsequent luminance of measured area (cd/m²)

The location measured will be exactly the same in both patterns

Figure 5. TFT-LCD Module Outline Dimensions (Front view)

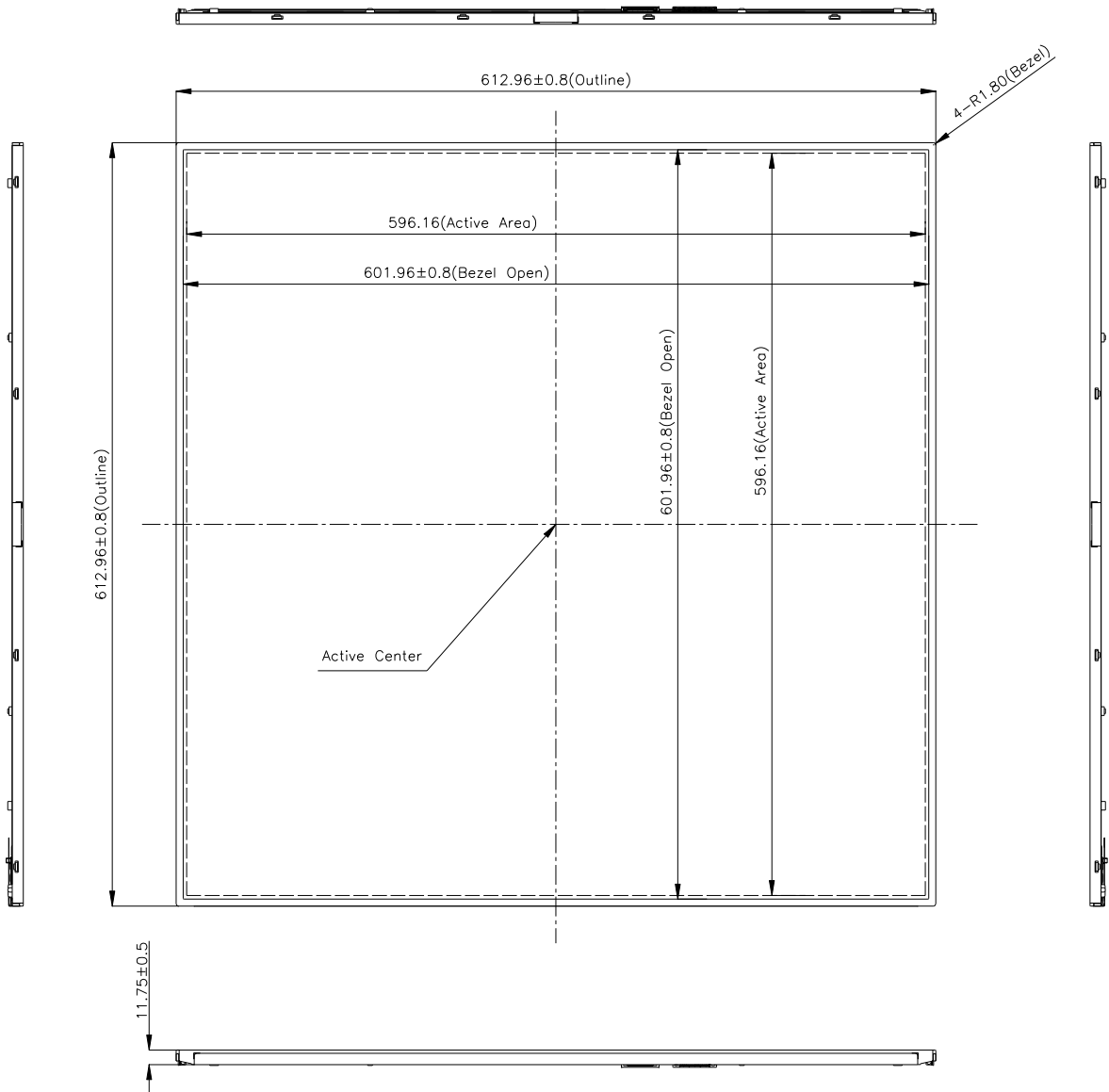
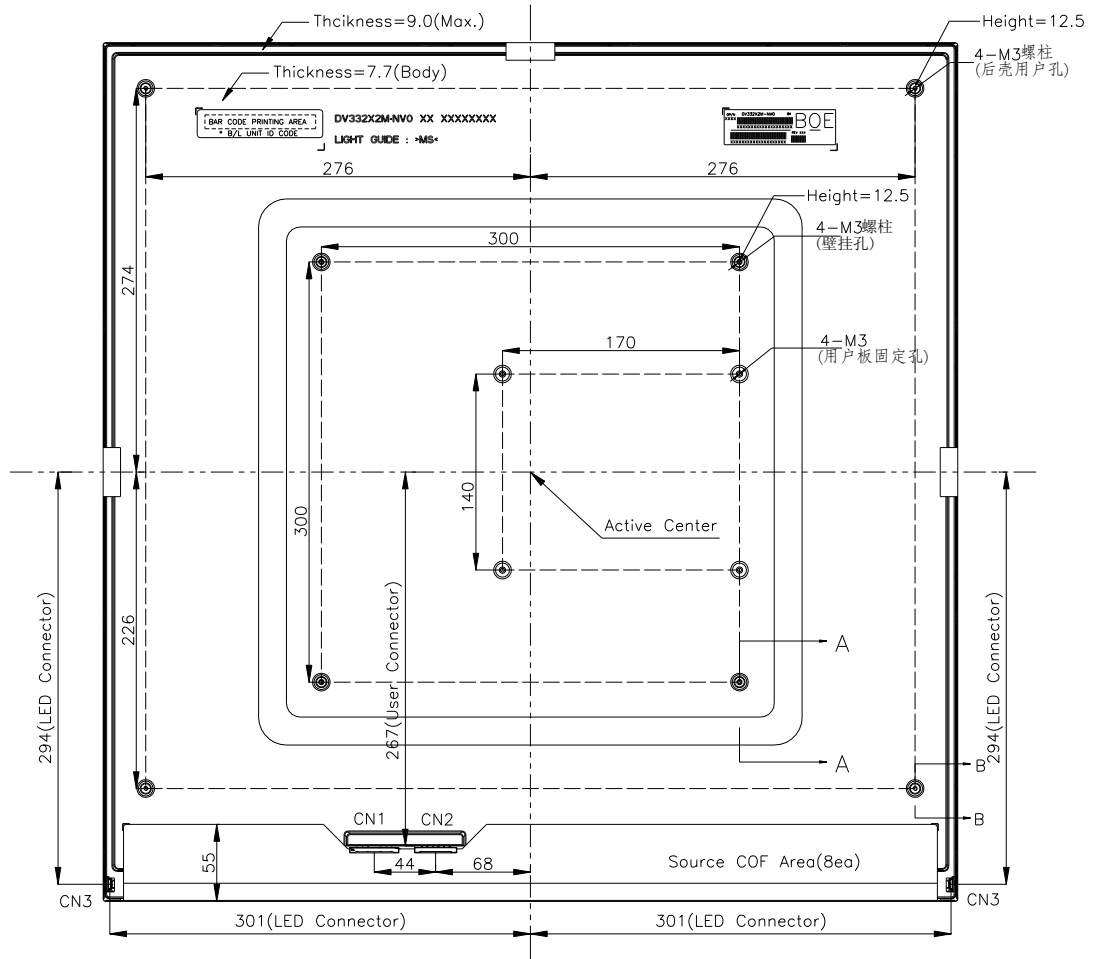

Figure 6. TFT-LCD Module Outline Dimensions (Rear view)



NOTE:

1. CN1: 51pin(Lvds+5V Input interface)
2. CN2: 41pin(Lvds Input interface)
3. CN3: 6pin(3707K-Q06N-08X)
4. The COF area is weak and sensitive, so please don't press the COF area
5. Weight: 4.88±0.1kg
6. Thickness Tolerance: ±0.5mm
6. Tilt and partial disposition tolerance of display area as following
 - (1) Y-direction: A-B≤1.4mm
 - (2) X-direction: C-D≤1.4mm

