

FEATURES

1. Continuous short-circuit protection
2. No-load input current as low as 8mA
3. Operating ambient temperature range: -40°C to +105°C
4. High efficiency up to 85%
5. Compact SMD package
6. I/O isolation test voltage: 3k VDC
7. Industry standard pin-out



**3 years
Warranty**

Selection Guide

Part No.	Input Voltage (VDC)	Output		Full Load Efficiency (%) Min./Typ.	Capacitive Load (µF) Max.
	Nominal (Range)	Voltage (VDC)	Current (mA) Max./Min.		
F0303XT-1WR3	3.3 (2.97-3.63)	3.3	303/30	73/77	2400
F0305XT-1WR3		5	200/20	78/82	2400
F0309XT-1WR3		9	111/11	80/84	1000
F0312XT-1WR3		12	83/8	80/84	560
F0315XT-1WR3		15	67/7	80/84	560
F0324XT-1WR3		24	42/4	80/84	220
F0503XT-1WR3	5 (4.5-5.5)	3.3	303/30	70/74	2400
F0505XT-1WR3		5	200/20	78/82	2400
F0509XT-1WR3		9	111/12	79/83	1000
F0512XT-1WR3		12	84/9	79/83	560
F0515XT-1WR3		15	67/7	79/83	560
F0524XT-1WR3		24	42/4	81/85	220
F0503XT-1WR3-TR	5 (4.5-5.5)	3.3	303/30	70/74	2400
F0505XT-1WR3-TR		5	200/20	78/82	2400
F0509XT-1WR3-TR		9	111/12	79/83	1000
F0512XT-1WR3-TR		12	84/9	79/83	560
F0515XT-1WR3-TR		15	67/7	79/83	560
F0524XT-1WR3-TR		24	42/4	81/85	220
F1203XT-1WR3	12 (10.8-13.2)	3.3	303/30	72/76	2400
F1205XT-1WR3 (-TR)		5	200/20	78/82	2400
F1209XT-1WR3 (-TR)		9	111/12	79/83	1000
F1212XT-1WR3 (-TR)		12	84/9	79/83	560
F1215XT-1WR3 (-TR)		15	67/7	79/83	560
F1224XT-1WR3 (-TR)		24	42/4	81/85	220
F1505XT-1WR3 (-TR)	15 (13.5-16.5)	5	200/20	78/82	2400
F1509XT-1WR3		9	111/12	78/82	1000
F1515XT-1WR3 (-TR)		15	67/7	79/83	560
F2403XT-1WR3	24 (21.6-26.4)	3.3	303/30	72/76	2400
F2405XT-1WR3 (-TR)		5	200/20	74/80	2400
F2409XT-1WR3 (-TR)		9	111/12	74/80	1000

F2412XT-1WR3 (-TR)		12	84/9	74/80	560
F2415XT-1WR3 (-TR)		15	67/7	74/80	560
F2424XT-1WR3 (-TR)		24	42/4	74/80	220

Input Specifications

Item	Operating Conditions		Min.	Typ.	Max.	Unit
Input Current (full load / no-load)	3.3VDC input	3.3VDC output	–	394/12	416/–	mA
		5VDC output	–	370/12	389/–	
		9VDC/12VDC/15VDC/24VDC output	–	361/12	379/–	
	5VDC input	3.3VDC/5VDC output	–	270/8	286/–	
		9VDC/12VDC output	–	241/12	254/–	
		15VDC/24VDC output	–	241/18	254/–	
	12VDC input	3.3VDC	–	110/8	116/–	
		5VDC output	–	102/8	107/–	
		9VDC/12VDC/15VDC output	–	101/8	106/–	
		24VDC output	–	99/8	103/–	
	15VDC input	5VDC/9VDC output	–	82/8	86/–	
		15VDC output	–	81/8	85/–	
	24VDC input	3.3VDC output	–	55/8	58/–	
		5VDC output	–	53/8	57/–	
		9VDC/12VDC/15VDC output	–	51/8	55/–	
		24VDC output	–	53/8	57/–	
Reflected Ripple Current*	3.3VDC input	–	30	–	VDC	
	Other input	–	15	–		
Surge Voltage(1sec. max.)	3.3VDC input	-0.7	–	5	VDC	
	5VDC input	-0.7	–	9		
	12VDC input	-0.7	–	18		
	15VDC input	-0.7	–	21		
	24VDC input	-0.7	–	30		
Input Filter			Capacitance filter			
Hot Plug			Unavailable			

Note: * Refer to DC-DC Converter Application Notes for detailed description of reflected ripple current test method.

Output Specifications

Item	Operating Conditions		Min.	Typ.	Max.	Unit	
Voltage Accuracy			See output regulation curves (Fig. 1)				
Linear Regulation	Input voltage change: ±1%		3.3VDC output	–	–	±1.5	–
			Others	–	–	±1.2	
Load Regulation	10%-100% load	3.3VDC input	3.3VDC output	–	15	20	%
			5VDC output	–	10	15	
			9VDC/12VDC/15VDC output	–	8	15	
			24VDC output	–	6	15	
		5VDC input	3.3VDC output	–	15	20	
			5VDC output	–	10	15	
			9VDC output	–	8	10	
			12VDC output	–	7	10	
			15VDC output	–	6	10	
			24VDC output	–	5	10	
Load Regulation	10%-100% load	12VDC/15VDC/24VDC input	3.3VDC output	–	8	20	%
			5VDC output	–	5	15	
			9VDC output	–	3	10	

			12VDC output	-	3	10	
			15VDC output	-	3	10	
			24VDC output	-	2	10	
Ripple & Noise*	20MHz bandwidth	3.3VDC input		-	50	100	mVp-p
		5VDC/12VDC/15VDC/24VDC input	Other output	-	30	75	
			24VDC output	-	50	100	
Temperature Coefficient	Full load		-	±0.02	--		%/°C
Short-Circuit Protection	Continuous, self-recovery						

Note:* The "parallel cable" method is used for Ripple and Noise test, please refer to DC-DC Converter Application Notes for specific information.

General Specifications

Item	Operating Conditions		Min.	Typ.	Max.	Unit	
Isolation	Input-output electric strength test for 1 minute with a leakage current of 1mA max.		3000	-	-	VDC	
Insulation Resistance	Input-output resistance at 500VDC		1000	-	-	MΩ	
Isolation Capacitance	Input-output capacitance at 100kHz/0.1V		-	20	-	pF	
Operating Temperature	3.3VDC input	Derating when operating temperature ≥ 85°C, (see Fig. 2)	-40	-	105	°C	
	Other input	Derating when operating temperature ≥ 100°C, (see Fig. 2)					
Storage Temperature			-55	-	125		
Case Temperature Rise	Ta=25°C	5VDC input	3.3VDC output	-	25		-
			Other output	-	15	-	
		Other input		-	25	-	
Storage Humidity	Non-condensing	5VDC input		-	-	95	%RH
		Other input		5	-	95	
Reflow Soldering Temperature*			Peak temp. ≤ 245°C, maximum duration time ≤ 60s over 217°C				
Vibration	3.3VDC/12VDC/15VDC/24VDC input		10-150Hz, 5G, 0.75mm. along X, Y and Z				
Switching Frequency	Full load, nominal input voltage	3.3VDC input		-	220	-	kHz
		5VDC input		-	270	-	
		12VDC/15VDC/24VDC input		-	260	-	
MTBF	MIL-HDBK-217F@25°C		3500	--	-	hours	
Moisture Sensitivity Level (MSL)	IPC/JEDEC J-STD-020D.1		Level 1				

Note: *Please refer to IPC/JEDEC J-STD-020D.1.

Mechanical Specifications

Case Material	Black plastic; flame-retardant and heat-resistant (UL94V-0)
Dimensions	13.20 x 11.40 x 7.25 mm
Weight	1.4g(Typ.)
Cooling Method	Free air convection

Electromagnetic Compatibility (EMC)

Emissions	CE	CISPR32/EN55032 CLASS B			
	RE	CISPR32/EN55032 CLASS B			
Immunity	ESD	5VDC input	IEC/EN61000-4-2	Air ±8kV, Contact ±4kV	perf. Criteria B
		other input	IEC/EN61000-4-2	Air ±8kV, Contact ±6kV	perf. Criteria B

Note: Refer to Fig. 4 for recommended circuit test.

Typical Characteristic Curves

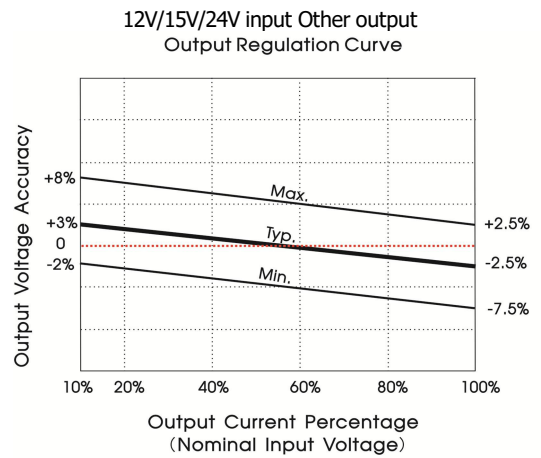
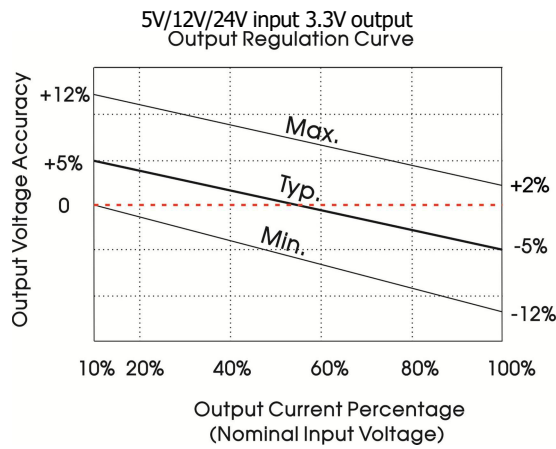
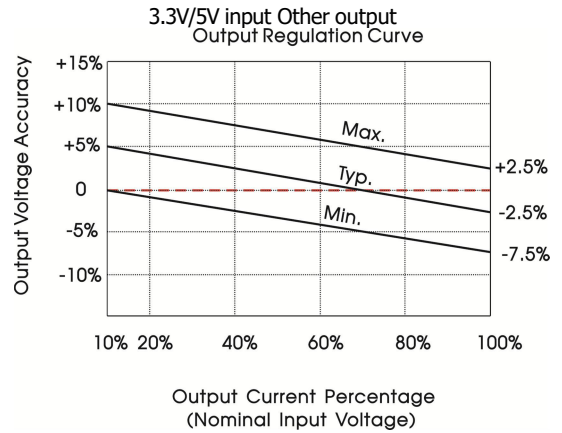
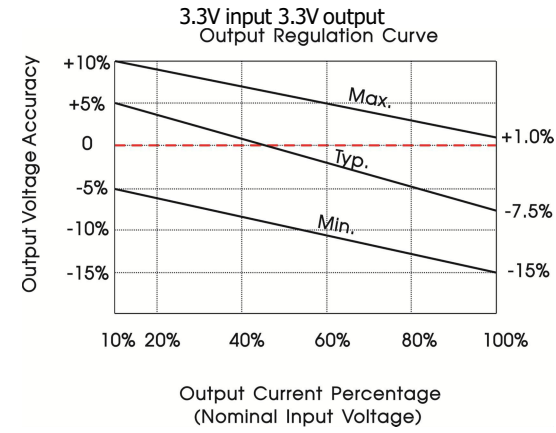

Fig. 1

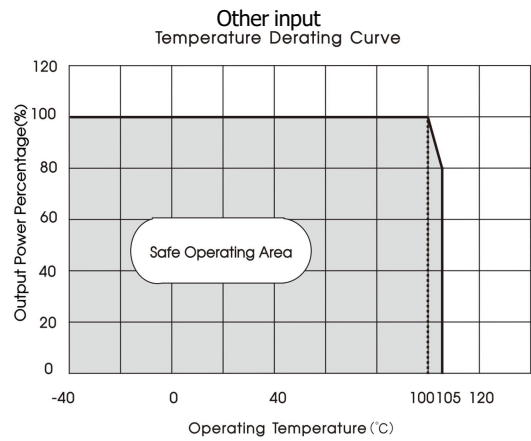
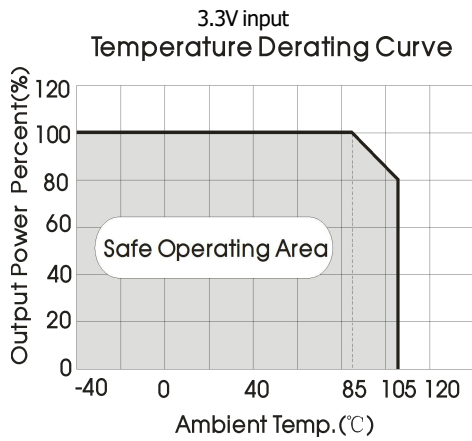
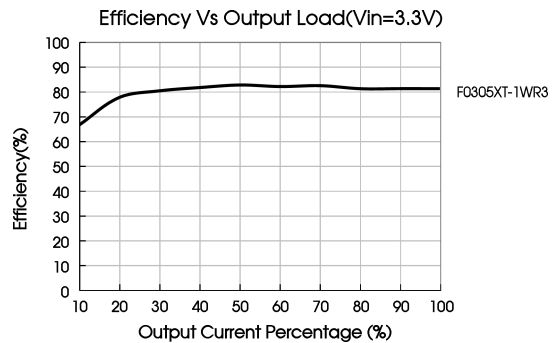
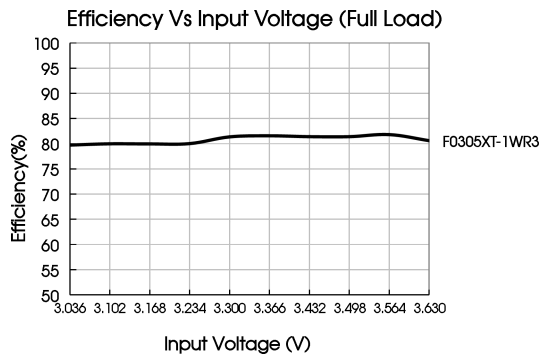
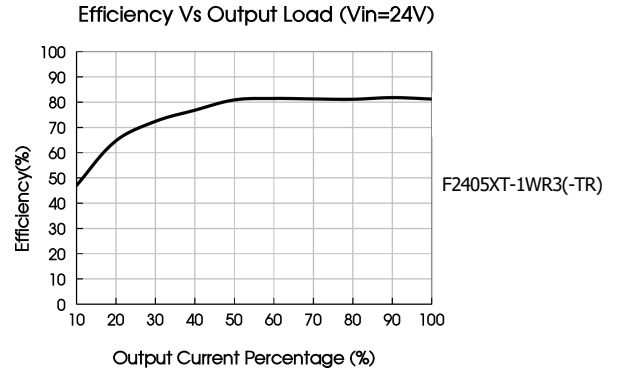
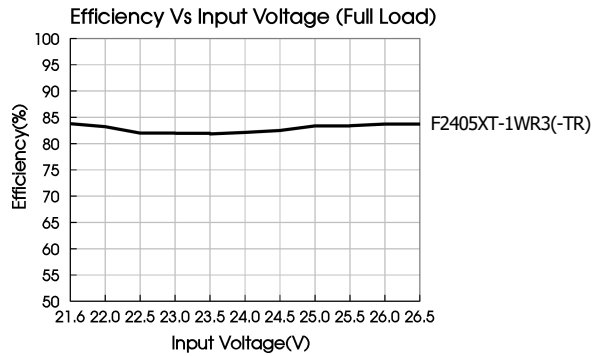
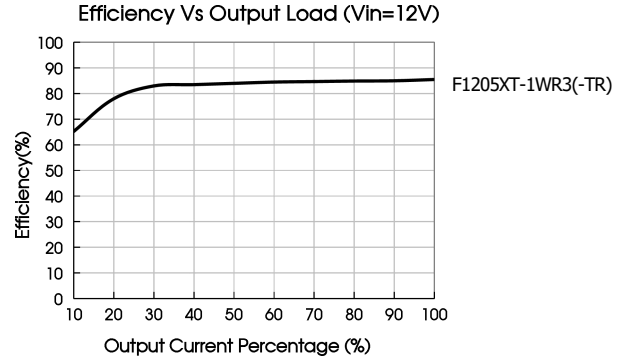
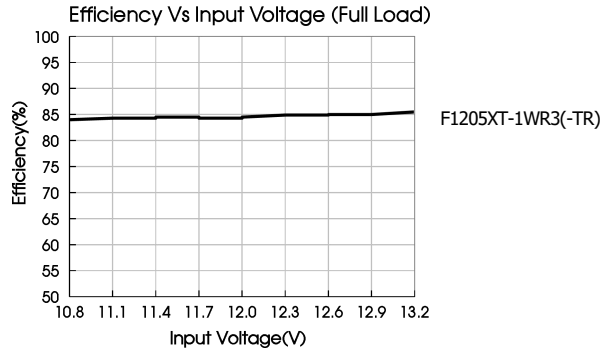
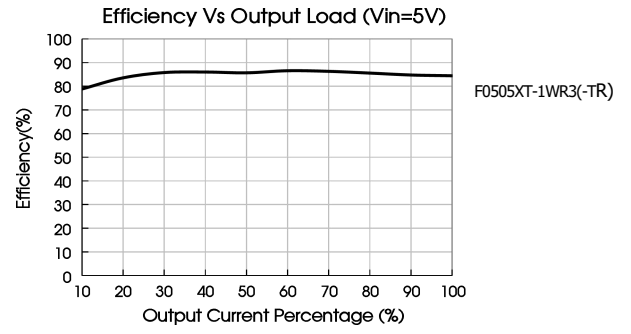
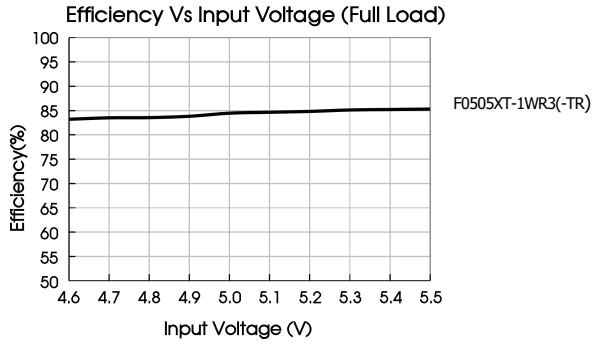

Fig. 2





Design Reference

1. Typical application

Input and/or output ripple can be further reduced, by connecting a filter capacitor from the input and/or output terminals to ground as shown in Fig. 3. Choosing suitable filter capacitor values is very important for a smooth operation of the modules, particularly to avoid start-up problems caused by capacitor values that are too high. For recommended input and output capacitor values refer to Table 1.

Table2:Recommended input and output capacitor values

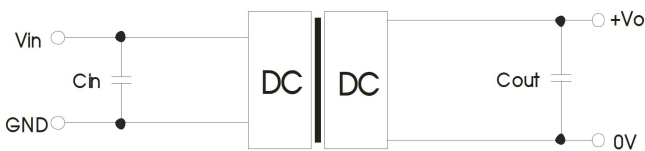

Fig. 3

V_{in}	C_{in}	V_o	C_{out}
3.3VDC	4.7 μ F/16V	3.3VDC/5VDC	10 μ F/16V
5VDC	4.7 μ F/16V	9VDC	2.2 μ F/16V
12VDC	2.2 μ F/25V	12VDC	2.2 μ F/25V
15VDC	2.2 μ F/25V	15VDC	1 μ F/25V
24VDC	1 μ F/50V	24VDC	1 μ F/50V

2. EMC compliance circuit

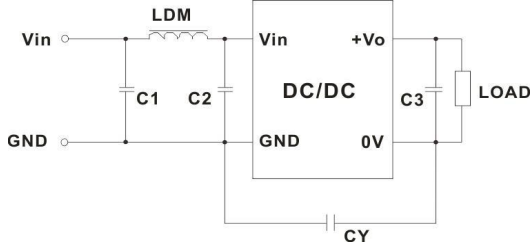

Fig. 4

Table2: EMC recommended circuit value table

Input voltage	3.3VDC Input	5VDC Input	12/15/24VDC Input	
Output voltage	-	3.3/5/9VDC	12/15/24VDC	
EMI	C1, C2	4.7μF/16V	4.7μF/25V	4.7μF/50V
	CY	270pF/4kV	100pF/4kV	1000pF/4kV
	C3	Refer to the Cout in table 1		
	LDM	6.8μH		

Note: In the case of actual use, the requirements for EMI are high, it is subject to CY.

Dimensions and Recommended Layout

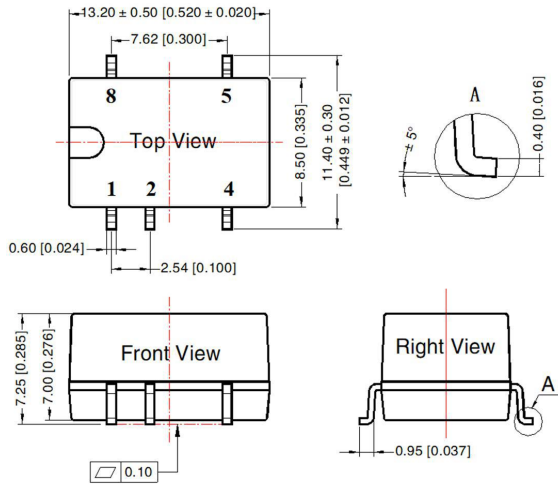

Note:
 Unit: mm[inch]
 Pin section tolerances: ± 0.10 [± 0.004]
 General tolerances: ± 0.25 [± 0.010]

THIRD ANGLE PROJECTION

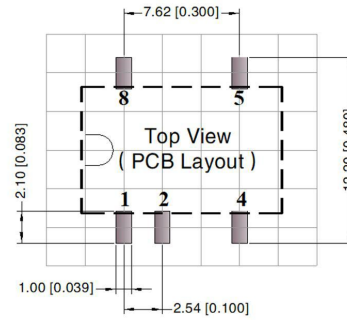

Note: Grid 2.54*2.54mm

Pin-Out	
Pin	Mark
1	GND
2	Vin
4	0V
5	+Vo
8	NC

NC: Pin to be isolated from circuitry

Tape and Reel Info

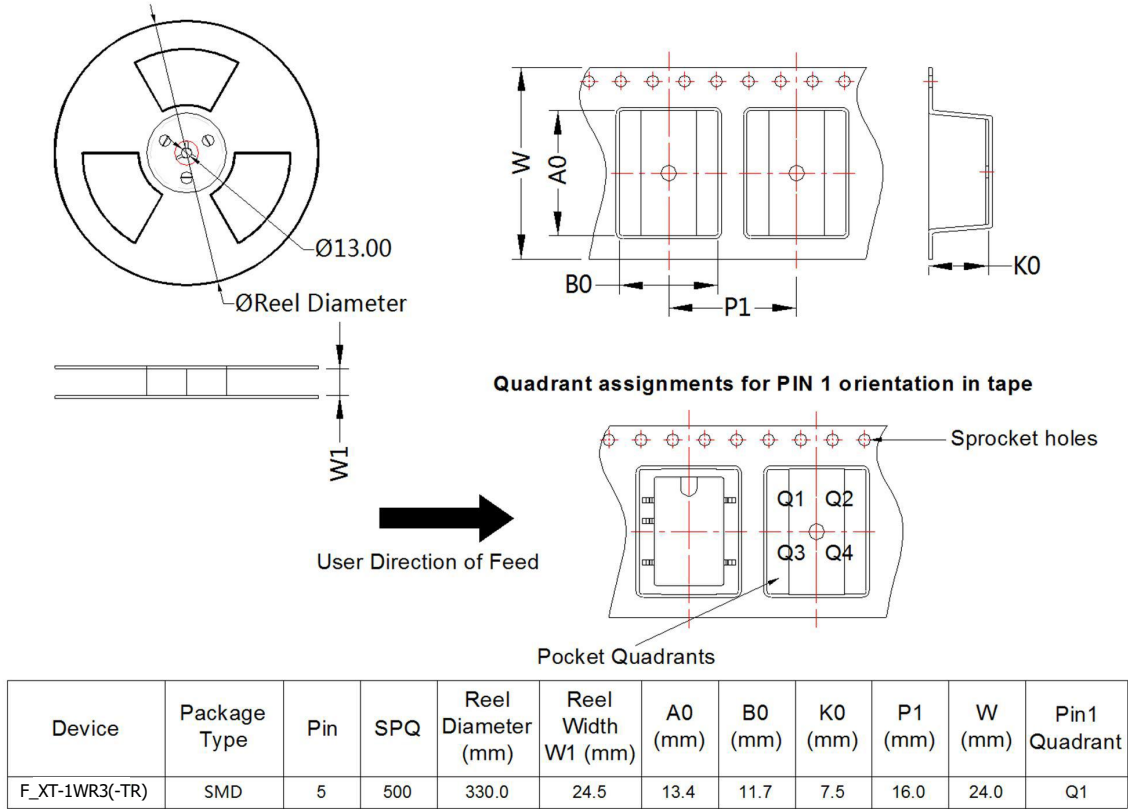

Notes & Instructions

1. If the product works under the minimum required load, it cannot guarantee that the performance of the product complies with all the performance indicators in this manual;
2. The maximum capacitive load is tested under the input voltage range and full load condition;
3. Unless otherwise stated, all indexes in this manual are measured at Ta=25°C, humidity <75%RH, nominal input voltage and rated output load;
4. All index testing methods in this manual are based on the enterprise standards of the company;
5. Our company can provide product customization, specific needs can directly contact our technical staff;

NORPAS-POWER TECHNOLOGY CO., LTD.

www.norpas-power.com Mail: info@norpas-power.com

Specifications can be changed without notice! Make sure you are using the latest documentation, downloadable at www.norpas-power.com

REV:07/2024