

Latch, High Voltage Hall-Effect Switch IC

1 Product Description

The MT836X family is produced by BCD technology with both high performance and high reliability. The Hall IC internally includes an on-chip Hall voltage generator, a voltage regulator for operation with supply voltage of 3.8V to 60V, temperature compensation circuitry, small-signal amplifier, Hall IC with dynamic offset cancellation system, Schmitt trigger and an open collector output. It also includes a clamp diode at output and reversed power supply protection enhances the robustness of Hall IC.

The Hall IC designed to respond to alternating north and south poles. While the magnetic flux density(B) is larger than operating point (BOP), the output will be turned on (Low), the output is held until the magnetic flux density(B) is lower than releasing point (BRP), then turn off (High).

The MT836X family provides a variety of packages to customers: SOT-23/SOT-89-3L/SOT-23 (Thin Outline) for surface mount and flat TO-92 for through-hole mount. All packages are RoHS compliant.

2 Features

- AEC-Q100 Automotive Qualified
MT836XAT & MT836XET & MT836XA
- BCD Technology
- Latch Switch
- 3.8~60V Operating Vcc Range
- -40°C~150°C Operating Temperature
- Package Option:
Flat TO-92 / Flat TO-92 (Radial Lead) / SOT-23 / SOT-23 (Thin Outline) / SOT-89-3L
- Magnetic Sensitivity Option:
MT8361 (BOP=50Gs, BRP=-50Gs)
MT8362 (BOP=20Gs, BRP=-20Gs)
- Open-Drain Output
- -20V Reversed Power Supply Protection
- Output Limiting Current Protection
- RoHS Compliant: (EU)2015/863

3 Product Overview of MT836X

Part No.	Description
MT836XA	Flat TO-92, bulk packaging (1000pcs/bag)
MT836XA-T	Flat TO-92, radial lead, bulk packaging (1000pcs/bag)
MT836XAT	SOT-23, tape & reel (3000pcs/bag)
MT836XET	SOT-23 (Thin Outline), tape & reel (3000pcs/bag)
MT836XBT	SOT-89-3L, tape & reel (1000pcs/bag)

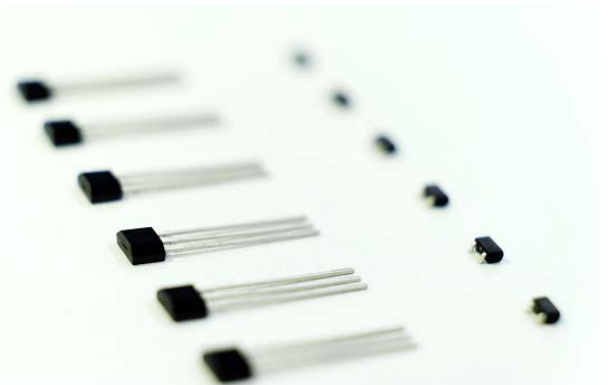

4 Applications

- Automotive, Home appliances,
- Industrial
- Speed Detection
- Magnetic Encoder
- Brushless DC Motor Communication

5. Pin Configuration and Functions

	Vcc	Out	GND
SOT-23	1	2	3
SOT-23 (Thin Outline)	1	2	3
Flat TO-92 (Radial Lead)	1	3	2
Flat TO-92	1	3	2
SOT-89-3L	1	3	2
Description	Power	Output Open-Drain	Ground

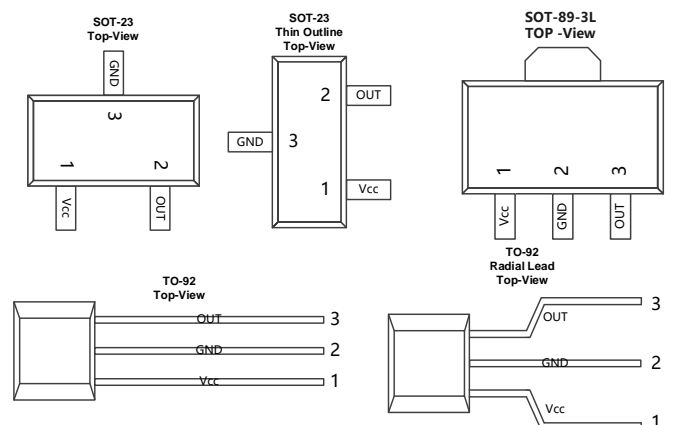

Figure.1 Pin Configuration & Functions

Table of Contents

1	Product Description.....	1
2	Features.....	1
3	Product Overview of MT836X	1
4	Applications.....	1
5	Pin Configuration and Functions.....	1
6	Definition of Switching Function.....	3
7	Function Description.....	3
8	Feature Description.....	3
9	Functional Block Diagram.....	4
10	Electrical and Magnetic Characteristics.....	4
	10.1 Absolute Maximum Ratings.....	4
	10.2 Electrical Specifications.....	5
	10.3 Magnetic Characteristics.....	5
	10.4 ESD Ratings.....	5
	10.5 Characteristic Performance.....	6
	10.6 Typical Output Waveform.....	7
11	Typical Application Circuit.....	7
12	Package Material Information.....	8
	12.1 SOT-23 Package Information.....	8
	12.2 SOT-23 (Thin Outline) Package Information.....	9
	12.3 SOT-89-3L Package Information.....	10
	12.4 Flat TO-92 Package Information.....	11
	12.5 Flat TO-92 (Radial Lead) Package Information.....	12
13	Copy Rights and Disclaimer.....	13

Reversion History

1	Originally Version	
2	1.1 Version	Update SOT-23 (Thin Outline) Package
3	1.2 Version	Update MT8362 Series
4	1.3 Version	Update Flat TO-92 (Radial Lead) Package
5	1.4 Version	Update AEC-Q100 Automotive on MT836XAT Update RoHS compliant to (EU)2015/863
6	1.5 Version	Update AEC-Q100 Logo Update Copy Rights and Disclaimer
7	1.6 Version	Update AEC-Q100 Automotive on MT836XET
8	1.7 Version	Update the marking spec of SOT-23 & SOT-23 (Thin Outline)
9	1.8 Version	Update the Logo of MagnTek
10	1.9 Version	Update SOT-89-3L Package Outline
11	2.0 Version	Update AEC-Q100 Automotive on MT836XA
12	2.1 Version	Update SOT-23 (Thin Outline) & SOT-23-3L Package Outline
13	2.2 Version	Update TO-92S Package Outline

6 Definition of Switching Function

Figure.2 & Figure.3 shows the device functionality and hysteresis

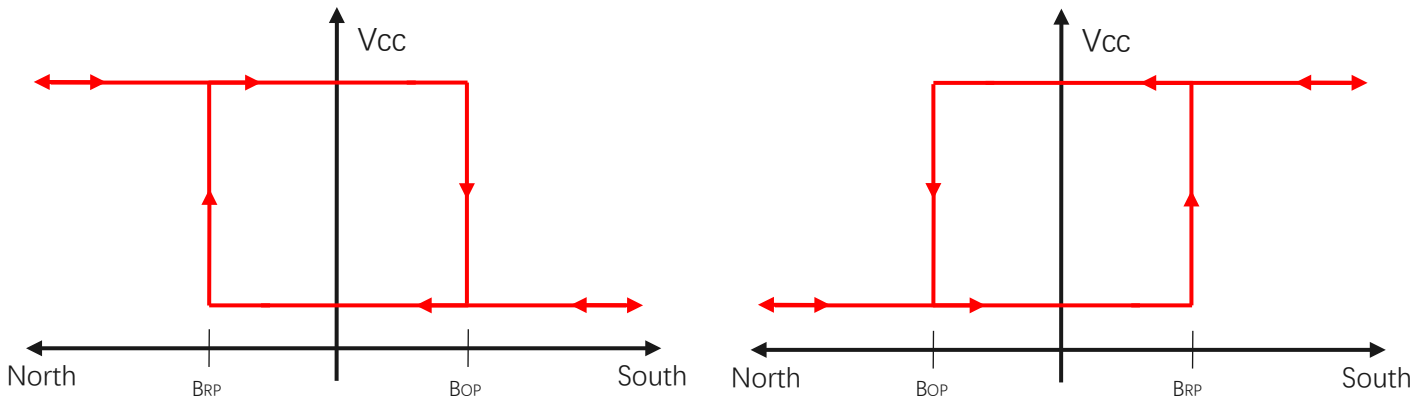

Figure.2 Switching Function of Flat TO-92 & SOT-89-3L & SOT-23 (Thin Outline)

Figure.3 Switching Function of SOT-23

7 Function Description

B_{OP}: Operating Point, Magnetic flux density applied on the branded side of the package which turns the output driver ON ($V_{OUT}=Low$)

B_{RP}: Releasing Point, Magnetic flux density applied on the branded side of the package which turns the output driver OFF ($V_{OUT}=High$)

B_{HYST}: Hysteresis Window, $|B_{OP} - B_{RP}|$

Devices that have a lower magnetic threshold ($V_{OUT}=High$) detect magnets at a farther distance. Higher thresholds ($V_{OUT}=Low$) generally require a closer distance or larger magnet.

8 Feature Description

The MT836X device is sensitive to the magnetic field component that is perpendicular to the top of the package

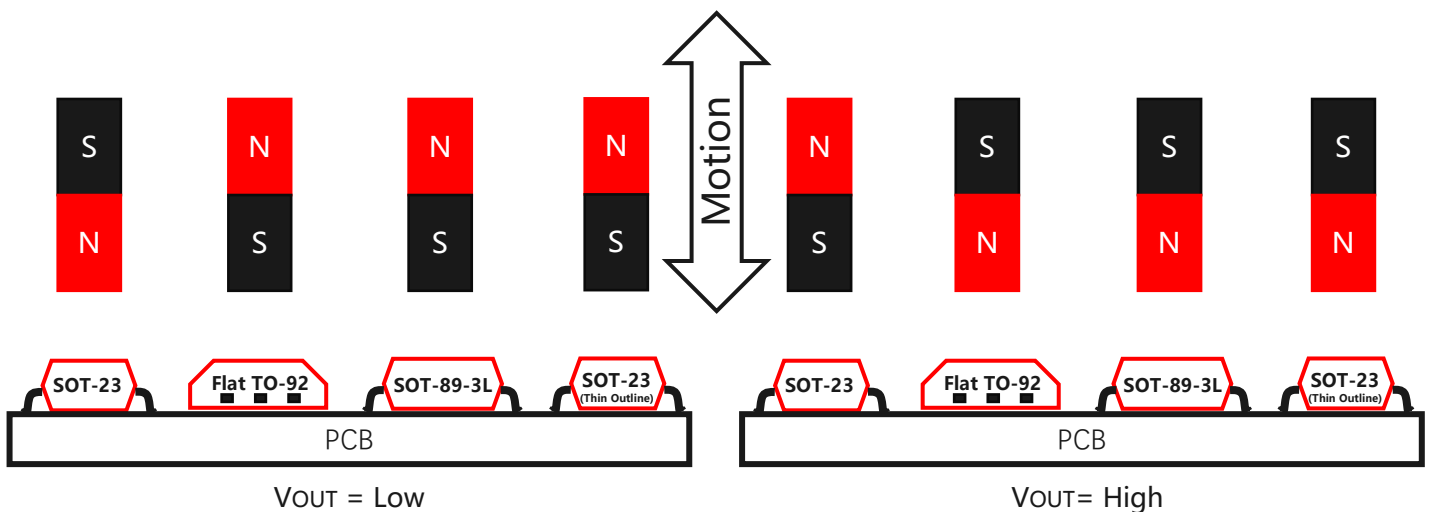

Figure.4 Flux Direction Polarity

9 Functional Block Diagram

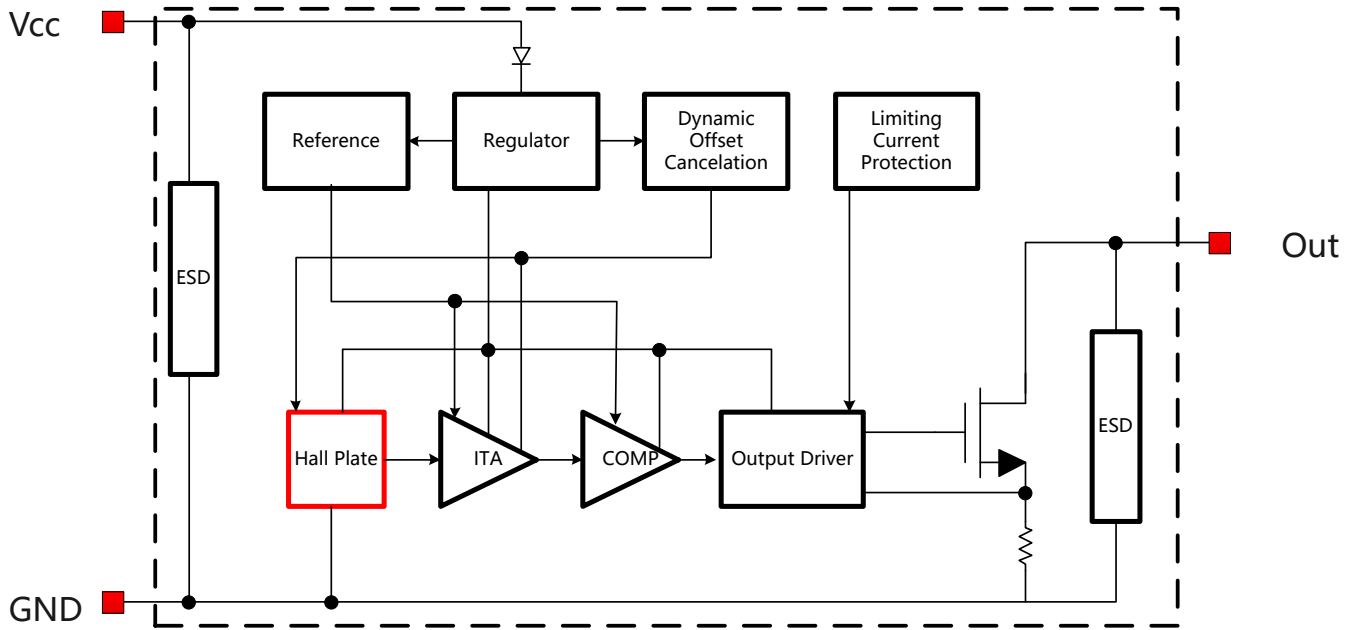

Figure.5 Functional Block Diagram

10 Electrical and Magnetic Characteristics

10.1 Absolute Maximum Ratings

Absolute maximum ratings are limited values to be applied individually, and beyond which the serviceability of the circuit may be impaired. Functional operability is not necessarily implied. Exposure to absolute maximum rating conditions for an extended period of time may affect device reliability.

Symbol	Parameters	Min	Max	Units
VCC	Supply Voltage	-	65	V
VRCC	Reverse Battery Voltage	-20	-	V
VOUT	Output Voltage	-	65	V
IOUT	Continuous Output Current	-	40	mA
TA	Operating Ambient Temperature	-40	150	°C
TS	Storage Temperature	-50	150	°C
TJ	Junction Temperature	-	165	°C
B	Magnetic Flux Density	No Limit		Gs

10.2 Electrical Specifications

At $T_A = -40 \sim 150 \text{ }^\circ\text{C}$, $V_{CC} = 3.8\text{V} \sim 60\text{V}$ (unless otherwise specified)

Symbol	Parameters	Test Condition	Min	Typ	Max	Unit
V _{CC}	Supply Voltage	Operating	3.8	-	60	V
I _{CC}	Supply Current	B < B _{RP}	-	4	6	mA
I _{OCP}	Short Circuit Protection Current	B > B _{OP} , V _{OUT} = V _{CC}	-	50	-	mA
V _{DSON}	Output Saturation Voltage	I _{OUT} = 15mA, B > B _{OP}	-	-	0.4	V
I _{OFF}	Output Leakage Current	V _{OUT} = 60V	-	-	10	uA
T _R	Output Rise Time	R _L = 1KOhm, C _L = 20pF	-	-	1.0	us
T _F	Output Fall Time	R _L = 1KOhm, C _L = 20pF	-	-	1.0	us
T _{PO}	Power on Time	dV _{CC} /dt > 5V/uS B > B _{OP(MAX)}	-	-	10	us
F _C	Chopping Frequency		-	800	-	KHz
F _S	Sampling Frequency		-	200	-	KHz
R _{TH}	Thermal Resistance of SOT-23		-	301	-	°C/W
	Thermal Resistance of SOT-23 (Thin Outline)		-	301	-	°C/W
	Thermal Resistance of Flat TO-92		-	230	-	°C/W
	Thermal Resistance of SOT-89-3L		-	250	-	°C/W

10.3 Magnetic Characteristics

At $V_{CC} = 3.8\text{V} \sim 60\text{V}$ (unless otherwise specified)

Part No.	Symbol	Min	Typ	Max	Unit
MT8361 Series	B _{OP} , T _A = 25°C	35	50	65	Gs
	B _{RP} , T _A = 25°C	-65	-50	-35	Gs
	B _{HYST} , T _A = 25°C	70	100	130	Gs
MT8362 Series	B _{OP} , T _A = 25°C	10	20	30	Gs
	B _{RP} , T _A = 25°C	-30	-20	-10	Gs
	B _{HYST} , T _A = 25°C	20	40	60	Gs

10.4 ESD Ratings

Symbol	Reference	Values	Unit
V _{ESD}	Human-body model (HBM)	AEC-Q100-002	Class II Grade
	Charged-device model (CDM)	AEC-Q100-011	Class C6 Grade

10.5 Characteristic Performance

At $V_{CC}=5V$

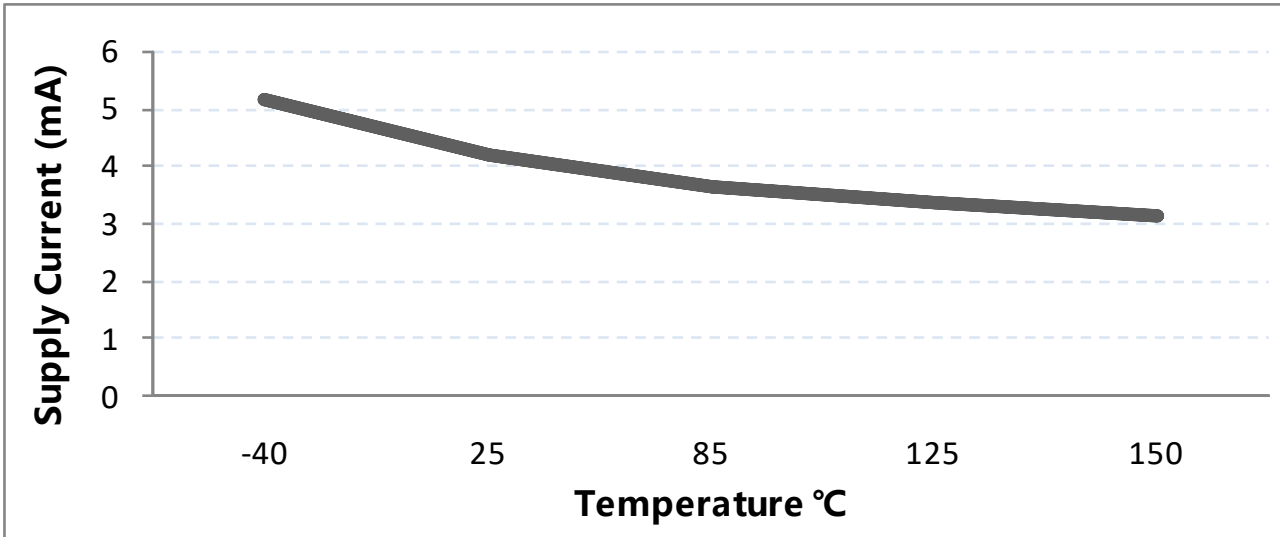

Figure.6 Supply Current vs. Temperature

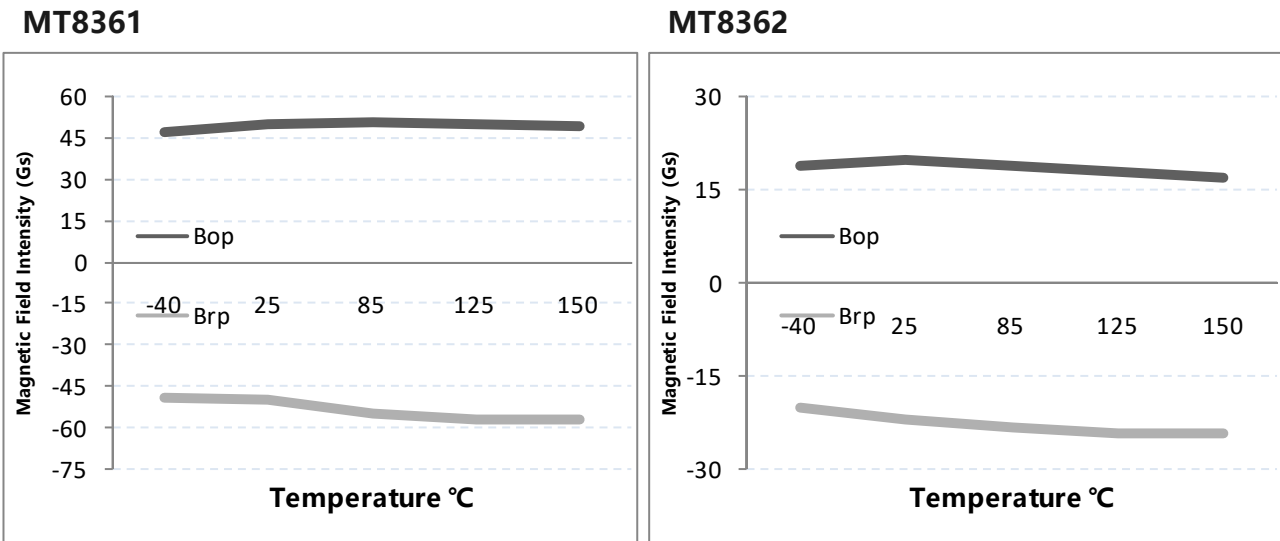

Figure.7 Magnetic Characteristics vs. Temperature (BOP & BRP)

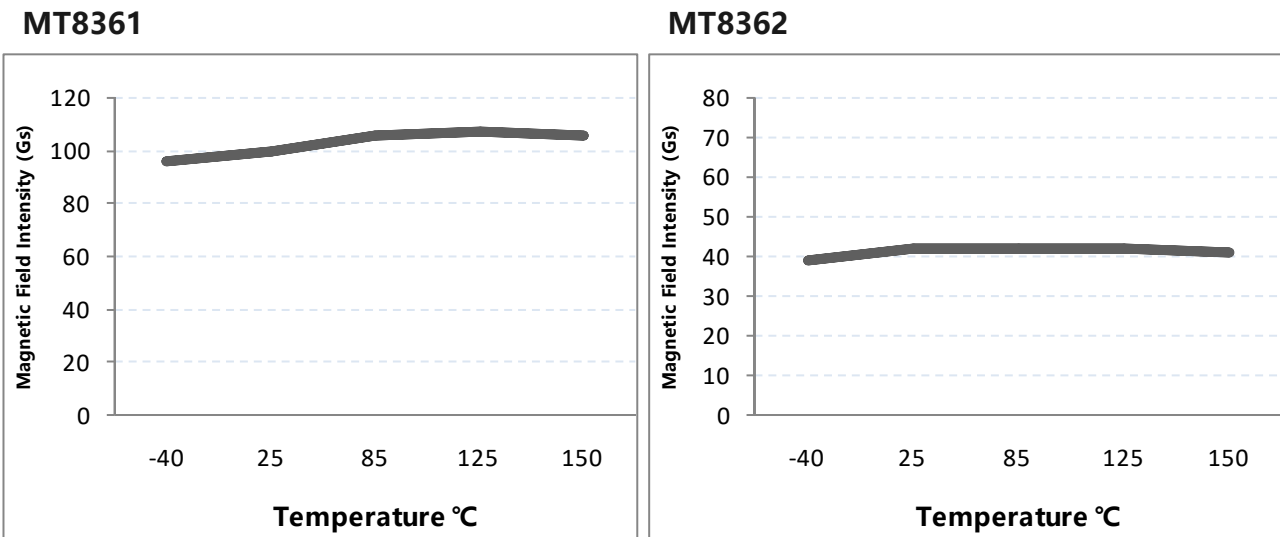

Figure.8 Magnetic Characteristics vs. Temperature (BHYST)

10.6 Typical Output Waveform

MT8361A as example

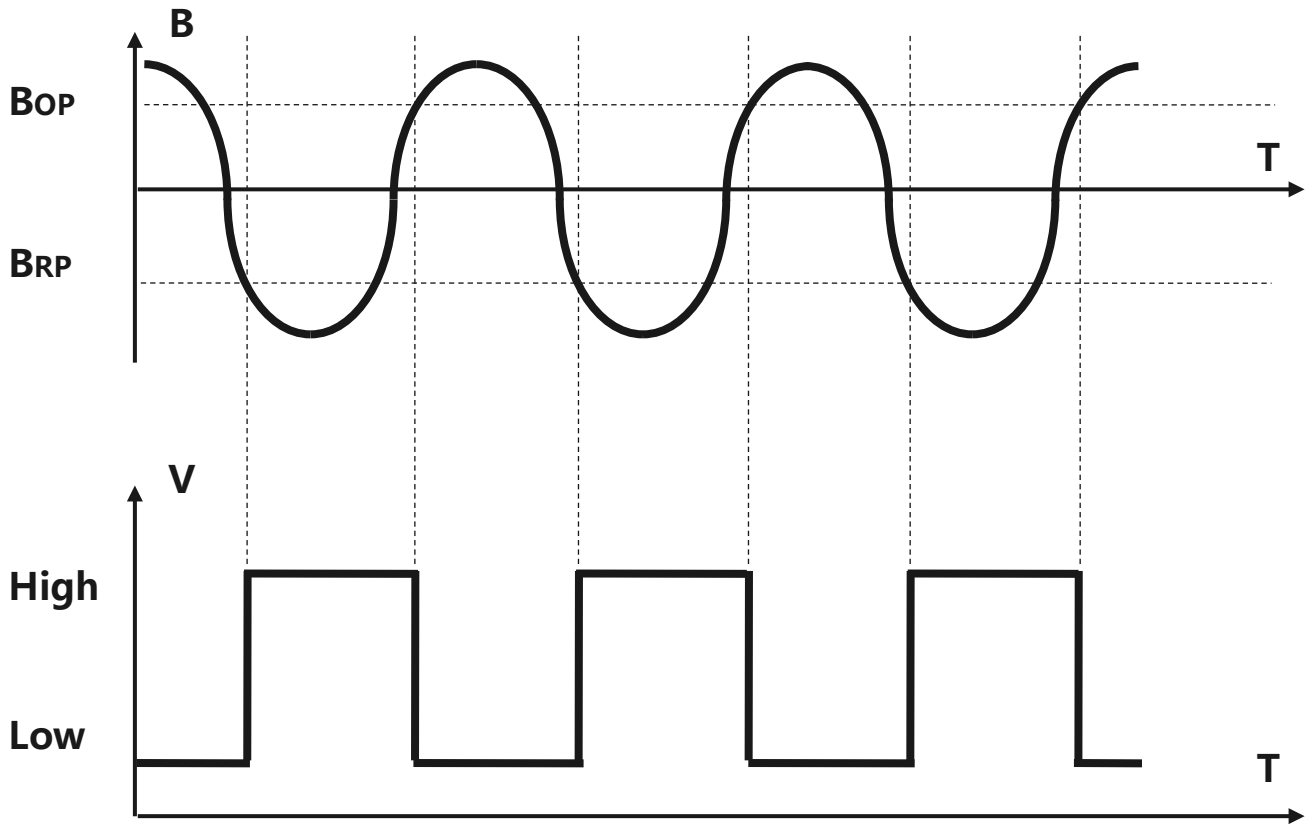

Figure.9 Digital Output vs. Magnetic Flux Density

11 Typical Application Circuit

MT8361AT as example

Note: Recommended value for R_L is 1KOhms to 10KOhms

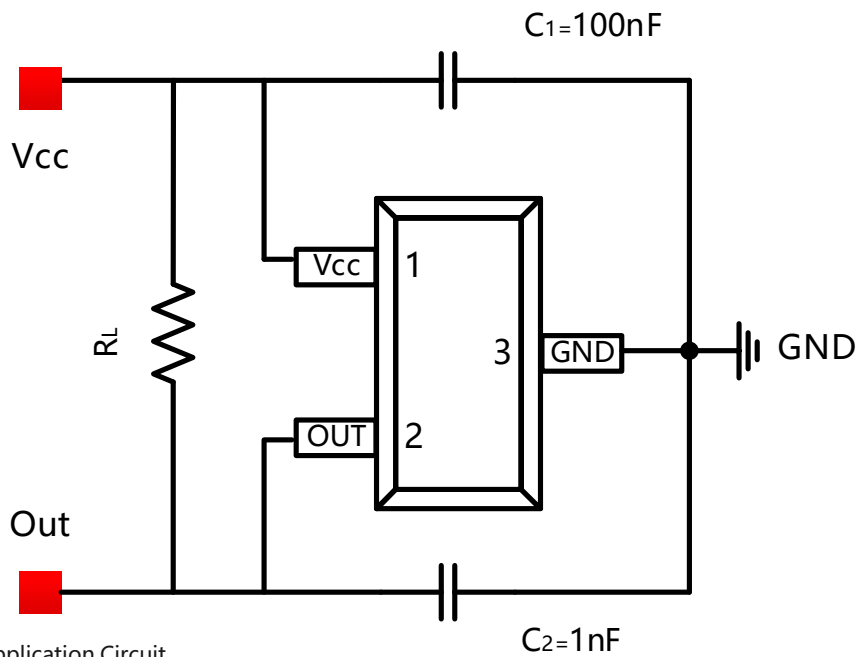

Figure.10 Typical Application Circuit

12 Package Material Information (For Reference Only – Not for Tooling Use)

12.1 SOT-23 Package Information

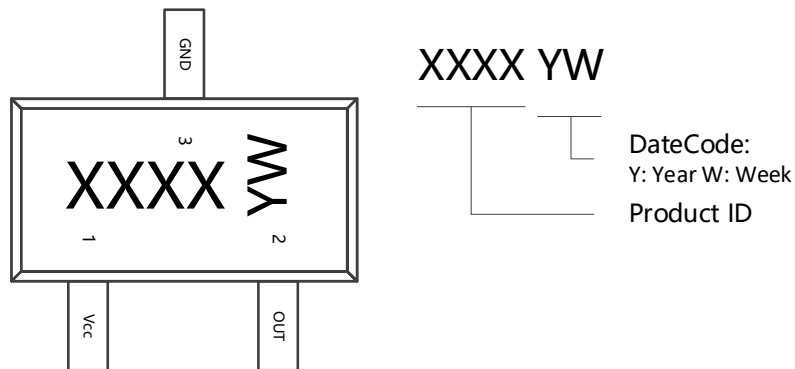

Figure.11 SOT-23 Chip Marking Spec

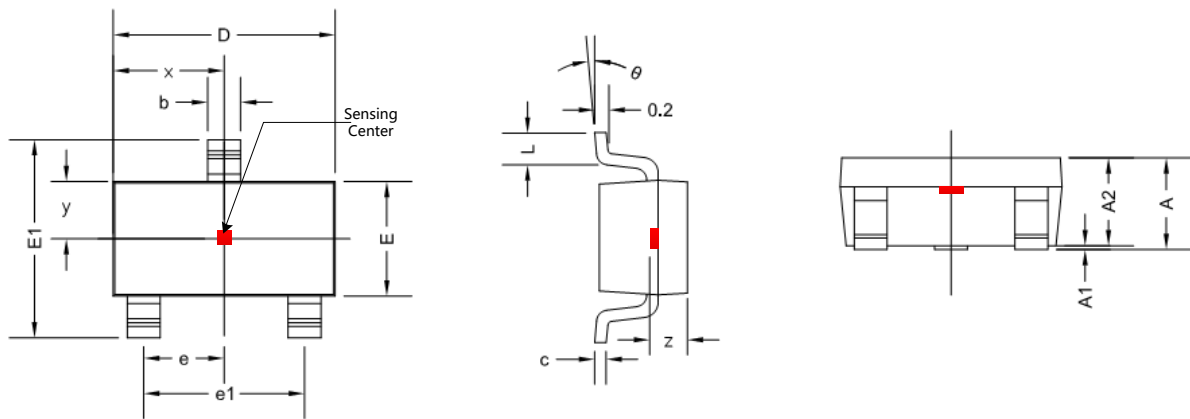

Figure.12 SOT-23 Package Drawing

Symbol	Dimensions in Millimeters		Dimensions in Inches	
	Min	Max	Min	Max
A	1.050	1.300	0.041	0.051
A1	0.000	0.150	0.000	0.006
A2	1.000	1.200	0.039	0.047
b	0.300	0.500	0.012	0.020
c	0.080	0.220	0.003	0.009
D	2.800	3.020	0.110	0.119
E	1.500	1.700	0.059	0.067
E1	2.600	3.000	0.102	0.118
e	0.950 TYP		0.037 TYP	
e1	1.800	2.000	0.071	0.079
L	0.300	0.600	0.012	0.024
θ	0 °	8 °	0 °	8 °
x	1.460 TYP		0.057 TYP	
y	0.800 TYP		0.032 TYP	
z	0.700 TYP		0.027 TYP	

12.2 SOT-23 (Thin Outline) Package Information

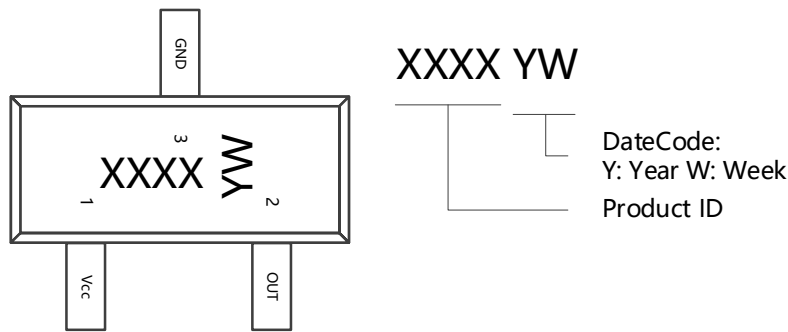

Figure.13 SOT-23 (Thin Outline) Chip Marking Spec

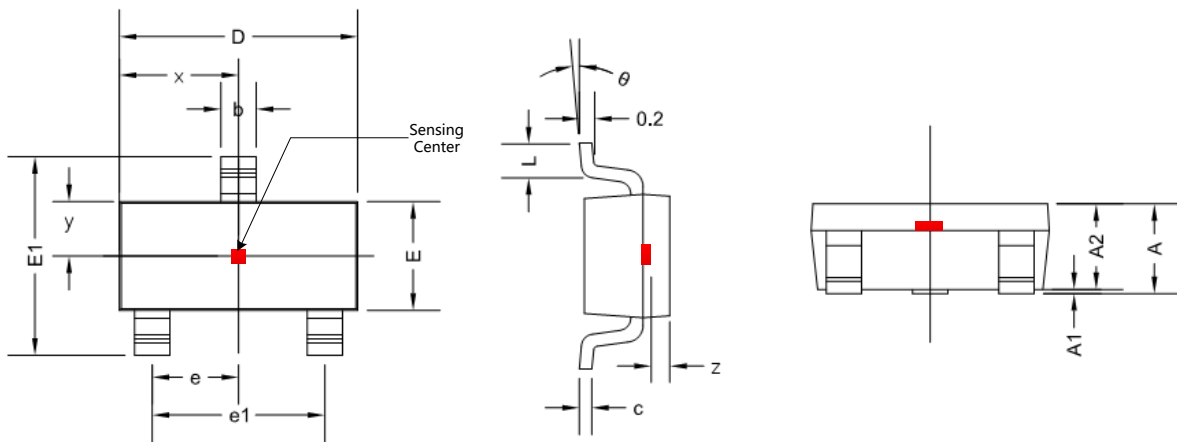

Figure.14 SOT-23 (Thin Outline) Package Drawing

Symbol	Dimensions in Millimeters		Dimensions in Inches	
	Min	Max	Min	Max
A	0.900	1.150	0.035	0.045
A1	0.000	0.100	0.000	0.004
A2	0.900	1.100	0.035	0.043
b	0.300	0.500	0.012	0.020
c	0.132	0.202	0.005	0.008
D	2.800	3.000	0.110	0.118
E	1.200	1.400	0.047	0.055
E1	2.250	2.550	0.089	0.100
e	0.950 TYP		0.037 TYP	
e1	1.800	2.000	0.071	0.079
L	0.550 REF		0.022 REF	
L1	0.300	0.500	0.012	0.020
θ	0 °	8 °	0 °	8 °
x	1.460 TYP		0.057 TYP	
y	0.650 TYP		0.026 TYP	
z	0.190 TYP		0.007 TYP	

12.3 SOT-89-3L Package Information

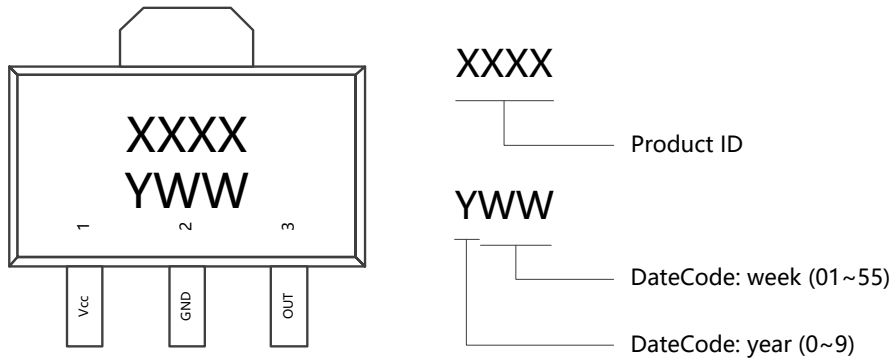

Figure.15 SOT-89-3L Chip Marking Spec



Figure.16 SOT-89-3L Package Drawing

Symbol	Dimensions in Millimeters		Dimensions in Inches	
	Min	Max	Min	Max
A	1.400	1.600	0.055	0.063
b	0.320	0.520	0.013	0.020
b1	0.380	0.580	0.015	0.023
c	0.350	0.440	0.014	0.017
D	4.400	4.600	0.173	0.181
D1	1.550 REF		0.061 REF	
D2	1.750 REF		0.069 REF	
E	3.940	4.250	0.155	0.167
E1	2.300	2.600	0.091	0.102
E2	1.900 REF		0.060 REF	
e	1.500 TYP		0.060 TYP	
e1	3.000 TYP		0.118 TYP	
L	0.900	1.200	0.035	0.047
θ	45°		45°	

12.4 Flat TO-92 Package Information

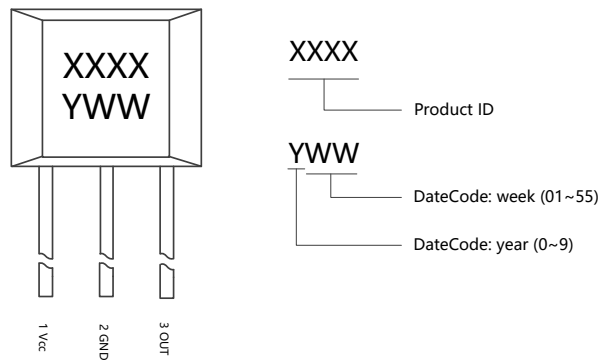

Figure.17 Flat TO-92 Chip Marking Spec

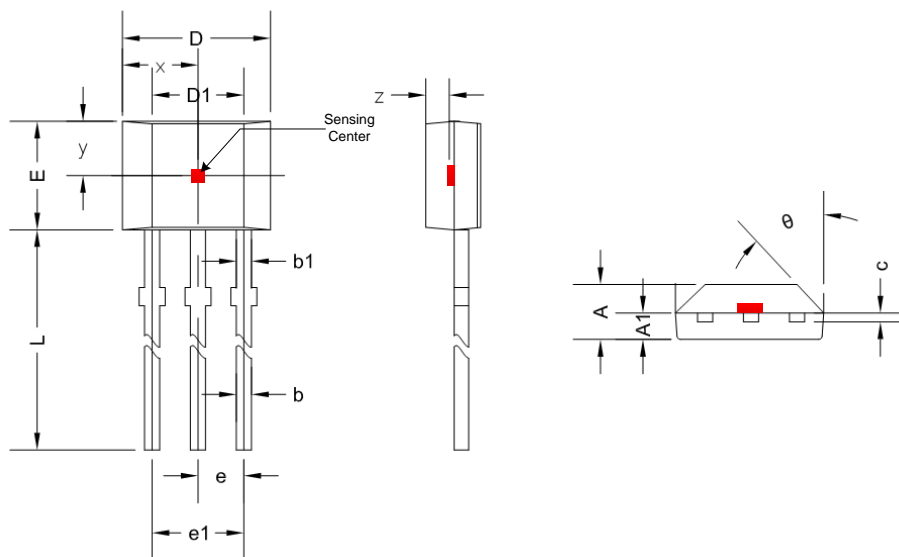

Figure.18 Flat TO-92 Package Drawing

Symbol	Dimensions in Millimeters		Dimensions in Inches	
	Min	Max	Min	Max
A	1.450	1.590	0.057	0.063
A1	0.660	0.860	0.026	0.034
b	0.330	0.480	0.013	0.019
b1	0.400	0.510	0.016	0.020
c	0.330	0.510	0.013	0.020
D	4.000	4.100	0.157	0.161
D1	2.280	2.680	0.090	0.106
E	3.050	3.250	0.120	0.128
e	1.270 TYP		0.050 TYP	
e1	2.440	2.640	0.096	0.104
L	14.350	14.750	0.565	0.581
θ	45 ° TYP		45 ° TYP	
x	2.025 TYP		0.080 TYP	
y	1.545 TYP		0.061 TYP	
z	0.500 TYP		0.020 TYP	

12.4 Flat TO-92 Package Information (Radial Lead)

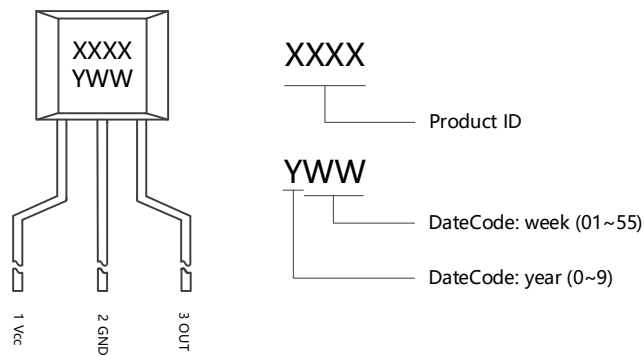

Figure.19 Flat TO-92 (Radial Lead) Chip Marking Spec

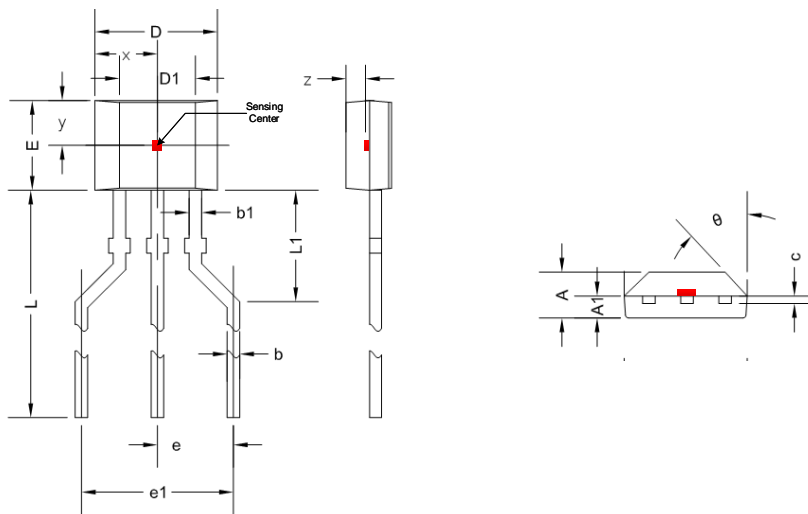

Figure.20 Flat TO-92 (Radial Lead) Package Drawing

Symbol	Dimensions in Millimeters		Dimensions in Inches	
	Min	Max	Min	Max
A	1.450	1.590	0.057	0.063
A1	0.660	0.860	0.026	0.034
b	0.330	0.480	0.013	0.019
b1	0.400	0.510	0.016	0.020
c	0.330	0.510	0.013	0.020
D	4.000	4.100	0.157	0.161
D1	2.280	2.680	0.090	0.106
E	3.050	3.250	0.120	0.128
e	2.540 TYP		0.100 TYP	
e1	5.000 TYP		0.197 TYP	
L1	2.000 TYP		0.079 TYP	
L	13.88 TYP		0.546 TYP	
θ	45 ° TYP		45 ° TYP	
x	2.025 TYP		0.080 TYP	
y	1.545 TYP		0.061 TYP	
z	0.500 TYP		0.020 TYP	

13 Copy Rights and Disclaimer

1. This document may not be reproduced or duplicated, in any form, in whole or in part without prior written consent of MagnTek . Copyrights © 2019, MagnTek Incorporated.
2. MagnTek reserves the right to make changes to the information published in this document at anytime without notice.
3. MagnTek' s products are limited for use in normal commercial applications. MagnTek' s products are not to be used in any device or system, including but not limited to medical life support equipment and system.

For the latest version of this document, please visit our website: www.magntek.com.cn