

FEATURES

1. Wide 2:1 input voltage range
2. High efficiency up to 88%
3. No-load power consumption as low as 0.11W
4. I/O isolation test voltage 1.5k VDC
5. Operating ambient temperature range: -40°C to +85°C
6. Input under-voltage protection, output short-circuit, over-current, over-voltage protection
7. Meet CISPR32/EN55032 CLASS A without extra components
8. Industry standard pin-out



3 years
Warranty

Selection Guide

Part No.	Input Voltage (VDC)		Output		Full Load Efficiency(%) Min./Typ.	Capacitive Load(μF)Max.
	Nominal (Range)	Max.	Voltage(VDC)	Current (mA) Max./Min.		
MFA1205ZP-10WR3	12 (9-18)	20	±5	±1000/0	81/83	1000
MFA1212ZP-10WR3			±12	±416/0	85/87	470
MFA1215ZP-10WR3			±15	±333/0	85/87	330
MFB1203ZP-10WR3			3.3	2400/0	84/86	1200
MFB1205ZP-10WR3			5	2000/0	84/86	1000
MFB1212ZP-10WR3			12	833/0	85/87	470
MFB1215ZP-10WR3			15	667/0	85/87	330
MFB1224ZP-10WR3			24	416/0	86/88	100
MFA2405ZP-10WR3	24 (18-36)	40	±5	±1000/0	81/83	1000
MFA2412ZP-10WR3			±12	±416/0	85/87	470
MFA2415ZP-10WR3			±15	±333/0	85/87	330
MFB2403ZP-10WR3			3.3	2400/0	83/85	1200
MFB2405ZP-10WR3			5	2000/0	85/87	1000
MFB2412ZP-10WR3			12	833/0	85/87	470
MFB2415ZP-10WR3			15	667/0	85/87	330
MFB2424ZP-10WR3			24	416/0	85/87	100
MFA4805ZP-10WR3	48 (36-75)	80	±5	±1000/0	81/83	1000
MFA4812ZP-10WR3			±12	±416/0	85/87	470
MFA4815ZP-10WR3			±15	±333/0	85/87	330
MFB4803ZP-10WR3			3.3	2400/0	84/86	1200
MFB4805ZP-10WR3			5	2000/0	85/87	1000
MFB4812ZP-10WR3			12	833/0	85/87	470
MFB4815ZP-10WR3			15	667/0	85/87	330
MFB4824ZP-10WR3			24	416/0	86/88	100

Input Specifications

Item	Operating Conditions	Min.	Typ.	Max.	Unit	
Input Current (full load / no-load)	12VDC input, nominal input voltage	3.3VDC single output	--	759/15	777/30	mA
		5VDC single output	--	958/15	980/30	
		others	--	980/9	1028/15	
	24VDC input, nominal input voltage	3.3VDC single output	--	384/10	393/25	
		5VDC single output	--	474/5	485/12	
		others	--	490/5	515/12	
	48VDC input, nominal input voltage	3.3VDC single output	--	190/8	195/20	
		5VDC single output	--	237/5	243/12	
		others	--	245/4	258/8	
Reflected Ripple Current	12VDC nominal input series, nominal input voltage	--	50	--		
	24VDC nominal input series, nominal input voltage	--	40	--		
	48VDC nominal input series, nominal input voltage	--	30	--		
Surge Voltage (1sec. max.)	12VDC nominal input series	-0.7	--	25		
	24VDC nominal input series	-0.7	--	50		
	48VDC nominal input series	-0.7	--	100		
Start-up Voltage	12VDC nominal input series	--	--	9	VDC	
	24VDC nominal input series	--	--	18		
	48VDC nominal input series	--	--	36		
Input Under-voltage Protection	12VDC nominal input series	5.5	6.5	--		
	24VDC nominal input series	12	15.5	--		
	48VDC nominal input series	25	30.5	--		
Input Filter		Pi filter				
Hot Plug		Unavailable				
Ctrl *	Module on	Ctrl pin open or pulled high (3.5-12VDC)				
	Module off	Ctrl pin pulled low to GND (0-1.2VDC)				
	Input current when off	--	6	10	mA	
Note: *The voltage of Ctrl pin is relative to input pin GND.						

Output Specifications

Item	Operating Conditions	Min.	Typ.	Max.	Unit	
Voltage Accuracy	0%-100% load	Positive output	--	±0.5	±2	%
		Negative output	--	±1	±3	
Linear Regulation	Full load, the input voltage is from low voltage to high voltage	Positive output	--	±0.2	±0.5	
		Negative output	--	±0.5	±1	
Load Regulation	5%-100% load	Positive output	--	±0.5	±1	
		Negative output	--	±0.5	±1.5	

Cross Regulation	Dual output, main circuit with 50% load, auxiliary circuit with 25%-100% load		--	--	±5	
Transient Recovery Time			--	300	500	μs
Transient Response Deviation	25% load step change, Nominal input voltage	3.3VDC/5VDC single output	--	±5	±8	%
		others	--	±3	±5	
Temperature Coefficient	Full load		--	--	±0.03	%/°C
Ripple & Noise	20MHz bandwidth, 5%-100% load	3.3VDC/5VDC single output	--	40	80	mVp-p
		others	--	40	100	
Over-voltage Protection	Input voltage range		110	--	160	%Vo
Over-current Protection	Input voltage range	3.3VDC/5VDC single output	110	160	230	%Io
		others	110	140	190	
Short-circuit Protection	Input voltage range		Continuous, self-recovery			

General Specifications

Item	Operating Conditions	Min.	Typ.	Max.	Unit
Isolation	Input-output Electric Strength Test for 1 minute with a leakage current of 1mA max.	1500	--	--	VDC
Insulation Resistance	Input-output resistance at 500VDC	1000	--	--	MΩ
Isolation Capacitance	Input-output capacitance at 100kHz/0.1V	--	2000	--	pF
Operating Temperature	see Fig. 1	-40	--	+85	°C
Storage Temperature		-55	--	+125	
Storage Humidity	Non-condensing	5	--	95	%RH
Pin Soldering Resistance Temperature	Welding spot is 1.5mm away from the casing, 10 seconds	--	--	+300	°C
Vibration		10-150Hz, 5G, 0.75mm. along X, Y and Z			
Switching Frequency *	PWM mode	--	350	--	kHz
MTBF	MIL-HDBK-217F@25°C	1000	--	--	k hours

Note: *Switching frequency is measured at full load. The module reduces the switching frequency for light load (below 50%) efficiency improvement.

Mechanical Specifications

Case Material	Aluminum alloy
Dimensions	32.00 x 20.00 x 10.80mm
Weight	12.0g(Typ.)
Cooling Method	Free air convection

EMC Specifications

EMI	CE	CISPR32/EN55032	CLASS A (without external components)/ CLASS B (see Fig.3-②)	for recommended circuit
	RE	CISPR32/EN55032	CLASS A (without external components)/ CLASS B (see Fig.3-②)	for recommended circuit
	ESD	IEC/EN61000-4-2	Contact ±4kV	perf. Criteria B

EMS	RS	IEC/EN61000-4-3	10V/m	perf. Criteria A
	EFT	IEC/EN61000-4-4	±2kV (see Fig.3-①for recommended circuit)	perf. Criteria B
	Surge	IEC/EN61000-4-5	line to line ±2kV (see Fig.3-①for recommended circuit)	perf. Criteria B
	CS	IEC/EN61000-4-6	10 Vr.m.s	perf. Criteria A
	Immunities of voltage dip, drop and short interruption	IEC/EN61000-4-29	0%, 70%	perf. Criteria B

Typical Characteristic Curves

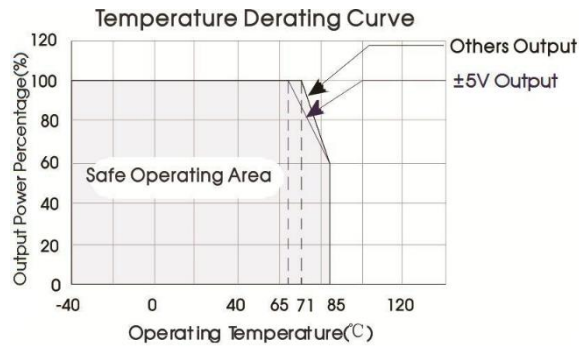
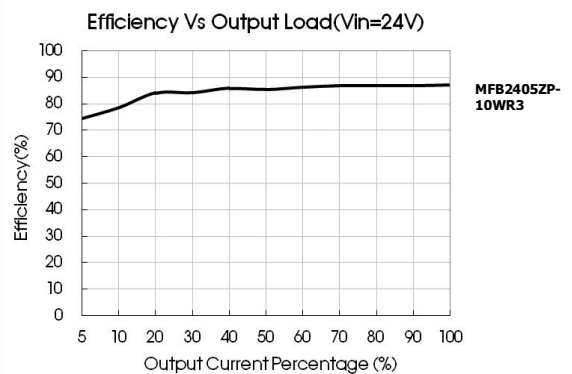
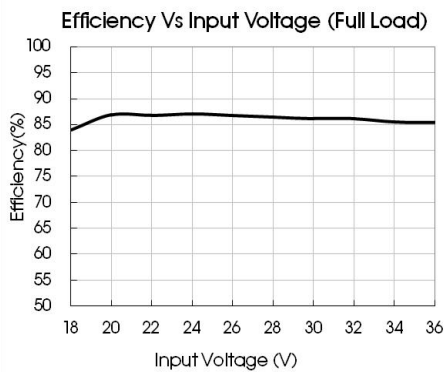
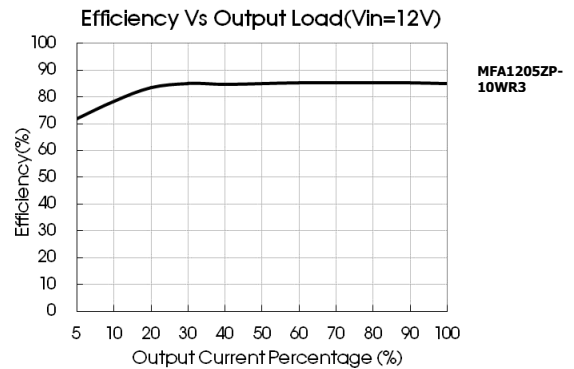
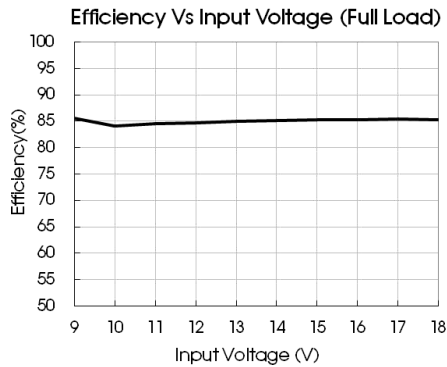
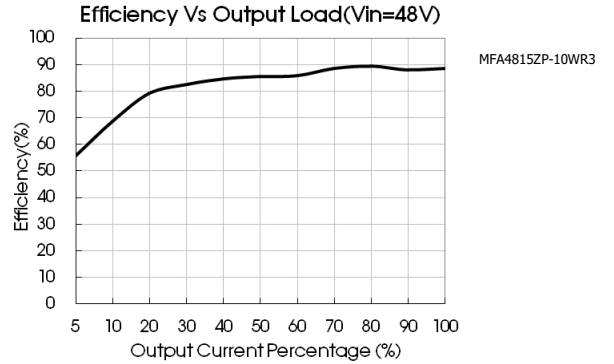
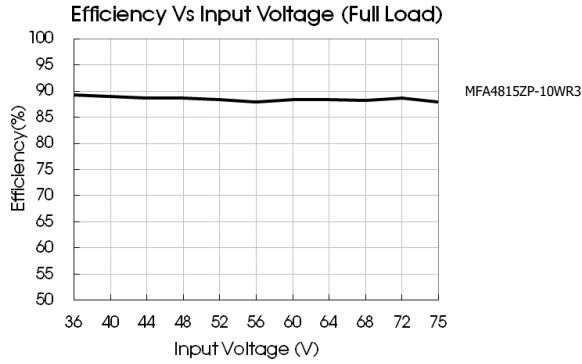

Fig. 1





Circuit Design and Application

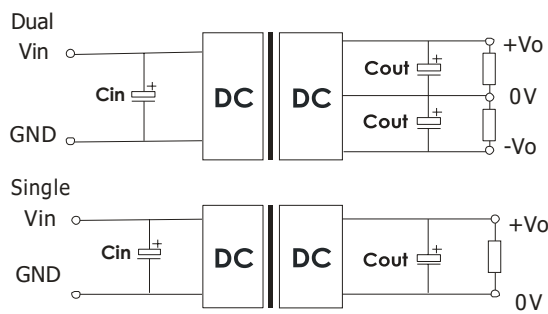
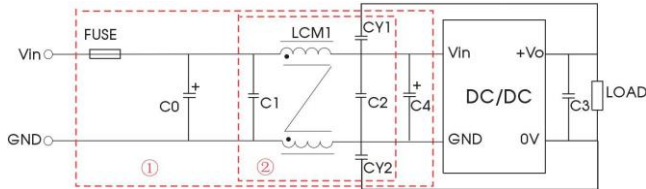

Fig. 2

Vin(VDC)	Vout(VDC)	Cin	Cout
12	3.3/5/±5	100µF/35V	10µF/16V
	12/15/±12/±15		10µF/25V
	24		10µF/50V
24	3.3/5/±5	100µF/50V	10µF/16V
	12/15/±12/±15		10µF/25V
	24		10µF/50V
48	3.3/5/±5	10µF ~47µF/100V	10µF/16V
	12/15/±12/±15		10µF/25V
	24		10µF/50V

EMC solution-recommended circuit

3.3VDC/5VDC single output:



Others:

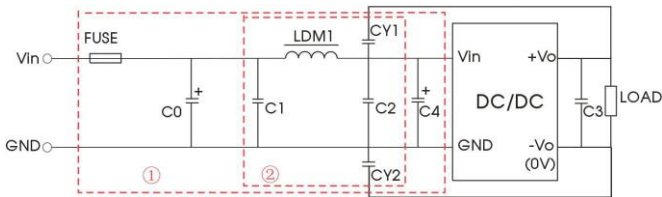

Fig. 3

Parameter description:

Model	Vin: 12VDC	Vin: 24VDC	Vin: 48VDC
FUSE	Selected based on the actual input current in application		
C0, C4	470µF/35V	330µF/50V	330µF/100V
C1, C2	10µF/50V		10µF/100V
C3	Refer to the Cout in Fig.2		
LDM1	10µH		
LCM1	1.4-1.7mH (TN150P-RH12.7*12.7*7.9)		
CY1, CY2	1nF/2kV		

Dimensions and Recommended Layout

Dimensions

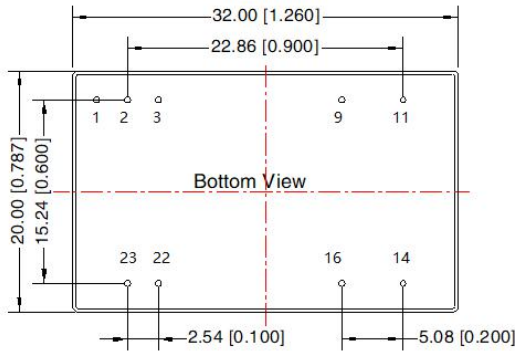
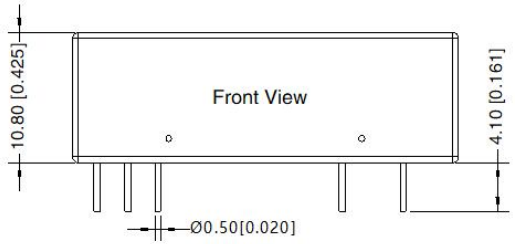

Note:
 Unit: mm[inch]
 Pin diameter tolerances: ± 0.10 [± 0.004]
 General tolerances: ± 0.50 [± 0.020]

PCB Printing Layout & Pin Definition Table

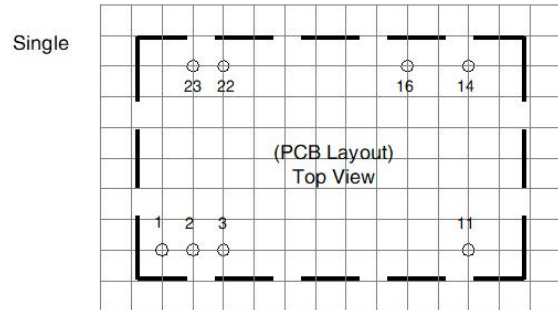
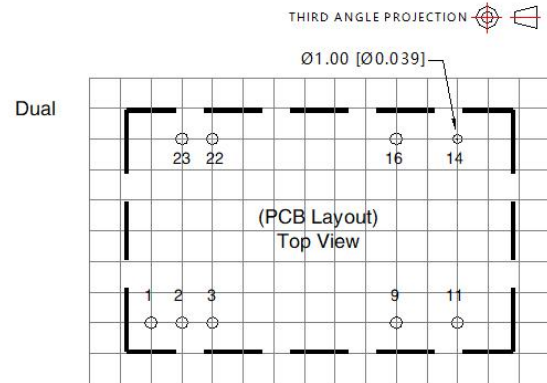

Note: Grid 2.54*2.54mm

Pin	Pin-Out	
	Single	Dual
1	Ctrl	Ctrl
2,3	GND	GND
9	No Pin	0V
11	NC	-Vo
14	+Vo	+Vo
16	0V	0V
22,23	Vin	Vin

NC: Pin to be isolated from circuit

Note:

1. If the product works under the minimum required load, it cannot guarantee that the performance of the product complies with all the performance indicators in this manual;
2. The maximum capacitive load is tested under the input voltage range and full load condition;
3. Unless otherwise stated, all indexes in this manual are measured at $T_a=25^\circ\text{C}$, humidity $<75\%RH$, nominal input voltage and rated output load;
4. All index testing methods in this manual are based on the enterprise standards of the company;
5. Our company can provide product customization, specific needs can directly contact our technical staff;