



SPECIFICATION

OF PRODUCTS

CUSTOMER : _____

PRODUCT NAME: DIELECTRIC ANTENNA ELEMENT

PART NUMBER : G09B-Ant

Approved by	Checked by	Drawn by



Approval Sheet	
Customer	
Supplier P/N	G09B-Ant
Customer P/N	

Customer's Approval Certificate	
Checked & Approved by	
Date	

Please return this copy as a certification of your approval.

1 SCOPE

This specification shall cover the characteristics of the dielectric antenna element with the type G09B-Ant.

2 PART NO.

PART NUMBER	CUSTOMER PART NO	SPECIFICATION NO
G09B-Ant		

3 OUTLINE DRAWING AND DIMENSIONS

3.1 Appearance: No visible damage and dirt.

3.2 The products conform to the RoHS directive and national environment protection law.

3.3 Dimensions

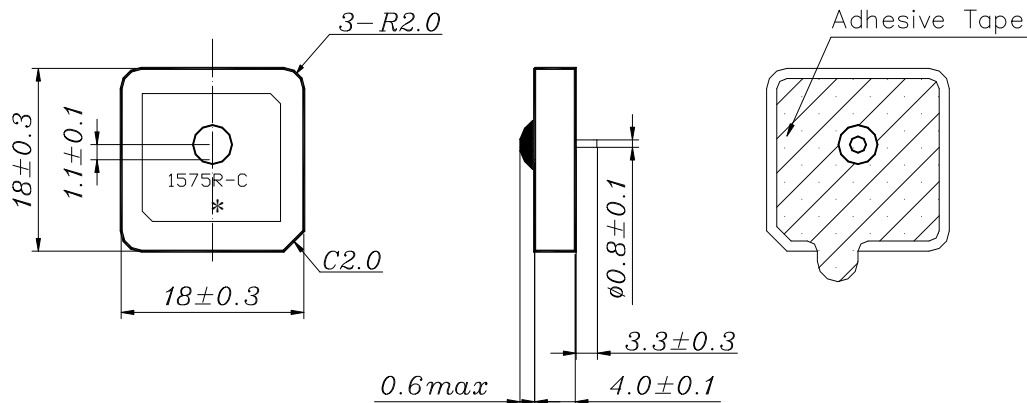

*:EIAJ MONTHLY CODE

4 ELECTRICAL SPECIFICATIONS

4.1 Performance Characteristics

Items	Content
Nominal frequency MHz	1575.42±1.023
Center frequency MHz (without tape on 70×70mm ground plane)	1575.0±3.0
-10dB Bandwidth MHz min	11
VSWR at CF max	1.5
Polarization Model	RHCP
Impedance Ω	50
Gain (Zenith 90°) dBi max	3
Frequency Temperature Coefficient	20ppm/deg.°C max
Working Temperature	-40°C to +105°C

4.2 Impedance Characteristic

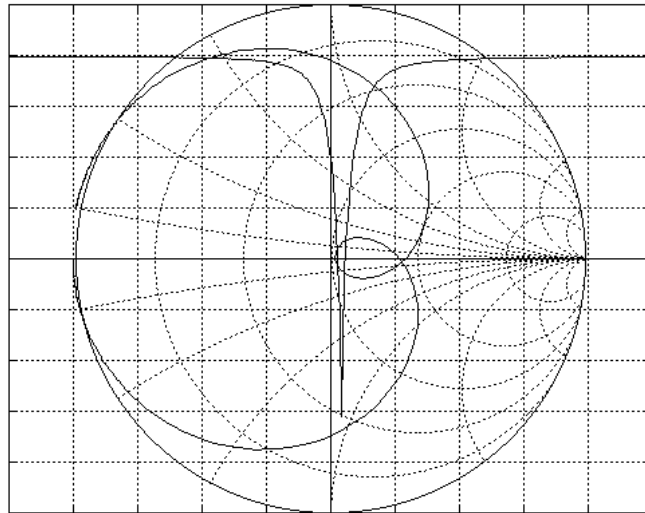

5 TEST

5.1 Test Conditions

Parts shall be measured under a condition (Temp.: $20^{\circ}\text{C}\pm 15^{\circ}\text{C}$, Humidity : $65\%\pm 20\%$ R.H.).

5.2 Test Jig

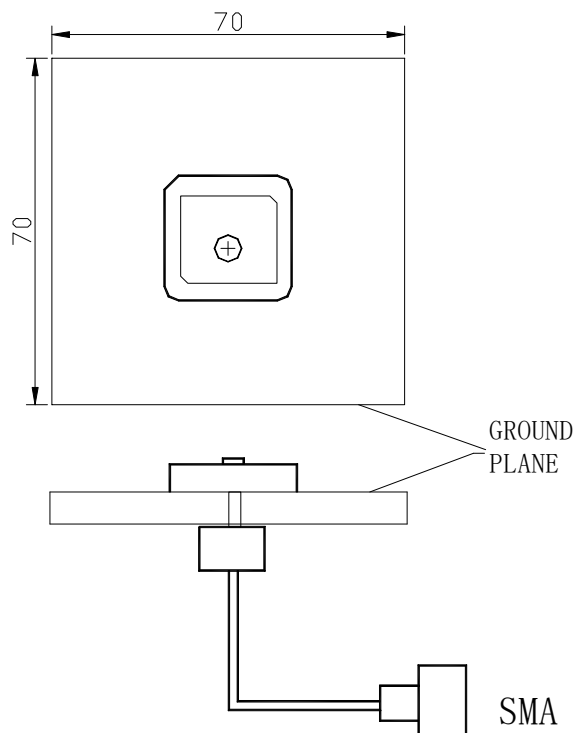

6 ENVIRONMENTAL TEST

No.	Item	Test Condition	Remark
6.1	Humidity Test	The device is subjected to 90%~95% relative humidity $60^{\circ}\text{C}\pm 3^{\circ}\text{C}$ for 96h~98h, then dry out	It shall fulfill the

		at $25\text{ }^{\circ}\text{C} \pm 5\text{ }^{\circ}\text{C}$ and less than 65% relative humidity for 2h~4h. After dry out the device shall satisfy the specification in table 1.	specifications in Table 1.
6.2	High Temperature Exposure	The device shall satisfy the specification in table 1 after leaving at $105\text{ }^{\circ}\text{C}$ for 96h~98h, provided it would be measured after 2h~4h leaving in $25\text{ }^{\circ}\text{C} \pm 5\text{ }^{\circ}\text{C}$ and less than 65% relative humidity.	It shall fulfill the specifications in Table 1.
6.3	Low Temperature	The device shall satisfy the specification in table 1 after leaving at $-40\text{ }^{\circ}\text{C}$ for 96h~98h, provided it would be measured after 2h~4h leaving in $25\text{ }^{\circ}\text{C} \pm 5\text{ }^{\circ}\text{C}$ and less than 65% relative humidity.	It shall fulfill the specifications in Table 1.
6.4	Temperature Cycle	Subject the device to $-40\text{ }^{\circ}\text{C}$ for 30 min. followed by a high temperature of $105\text{ }^{\circ}\text{C}$ for 30 min cycling shall be repeated 5 times. At the room temperature for 1h prior to the measurement.	It shall fulfill the specifications in Table 1.
6.5	Vibration	Subject the device to vibration for 2h each in x、y and z axis with the amplitude of 1.5mm, the frequency shall be varied uniformly between the limits of 10Hz~55Hz.	It shall fulfill the specifications in Table 1.
6.6	Soldering Test	Lead terminals are heated up to $350\text{ }^{\circ}\text{C} \pm 10\text{ }^{\circ}\text{C}$ for $5\text{s} \pm 0.5\text{ s}$ with brand iron and then element shall be measured after being placed in natural conditions for 1 h. No visible damage and it shall fulfill the specifications in Table 1	It shall fulfill the specifications in Table 1.
6.7	Solder ability	Lead terminals are immersed in soldering bath of $260\text{ }^{\circ}\text{C} \sim 290\text{ }^{\circ}\text{C}$ for $3\text{s} \pm 0.5\text{s}$. More than 95% of the terminal surface of the device shall be covered with fresh solder.	The terminals shall be at least 95% covered by solder.
6.8	Terminal Pressure Strength	Force of 2kg is applied to each lead in axial direction for $10\text{s} \pm 1\text{ s}$ (see drawing). No visible damage and it shall fulfill the specifications in Fig 1	Mechanical damage such as breaks shall not occur.

FIG 1

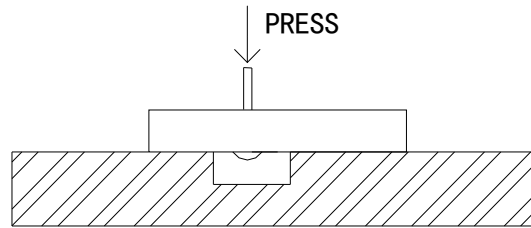

TABLE 1

Item	Specification After Test (MHz)
Center Frequency change	± 2.0
-10dB Bandwidth Change	± 2.0

7. PACKAGE

To protect the products in storage and transportation, it is necessary to pack them (outer and inner package). On paper pack, the following requirements are requested.

7.1 Dimensions and Mark

At the end of package, the warning (moisture proof, upward put) should be stick to it. Dimensions and Mark (see below)

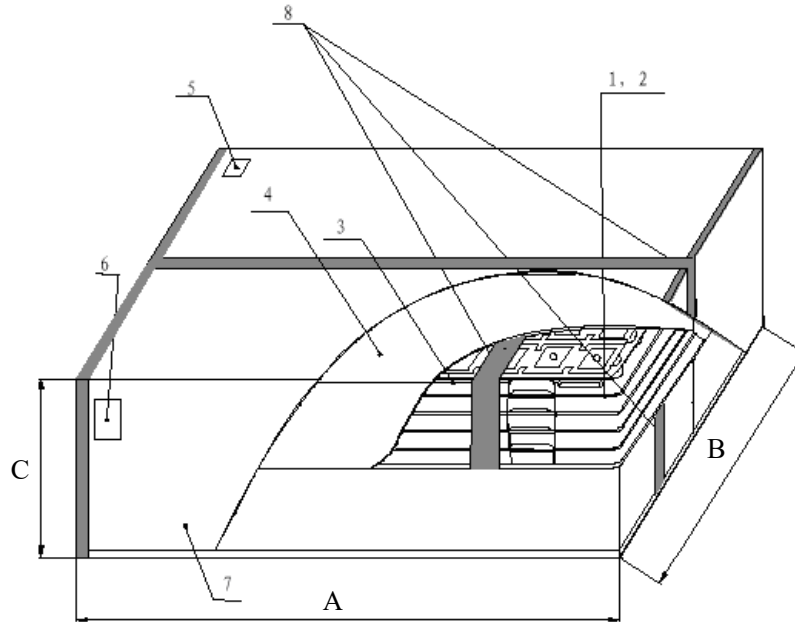

A:355 B:315 C:190

NO.	Name	Quantity
1	Cushion	20
2	Package	24
3	Vacuum Bag	4
4	Inner Box	4
5	Label	5
6	Certificate of approval	1
7	Package base	1
8	Adhesive tape	3.0m

7.2 Section of package

Package is made of corrugated paper with thickness of 0.8cm. Package has 4 inner boxes, each box has 1 vacuum bag.

7.3 Quantity of package

Per package base 50 elements

Per vacuum bag 6 package bases
 Per inner box 1 vacuum bag
 Per package 4 inner boxes
 (1000 pieces of elements)

7.4 Inner box Dimensions

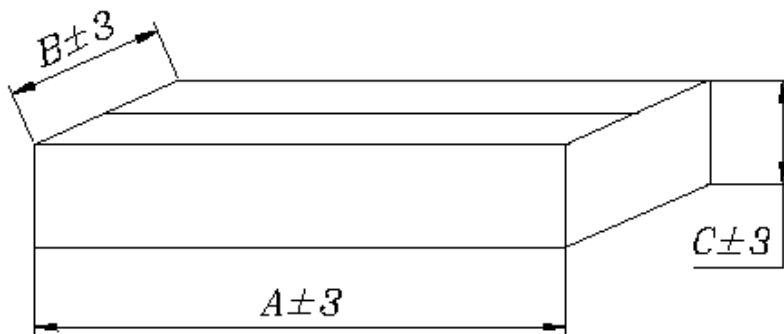

A:300 B:170 C: 85

8. EIAJ Monthly Code

2007 / 2009/2011/2013/2015		2006 / 2008 / 2010/2012/2014	
MONTH	CODE	MONTH	CODE
JAN	A	JAN	N
FEB	B	FEB	P
MAR	C	MAR	Q
APR	D	APR	R
MAY	E	MAY	S
JUN	F	JUN	T
JUL	G	JUL	U



AUG	H	AUG	V
SEP	J	SEP	W
OCT	K	OCT	X
NOV	L	NOV	Y
DEC	M	DEC	Z

9. OTHER

9.1 Caution of use

9.1.1 Please don't apply excess mechanical stress to the component and terminals at soldering.

9.1.2 The component may be damaged when an excess stress will be applied.

9.1.3 This specification mentions the quality of the component as a single unit. Please insure the component is thoroughly evaluated in your application circuit.

9.2 Notice

9.2.1 Please return one of these specifications after your signature of acceptance.

9.2.2 When something gets doubtful with this specification, we shall jointly work to get an agreement