



Preliminary Specification
Final Specification

Module	21.5" Color TFT-LCD
Model Name	G215HVN01.0

Customer	Date
_____	_____
Checked & Approved by	
_____	_____

Approved by	Date
<u>Crystal Hsieh</u>	<u>2014/09/05</u>
Prepared by	
<u>Jimmy Tsai</u>	<u>2014/09/05</u>

Note: This Specification is subject to change without notice.

General Display Business Division / AU Optronics corporation



Contents

1. Operating Precautions5

2. General Description6

 2.1 Display Characteristics 6

 2.2 Optical Characteristics..... 7

3. Functional Block Diagram11

4. Absolute Maximum Ratings.....12

 4.1 TFT LCD Module 12

 4.2 Backlight Unit..... 12

5. Electrical Characteristics.....14

 5.1 TFT LCD Module 14

 5.2 Backlight Unit..... 16

6. Signal Characteristic.....17

 6.1 Pixel Format Image 17

 6.2 Signal Description..... 18

 6.3 The Input Data Format 19

 6.4 Interface Timing 20

 6.5 Power ON/OFF Sequence..... 21

7. Connector & Pin Assignment22

 7.1 TFT LCD Module: LVDS Connector 22

 7.2 Backlight Unit: LED Connector 23

8. Reliability Test24

9. Mechanical Characteristics25

10. Label and Packaging.....26

 10.1 Shipping Label (on the rear side of TFT-LCD display)..... 26

 10.2 Carton Package..... 26

11. Safety27

 11.1 Sharp Edge Requirements..... 27

 11.2 Materials 27

 11.3 Capacitors..... 27

 11.4 National Test Lab Requirement..... 27

Record of Revision

Version and Date	Page	Old description	New Description	Remark
0.1 2011/11/03	All	First Edition	All	
0.2 2012/02/03	26			
1.0 2012/11/23	5, 15	[Watt], VDD: 4.4 + LED: 22 = 26.4 (Typ.) (with LED driver board, all white pattern).	Power Consumption [Watt]: 23 W (Typ. Cell 3.5 + LED 19.2) (with LED driver board, all white pattern).	
	6, 11	Operating Temp: 0 to +50C	Operating Temp: 0 to +60C	
	15			
1.1 2013/12/03	15			
	20			
	22	Back light dimming, 3.3V	Back light dimming	
1.2 2014/06/24	6	Contrast ratio: 5,000 (typ.)	Contrast ratio: 3,000 (typ.)	
	17			
1.3 2014/07/31	6			
	6			
	24	Thickness = 16.85 mm (typ.)	Update drawing (t=12.7 mm)	
1.4 2014/08/08	5	23 W (Typ. Cell 3.5 + LED 19.2) (with LED driver board, all white pattern).	19.82 W (Typ. Cell 3.5 + LED 16.32) (with LED driver board, all white pattern).	
	15			
	15	LED q'ty= 60 pcs	LED q'ty= 65 pcs	
	25	10.2 Carton Package Max capacity: 21.5' TFT-LCD module per carton (3,855 * 1 layers) Max weight: 20.3 kg per carton. Outside dimension of carton: 564 mm x 273mmx 373 mm.	Max capacity : 9 TFT-LCD module per carton. Max weight: 20.7 kg per carton. Outside dimension of carton: 570mm*275mm*385mm.	
1.5 2014/09/05	6, 7	Contrast ratio: 3,000 (typ.)	Contrast ratio: 5,000 (typ.)	
	20			

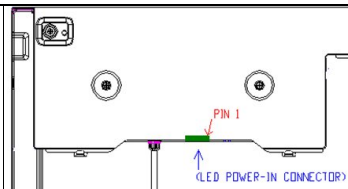
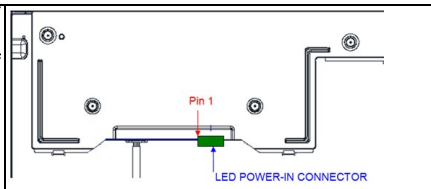
	23	 <p>(components face up)</p>	 <p>(components face down)</p>	

1. Operating Precautions

- 1) Since front polarizer is easily damaged, pay attention not to scratch it.
- 2) Be sure to turn off power supply when inserting or disconnecting from input connector.
- 3) Wipe off water drop immediately. Long contact with water may cause discoloration or spots.
- 4) When the panel surface is soiled, wipe it with absorbent cotton or other soft cloth.
- 5) Since the panel is made of glass, it may break or crack if dropped or bumped on hard surface.
- 6) Since CMOS LSI is used in this module, take care of static electricity and insure human earth when handling.
- 7) Do not open or modify the Module Assembly.
- 8) In case if a Module has to be put back into the packing container slot after once it was taken out from the container, take it easily, or the TFT Module may be damaged.
- 9) At the insertion or removal of the Signal Interface Connector, be sure not to rotate nor tilt the Interface Connector of the TFT Module.
- 10) After installation of the TFT Module into an enclosure, do not twist nor bend the TFT Module even momentary. At designing the enclosure, it should be taken into consideration that no bending/twisting forces are applied to the TFT Module from outside. Otherwise the TFT Module may be damaged.
- 11) Small amount of materials having no flammability grade is used in the LCD module. The LCD module should be supplied by power complied with requirements of Limited Power Source (IEC60950 or UL1950), or be applied exemption.
- 12) Severe temperature condition may result in different luminance, response time and LED life time.
- 13) The data on this specification sheet is applicable when LCD module is placed in landscape position.
- 14) Continuous displaying fixed pattern may induce image sticking. It is recommended to use screen saver or shuffle content periodically if fixed pattern is displayed on the screen.

2. General Description

This specification applies to the 21.5 inch-wide Color TFT-LCD Module G215HVN01.0. The display supports the Full HD - 1920(H) x 1080(V) screen format and 16.7M colors (RGB 8-bits data). All input signals are dual channel LVDS interface.

LED driver board is included. G215HVN01.0 is designed for industrial display applications.

2.1 Display Characteristics

The following items are characteristics summary on the table under 25 °C condition:

ITEMS	Unit	SPECIFICATIONS
Screen Diagonal	[mm]	546.86(21.53")
Active Area	[mm]	476.64 (H) x 268.11 (V)
Pixels H x V		1920(x3) x 1080
Pixel Pitch	[um]	248.25 (per one triad) ×248.25
Pixel Arrangement		R.G.B. Vertical Stripe
Display Mode		VA Mode, Normally Black
White Luminance (Center)	[cd/m ²]	300 (Typ.)
Contrast Ratio		5000 (Typ.)
Optical Response Time	[msec]	25 ms (Typ., on/off)
Nominal Input Voltage	[Volt]	+5.0 V
Backlight Input Voltage	[Volt]	+12.0 V
Power Consumption	[Watt]	19.82 W (Typ. Cell 3.5 + LED 16.32) (with LED driver board, all white pattern)
Weight	[Grams]	2300 (max.)
Physical Size	[mm]	495.6(W) × 292.2(H) × 12.7(D)
Electrical Interface		Dual channel LVDS
Support Color		16.7M colors (RGB 8 bits)
Surface Treatment		Anti-Glare, 3H
Temperature Range		
Operating	[°C]	0 to +60
Storage (Non-Operating)	[°C]	-20 to +60
RoHS Compliance		RoHS Compliance
TCO Compliance		TCO 5.1 Compliance

2.2 Optical Characteristics

The optical characteristics are measured under stable conditions at 25 °C :

Item	Unit	Conditions	Min.	Typ.	Max.	Note
Viewing Angle	[degree]	Horizontal (Right) CR = 10 (Left)	75 75	89 89	- -	1, 2
	[degree]	Vertical (Upper) CR = 10 (Lower)	75 75	89 89	- -	
Contrast ratio		Normal Direction	3000	5000	-	3
Response Time	[msec]	Raising Time (T _{IR})	-	20	25	4
		Falling Time (T _{IF})	-	5	10	
		Raising + Falling	-	25	35	
Color / Chromaticity Coordinates (CIE)		Red x	0.589	0.639	0.689	5
		Red y	0.283	0.333	0.383	
		Green x	0.253	0.303	0.353	
		Green y	0.573	0.623	0.673	
		Blue x	0.105	0.155	0.205	
		Blue y	0.000	0.048	0.098	
Color Coordinates (CIE) White		White x	0.263	0.313	0.363	
		White y	0.279	0.329	0.379	
Central Luminance	[cd/m ²]		240	300	-	6
Luminance Uniformity	[%]		75	80	-	7
Crosstalk (in 60Hz)	[%]				1.5	8
Flicker	dB				-20	9

Note 1: Measurement method

Before measuring, the LCD module should be turned on 30 minutes at room temperature. In order to stabilize the luminance, the measurement should be executed after lighting Backlight for 30 minutes in a stable, windless and dark room.

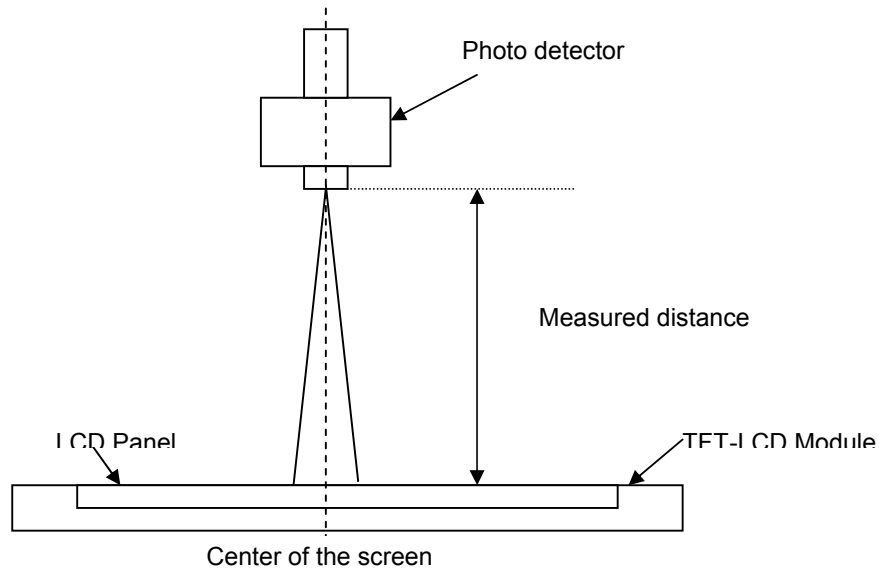

Note 2: Definition of viewing angle measured by ELDIM (EZContrast 88)

Viewing angle is the measurement of contrast ratio 10, at the screen center, over a 180° horizontal and 180° vertical range (off-normal viewing angles). The 180° viewing angle range is broken down as follows; 90° (θ) horizontal left and right and 90° (ϕ) vertical, high (up) and low (down). The measurement direction is typically perpendicular to the display surface with the screen rotated about its center to develop the desired measurement viewing angle.

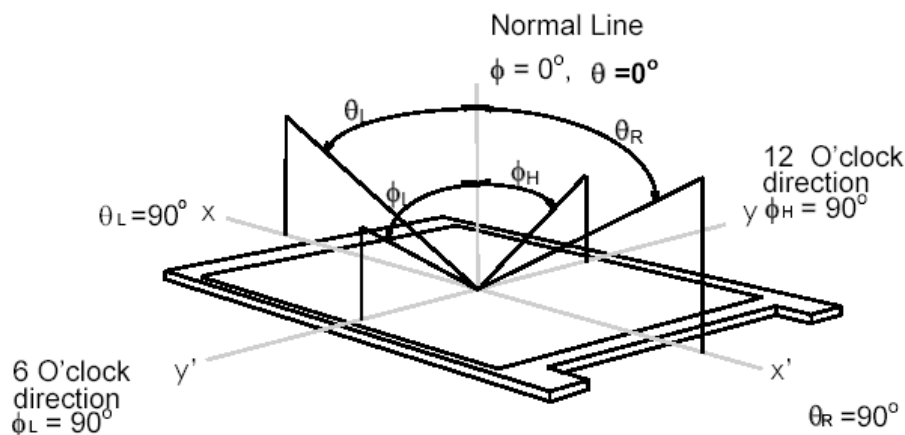

Note 3: Contrast ratio is measured by TOPCON SR-3

Note 4: Definition of Response time measured by Westar TRD-100A

The output signals of photo detector are measured when the input signals are changed from “Full Black” to “Full White” (rising time, T_{rR}), and from “Full White” to “Full Black” (falling time, T_{rF}), respectively. The response time is interval between the 10% and 90% (1 frame at 60 Hz) of amplitudes.

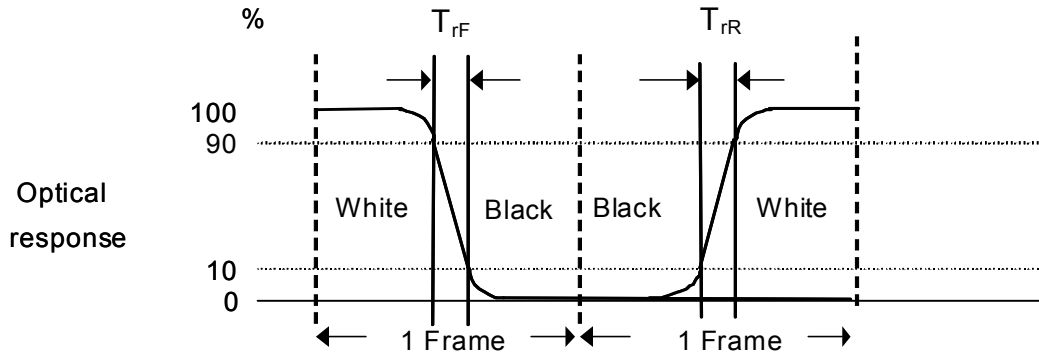

Note 5: Color chromaticity and coordinates (CIE) is measured by TOPCON SR-3

Note 6: Central luminance is measured by TOPCON SR-3

Note 7: Luminance uniformity of these 9 points is defined as below and measured by TOPCON SR-3

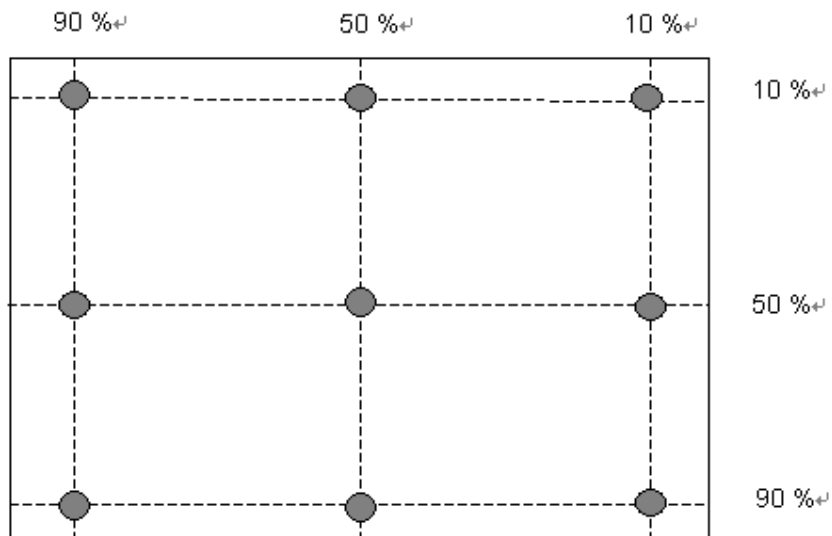

$$\text{Uniformity} = \frac{\text{Minimum Luminance in 9 points (1-9)}}{\text{Maximum Luminance in 9 Points (1-9)}}$$

Note 8: Crosstalk is defined as below and measured by TOPCON SR-3

$$CT = |Y_B - Y_A| / Y_A \times 100 (\%)$$

Where

Y_A = Luminance of measured location without gray level 0 pattern (cd/m²)

Y_B = Luminance of measured location with gray level 0 pattern (cd/m²)

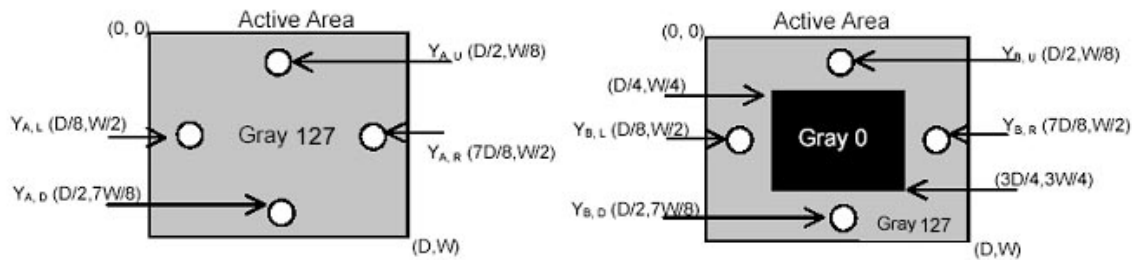

Note 9: Test Pattern: Subchecker Pattern measured by TOPCON SR-3

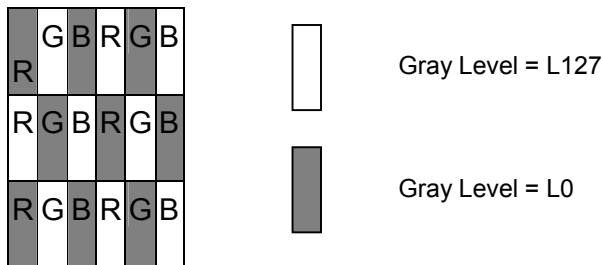

Method: Record dB value with TRD-100

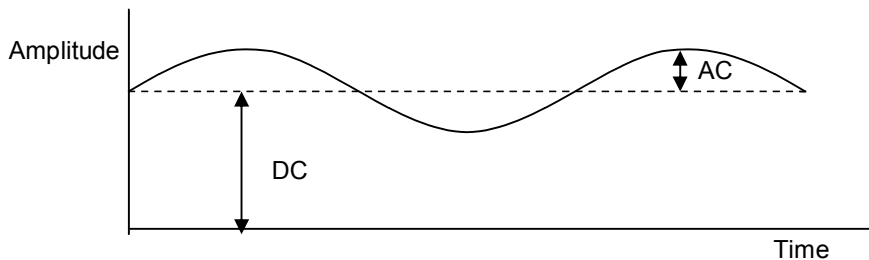

$$\text{Flicker (dB)} = 20 \log \frac{\text{AC Level (at 30 Hz)}}{\text{DC Level}}$$

3. Functional Block Diagram

The following diagram shows the functional block of this model.

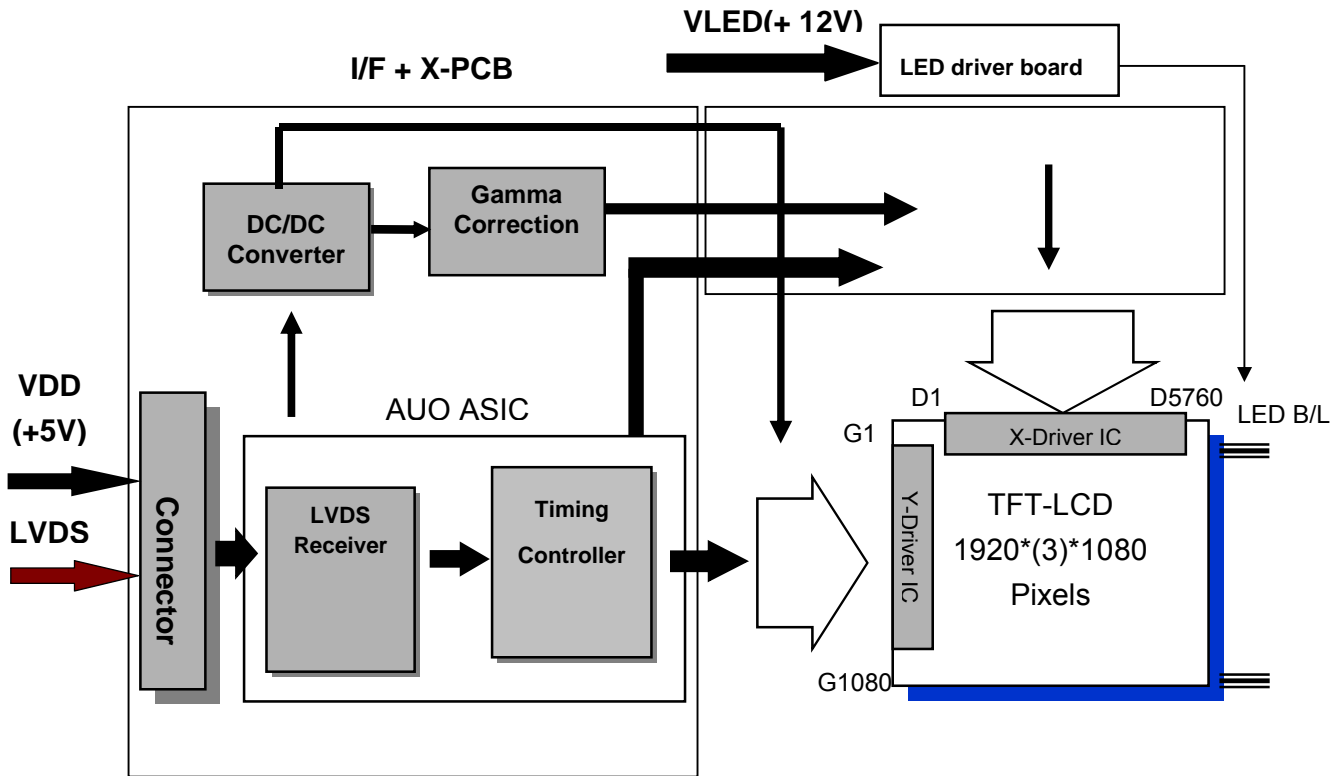

LVDS Connector: JAE (FI-XB30SRL-HF11) or equivalent.
 LED Connector: Sin Sheng (MS24049HJ) or equivalent.

4. Absolute Maximum Ratings

4.1 TFT LCD Module

Item	Symbol	Min	Max	Unit	Conditions
Logic/LCD Drive Voltage	VDD	0	5.5	[Volt]	Note 1,2

4.2 Backlight Unit

Item	Symbol	Min	Max	Unit	Conditions
LED Input Voltage	VLED	10.8	13.2	[Volt]	Note 1,2

4.3 Absolute Ratings of Environment

Item	Symbol	Min.	Max.	Unit	Conditions
Operating Temperature	TOP	0	+60	[°C]	Note 3 & 4
Operation Humidity	HOP	5	90	[%RH]	
Storage Temperature	TST	-20	+60	[°C]	
Storage Humidity	HST	5	90	[%RH]	

Note 1: With in Ta (25)

Note 2: Permanent damage to the device may occur if exceeding maximum values

Note 3: For quality performance, please refer to AUO IIS (Incoming Inspection Standard).

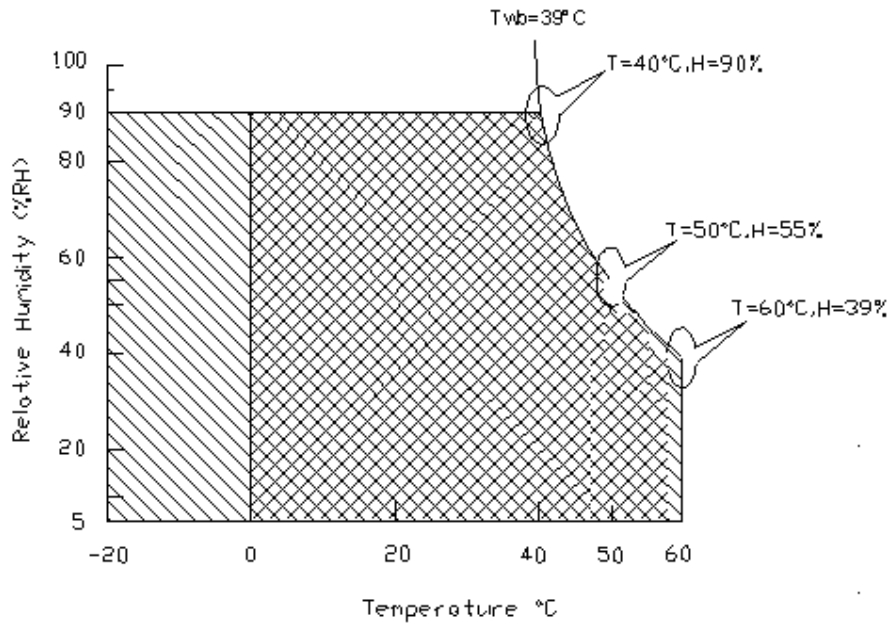

Operating Range  Storage Range  + 

Note 4: Operation Temperature + 60°C is defined as panel surface temperature.

5. Electrical Characteristics

5.1 TFT LCD Module

5.1.1 Power Specification

Symbol	Parameter	Min	Typ	Max	Unit	Conditions
VDD	Logic/LCD Drive Voltage	4.5	5.0	5.5	[Volt]	+/-10%
IDD	Input Current	-	0.7	0.8	[A]	VDD= 5.0V, All white pattern, At 60Hz
		-	0.81	0.89	[A]	VDD= 5.0V, All white pattern At 75Hz,
PDD	VDD Power	-	3.5	4.4	[Watt]	VDD= 5.0V, All white pattern, At 60Hz
		-	4.05	4.9	[Watt]	VDD= 5.0V, All white pattern At 75Hz,
IRush	Inrush Current	-	-	3	[A]	Note 1
VDDrp	Allowable Logic/LCD Drive Ripple Voltage	-	-	500	[mV] p-p	VDD= 5.0V, All white Pattern At 75Hz

Note 1: Measurement conditions:

The duration of rising time of power input is 470us.

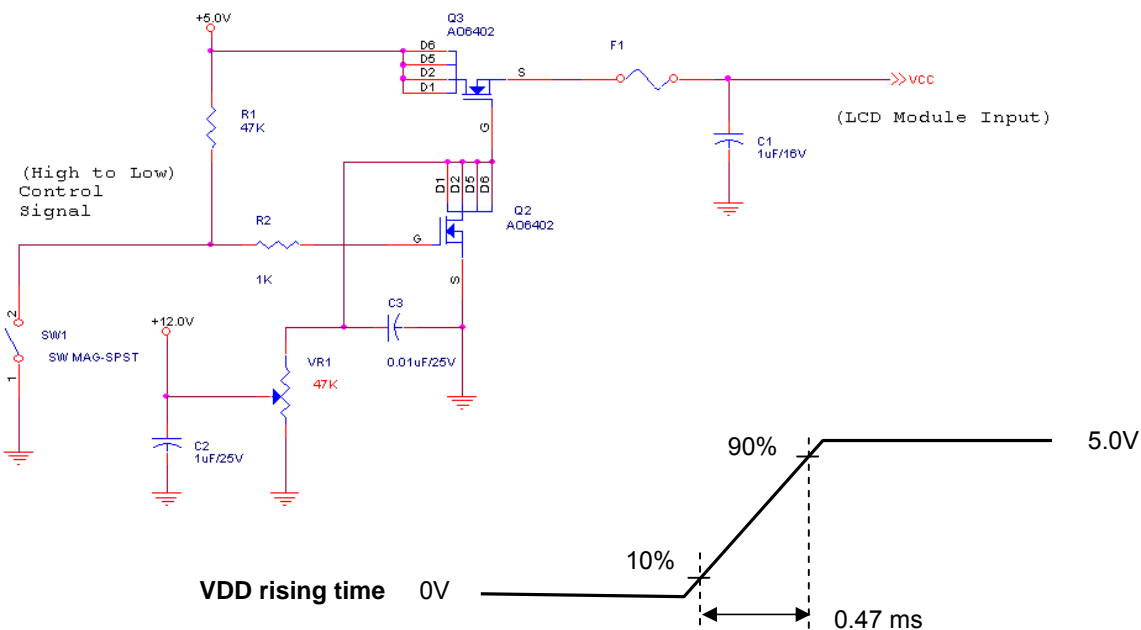

5.1.2 Signal Electrical Characteristics

Input signals shall be low or Hi-Z state when VDD is off. Please refer to specifications of SN75LVDS82DGG (Texas Instruments) in detail.

Symbol	Parameter	Min	Typ	Max	Units	Condition
V_{TH}	Differential Input High Threshold	-	-	+100	[mV]	$V_{CM} = 1.2V$, <i>Note 1</i>
V_{TL}	Differential Input Low Threshold	-100	-	-	[mV]	$V_{CM} = 1.2V$ <i>Note 1</i>
$ V_{ID} $	Input Differential Voltage	100	-	600	[mV]	<i>Note 1</i>
V_{CM}	Differential Input Common Mode Voltage	+1.0	+1.2	+1.5	[V]	$V_{TH}-V_{TL} = 200MV$ (max) <i>Note 1</i>

Note 1: LVDS Signal Waveform

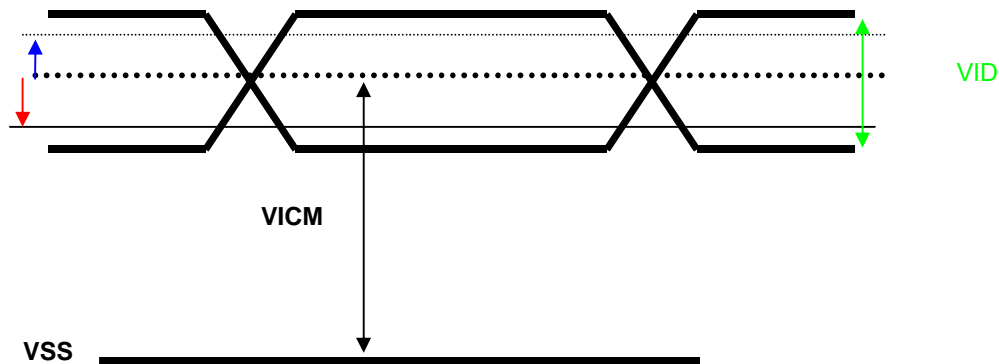

5.2 Backlight Unit

5.2.1 LED Driver

Following characteristics are measured under stable condition at 25 (Room Temperature).

Symbol	Parameter	Min	Typ	Max	Unit	Remark
VLED	Input Voltage	10.8	12	13.2	Volt	
ILED	Input Current	-	1.36	-	A	100% Dimming
PLED	Power Consumption	-	16.32	19.95	Watt	100% Dimming
Backlight Dimming (PWM Mode)	Dimming Frequency	200	-	20k	Hz	
	Swing Voltage	4.8	5	5.5	Volt	
	Dimming Duty Cycle	10	-	100	%	
Backlight Dimming (Analog Mode)	Dimming Voltage	1.5	-	5	Volt	Adjustable Dimming Range
Backlight on\off	On Control Voltage	3	-	5.5	Volt	
	Off Control Voltage	0	-	0.8	Volt	
I _F	LED Forward Current	-	80	-	mA	Ta = 25°C, Note1
Operating Life		50000	-	-	Hrs	Ta = 25°C, Note4

Note 1: Ta means ambient temperature.

Note 2: If module is driven by high current or at high ambient temperature & humidity condition. The operating life will be reduced.

Note 3: LED light bar structure: (5 strings x 13pcs / string =65pcs LED)

Note 4: Operating life means brightness goes down to 50% initial brightness. Typical operating life time is estimated data.

6.2 Signal Description

The module using a pair of LVDS receiver SN75LVDS82(Texas Instruments) or compatible. LVDS is a differential signal technology for LCD interface and high speed data transfer device. Transmitter shall be SN75LVDS83(negative edge sampling) or compatible. The first LVDS port(RxOxxx) transmits odd pixels while the second LVDS port(RxExxx) transmits even pixels.

PIN #	SIGNAL NAME	DESCRIPTION
1	RXinO0-	Negative LVDS differential data input (Odd data)
2	RXinO0+	Positive LVDS differential data input (Odd data)
3	RXinO1-	Negative LVDS differential data input (Odd data)
4	RXinO1+	Positive LVDS differential data input (Odd data)
5	RXinO2-	Negative LVDS differential data input (Odd data, H-Sync, V-Sync, DSPTMG)
6	RXinO2+	Positive LVDS differential data input (Odd data, H-Sync, V-Sync, DSPTMG)
7	GND	Power Ground
8	RxOCLKIN-	Negative LVDS differential clock input (Odd clock)
9	RxOCLKIN+	Positive LVDS differential clock input (Odd clock)
10	RXinO3-	Negative LVDS differential data input (Odd data)
11	RXinO3+	Positive LVDS differential data input (Odd data)
12	RXinE0-	Negative LVDS differential data input (Even data)
13	RXinE0+	Positive LVDS differential data input (Even data)
14	GND	Power Ground
15	RXinE1-	Negative LVDS differential data input (Even data)
16	RXinE1+	Positive LVDS differential data input (Even data)
17	GND	Power Ground
18	RXinE2-	Negative LVDS differential data input (Even data)
19	RXinE2+	Positive LVDS differential data input (Even data)
20	RxECLKIN-	Negative LVDS differential clock input (Even clock)
21	RxECLKIN+	Positive LVDS differential clock input (Even clock)
22	RXinE3-	Negative LVDS differential data input (Even data)
23	RXinE3+	Positive LVDS differential data input (Even data)
24	GND	Power Ground
25	NC	No connection (for AUO test only. Do not connect)
26	NC	No connection (for AUO test only. Do not connect)
27	NC	No connection (for AUO test only. Do not connect)
28	VDD	Power +5V
29	VDD	Power +5V
30	VDD	Power +5V

6.3 The Input Data Format

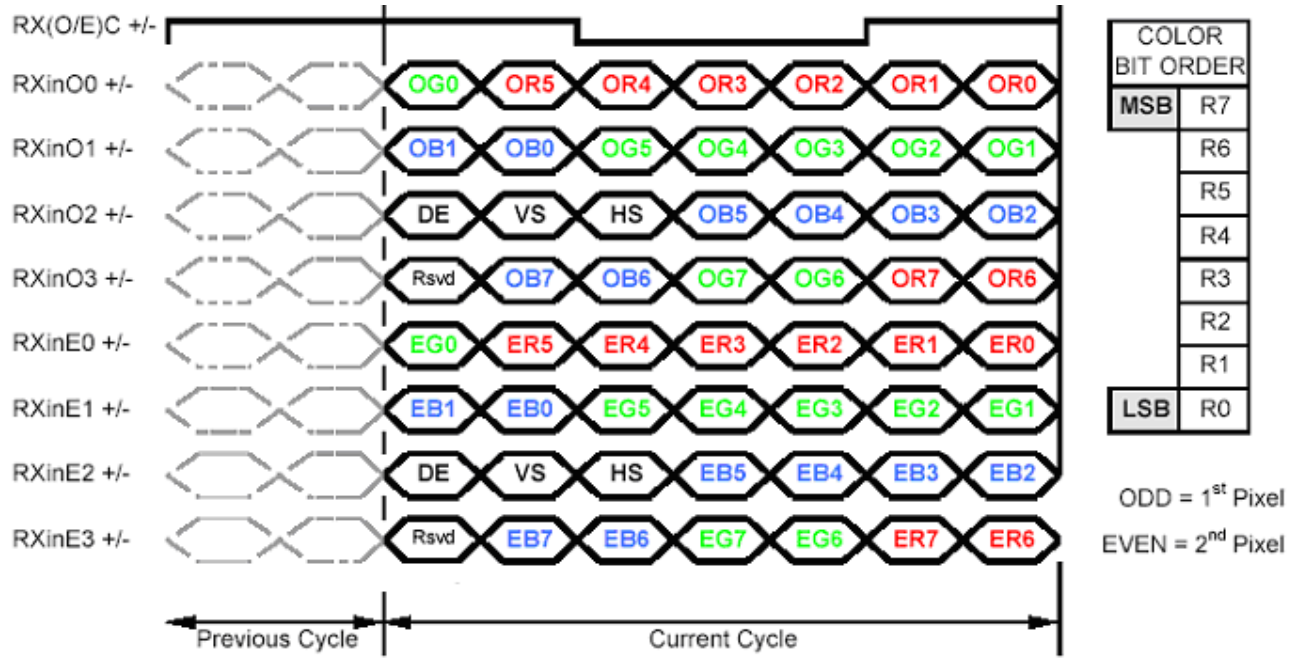

Note1: 8-bits signal input.

Note2: L:NS alike H:Thine alike

6.4 Interface Timing

6.4.1 Timing Characteristics

Signal	Item	Symbol	Min	Typ	Max	Unit
Clock	Frequency	$1/T_{\text{Clock}}$	40	72	83	MHz
Frame Rate	Frequency	F	50	60	75	Hz
Vertical Section	Period	T_V	1092	1130	1653	T_line
	Active	T_{VD}	1080	1080	1080	
	Blanking	T_{VB}	12	50	573	
Horizontal Section	Period	T_H	1004	1050	1100	T_clock
	Active	T_{HD}	960	960	960	
	Blanking	T_{HB}	44	90	140	

Note: DE mode only.

Note: Typical value refer to VESA STANDARD

6.4.2 Input Timing Diagram

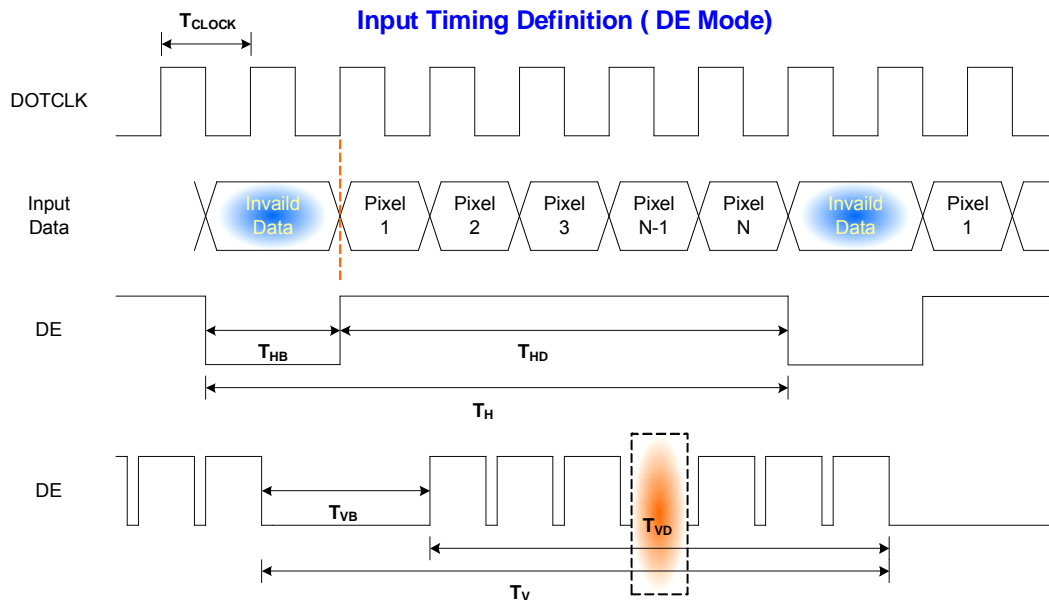

6.5 Power ON/OFF Sequence

VDD power and B/L on/off sequence is as below. Interface signals are also shown in the chart. Signals from any system shall be Hi-Z state or low level when VDD is off.

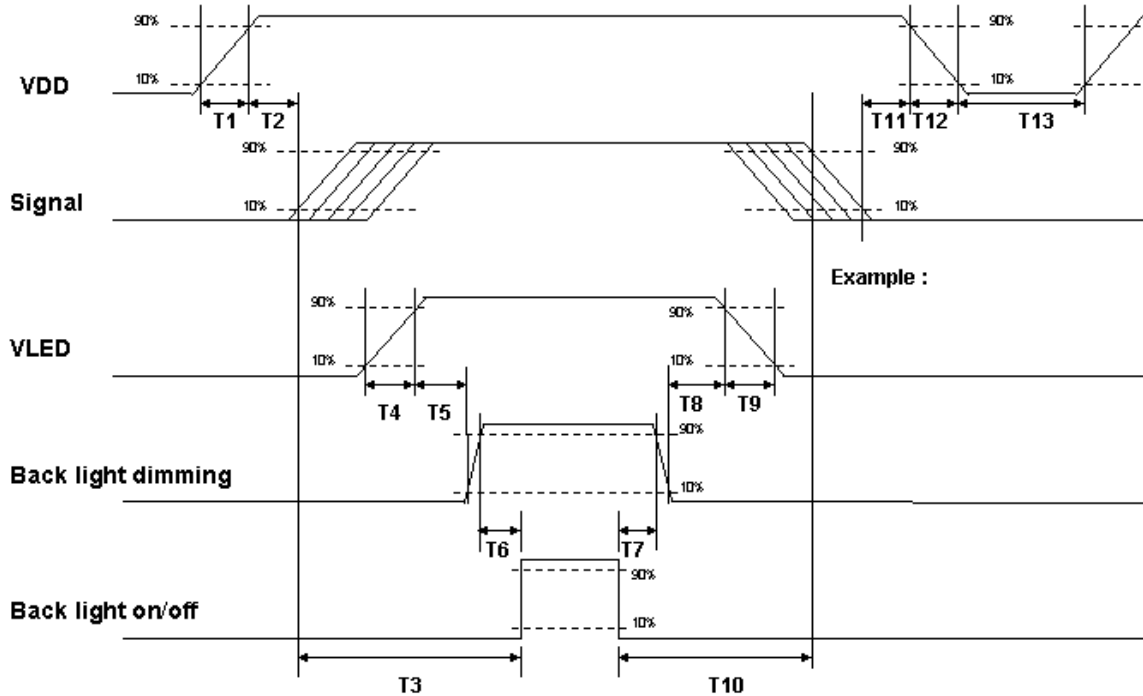

Power ON/OFF sequence timing

Parameter	Value			Units
	Min.	Typ.	Max.	
T1	0.5	--	10	[ms]
T2	30	40	50	[ms]
T3	200	--	--	[ms]
T4	0.5	--	10	[ms]
T5	10	--	--	[ms]
T6	10	--	--	[ms]
T7	0	--	--	[ms]
T8	10	--	--	[ms]
T9	--	--	10	[ms]
T10	110	--	--	[ms]
T11	0	16	50	[ms]
T12	--	--	10	[ms]
T13	1000	--	--	[ms]

The above on/off sequence should be applied to avoid abnormal function in the display. Please make sure to turn off the power when you plug the cable into the input connector or pull the cable out of the connector.

7. Connector & Pin Assignment

Physical interface is described as for the connector on module. These connectors are capable of accommodating the following signals and will be following components.

7.1 TFT LCD Module: LVDS Connector

Connector Name / Designation	Interface Connector / Interface card
Manufacturer	JAE or compatible
Type Part Number	JAE (FI-XB30SRL-HF11) or equivalent
Mating Housing Part Number	FI-X30HL (JAE) or compatible

Pin#	Signal Name	Pin#	Signal Name
1	RxOIN0-	2	RxOIN0+
3	RxOIN1-	4	RxOIN1+
5	RxOIN2-	6	RxOIN2+
7	GND	8	RxOCLKIN-
9	RxOCLKIN+	10	RxOIN3-
11	RxOIN3+	12	RxEIN0-
13	RxEIN0+	14	GND
15	RxEIN1-	16	RxEIN1+
17	GND	18	RxEIN2-
19	RxEIN2+	20	RxECLKIN-
21	RxECLKIN+	22	RxEIN3-
23	RxEIN3+	24	GND
25	NC	26	NC
27	NC	28	VDD
29	VDD	30	VDD

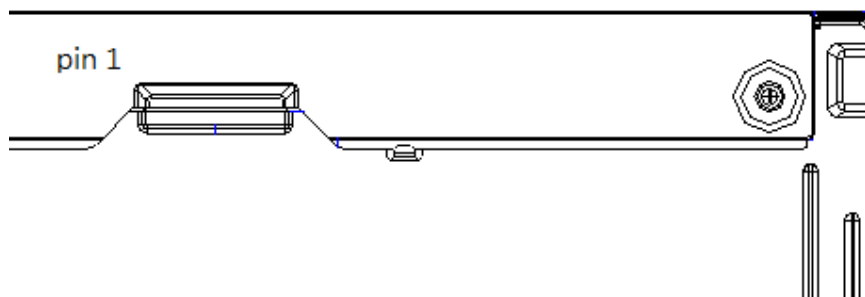

7.2 Backlight Unit: LED Connector

Connector Name / Designation	LED Connector
Manufacturer	Sin Sheng or compatible
Connector Model Number	MS24049HJ or equivalent
Mating Model Number	P24049 or compatible

PIN #	SIGNAL NAME	DESCRIPTION
1	GND	Ground
2	GND	Ground
3	GND	Ground
4	BL_DIM_P	Back light dimming
5	BL_EN	Back light enable
6	---	NC
7	VLED	Input voltage, 12V
8	VLED	Input voltage, 12V
9	VLED	Input voltage, 12V

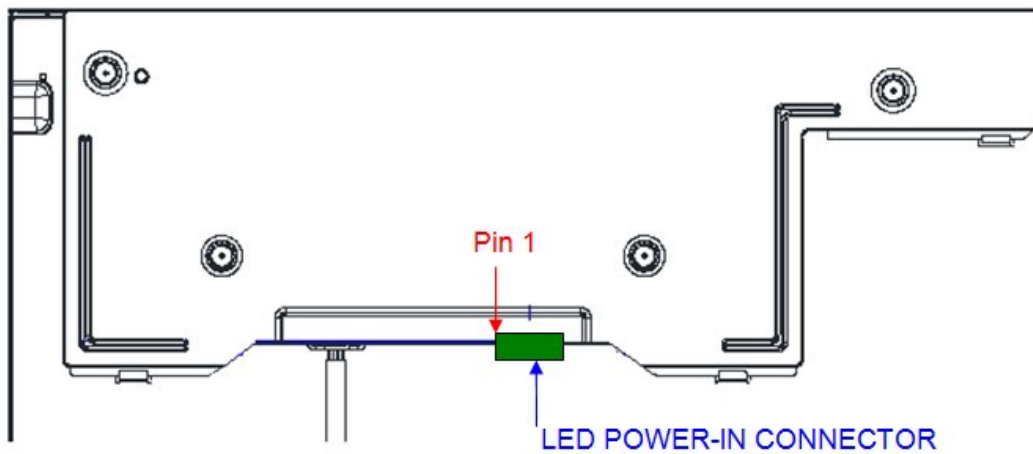



8. Reliability Test

Environment test conditions are listed as following table.

Items	Required Condition	Note
Temperature Humidity Bias (THB)	Ta= 50 , 80%RH, 300hours	
High Temperature Operation (HTO)	Ta= 60 , 300hours	
Low Temperature Operation (LTO)	Ta= 0 , 300hours	
High Temperature Storage (HTS)	Ta= 60 , 300hours	
Low Temperature Storage (LTS)	Ta= -20 , 300hours	
Vibration Test (Non-operation)	Acceleration: 1.5 Grms Wave: Random Frequency: 10 - 200 Hz Duration: 30 Minutes each Axis (X, Y, Z)	
Shock Test (Non-operation)	Acceleration: 50 G Wave: Half-sine Active Time: 20 ms Direction: ±X, ±Y, ±Z (one time for each Axis)	
Drop Test	Height: 46 cm, package test	
Thermal Shock Test (TST)	-20 /30min, 60 /30min, 100 cycles	1
On/Off Test	On/10sec, Off/10sec, 30,000 cycles	
ESD (Electro Static Discharge)	Contact Discharge: ± 8KV, 150pF(330Ω) 1sec, 15 points, 25 times/ point.	2
	Air Discharge: ± 15KV, 150pF(330Ω) 1sec 15 points, 25 times/ point.	
Altitude Test	Operation:10,000 ft Non-Operation:30,000 ft	

Note 1: The TFT-LCD module will not sustain damage after being subjected to 100 cycles of rapid temperature change. A cycle of rapid temperature change consists of varying the temperature from -20 to 60 , and back again. Power is not applied during the test. After temperature cycling, the unit is placed in normal room ambient for at least 4 hours before power on.

Note2: According to EN61000-4-2, ESD class B: Some performance degradation allowed. No data lost Self-recoverable. No hardware failures.

9. Mechanical Characteristics

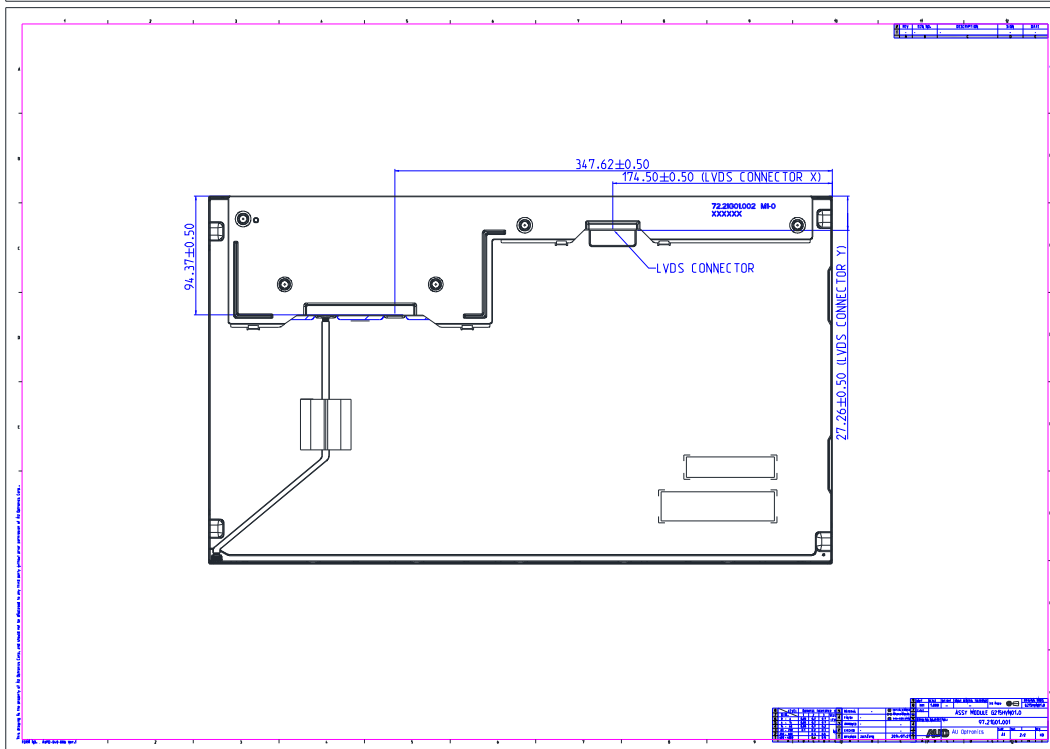
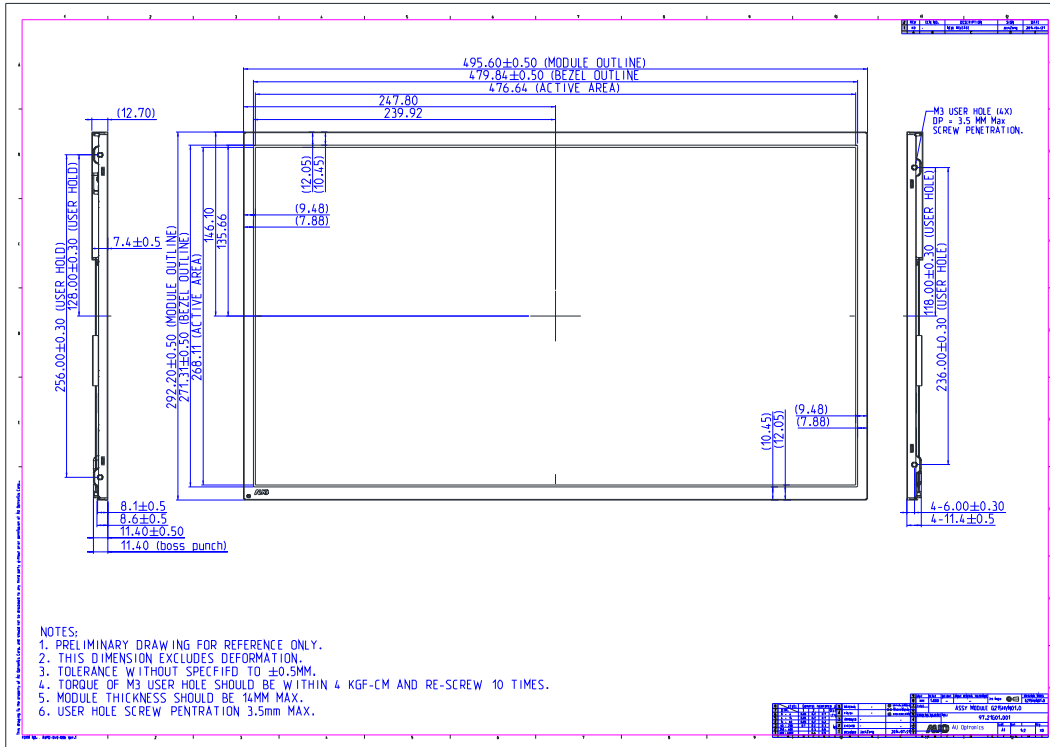

10. Label and Packaging

10.1 Shipping Label (on the rear side of TFT-LCD display)

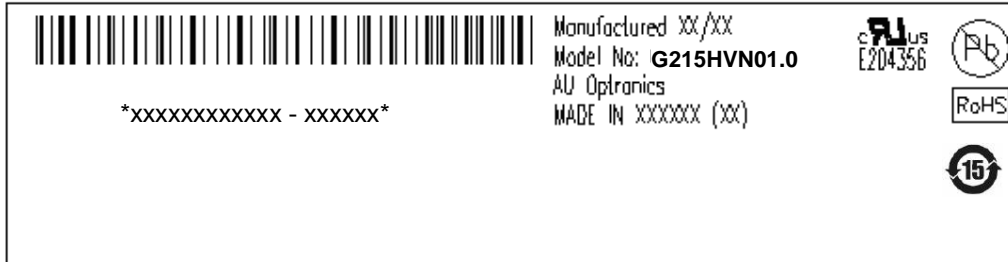

10.2 Carton Package

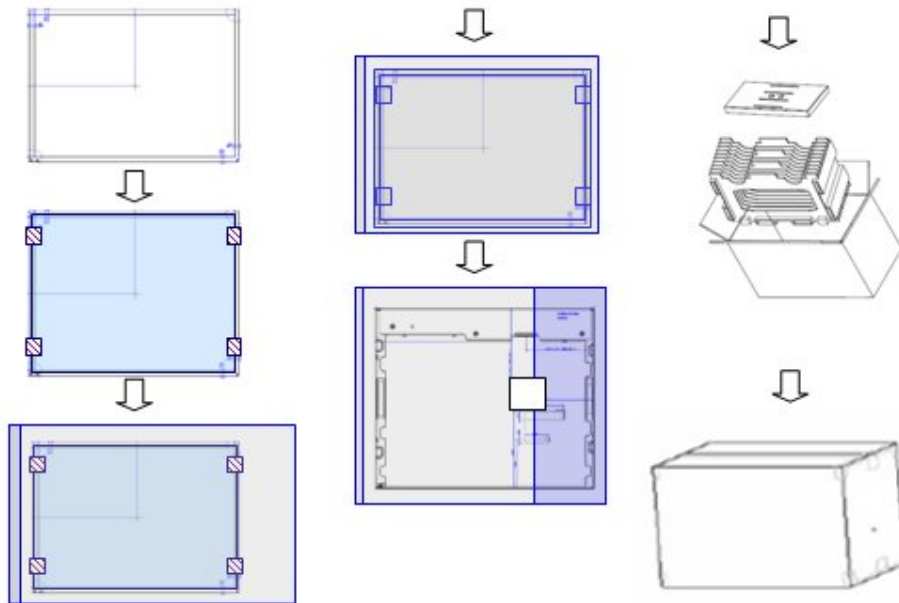

Max capacity : 9 pcs per carton

Max weight: 20.7 kg per carton

Outside dimension of carton: 570mm*275mm*395mm

Pallet size : 1150mm*840mm*132mm

Box stacked:

Module by air : (2 *3) *3 layers , one pallet put 18 boxes , total 162pcs.

Module by sea (I) : One pallet (2 *3) *3 layers + One pallet (2 *3) *1 layers , total 216 pcs.

Module by sea (II) : One pallet (2 *3) *3 layers + One pallet (2 *3) *2 layers , Total 270 pcs.



11. Safety

11.1 Sharp Edge Requirements

There will be no sharp edges or comers on the display assembly that could cause injury.

11.2 Materials

11.2.1 Toxicity

There will be no carcinogenic materials used anywhere in the display module. If toxic materials are used, they will be reviewed and approved by the responsible AUO toxicologist.

11.2.2 Flammability

All components including electrical components that do not meet the flammability grade UL94-V1 in the module will complete the flammability rating exception approval process.

The printed circuit board will be made from material rated 94-V1 or better. The actual UL flammability rating will be printed on the printed circuit board.

11.3 Capacitors

If any polarized capacitors are used in the display assembly, provisions will be made to keep them from being inserted backwards.

11.4 National Test Lab Requirement

The display module will satisfy all requirements for compliance to:

UL 1950, First Edition

U.S.A. Information Technology Equipment