

**PROPRIETARY NOTE**

THIS SPECIFICATION IS THE PROPERTY OF BOE SDT AND SHALL NOT BE REPRODUCED OR COPIED WITHOUT THE WRITTEN PERMISSION OF BOE SDT AND MUST BE RETURNED TO BOE SDT UPON ITS REQUEST



SPEC. NUMBERS

PRODUCT GROUP

Rev.

ISSUE DATE

PAGE

TFT-LCM

P0.1

2020.03.20

1 OF 23

**TITLE : RV101FBB-N00**

**Product Specification**

**P0.1**

ITEM	SIGNATURE	ITEM	SIGNATURE		
Prepared	张祥杰	Checked			
Approved					

**BEIJING BOE SPECIAL DISPLAY TECHNOLOGY**



## Contents

<b>No.</b>	<b>Items</b>	<b>Page</b>
1.0	General Description	4
2.0	Absolute Maximum ratings	6
3.0	Electrical specifications.	7
4.0	Optical specifications.	9
5.0	Interface Connection	12
6.0	Signal Timing Specifications	15
7.0	Input Signals, Display Colors & Gray Scale of Colors	16
8.0	Power Sequence	17
9.0	Mechanical Characteristics	18
10.0	Reliability Test	19
11.0	Handling & Cautions.	20
12.0	Label	21
13.0	Packing information	22
14.0	Mechanical Outline Dimension	23

## 1.0 GENERAL DESCRIPTION

### 1.1 Introduction

10.1 MONO is a active matrix TFT-LCD using amorphous silicon TFT's(Thin Film Transistors) as an active switching devices. This model is composed of a TFT-LCD Panel and a driving circuit. It is a transmission type display operating in the normal black. This TFT-LCD has a 10.1 inch diagonally measured active area with UHD resolutions (4920\*1 horizontal by 2880 vertical pixel array).

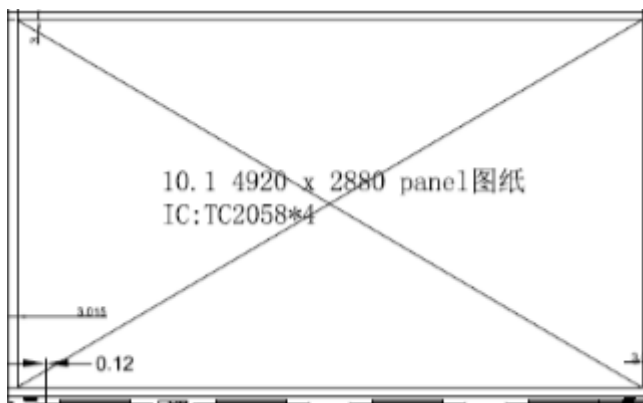

### 1.2 Features

- MONO LCD
- High resolution
- GOA Design
- High contrast ratio
- Anti UV
- EDP interface

### 1.3 Application

- UV curing 3D printing Tech
- Industrial

**1.4 General Specification**

The followings are general specifications at the LCD RV101FBB-N00.

< Table 1. General Specifications >

Parameter	Specification	Unit	Remarks
Active area	221.4 (H) × 129.6(V)	mm	
Number of pixels	4920 (H) × 1 × 2880(V)	Pixels	
Pixel pitch	0.045(H) × 0.045 (V)	mm	
Pixel arrangement	MONO		
TFT Type	a-si		
Display colors	MONO	Colors	8bit
Display mode	Normally Black		
Viewing Angle (Human Eye )	U/D/L/R : 80/80/80/80	Deg	
Dimensional outline	227.43±0.15 (H) × 139.5±0.15 (V) × 2.5(PCBA MAX)	mm	
Weight	TBD	kg	
Surface treatment	Haze 25%, 3H		
Luminance	TBD	cd/m <sup>2</sup>	White
Contrast	TBD		
Crosstalk	TBD		
LCD Response time(Tr+Tf)	TBD	ms	

**2.0 ABSOLUTE MAXIMUM RATINGS**

The followings are maximum values which, if exceed, may cause faulty operation or damage to the unit. Make sure all the design characteristics are adequate before the panel is initialed. All the measurements should be operated with driver IC and experimental FPC mounted.

&lt; Table 2. LCD Module Electrical Specifications &gt;

[Ta =25±2 °C]

Parameter	Symbol	Min	Max	Unit	Remark
Operating Voltage	Vop	2.5	5.5	V	Ta = 25°C
Operating Temperature	TOP	0	+70	°C	
Storage Temperature	TST	-10	+80	°C	

### 3.0 ELECTRICAL SPECIFICATIONS

#### 3.1 TFT LCD Module

[Ta =25 ± 2 °C]

&lt; Table 3. TFT LCD specifications &gt;

Parameter	Symbol	Value			Unit	Remark
		min	typ	max		
Power Supply Voltage	VDD	2.5	3.3	5.5	V	
Power Supply Current	IDD	-	TBD	0.8	A	VDD=3.3V
Power Consumption	PD	-	TBD	2.64	W	VDD=3.3V
In-Rush Current	IRUSH	-	TBD	1	A	
Permissible Input Ripple Voltage	VRF	-	-	300	mV	VDD=3.3V
High Level Differential Input Threshold Voltage	VIH	-	-	+100	mV	
Low Level Differential Input Threshold Voltage	VIL	-100	-	-	mV	
Differential input voltage	VID	100	-	600	mV	
Differential input common mode voltage	Vcm	0	-	2	V	VIH=+100mV VIL=-100mV

## 4.0 OPTICAL SPECIFICATION

### 4.1 Overview

The test of view angle range shall be measured in a dark room (ambient luminance  $\leq 1$ lux and temperature =  $25 \pm 2^\circ\text{C}$ ) with the equipment of Luminance meter system (PR-655 and CS-2000A) and test unit shall be located at an approximate distance 50cm from the LCD surface at a viewing angle of  $\theta$  and  $\Phi$  equal to  $0^\circ$ . We refer to  $\theta_{\phi=0}$  ( $=\theta_3$ ) as the 3 o'clock direction (the "right"),  $\theta_{\phi=90}$  ( $=\theta_{12}$ ) as the 12 o'clock direction ("upward"),  $\theta_{\phi=180}$  ( $=\theta_9$ ) as the 9 o'clock direction ("left") and  $\theta_{\phi=270}$  ( $=\theta_6$ ) as the 6 o'clock direction ("bottom"). While scanning  $\theta$  and/or  $\Phi$ , the center of the measuring spot on the Display surface shall stay fixed. The luminance, color and uniformity (etc) should be tested by CS-2000A. The backlight should be operating for 10 minutes prior to measurement. VDD shall be  $3.3 \pm 0.3\text{V}$  at  $25^\circ\text{C}$ . Optimum viewing angle direction is 6 'clock

<Table 5. Optical Specifications>

Parameter		Symbol	Condition	Min.	Typ.	Max.	Unit	Remark
Viewing Angle range	Horizontal	$\Theta_3$	CR > 10	80	-	-	Deg.	Note 1
		$\Theta_9$		80	-	-	Deg.	
	Vertical	$\Theta_{12}$		80	-	-	Deg.	
		$\Theta_6$		80	-	-	Deg.	
Luminance Contrast ratio		CR	$\Theta = 0^\circ$	400	-	-		Note 2
Transmittance				4.5	6	-	%	Note 3
White Luminance uniformity	9 Points	$\Delta Y_9$	$\Theta = 0^\circ$			-	%	Note 4
Reproduction of color	White	$W_x$	$\Theta = 0^\circ$					Note 5
		$W_y$						
	Red	$R_x$						
		$R_y$						
	Green	$G_x$						
		$G_y$						
	Blue	$B_x$						
		$B_y$						
Response Time		$T_{RT}$	Ta= $25^\circ\text{C}$ $\Theta = 0^\circ$	-	-	35	ms	Note 6
Cross Talk		CT	$\Theta = 0^\circ$	-	-	2.0	%	Note 7
Colour Gamut			NTSC 1976		-	-	%	

Notes : 1. Viewing angle is the angle at which the contrast ratio is greater than 10. The viewing angles are determined for the horizontal or 3, 9 o'clock direction and the vertical or 6, 12 o'clock direction with respect to the optical axis which is normal to the LCD surface (see FIGURE 1).

2. Contrast measurements shall be made at viewing angle of  $\Theta = 0$  and at the center of the LCD surface. Luminance shall be measured with all pixels in the view field set first to white, then to the dark (black) state. (see FIGURE 1) Luminance Contrast Ratio (CR) is defined mathematically.

$$CR = \frac{\text{Luminance when displaying a white raster}}{\text{Luminance when displaying a black raster}}$$

3. It is based on UV405nm.

4. The White luminance uniformity on LCD surface is then expressed as :  $\Delta Y = \text{Minimum Luminance of 9 points} / \text{Maximum Luminance of 9 points}$  (see FIGURE 2).

5. The color chromaticity coordinates specified in Table 5. shall be calculated from the spectral data measured with all pixels first in red, green, blue and white. Measurements shall be made at the center of the panel.

6. The electro-optical response time measurements shall be made as FIGURE 3 by switching the "data" input signal ON and OFF. The times needed for the luminance to change from 10% to 90% is  $T_r$ , and 90% to 10% is  $T_d$ .

7. Cross-Talk of one area of the LCD surface by another shall be measured by comparing the luminance ( $Y_A$ ) of a 25mm diameter area, with all display pixels set to a gray level, to the luminance ( $Y_B$ ) of that same area when any adjacent area is driven dark. (See FIGURE 4).

## 4.2 Optical measurements

**Figure 1. Measurement Set Up**

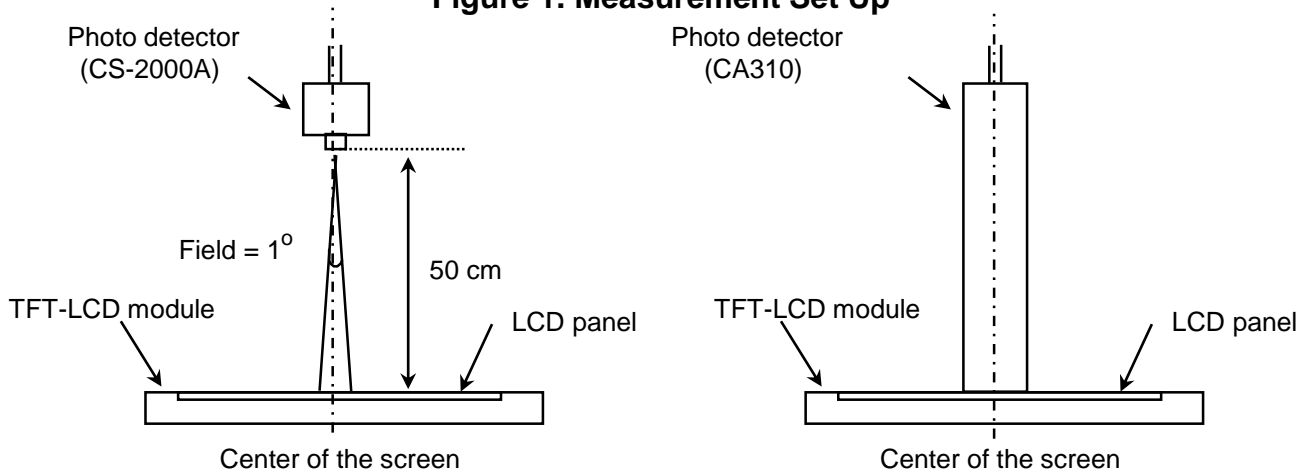

View angel range, uniformity, etc. measurement setup      Flicker, measurement setup

**Figure 2. White Luminance and Uniformity Measurement Locations (9 points)**

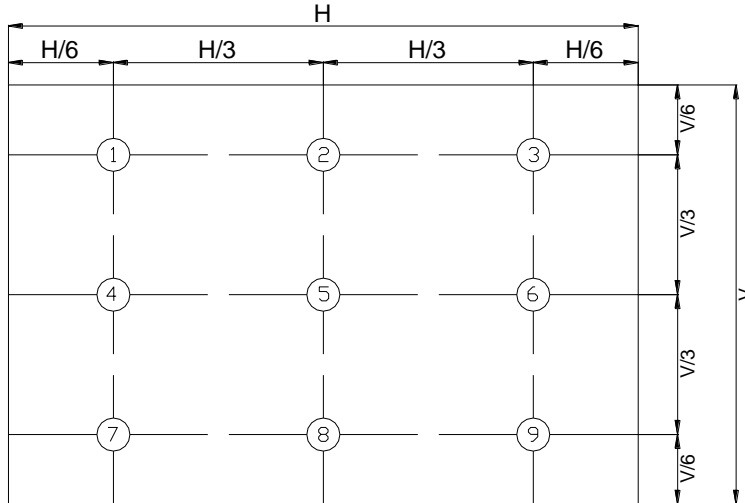

Luminance of white is defined as luminance values of max 9 points across the LCD surface. Luminance shall be measured with all pixels in the view field set first to white. This measurement shall be taken at the locations shown in FIGURE 2 for a total of the measurements per display.

The White luminance uniformity on LCD surface is then expressed as :  $\Delta Y9 = \text{Minimum Luminance of 9 points} / \text{Maximum Luminance of 9points}$  (see FIGURE 2).

### Figure 3. Response Time Testing

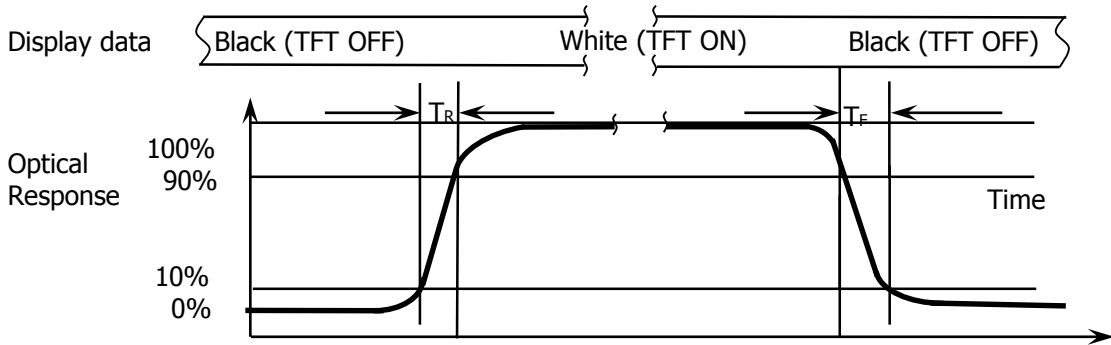

The electro-optical response time measurements shall be made as shown in FIGURE 3 by switching the “data” input signal ON and OFF. The times needed for the luminance to change from 10% to 90% is  $T_r$  and 90% to 10% is  $T_d$ .

### Figure 4. Cross Modulation Test Description

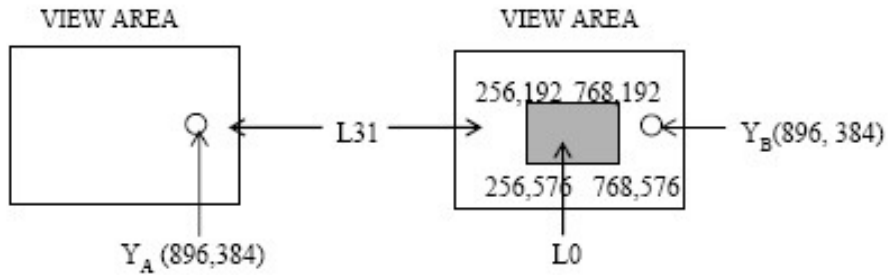

$$\text{Cross-Talk (\%)} = \left| \frac{Y_B - Y_A}{Y_A} \right| \times 100$$

Where:

$Y_A$  = Initial luminance of measured area (cd/m<sup>2</sup>)

$Y_B$  = Subsequent luminance of measured area (cd/m<sup>2</sup>)

The location measured will be exactly the same in both patterns

## 5.0 INTERFACE CONNECTION.

### 5.1 Electrical Interface Connection

Main interface connector: 40 pin main connector 20455-040E-66 (IPEX) or similar type; 3.3V input power supply.

The main connector interface pin assignments are listed in table1

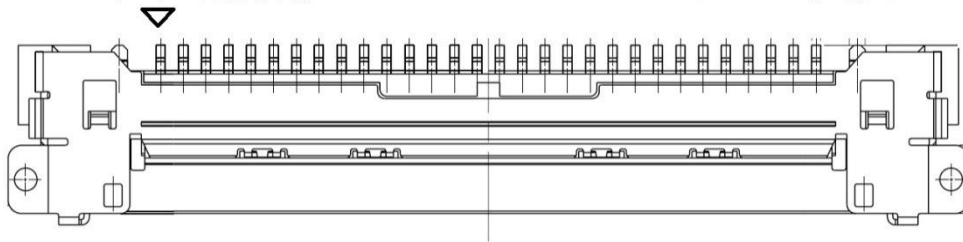

<Table 6. Pin Assignments for the Interface Connector>

&lt;Table 6. Pin Assignments for the Interface Connector (Sequel) &gt;

Pin No	Sym bol	Function s	Pin No	Sym bol	Functions	Pin No	Sym bol	Function s	Pin No	Sym bol	Functions
1	LED-	LED Negative Pole	11	LED+	LED Positive Pole	21	LCD_VCC	Power Supply (3.3V)	31	LANE1_P	Lane3P True Signal for Main Link 1
2	LED-	LED Negative Pole	12	NC	No connection	22	LCD_VCC	Power Supply (3.3V)	32	LANE1_N	Lane3N Component Signal for Main Link 1
3	LED-	LED Negative Pole	13	NC	No connection	23	LCD_VCC	Power Supply (3.3V)	33	GND	Ground
4	LED-	LED Negative Pole	14	HPD	HPD signal pin	24	GND	Ground	34	LANE2_P	Lane3P True Signal for Main Link 2
5	NC	No connection	15	GND	Ground	25	AUX_CH_N	AUX_CHN Component Signal for Auxiliary Channel	35	LANE2_N	Lane3N Component Signal for Main Link 2
6	NC	No connection	16	GND	Ground	26	AUX_CH_P	AUX_CHP True Signal for Auxiliary Channel	36	GND	Ground
7	NC	No connection	17	GND	Ground	27	GND	Ground	37	LANE3_P	Lane3P True Signal for Main Link 3
8	LED+	LED Positive Pole	18	GND	Ground	28	LANEO_P	Lane3P True Signal for Main Link 0	38	LANE3_N	Lane3N Component Signal for Main Link 3
9	LED+	LED Positive Pole	19	LCD_TEST	BISTEN	29	LANEO_N	Lane3N Component Signal for Main Link 0	39	GND	Ground
10	LED+	LED Positive Pole	20	LCD_VCC	Power Supply (3.3V)	30	GND	Ground	40	NC	No connection

## 5.2 Edp Interface

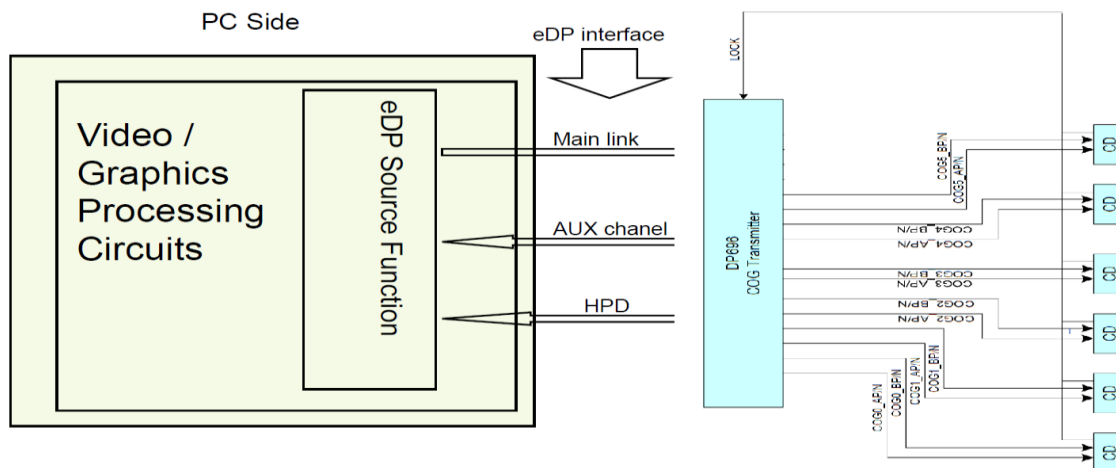

Note: TCON(DP667), Source IC(TC2058\*4)

## 6.0 SIGNAL TIMING SPECIFICATION

DE mode only

Parameter	Symble	Typ	Unit
DCLK frequency	$1/T_c$	-	MHz
Frame frequency	$F_v$	60	Hz
Vertical total timing	$T_v$	2942	lines
Vertical active timing	$T_{vd}$	2880	lines
Horizontal total timing	$T_h$	1800	clocks
Horizontal active timing	$T_{hd}$	1640	clocks
Horizontal start timing	TS	112	clocks
Vertical start timing	VS	16	lines

### 6.1 SIGNAL INPUT TIMING

#### Horizontal Timing Chant

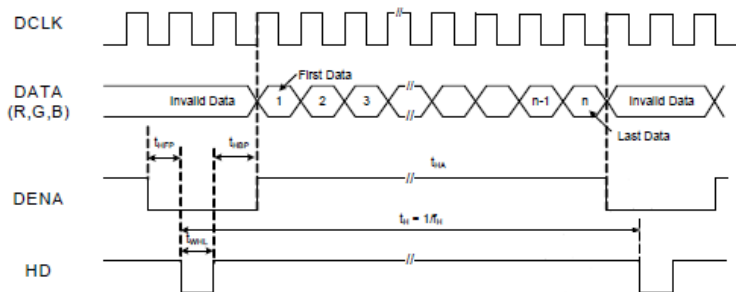

#### Vertical Timing Chant

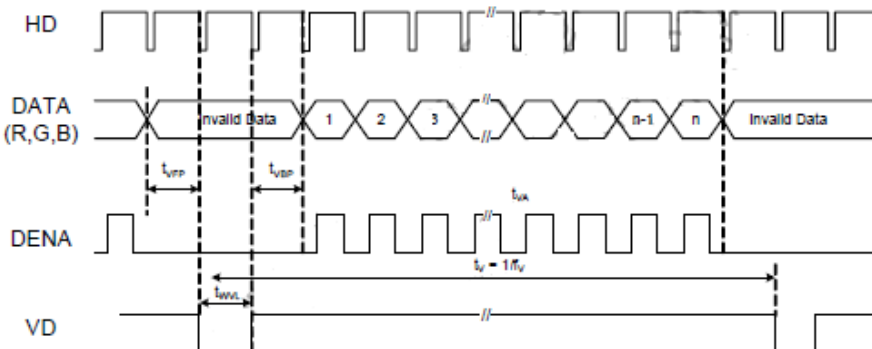

## 7.0 Input Signals Display Colors & Gray Scale of Colors

The brightness of each primary color (red, green and blue) is based on the 8-bit gray scale data input for the color. The higher the binary input, the brighter the color. The table below provides the assignment of color versus data input

Color & Gray Scale		RED DATA								GREEN DATA								BLUE DATA							
		R7	R6	R5	R4	R3	R2	R1	R0	G7	G6	G5	G4	G3	G2	G1	G0	B7	B6	B5	B4	B3	B2	B1	B0
Basic Colors	Black	0	0	0	0	0	0	0	0	0	0	0	0	0	0	0	0	0	0	0	0	0	0	0	0
	Blue	0	0	0	0	0	0	0	0	0	0	0	0	0	0	0	0	1	1	1	1	1	1	1	1
	Green	0	0	0	0	0	0	0	0	1	1	1	1	1	1	1	1	0	0	0	0	0	0	0	0
	Cyan	0	0	0	0	0	0	0	0	1	1	1	1	1	1	1	1	1	1	1	1	1	1	1	1
	Red	1	1	1	1	1	1	1	1	0	0	0	0	0	0	0	0	0	0	0	0	0	0	0	0
	Magenta	1	1	1	1	1	1	1	1	0	0	0	0	0	0	0	0	1	1	1	1	1	1	1	1
	Yellow	1	1	1	1	1	1	1	1	1	1	1	1	1	1	1	1	0	0	0	0	0	0	0	0
	White	1	1	1	1	1	1	1	1	1	1	1	1	1	1	1	1	1	1	1	1	1	1	1	1
Gray Scale of RED	Black	0	0	0	0	0	0	0	0	0	0	0	0	0	0	0	0	0	0	0	0	0	0	0	0
	△	0	0	0	0	0	0	0	1	0	0	0	0	0	0	0	0	0	0	0	0	0	0	0	0
	Darker	0	0	0	0	0	0	1	0	0	0	0	0	0	0	0	0	0	0	0	0	0	0	0	0
	△																								
	▽																								
	Brighter	1	1	1	1	1	1	0	1	0	0	0	0	0	0	0	0	0	0	0	0	0	0	0	0
Gray Scale of GREEN	Black	0	0	0	0	0	0	0	0	0	0	0	0	0	0	0	0	0	0	0	0	0	0	0	0
	△	0	0	0	0	0	0	0	0	0	0	0	0	0	0	0	0	1	0	0	0	0	0	0	0
	Darker	0	0	0	0	0	0	0	0	0	0	0	0	0	0	0	0	1	0	0	0	0	0	0	0
	△																								
	▽																								
	Brighter	0	0	0	0	0	0	0	0	1	1	1	1	1	1	0	1	0	0	0	0	0	0	0	0
Gray Scale of BLUE	Black	0	0	0	0	0	0	0	0	0	0	0	0	0	0	0	0	0	0	0	0	0	0	0	0
	△	0	0	0	0	0	0	0	0	0	0	0	0	0	0	0	0	0	0	0	0	0	0	0	1
	Darker	0	0	0	0	0	0	0	0	0	0	0	0	0	0	0	0	0	0	0	0	0	0	0	1
	△																								
	▽																								
	Brighter	0	0	0	0	0	0	0	0	0	0	0	0	0	0	0	0	1	1	1	1	1	1	0	1
Gray Scale of WHITE	Black	0	0	0	0	0	0	0	0	0	0	0	0	0	0	0	0	0	0	0	0	0	0	0	0
	△	0	0	0	0	0	0	1	0	0	0	0	0	0	0	0	0	1	0	0	0	0	0	0	1
	Darker	0	0	0	0	0	0	1	0	0	0	0	0	0	0	0	0	1	0	0	0	0	0	0	1
	△																								
	▽																								
	Brighter	1	1	1	1	1	1	0	1	1	1	1	1	1	1	0	1	1	1	1	1	1	1	0	1
White	1	1	1	1	1	1	1	1	1	1	1	1	1	1	1	1	1	1	1	1	1	1	1	1	

Note: 0:Low Level Voltage, 1:High Level Voltage

## 8.0 POWER SEQUENCE

To prevent a latch-up or DC operation of the Open Cell, the power on/off sequence shall be as shown in below.

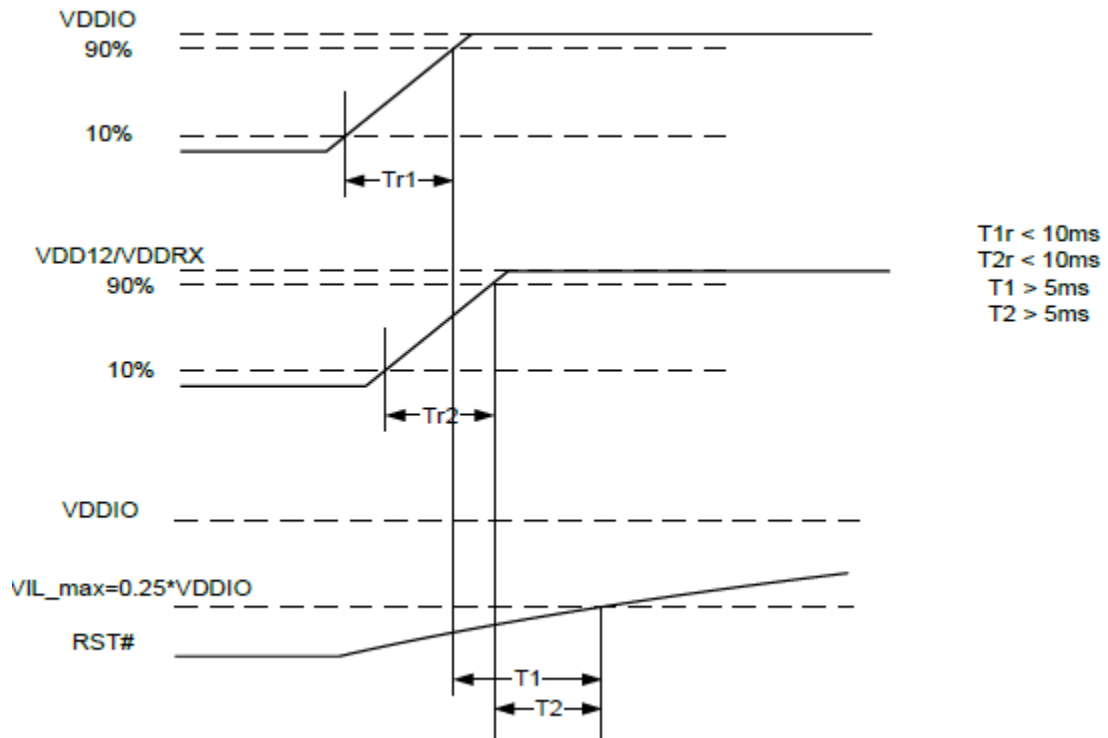

**9.0 MECHANICAL CHARACTERISTICS****9.0.1 Dimensional Requirements**

&lt;Table 7. Dimensional Parameters&gt;

Parameter	Specification	Unit
Active Area	221.4 (H) × 129.6(V)	mm
Number of pixels	4920(H)MONO × 2880(V)	pixels
Pixel pitch	0.045(H) × 0.045 (V)	mm
Pixel arrangement	MONO	
Display mode	Normally Black	
Dimensional outline	227.43±0.15 (H) × 139.5±0.15 (V) × 2.5(PCBA MAX)	mm
Weight	TBD	kg

**10.0 RELIABILITY TEST**

The Reliability test items and its conditions are shown in below.

<Table 8. Reliability test>

NO	Test Item	Test Condition	Duration
1	Low temperature storage test no-working	-10 °C	240H
2	Low temperature operation test	0°C	240H
3	High temperature storage test no-working	80°C	240H
4	High temperature operation test	70°C	240H
5	Temperature-humidity operation test	60°C 90%RH	240H
6	Thermal shock test no-working	-10°C(30min)~+80°C(30min) 100cycles(No Operation)	-

## 11.0 HANDLING & CAUTIONS

### (1) Cautions when taking out the module

- Pick the pouch only, when taking out module from a shipping package.

### (2) Cautions for handling the module

- As the electrostatic discharges may break the LCD module, handle the LCD module with care. Peel a protection sheet off from the LCD panel surface as slowly as possible.
- As the LCD panel and back - light element are made from fragile glass material, impulse and pressure to the LCD module should be avoided.
- As the surface of the polarizer is very soft and easily scratched, use a soft dry cloth without chemicals for cleaning.
- Do not pull the interface connector in or out while the LCD module is operating.
- Put the module display side down on a flat horizontal plane.
- Handle connectors and cables with care.

### (3) Cautions for the operation

- When the module is operating, do not lose CLK, ENAB signals. If any one of these signals is lost, the LCD panel would be damaged.
- Obey the supply voltage sequence. If wrong sequence is applied, the module would be damaged.

### (4) Cautions for the atmosphere

- Dew drop atmosphere should be avoided.
- Do not store and/or operate the LCD module in a high temperature and/or humidity atmosphere. Storage in an electro-conductive polymer packing pouch and under relatively low temperature atmosphere is recommended.

### (5) Cautions for the module characteristics

- Do not apply fixed pattern data signal to the LCD module at product aging.
- Applying fixed pattern for a long time may cause image sticking.

### (6) Other cautions

- Do not disassemble and/or re-assemble LCD module.
- Do not re-adjust variable resistor or switch etc.
- When returning the module for repair or etc., Please pack the module not to be broken. We recommend to use the original shipping packages.

**DUOBOND**

REV

ISSUE DATE

**BOE**

LCM PRODUCT

P0.1

2020.03.20

SPEC. NUMBER

SPEC. TITLE

PAGE

RV101FBB-N00 Preliminary Product Specification

21 OF 23

**12.0 Label**

**TBD**

**DUOBOND**

REV

ISSUE DATE

**BOE**

LCM PRODUCT

P0.1

2020.03.20

SPEC. NUMBER

SPEC. TITLE

PAGE

RV101FBB-N00 Preliminary Product Specification

22 OF 23

**13.0 Packing information**

**TBD**

## 14.0 Mechanical Outline Dimension

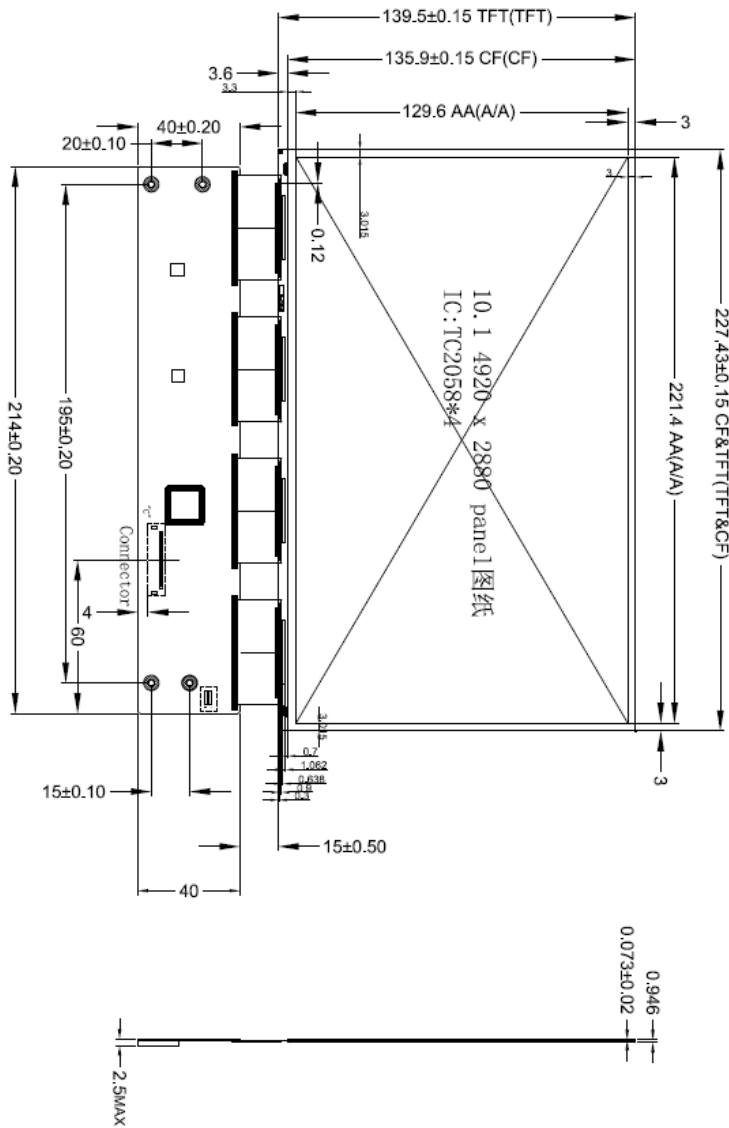

标记数量	申请书号	签名	日期	描述