

FEATURES

1. Package Type: SIP8
2. Operating Temperature Range: -40°C - +105°C
3. Isolation Voltage: 1500VDC
4. 2:1 Wide Input Voltage Range
5. With the output overcurrent protection and output short-circuit protection mechanism
6. Fields of application: electric power, industrial control, communication, Internet of Things, automobile, etc



3 years
Warranty

Selection Guide

Part No.	Input Voltage (VDC)	Output			Ripple & noise (Typ./Max.) (mVp-p)	Full Load Efficiency% (Min./Typ.)	Capacitive Load Max. (μF)
	Nominal (Range)	Voltage (VDC)	Current (mA) Max.	Current (mA) Min.			
NKB0503S-1WR2	5 (4.5-9)	3.3	303	15	70/100	66/68	1800
NKB0505S-1WR2		5	200	10		71/73	2200
NKB0512S-1WR2		12	83	4		75/77	681
NKB0515S-1WR2		15	67	3		72/74	470
NKB0524S-1WR2		24	42	2		74/76	330
NKA0505S-1WR2		±5	±100	±5		72/74	#1000
NKA0512S-1WR2		±12	±42	±2		75/77	#470
NKA0515S-1WR2		±15	±33	±2		75/77	#330
NKB1203S-1WR2	12 (9-18)	3.3	303	15	100/150	73/75	2700
NKB1205S-1WR2		5	200	10		74/76	2200
NKB1209S-1WR2		9	111	6		76/78	1000
NKB1212S-1WR2		12	83	4		80/82	680
NKB1215S-1WR2		15	67	3		81/83	471
NKB1224S-1WR2		24	42	2		79/81	330
NKA1205S-1WR2		±5	±100	±5		76/78	#1000
NKA1212S-1WR2		±12	±42	±2		77/79	#470
NKA1215S-1WR2	±15	±33	±2	78/80	#330		
NKB2403S-1WR2	24 (18-36)	3.3	303	15	70/100	72/74	2700
NKB2405S-1WR2		5	200	10		79/81	2200
NKB2412S-1WR2		12	83	4		81/83	680
NKB2415S-1WR2		15	67	3		81/83	470
NKB2424S-1WR2		24	42	2		81/83	330
NKA2405S-1WR2		±5	±100	±5		77/79	#1000
NKA2409S-1WR2		±9	±56	±3		77/79	680
NKA2412S-1WR2		±12	±42	±2		81/83	#470

NKA2415S-1WR2		±15	±33	±2		81/83	#330
NKB0503S-1WR2	48 (36-75)	3.3	303	15	100/150	73/75	2700
NKB0505S-1WR2		5	200	10		74/76	2200
NKB0512S-1WR2		12	83	4		78/80	680
NKB0515S-1WR2		15	67	3		82/84	470
NKB0524S-1WR2		±5	±100	±5		77/79	#1000
NKA0505S-1WR2		±12	±42	±2		80/82	#470
NKA0512S-1WR2		±15	±33	±2		80/82	#330

each output

Input Specifications

Item	Operating Conditions	Min.	Typ.	Max.	Unit
Input Current (full load/no load)	5VDC input	--	281/40	290/60	mA
	12VDC input	--	111/15	114/30	
	24VDC input	--	55/6	57/10	
	48VDC input	--	27/4	28/6	
Reflected Ripple Current	5VDC input	--	30	--	
	12VDC input	--	40	--	
	24VDC input	--	55	--	
	48VDC input	--	4	--	
Impulse Voltage	5VDC input	-0.7	--	12	VDC
	12VDC input	-0.7	--	25	
	24VDC input	-0.7	--	50	
	48VDC input	-0.7	--	100	
Starting Voltage	5VDC input	--	--	4.5	
	12VDC input	--	--	9	
	24VDC input	--	--	18	
	48VDC input	--	--	36	
Input Filter		Capacitance Filter			
Hot Plug		Unavailable			
CTRL	Module off	0-0.7V turn off			
	Module on	No connect or 3.5-12V on			

Output Specifications

Item	Operating Conditions	Min.	Typ.	Max.	Unit
Output Voltage Accuracy	5% - 100% Load, Input Voltage Range	--	±1.0	±3.0	%
No-load Output Voltage Accuracy	Input Voltage Range	--	±1.5	±5.0	
Linear Regulation	Full load, Input voltage from low limit to high	--	±0.2	±0.5	
Load Regulation	5% - 100% Load	--	±0.4	±0.75	
Transient Recovery Time	25% load step change	--	0.5	2	ms
Transient Response Deviation		--	±2.5	±5	%
Temperature Coefficient	Full Load	--	±0.02	±0.03	%/°C
Short-circuit Protection		Continuous, Self-Recovery			

General Specifications

Item	Operating Conditions	Min.	Typ.	Max.	Unit
Insulation Voltage	Input-output, test time 1 minute, leakage current less than 1mA	1500	--	--	VDC
Insulation Resistance	Input-output, insulated voltage 500VDC	1000	--	--	MΩ
Isolation Capacitance	Input-output, 100KHz/0.1V	--	120	--	pF
Operating Temperature	Derating when operating temperature ≥ 85°C, (See Figure 1)	-40	--	85	°C
Storage Temperature		-55	--	105	
Storage Humidity	Non-condensing	--	--	95	%RH
Pin welding can withstand the highest temperature	Soldering spot is 1.5mm away from case for 10 seconds	--	--	300	°C
Switching Frequency	Full load, nominal input voltage	150	208	300	kHz
MTBF	MIL-HDBK-217F@25°C	>1000Kh			

Mechanical Specifications

Case Material	Black plastic; flame-retardant and heat-resistant (UL94V-0)
Package Dimensions	22.00 * 12.00 * 9.50 mm
Weight	3.8g(Typ.)
Cooling Method	Free air convection

EMC Specifications

EMI	CE	CISPR32/EN55032 CLASS B (The recommended circuit is shown in Figure 3-②)
	RE	CISPR32/EN55032 CLASS B (The recommended circuit is shown in Figure 3-②)
EMS	ESD	IEC/EN61000-4-2 Contact±4KV perf.Criteria B
	RS	IEC/EN61000-4-3 10V/m Perf.Criteria A
	EFT	IEC/EN61000-4-4 ±2KV (The recommended circuit is shown in Figure 3-①) Perf.Criteria B
	Surge	IEC/EN61000-4-5 line to line±2KV (The recommended circuit is shown in Figure 3-①) Perf.Criteria B
	Cs	IEC/EN61000-4-6 3 Vr.m.s Perf.Criteria A

Typical Characteristic Curves

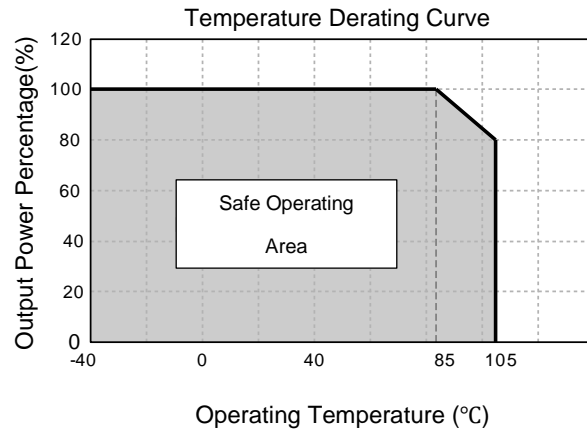
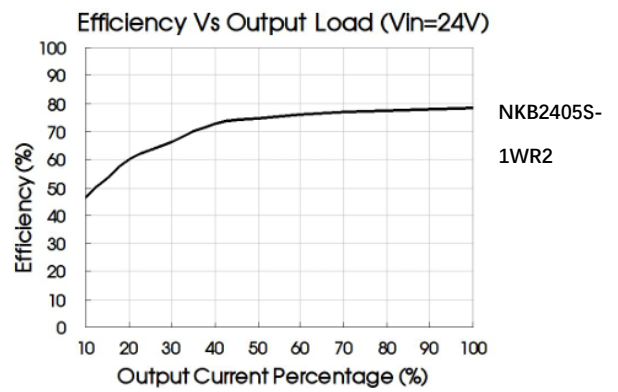
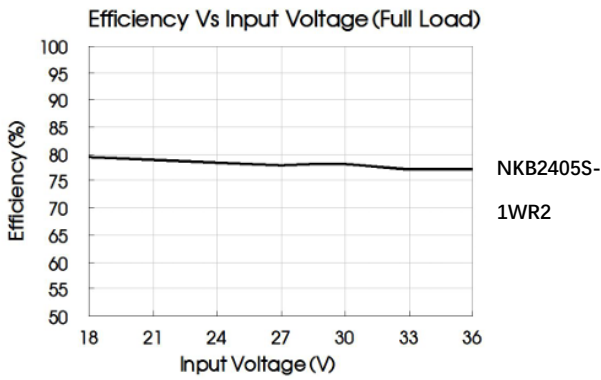
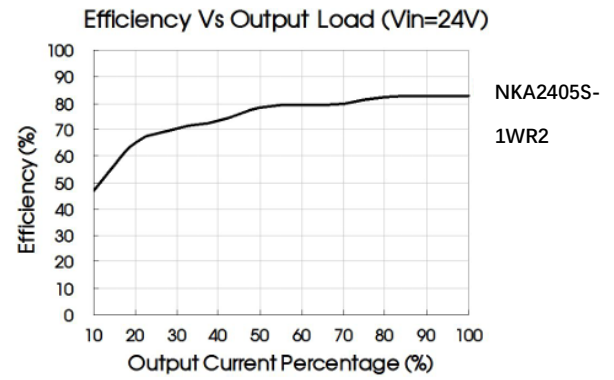
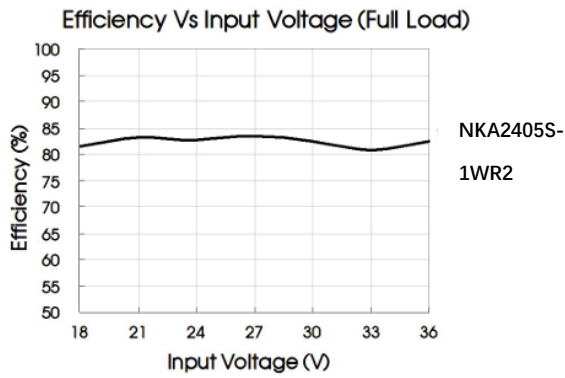
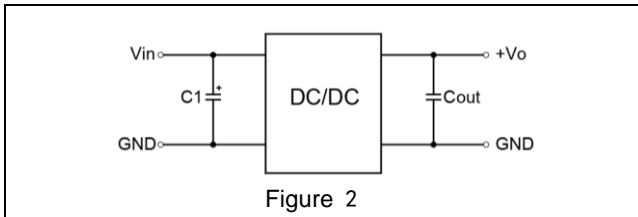

Figure 1



Circuit Design and Application



Recommended Capacitive Load Value Table	
Cin(μ F)	Cout(μ F)
100	10

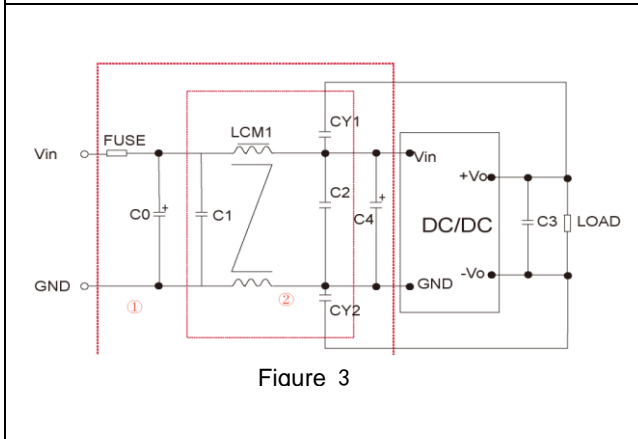

EMI Recommended Parameter Table		
Model	Vin:12V	Vin:24V
FUSE	Select according to the actual input current of the customer	
C0、C4	330uF/35V	330uF/50V
C1、C2	10 μ F/50V	
LCM1	1.4-1.7mH	
C3	22 μ F/50V	
CY1、CY2	1nF/400VAC	

Note: Part 1 in Figure 3 is for EMC testing; The second part is used for EMI filtering, which can be selected according to the demand.

Dimensions and Recommended Layout

Dimensions

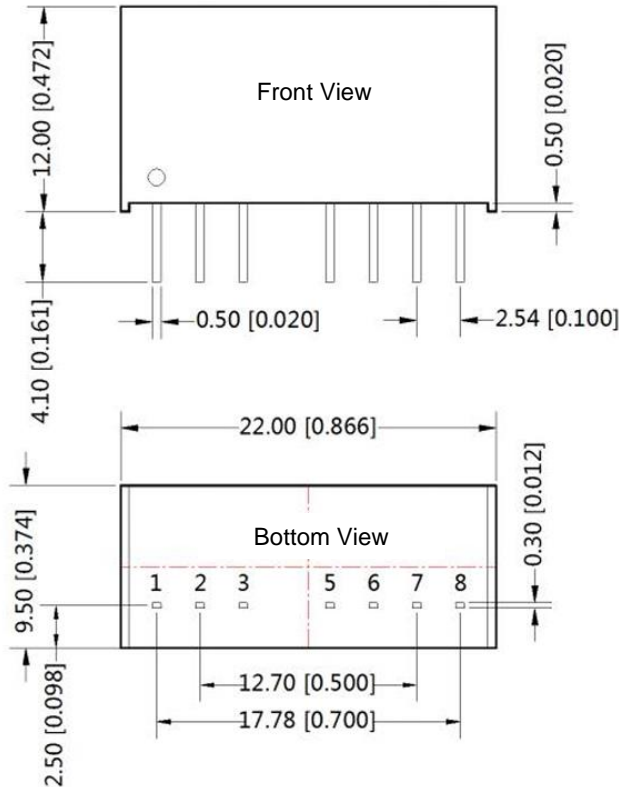

PCB Printing Layout & Pin Definition Table

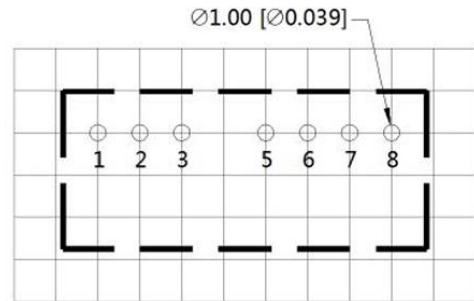

Note: The grid distance is 2.54mm*2.54mm

Pin	Function (single)	Function (double)
1	GND	GND
2	Vin	Vin
3	CTRL	CTRL
5	NC	NC
6	+Vo	+Vo
7	0V	0V
8	CS	-Vo

NC: Cannot be connected to any electrical connection

Note:

Unit: mm[inch]

Pin section tolerances: ± 0.10 [± 0.004]

General tolerances: ± 0.50 [± 0.020]

Note:

1. If the product works under the minimum required load, it cannot guarantee that the performance of the product complies with all the performance indicators in this manual;
2. The maximum capacitive load is tested under the input voltage range and full load condition;
3. Unless otherwise stated, all indexes in this manual are measured at $T_a=25^\circ\text{C}$, humidity $<75\%RH$, nominal input voltage and rated output load;
4. All index testing methods in this manual are based on the enterprise standards of the company;
5. Our company can provide product customization, specific needs can directly contact our technical staff;

NORPAS-POWER TECHNOLOGY CO., LTD.

www.norpas-power.com Mail: info@norpas-power.com

Specifications can be changed without notice! Make sure you are using the latest documentation, downloadable at www.norpas-power.com

REV:07/2024