



# Product Specification

G170EG01 V1

AU OPTRONICS CORPORATION

Preliminary Specification

Final Specification

|                   |                          |
|-------------------|--------------------------|
| <b>Module</b>     | 17.0" SXGA Color TFT-LCD |
| <b>Model Name</b> | G170EG01 V1              |

|   |             |
|---|-------------|
| <b>Customer</b>   | <b>Date</b> |
| _____   | _____       |
| <b>Approved by</b>  |             |
| Note: This Specification is subject to change without notice. |             |

|  |             |
|--|-------------|
| <b>Checked &amp; Approved by</b>                             | <b>Date</b> |
| <i>Vito Huang</i>  | 2011/09/30  |
| <b>Prepared by</b>   |             |
| <i>Jimmy Tsai</i>  | 2011/09/30  |
| Desktop Display Business Group /<br>AU Optronics corporation |             |

AUO Confidential For PROMOTE Internal Use Only 2011/11/23

## Contents

|  |           |
|--|-----------|
| <b>1. Handling Precautions .....</b>                           | <b>4</b>  |
| <b>2. General Description .....</b>                            | <b>5</b>  |
| 2.1 Display Characteristics .....                              | 5         |
| 2.2 Optical Characteristics .....                              | 6         |
| <b>3. Functional Block Diagram.....</b>                        | <b>10</b> |
| <b>4. Absolute Maximum Ratings.....</b>                        | <b>11</b> |
| 4.1 TFT LCD Module .....                                       | 11        |
| 4.2 Backlight Unit .....                                       | 11        |
| 4.3 Absolute Ratings of Environment .....                      | 11        |
| <b>5. Electrical characteristics .....</b>                     | <b>12</b> |
| 5.1 TFT LCD Module .....                                       | 12        |
| 5.2 Backlight Unit .....                                       | 14        |
| <b>6. Signal Characteristic .....</b>                          | <b>15</b> |
| 6.1 Pixel Format Image .....                                   | 15        |
| 6.2 The Input Data Format .....                                | 15        |
| 6.3 Signal Description .....                                   | 16        |
| 6.4 Timing Characteristics .....                               | 18        |
| 6.5 Power ON/OFF Sequence .....                                | 20        |
| <b>7. Connector &amp; Pin Assignment .....</b>                 | <b>22</b> |
| 7.1 TFT LCD Module .....                                       | 22        |
| 7.2 Backlight Unit .....                                       | 23        |
| <b>8. Reliability Test .....</b>                               | <b>24</b> |
| <b>9. Label and Packaging .....</b>                            | <b>25</b> |
| 9.1 Shipping Label (on the rear side of TFT-LCD display) ..... | 25        |
| 9.2 Carton Package .....                                       | 25        |
| <b>10. Mechanical Characteristics .....</b>                    | <b>26</b> |

AUO Confidential For PROMATE Internal Use Only / 2011/11/23

## Record of Revision

| Version and Date                | Page   | Old description  | New Description  | Remark             |  |                           |  |                    |                    |   |                           |                      |       |            |             |                      |       |       |          |                     |   |                    |       |                     |       |       |       |      |        |      |      |      |            |                     |                |   |     |      |   |  |
|---------------------------------|--|--|--|--------------------|--|---------------------------|--|--------------------|--------------------|---|---------------------------|----------------------|-------|------------|-------------|----------------------|-------|-------|----------|---------------------|---|--------------------|-------|---------------------|-------|-------|-------|------|--------|------|------|------|------------|---------------------|----------------|---|-----|------|---|--|
| 0.1 2011/01/12                  | All  | First Edition for Customer   | All  |                    |  |                           |  |                    |                    |   |                           |                      |       |            |             |                      |       |       |          |                     |   |                    |       |                     |       |       |       |      |        |      |      |      |            |                     |                |   |     |      |   |  |
| 0.2 2011/01/14                  | 5  | 350 (center, Typ)@7.5 mA   | 350  |                    |  |                           |  |                    |                    |   |                           |                      |       |            |             |                      |       |       |          |                     |   |                    |       |                     |       |       |       |      |        |      |      |      |            |                     |                |   |     |      |   |  |
|                                 | 24   | <table border="1"> <thead> <tr> <th>Items</th> <th>Required Condition</th> </tr> </thead> <tbody> <tr> <td>Temperature Humidity Bias (THB)</td> <td>Ta= 50°C, 90%RH, 300hours</td> </tr> </tbody> </table>   | Items  | Required Condition | Temperature Humidity Bias (THB)                              | Ta= 50°C, 90%RH, 300hours | <table border="1"> <thead> <tr> <th>Items</th> <th>Required Condition</th> </tr> </thead> <tbody> <tr> <td>Temperature Humidity Bias (THB)</td> <td>Ta= 50°C, 80%RH, 300hours</td> </tr> </tbody> </table> | Items              | Required Condition | Temperature Humidity Bias (THB)   | Ta= 50°C, 80%RH, 300hours |                      |       |            |             |                      |       |       |          |                     |   |                    |       |                     |       |       |       |      |        |      |      |      |            |                     |                |   |     |      |   |  |
| Items                           | Required Condition   |  |  |                    |  |                           |  |                    |                    |   |                           |                      |       |            |             |                      |       |       |          |                     |   |                    |       |                     |       |       |       |      |        |      |      |      |            |                     |                |   |     |      |   |  |
| Temperature Humidity Bias (THB) | Ta= 50°C, 90%RH, 300hours                                    |  |  |                    |  |                           |  |                    |                    |   |                           |                      |       |            |             |                      |       |       |          |                     |   |                    |       |                     |       |       |       |      |        |      |      |      |            |                     |                |   |     |      |   |  |
| Items                           | Required Condition   |  |  |                    |  |                           |  |                    |                    |   |                           |                      |       |            |             |                      |       |       |          |                     |   |                    |       |                     |       |       |       |      |        |      |      |      |            |                     |                |   |     |      |   |  |
| Temperature Humidity Bias (THB) | Ta= 50°C, 80%RH, 300hours                                    |  |  |                    |  |                           |  |                    |                    |   |                           |                      |       |            |             |                      |       |       |          |                     |   |                    |       |                     |       |       |       |      |        |      |      |      |            |                     |                |   |     |      |   |  |
| 0.3 2011/01/24                  | 11   |  |  |                    |  |                           |  |                    |                    |   |                           |                      |       |            |             |                      |       |       |          |                     |   |                    |       |                     |       |       |       |      |        |      |      |      |            |                     |                |   |     |      |   |  |
|                                 | 26   | Thickness= 15.8 mm   | Thickness= 18.0 mm   |                    |  |                           |  |                    |                    |   |                           |                      |       |            |             |                      |       |       |          |                     |   |                    |       |                     |       |       |       |      |        |      |      |      |            |                     |                |   |     |      |   |  |
| 0.4 2011/04/06                  | 5, 6   | Optical ResponseTime= 5 ms   | Optical ResponseTime= 30 ms  |                    |  |                           |  |                    |                    |   |                           |                      |       |            |             |                      |       |       |          |                     |   |                    |       |                     |       |       |       |      |        |      |      |      |            |                     |                |   |     |      |   |  |
|                                 | 5  | This module does not contain an inverter card for backlight.   | This module embeds an LED driver on it.  |                    |  |                           |  |                    |                    |   |                           |                      |       |            |             |                      |       |       |          |                     |   |                    |       |                     |       |       |       |      |        |      |      |      |            |                     |                |   |     |      |   |  |
|                                 | 5  | Weight: 1800 (g) Typ.  | Weight: 1350 (g) Typ.  |                    |  |                           |  |                    |                    |   |                           |                      |       |            |             |                      |       |       |          |                     |   |                    |       |                     |       |       |       |      |        |      |      |      |            |                     |                |   |     |      |   |  |
|                                 | 11   | <table border="1"> <thead> <tr> <th colspan="6">4.2 Backlight Unit</th> </tr> <tr> <th>Item</th> <th>Symbol</th> <th>Min.</th> <th>Max.</th> <th>Unit</th> <th>Conditions</th> </tr> </thead> <tbody> <tr> <td>LED Current</td> <td>ICFL</td> <td>-</td> <td>110</td> <td>(mA) rms</td> <td>Note 1, 2</td> </tr> </tbody> </table> | 4.2 Backlight Unit   |                    |  |                           |  |                    | Item               | Symbol  | Min.                      | Max.                 | Unit  | Conditions | LED Current | ICFL                 | -     | 110   | (mA) rms | Note 1, 2           | <table border="1"> <thead> <tr> <th colspan="6">4.2 Backlight Unit</th> </tr> <tr> <th>Item</th> <th>Symbol</th> <th>Min.</th> <th>Max.</th> <th>Unit</th> <th>Conditions</th> </tr> </thead> <tbody> <tr> <td>LED Forward Current</td> <td>I<sub>f</sub></td> <td>-</td> <td>120</td> <td>(mA)</td> <td>-</td> </tr> </tbody> </table> | 4.2 Backlight Unit |       |                     |       |       |       | Item | Symbol | Min. | Max. | Unit | Conditions | LED Forward Current | I <sub>f</sub> | - | 120 | (mA) | - |  |
| 4.2 Backlight Unit              |  |  |  |                    |  |                           |  |                    |                    |   |                           |                      |       |            |             |                      |       |       |          |                     |   |                    |       |                     |       |       |       |      |        |      |      |      |            |                     |                |   |     |      |   |  |
| Item                            | Symbol   | Min.   | Max.   | Unit               | Conditions   |                           |  |                    |                    |   |                           |                      |       |            |             |                      |       |       |          |                     |   |                    |       |                     |       |       |       |      |        |      |      |      |            |                     |                |   |     |      |   |  |
| LED Current                     | ICFL   | -  | 110  | (mA) rms           | Note 1, 2  |                           |  |                    |                    |   |                           |                      |       |            |             |                      |       |       |          |                     |   |                    |       |                     |       |       |       |      |        |      |      |      |            |                     |                |   |     |      |   |  |
| 4.2 Backlight Unit              |  |  |  |                    |  |                           |  |                    |                    |   |                           |                      |       |            |             |                      |       |       |          |                     |   |                    |       |                     |       |       |       |      |        |      |      |      |            |                     |                |   |     |      |   |  |
| Item                            | Symbol   | Min.   | Max.   | Unit               | Conditions   |                           |  |                    |                    |   |                           |                      |       |            |             |                      |       |       |          |                     |   |                    |       |                     |       |       |       |      |        |      |      |      |            |                     |                |   |     |      |   |  |
| LED Forward Current             | I <sub>f</sub>   | -  | 120  | (mA)               | -  |                           |  |                    |                    |   |                           |                      |       |            |             |                      |       |       |          |                     |   |                    |       |                     |       |       |       |      |        |      |      |      |            |                     |                |   |     |      |   |  |
|                                 | 23   | No pins drawing of LED driver board  | New add pins drawing   |                    |  |                           |  |                    |                    |   |                           |                      |       |            |             |                      |       |       |          |                     |   |                    |       |                     |       |       |       |      |        |      |      |      |            |                     |                |   |     |      |   |  |
| 1.0 2011/09/30                  | 6  | Without RGB color coordinate   | <table border="1"> <tbody> <tr> <td>Red x<sup>o</sup></td> <td>0.598</td> <td>0.648</td> <td>0.698</td> </tr> <tr> <td>Red y<sup>o</sup></td> <td>0.289</td> <td>0.339</td> <td>0.389</td> </tr> <tr> <td>Green x<sup>o</sup></td> <td>0.273</td> <td>0.323</td> <td>0.373</td> </tr> <tr> <td>Green y<sup>o</sup></td> <td>0.563</td> <td>0.613</td> <td>0.663</td> </tr> <tr> <td>Blue x<sup>o</sup></td> <td>0.093</td> <td>0.143</td> <td>0.193</td> </tr> <tr> <td>Blue y<sup>o</sup></td> <td>0.020</td> <td>0.070</td> <td>0.120</td> </tr> </tbody> </table> | Red x <sup>o</sup> | 0.598  | 0.648                     | 0.698  | Red y <sup>o</sup> | 0.289              | 0.339   | 0.389                     | Green x <sup>o</sup> | 0.273 | 0.323      | 0.373       | Green y <sup>o</sup> | 0.563 | 0.613 | 0.663    | Blue x <sup>o</sup> | 0.093   | 0.143              | 0.193 | Blue y <sup>o</sup> | 0.020 | 0.070 | 0.120 |      |        |      |      |      |            |                     |                |   |     |      |   |  |
| Red x <sup>o</sup>              | 0.598  | 0.648  | 0.698  |                    |  |                           |  |                    |                    |   |                           |                      |       |            |             |                      |       |       |          |                     |   |                    |       |                     |       |       |       |      |        |      |      |      |            |                     |                |   |     |      |   |  |
| Red y <sup>o</sup>              | 0.289  | 0.339  | 0.389  |                    |  |                           |  |                    |                    |   |                           |                      |       |            |             |                      |       |       |          |                     |   |                    |       |                     |       |       |       |      |        |      |      |      |            |                     |                |   |     |      |   |  |
| Green x <sup>o</sup>            | 0.273  | 0.323  | 0.373  |                    |  |                           |  |                    |                    |   |                           |                      |       |            |             |                      |       |       |          |                     |   |                    |       |                     |       |       |       |      |        |      |      |      |            |                     |                |   |     |      |   |  |
| Green y <sup>o</sup>            | 0.563  | 0.613  | 0.663  |                    |  |                           |  |                    |                    |   |                           |                      |       |            |             |                      |       |       |          |                     |   |                    |       |                     |       |       |       |      |        |      |      |      |            |                     |                |   |     |      |   |  |
| Blue x <sup>o</sup>             | 0.093  | 0.143  | 0.193  |                    |  |                           |  |                    |                    |   |                           |                      |       |            |             |                      |       |       |          |                     |   |                    |       |                     |       |       |       |      |        |      |      |      |            |                     |                |   |     |      |   |  |
| Blue y <sup>o</sup>             | 0.020  | 0.070  | 0.120  |                    |  |                           |  |                    |                    |   |                           |                      |       |            |             |                      |       |       |          |                     |   |                    |       |                     |       |       |       |      |        |      |      |      |            |                     |                |   |     |      |   |  |
|                                 | 6  | <table border="1"> <tbody> <tr> <td>Contrast Ratio</td> <td>-</td> <td>-</td> <td>600</td> <td>1000</td> <td>-</td> <td>4</td> </tr> </tbody> </table>   | Contrast Ratio   | -                  | -  | 600                       | 1000   | -                  | 4                  | <table border="1"> <tbody> <tr> <td>Contrast Ratio</td> <td>-</td> <td>-</td> <td>600</td> <td>800</td> <td>-</td> <td>4</td> </tr> </tbody> </table> | Contrast Ratio            | -                    | -     | 600        | 800         | -                    | 4     |       |          |                     |   |                    |       |                     |       |       |       |      |        |      |      |      |            |                     |                |   |     |      |   |  |
| Contrast Ratio                  | -  | -  | 600  | 1000               | -  | 4                         |  |                    |                    |   |                           |                      |       |            |             |                      |       |       |          |                     |   |                    |       |                     |       |       |       |      |        |      |      |      |            |                     |                |   |     |      |   |  |
| Contrast Ratio                  | -  | -  | 600  | 800                | -  | 4                         |  |                    |                    |   |                           |                      |       |            |             |                      |       |       |          |                     |   |                    |       |                     |       |       |       |      |        |      |      |      |            |                     |                |   |     |      |   |  |
|                                 | 24   | Without EMI item is RA list  | <table border="1"> <tbody> <tr> <td>EMI</td> <td>30-230 MHz, limit 40 dBu V/m, 230-1000 MHz, limit 47 dBu V/m</td> </tr> </tbody> </table>   | EMI                | 30-230 MHz, limit 40 dBu V/m, 230-1000 MHz, limit 47 dBu V/m |                           |  |                    |                    |   |                           |                      |       |            |             |                      |       |       |          |                     |   |                    |       |                     |       |       |       |      |        |      |      |      |            |                     |                |   |     |      |   |  |
| EMI                             | 30-230 MHz, limit 40 dBu V/m, 230-1000 MHz, limit 47 dBu V/m |  |  |                    |  |                           |  |                    |                    |   |                           |                      |       |            |             |                      |       |       |          |                     |   |                    |       |                     |       |       |       |      |        |      |      |      |            |                     |                |   |     |      |   |  |
|                                 | 25   | Outside dimension of carton:434(L)mm*278(W)mm*390(H)mm   | Outside dimension of carton:426(L)mm*270(W)mm*375(H)mm   |                    |  |                           |  |                    |                    |   |                           |                      |       |            |             |                      |       |       |          |                     |   |                    |       |                     |       |       |       |      |        |      |      |      |            |                     |                |   |     |      |   |  |

## 1. Handling Precautions

- 1) Since front polarizer is easily damaged, pay attention not to scratch it.
- 2) Be sure to turn off power supply when inserting or disconnecting from input connector.
- 3) Wipe off water drop immediately. Long contact with water may cause discoloration or spots.
- 4) When the panel surface is soiled, wipe it with absorbent cotton or other soft cloth.
- 5) Since the panel is made of glass, it may break or crack if dropped or bumped on hard surface.
- 6) Since CMOS LSI is used in this module, take care of static electricity and insure human earth when handling.
- 7) Do not open or modify the Module Assembly.
- 8) Do not press the reflector sheet at the back of the module to any directions.
- 9) In case if a Module has to be put back into the packing container slot after once it was taken out from the container, do not press the center of the LED light bar edge. Instead, press at the far ends of the LED light bar edge softly. Otherwise the TFT Module may be damaged.
- 10) At the insertion or removal of the Signal Interface Connector, be sure not to rotate nor tilt the Interface Connector of the TFT Module.
- 11) After installation of the TFT Module into an enclosure, do not twist nor bend the TFT Module even momentary. At designing the enclosure, it should be taken into consideration that no bending/twisting forces are applied to the TFT Module from outside. Otherwise the TFT Module may be damaged.
- 12) Small amount of materials having no flammability grade is used in the LCD module. The LCD module should be supplied by power complied with requirements of Limited Power Source (IEC60950 or UL1950), or be applied exemption.

AUO Confidential For PROMATE Internal Use Only / 2017/1/23

## 2. General Description

This specification applies to the 17 inch Color TFT-LCD Module G170EG01 V1.

The display supports the SXGA+ (1280(H) x 1024(V)) screen format and 16.7M colors (RGB 6-bits+Hi-FRC data). All input signals are 2 Channel LVDS interface compatible.

This module embeds an LED driver on it.

### 2.1 Display Characteristics

The following items are characteristics summary on the table under 25 °C condition:

| Items                                      | Unit                 | Specifications                                      |
|--|----------------------|---|
| Screen Diagonal                            | [mm]                 | 432 (17.0")   |
| Active Area                                | [mm]                 | 337.920(H) × 270.336(V)                             |
| Pixels H x V                               |                      | 1280 × 3(RGB) × 1024                                |
| Pixel Pitch                                | [mm]                 | 0.264(per one triad) × 0.264                        |
| Pixel Arrangement                          |                      | R.G.B. Vertical Stripe                              |
| Display Mode                               |                      | Normally White                                      |
| White Luminance                            | [cd/m <sup>2</sup> ] | 350   |
| Contrast Ratio                             |                      | 800 : 1 (Typ)                                       |
| Optical ResponseTime                       | [msec]               | 30 (Typ)  |
| Nominal Input Voltage VDD                  | [Volt]               | +5.0 (Typ)  |
| Power Consumption<br>(VDD line + LED line) | [Watt]               | 22 W (Typ.)<br>(with LED driver, all black pattern) |
| Weight                                     | [Grams]              | 1350 Typ.   |
| Physical Size (H x V x D)                  | [mm]                 | 358.5(H) x 296.5(V) Typ. x 18.0(D) Max              |
| Electrical Interface                       |                      | Dual Channel LVDS                                   |
| Surface Treatment                          |                      | Anti-glare type, Hardness 3H                        |
| Support Color                              |                      | 16.7M colors (RGB 6-bits +Hi-FRC data)              |
| Temperature Range<br>Operating             | [°C]                 | -30 to +85  |
| Storage (Non-Operating)                    | [°C]                 | -30 to +85  |
| RoHS Compliance                            |                      | RoHS Compliance                                     |

## 2.2 Optical Characteristics

The optical characteristics are measured under stable conditions at 25°C (Room Temperature):

| Item  | Unit                 | Conditions                           | Min.     | Typ.     | Max.  | Note |
|---|----------------------|--------------------------------------|----------|----------|-------|------|
| Viewing Angle                               | [degree]             | Horizontal (Right)<br>CR = 10 (Left) | 70<br>70 | 85<br>85 | -     | 1    |
|   |                      | Vertical (Up)<br>CR = 10 (Down)      | 70<br>70 | 80<br>80 | -     |      |
|   |                      | Horizon (Right)<br>CR = 5 (Left)     | 75<br>75 | 85<br>85 | -     |      |
|   |                      | Vertical (Up)<br>CR = 5 (Down)       | 75<br>75 | 85<br>85 | -     |      |
| Luminance Uniformity                        | [%]                  | 9 Points                             | 75       | 80       | -     | 2, 3 |
| Optical Response Time                       | [msec]               | Rising                               | -        | 20       | 25    | 4, 6 |
|   |                      | Falling                              | -        | 10       | 15    |      |
|   |                      | Rising + Falling                     | -        | 30       | 40    |      |
| Color / Chromaticity Coordinates (CIE 1931) |                      | Red x                                | 0.598    | 0.648    | 0.698 | 4    |
|   |                      | Red y                                | 0.289    | 0.339    | 0.389 |      |
|   |                      | Green x                              | 0.273    | 0.323    | 0.373 |      |
|   |                      | Green y                              | 0.563    | 0.613    | 0.663 |      |
|   |                      | Blue x                               | 0.093    | 0.143    | 0.193 |      |
|   |                      | Blue y                               | 0.020    | 0.070    | 0.120 |      |
|   |                      | White x                              | 0.263    | 0.313    | 0.363 |      |
| White y                                     | 0.279                | 0.329                                | 0.379    |          |       |      |
| White Luminance (At LED= 110mA)             | [cd/m <sup>2</sup> ] |                                      | 280      | 350      | -     | 4    |
| Contrast Ratio                              |                      |                                      | 600      | 800      | -     | 4    |
| Cross Talk (At 75Hz)                        | [%]                  |                                      | -        | -        | 1.5   | 5    |
| Flicker                                     | [dB]                 |                                      | -        | -        | -20   | 7    |

Optical Equipment: BM-5A, BM-7, PR880, or equivalent

**Note 1: Definition of viewing angle**

Viewing angle is the measurement of contrast ratio  $\geq 10$ , at the screen center, over a  $180^\circ$  horizontal and  $180^\circ$  vertical range (off-normal viewing angles). The  $180^\circ$  viewing angle range is broken down as follows;  $90^\circ$  ( $\theta$ ) horizontal left and right and  $90^\circ$  ( $\Phi$ ) vertical, high (up) and low (down). The measurement direction is typically perpendicular to the display surface with the screen rotated about its center to develop the desired measurement viewing angle.

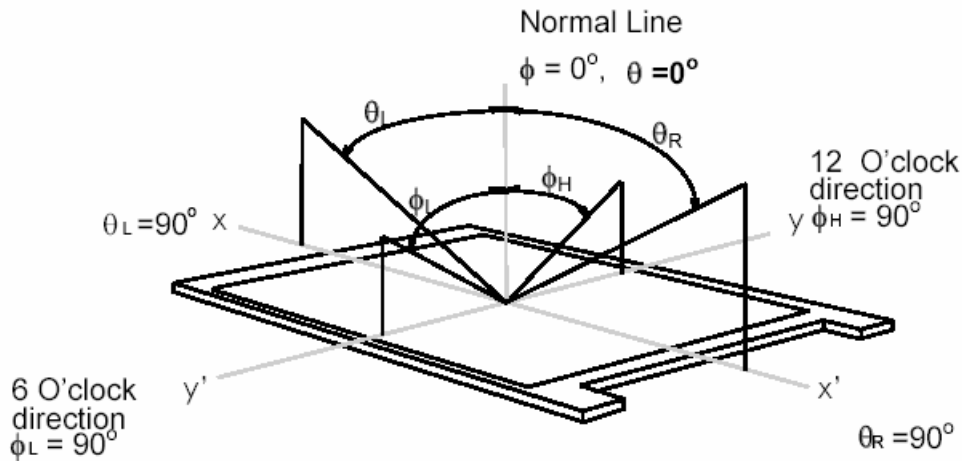

**Note 2: 9 points position**

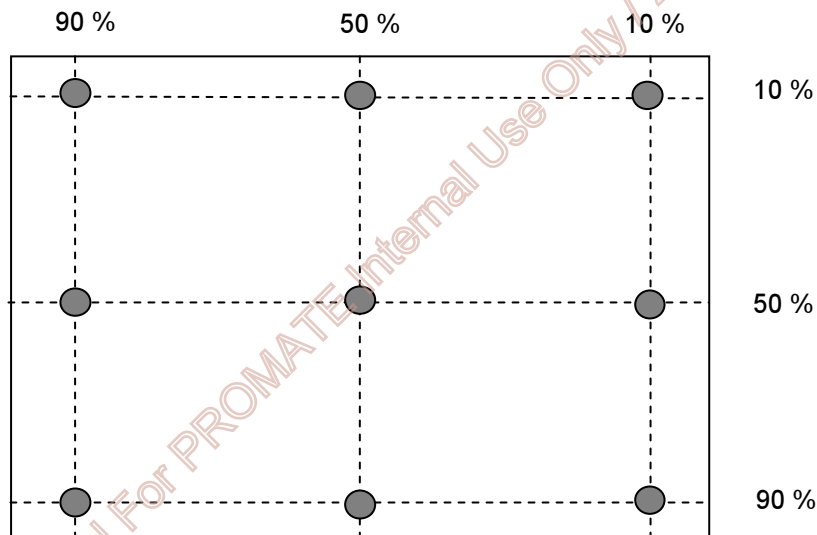

**Note 3: The luminance uniformity of 9 points is defined by dividing the maximum luminance values by the minimum test point luminance**

$$\delta_{w9} = \frac{\text{Minimum Luminance of 9 points}}{\text{Maximum Luminance of 9 points}}$$



**Note 4: Measurement method**

The LCD module should be stabilized at given temperature for 30 minutes to avoid abrupt temperature change during measuring. In order to stabilize the luminance, the measurement should be executed after lighting Backlight for 30 minutes in a stable, windless and dark room.

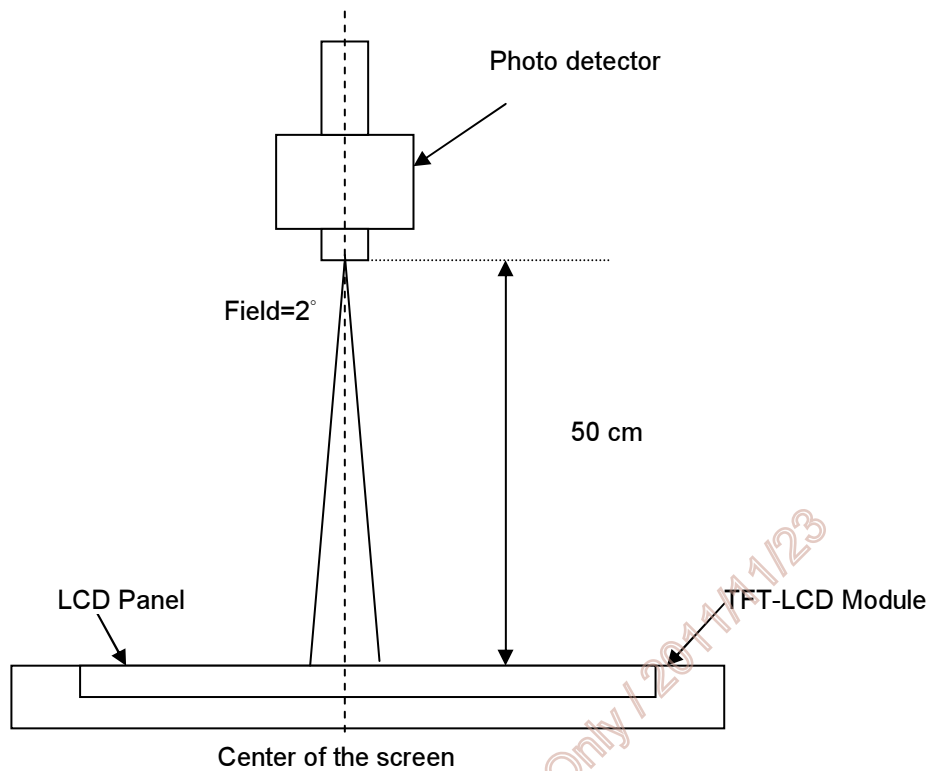

**Note 5: Definition of Cross Talk (CT)**

$$CT = | YB - YA | / YA \times 100 (\%)$$

Where

YA = Luminance of measured location without gray level 0 pattern (cd/m2)

YB = Luminance of measured location with gray level 0 pattern (cd/m2)

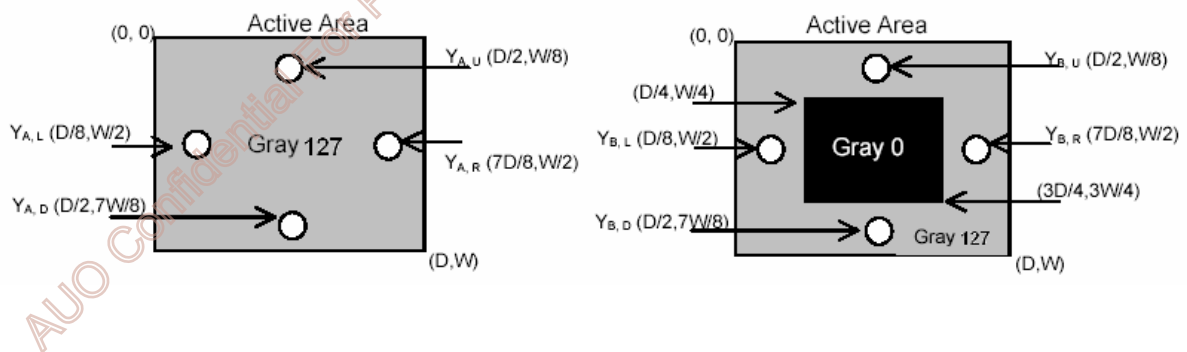



Note 6: Definition of response time:

The output signals of photo detector are measured when the input signals are changed from “Full Black” to “Full White” (rising time), and from “Full White” to “Full Black ”(falling time), respectively. The response time is interval between the 10% and 90% of amplitudes. Please refer to the figure as below.

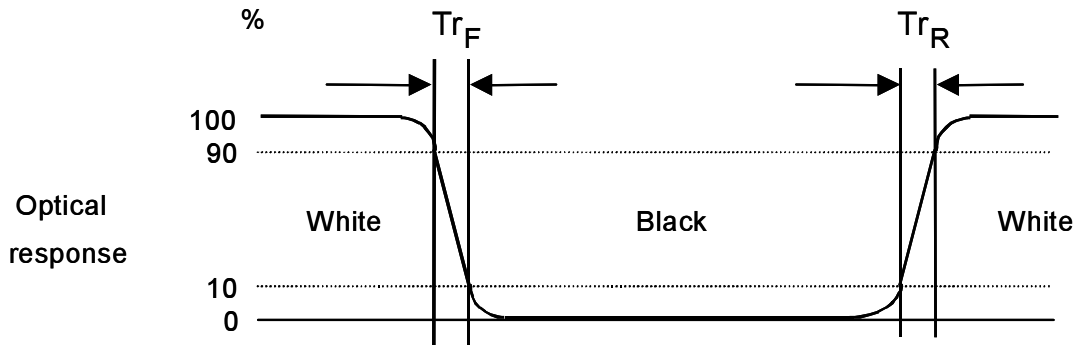

Note 7: Subchecker Pattern

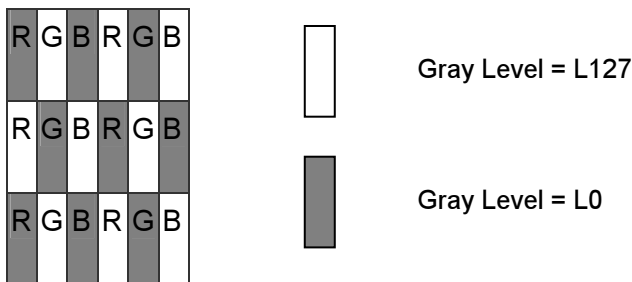

Method: Record dBV & DC value with (WESTAR) TRD-100

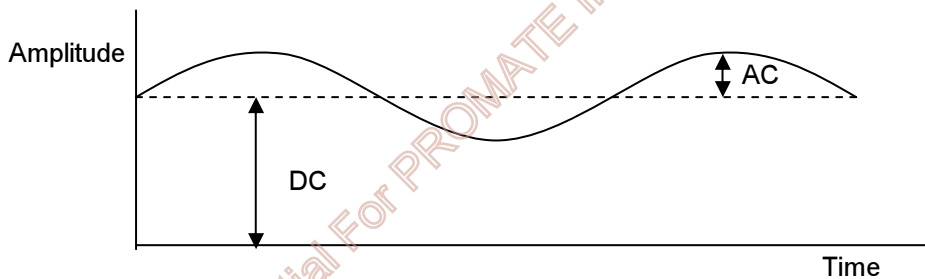

$$\text{Flicker (dB)} = 20 \log \frac{\text{AC Level(at 30 Hz)}}{\text{DC Level}}$$

### 3. Functional Block Diagram

The following diagram shows the functional block of the 17.0 inches Color TFT-LCD Module:

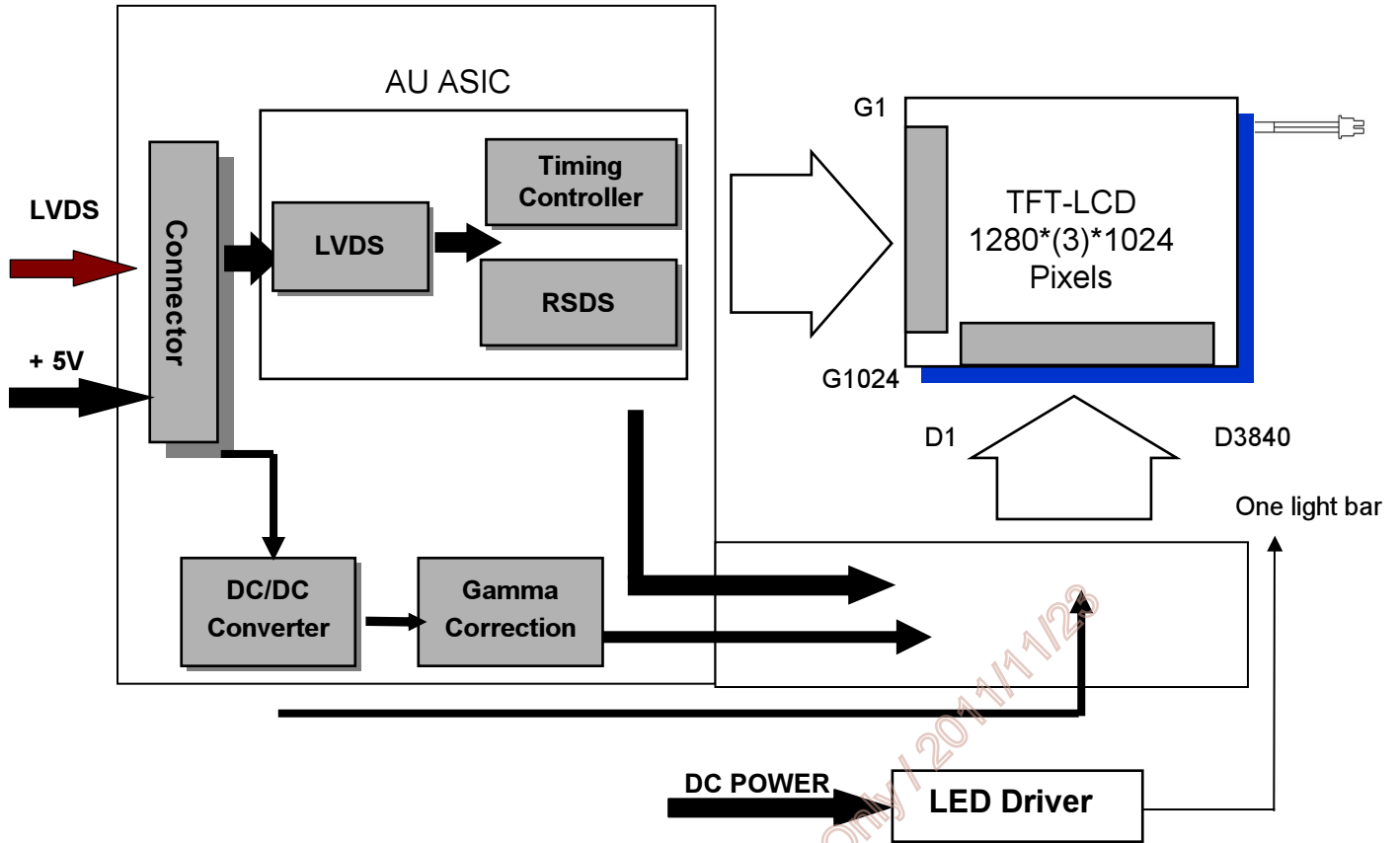

**PCBA Connector:**

JAE FI-XB30SSL-HF15  
Or Compatible

**LED Driver Connector:**

3806K-F06Y-03R  
Or Compatible

AUO Confidential For PROMATE Internal Use Only 1201171128

## 4. Absolute Maximum Ratings

Absolute maximum ratings of the module is as following:

### 4.1 TFT LCD Module

| Item                    | Symbol | Min  | Max | Unit   | Conditions      |
|-------------------------|--------|------|-----|--------|-----------------|
| Logic/LCD Drive Voltage | VIN    | -0.3 | 6   | [Volt] | <b>Note 1,2</b> |

### 4.2 Backlight Unit

| Item                | Symbol         | Min | Max | Unit | Conditions      |
|---------------------|----------------|-----|-----|------|-----------------|
| LED Forward Current | I <sub>F</sub> | -   | 120 | [mA] | <b>Note 1,2</b> |

### 4.3 Absolute Ratings of Environment

| Item                  | Symbol | Min | Max | Unit  | Conditions    |
|-----------------------|--------|-----|-----|-------|---------------|
| Operating Temperature | TOP    | -30 | +85 | [°C]  | <b>Note 3</b> |
| Operation Humidity    | HOP    | 8   | 90  | [%RH] |               |
| Storage Temperature   | TST    | -30 | +85 | [°C]  |               |
| Storage Humidity      | HST    | 8   | 90  | [%RH] |               |

**Note 1:** With in Ta (25°C )

**Note 2:** Permanent damage to the device may occur if exceed maximum values

**Note 3:** For quality performance, please refer to AUO IIS (Incoming Inspection Standard).

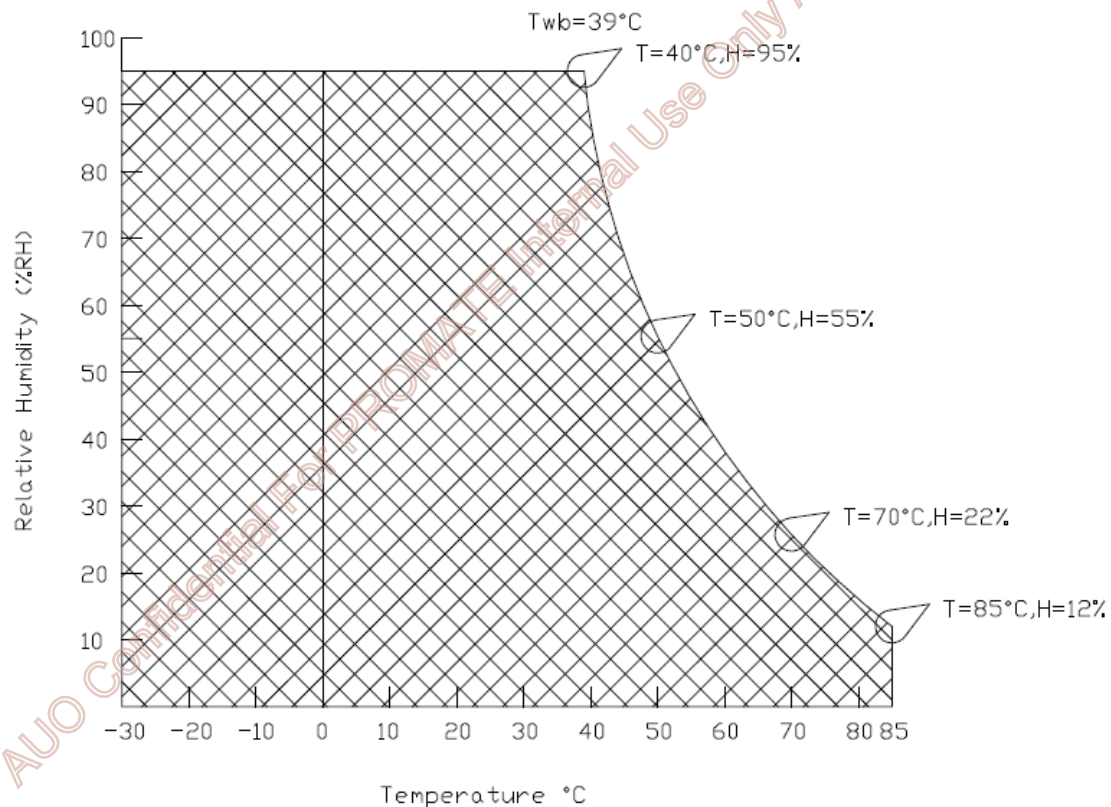

## 5. Electrical characteristics

### 5.1 TFT LCD Module

#### 5.1.1 Power Specification

Input power specifications are as follows:

| Symbol | Parameter                                | Min. | Typ. | Max. | Unit     | Condition  |
|--------|--|------|------|------|----------|--|
| VCC    | Logic/LCD Drive Voltage                  | 4.5  | 5.0  | 5.5  | [Volt]   | ±10%   |
| ICC    | Input Current                            | -    | 1.05 | 1.16 | [A]      | V <sub>in</sub> =5V , All Black Pattern, at 75Hz |
| IRush  | Inrush Current                           | -    | -    | 3.0  | [A]      | Note   |
| PCC    | VCC Power                                | -    | 5.25 | 5.8  | [Watt]   | V <sub>in</sub> =5V , All Black Pattern, at 75Hz |
| VCCrp  | Allowable Logic/LCD Drive Ripple Voltage | -    | -    | 200  | [mV] p-p | With panel loading                               |

Note: Measurement conditions:

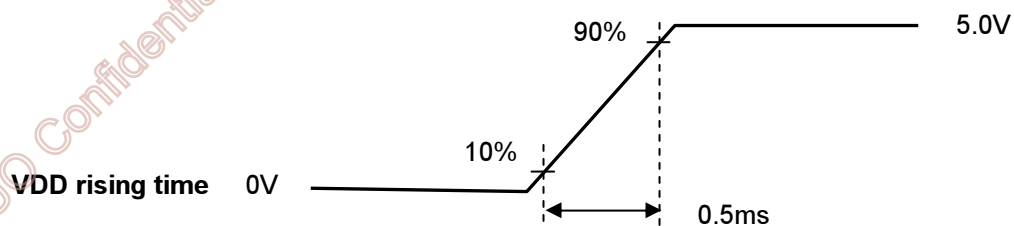
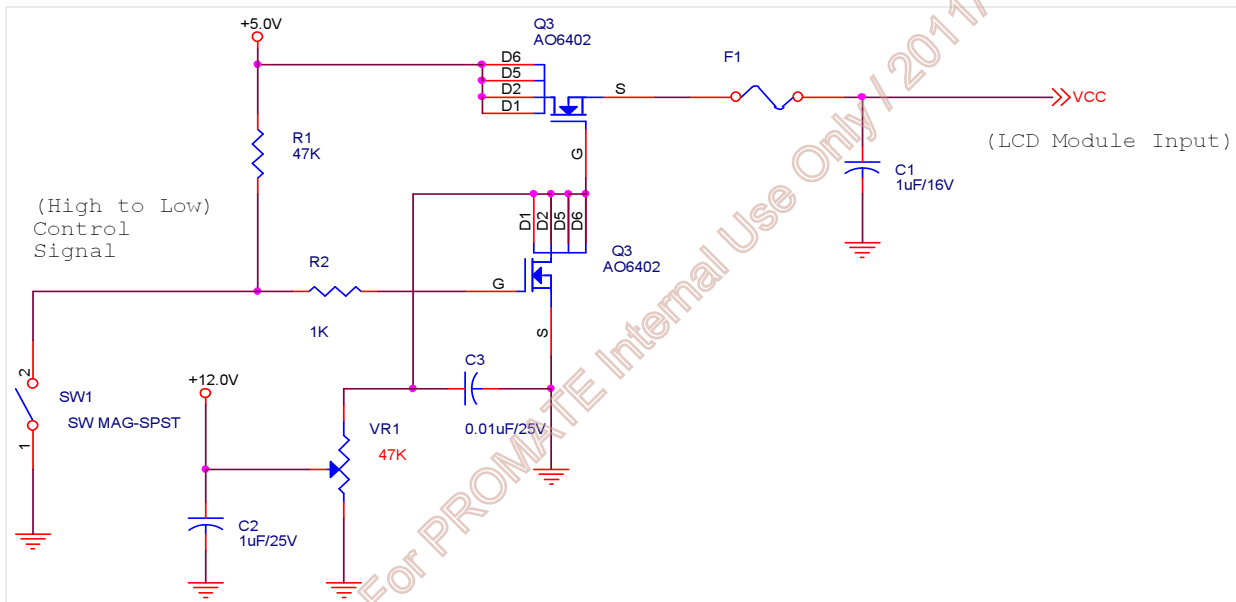

## 5.1.2 Signal Electrical Characteristics

Input signals shall be low or Hi-Z state when  $V_{in}$  is off

It is recommended to refer the specifications of SN75LVDS82DGG (Texas Instruments) in detail.

Each signal characteristics are as follows;

| Symbol | Parameter                              | Min  | Typ  | Max  | Units | Condition                                  |
|--------|--|------|------|------|-------|--|
| VTH    | Differential Input High Threshold      | -    | -    | +100 | [mV]  | $V_{ICM} = 1.2V$<br><b>Note</b>            |
| VTL    | Differential Input Low Threshold       | -100 | -    | -    | [mV]  | $V_{ICM} = 1.2V$<br><b>Note</b>            |
| VID    | Input Differential Voltage             | 100  | 400  | 600  | [mV]  | <b>Note</b>                                |
| VICM   | Differential Input Common Mode Voltage | +1.0 | +1.2 | +1.5 | [V]   | $V_{TH}/V_{TL} = \pm 100mV$<br><b>Note</b> |

**Note:** LVDS Signal Waveform

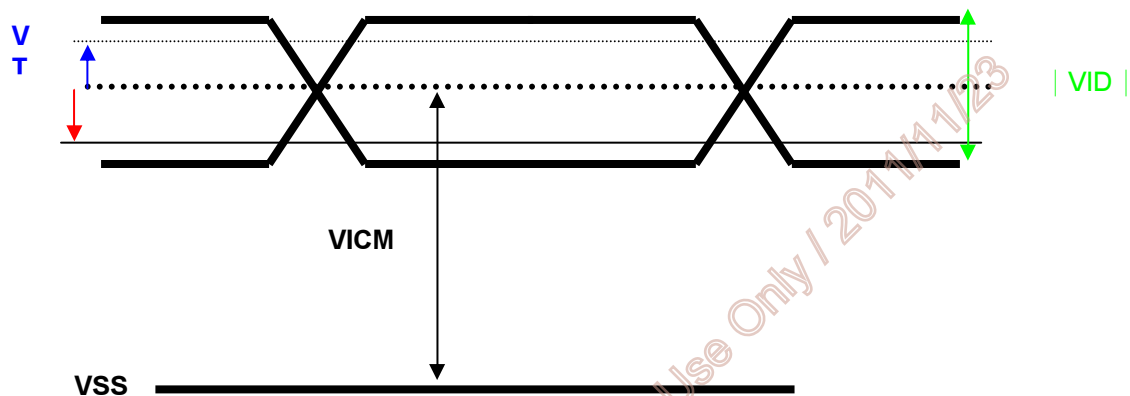

## 5.2 Backlight Unit

### Parameter guideline LED

Following characteristics are measured under stable condition at 25°C (Room Temperature)

| Symbol           | Parameter             | Min.  | Typ.  | Max. | Unit | Remark                        |
|------------------|-----------------------|-------|-------|------|------|-------------------------------|
| $V_{LED}$        | Input Voltage         | 10.8  | 12    | 12.6 | Volt |                               |
| $I_{LED}$        | Input Current         | -     | 1.18  | -    | A    | 100% Dimming                  |
| $P_{LED}$        | Power Consumption     | -     | 14.16 | -    | Watt | 100% Dimming                  |
| $I_{INRUSH LED}$ | Inrush Current        | -     | -     | 5.1  | A    | $V_{LED}$ rising time ~ 470us |
| $F_{PWM}$        | PWM Dimming Frequency | 200   | -     | 20K  | Hz   | Note 1,2                      |
| $V_{PWM DIM}$    | Swing Voltage High    | 4.5   | 5.0   | 5.5  | Volt |                               |
|                  | Swing Voltage Low     | -     | -     | 0.8  | Volt |                               |
| $D_{PWM}$        | Dimming Duty Cycle    | 10    | -     | 100  | %    |                               |
| $I_F$            | LED Forward Current   | -     | 110   | -    | mA   | Ta = 25°C                     |
| $V_{LED ON/OFF}$ | On Control Voltage    | 3.0   | 3.3   | 5.5  | Volt | Note 3, 4                     |
|                  | Off Control Voltage   | -     | -     | 0.8  | Volt |                               |
| Operating Life   |                       | 50000 | -     | -    | Hrs  | Note 5, 6                     |

Note 1: PWM dimming function can be operated by PWM signal. PWM duty cycle can adjust white Luminance.  
(PWM High: ON and PWM Low: OFF)

Note 2: PWM signal can not be floating and pull-down to ground when waiting.

Note 3: Enable ( $V_{LED On/Off}$ ) must be turned on late than  $V_{LED}$  and PWM Signal.

Note 4: Enable ( $V_{LED On/Off}$ ) must be turned off early than  $V_{LED}$  and PWM Signal.

Note 5: If G170EG01 V1 module is driven by high current or at high ambient temperature & humidity condition. The operating life will be reduced.

Note 6: Operating life means brightness goes down to 50% initial brightness. Minimum operating life time is estimated data.

## 6. Signal Characteristic

### 6.1 Pixel Format Image

Following figure shows the relationship of the input signals and LCD pixel format.

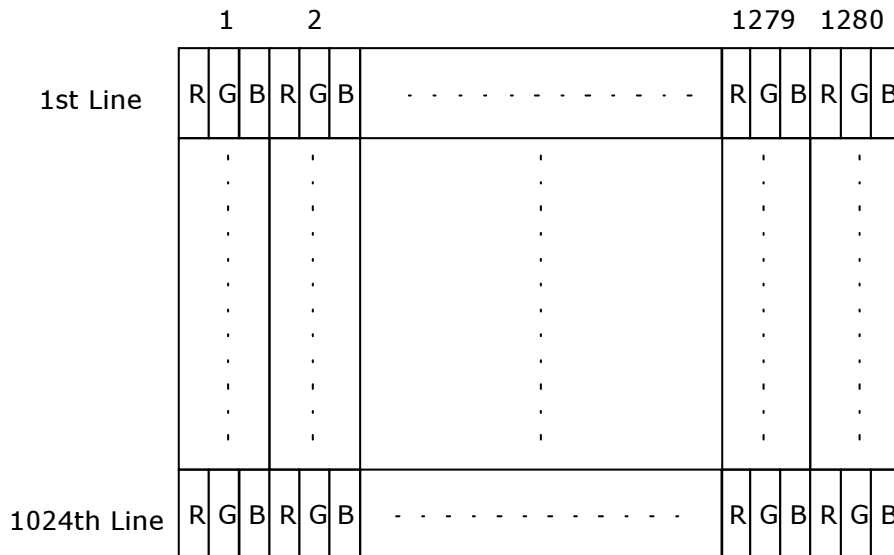

### 6.2 The Input Data Format

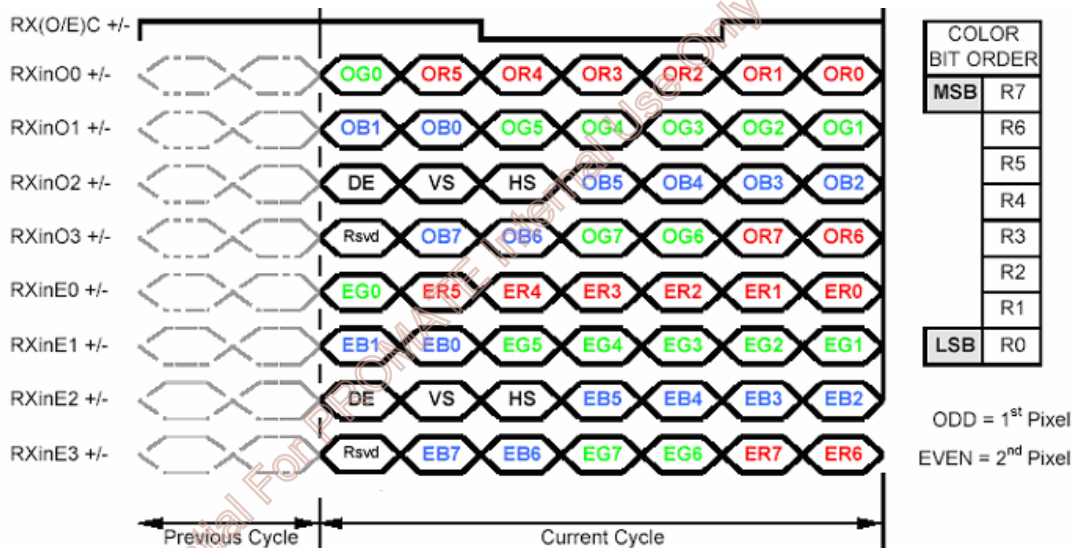

Note1: Normally, DE, VS, HS on EVEN channel are not used.

Note2: Please follow PSWG.

Note3: 8-bit in



## 6.3 Signal Description

The module using a pair of LVDS receiver SN75LVDS82(Texas Instruments) or compatible. LVDS is a differential signal technology for LCD interface and high speed data transfer device. Transmitter shall be SN75LVDS83(negative edge sampling) or compatible. The first LVDS port(RxOxxx) transmits odd pixels while the second LVDS port(RxExxx) transmits even pixels.

| PIN # | SIGNAL NAME | DESCRIPTION  |
|-------|-------------|--|
| 1     | RxO0-       | Negative LVDS differential data input (Odd data)                       |
| 2     | RxO0+       | Positive LVDS differential data input (Odd data)                       |
| 3     | RxO1-       | Negative LVDS differential data input (Odd data)                       |
| 4     | RxO1+       | Positive LVDS differential data input (Odd data)                       |
| 5     | RxO2-       | Negative LVDS differential data input (Odd data, H-Sync,V-Sync,DSPTMG) |
| 6     | RxO2+       | Positive LVDS differential data input (Odd data, H-Sync,V-Sync,DSPTMG) |
| 7     | GND         | Power Ground   |
| 8     | RxOC-       | Negative LVDS differential clock input (Odd clock)                     |
| 9     | RxOC+       | Positive LVDS differential clock input (Odd clock)                     |
| 10    | RxO3-       | Negative LVDS differential data input (Odd data)                       |
| 11    | RxO3+       | Positive LVDS differential data input (Odd data)                       |
| 12    | RxE0-       | Negative LVDS differential data input (Even data)                      |
| 13    | RxE0+       | Positive LVDS differential data input (Even data)                      |
| 14    | GND         | Power Ground   |
| 15    | RxE1-       | Negative LVDS differential data input (Even data)                      |
| 16    | RxE1+       | Positive LVDS differential data input (Even data)                      |
| 17    | GND         | Power Ground   |
| 18    | RxE2-       | Negative LVDS differential data input (Even data)                      |
| 19    | RxE2+       | Positive LVDS differential data input (Even data)                      |
| 20    | RxEC-       | Negative LVDS differential clock input (Even clock)                    |
| 21    | RxEC+       | Positive LVDS differential clock input (Even clock)                    |
| 22    | RxE3-       | Negative LVDS differential data input (Even data)                      |
| 23    | RxE3+       | Positive LVDS differential data input (Even data)                      |
| 24    | GND         | Power Ground   |
| 25    | GND         | Power Ground (For AUO test Aging+HVS mode )                            |
| 26    | NC          | No contact   |
| 27    | GND         | Power Ground   |
| 28    | VCC         | +5.0V Power Supply   |
| 29    | VCC         | +5.0V Power Supply   |
| 30    | VCC         | +5.0V Power Supply   |

Note1: Start from left side

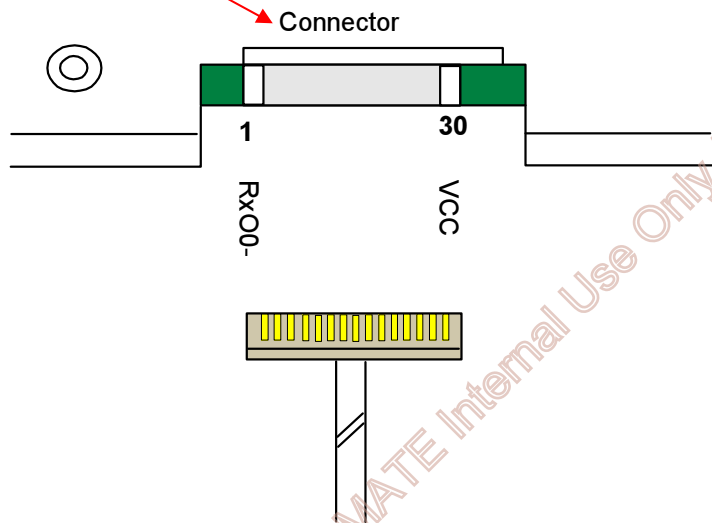
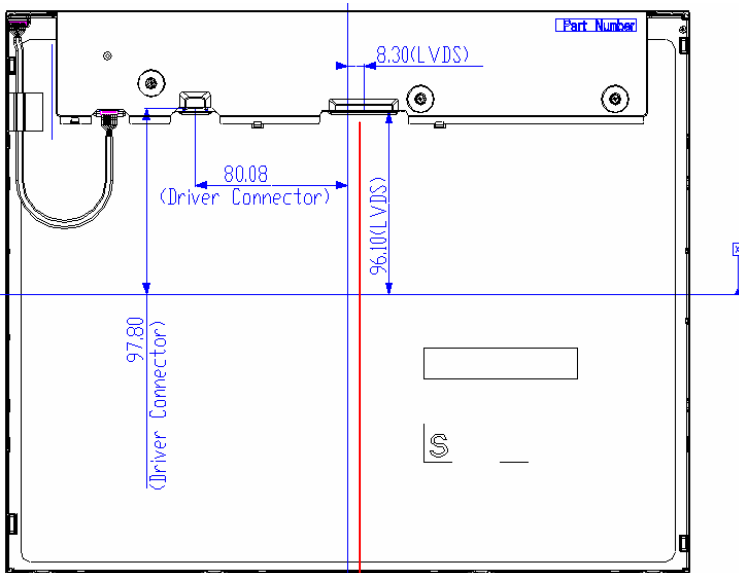

Note2: Input signals of odd and even clock shall be the same timing.

Note3: Please follow PSWG.

AUO Confidential For PROMATE Internal Use Only / 2017/11/23

## 6.4 Timing Characteristics

### 6.4.1 Timing Characteristics

Basically, interface timings described here is not actual input timing of LCD module but output timing of SN75LVDS82DGG (Texas Instruments) or equivalent.

| Signal             | Item       | Symbol             | Min   | Typ   | Max  | Unit |
|--------------------|------------|--------------------|-------|-------|------|------|
| Vertical Section   | Period     | Tv                 | 1034  | 1066  | 2048 | Th   |
|                    | Active     | Tdisp(v)           | 1024  | 1024  | 1024 | Th   |
|                    | Blanking   | Tbp(v)+Tfp(v)+PWvs | 10    | 42    | 1024 | Th   |
| Horizontal Section | Period     | Th                 | 750   | 844   | 2048 | Tclk |
|                    | Active     | Tdisp(h)           | 640   | 640   | 640  | Tclk |
|                    | Blanking   | Tbp(h)+Tfp(h)+PWhs | 110   | 204   | 1408 | Tclk |
| Clock              | Period     | Tclk               | 14.81 | 18.52 | 25   | ns   |
|                    | Frequency  | Freq               | 40    | 54    | 70   | MHz  |
| Frame rate         | Frame rate | F                  | 49    | 60    | 76   | Hz   |

**Note :** DE mode only

AUO Confidential For PROMATE Internal Use Only / 2017/11/23

### 6.4.2 Timing Diagram

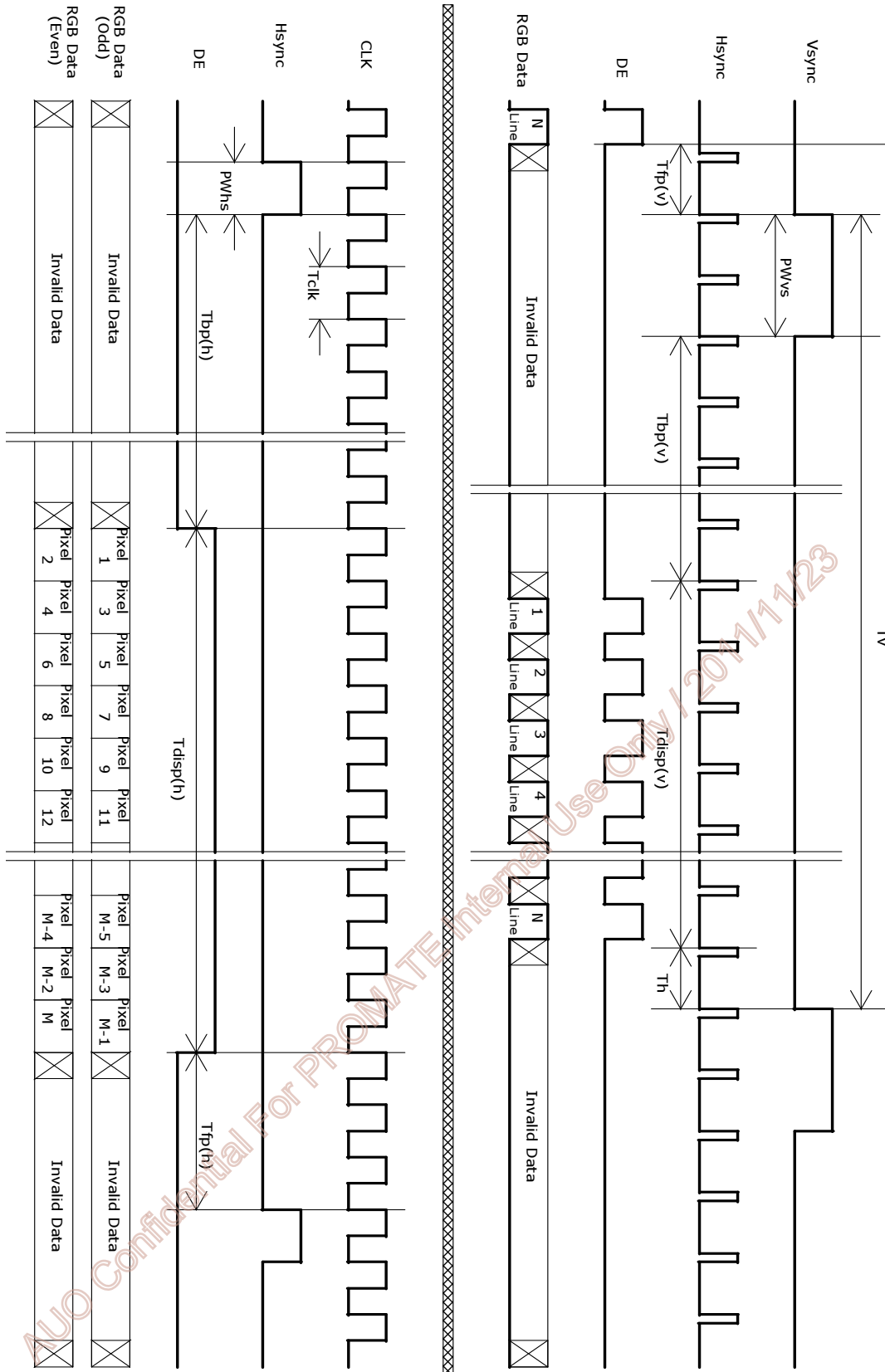

## 6.5 Power ON/OFF Sequence

VDD power and lamp on/off sequence is as follows. Interface signals are also shown in the chart. Signals from any system shall be Hi-Z state or low level when VDD is off.

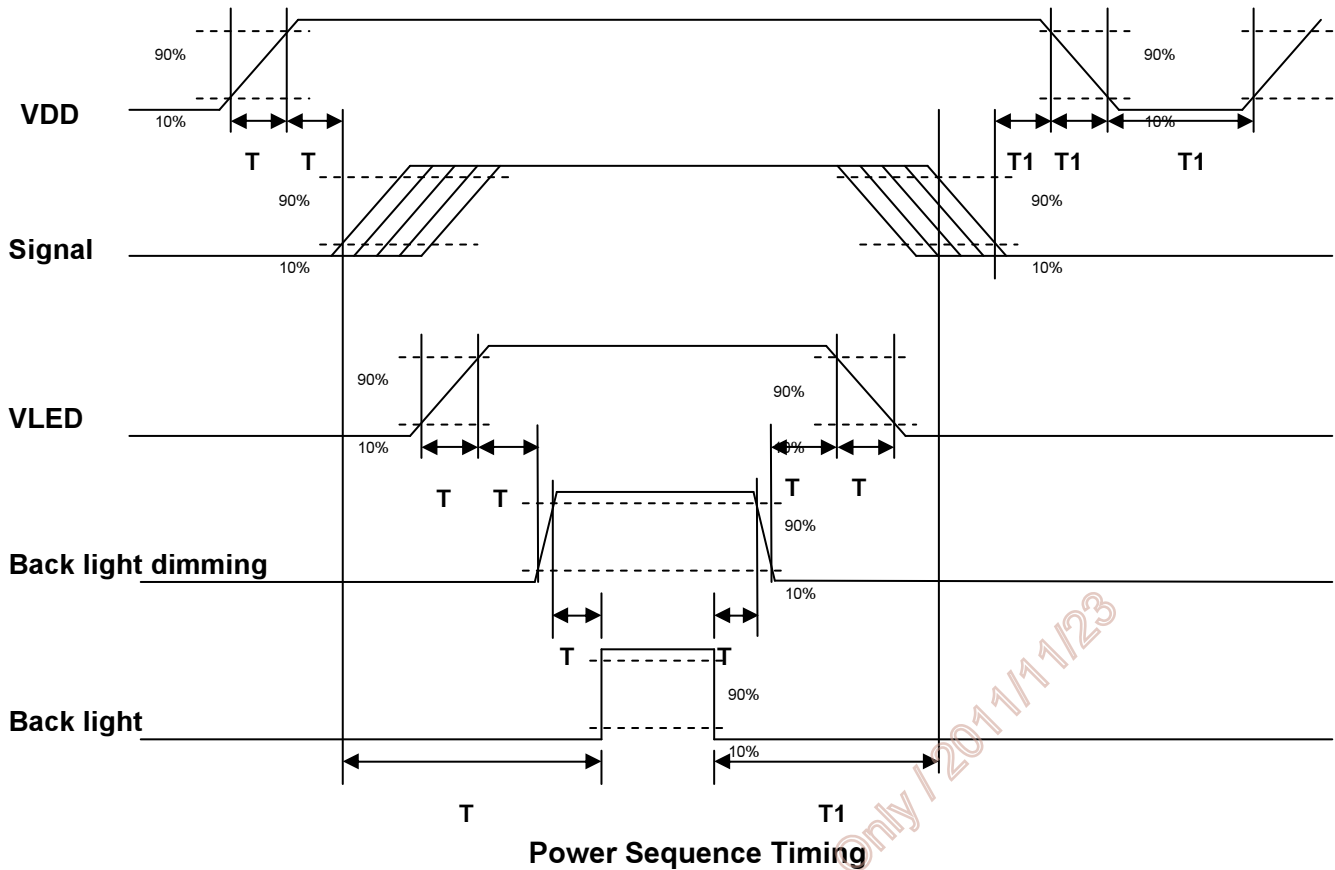

Power Sequence Timing

| Parameter | Value |      |      | Unit |
|-----------|-------|------|------|------|
|           | Min.  | Typ. | Max. |      |
| T1        | 0.5   | -    | 10   | [ms] |
| T2        | 30    | 40   | 50   | [ms] |
| T3        | 200   | -    | -    | [ms] |
| T4        | 0.5   | -    | 10   | [ms] |
| T5        | 10    | -    | -    | [ms] |
| T6        | 10    | -    | -    | [ms] |
| T7        | 0     | -    | -    | [ms] |
| T8        | 10    | -    | -    | [ms] |
| T9        | -     | -    | 10   | [ms] |
| T10       | 110   | -    | -    | [ms] |
| T11       | 0     | 16   | 50   | [ms] |



# Product Specification

G170EG01 V1

AU OPTRONICS CORPORATION

|     |      |   |    |      |
|-----|------|---|----|------|
| T12 | -    | - | 10 | [ms] |
| T13 | 1000 | - | -  | [ms] |

AUO Confidential For PROMATE Internal Use Only / 2017/11/23

## 7. Connector & Pin Assignment

Physical interface is described as for the connector on module. These connectors are capable of accommodating the following signals and will be following components.

### 7.1 TFT LCD Module

#### 7.1.1 Connector

| Connector Name / Designation | Interface Connector           |
|------------------------------|-------------------------------|
| Manufacturer                 | JAE or Compatible             |
| Type Part Number             | FI-XB30SSL-HF15 or Compatible |
| Mating Housing Part Number   | JAE FI-X30HL or Compatible    |

#### 7.1.2 Pin Assignment

| Pin# | Signal Name      | Pin# | Signal Name |
|------|------------------|------|-------------|
| 1    | RxOIN0-          | 2    | RxOIN0+     |
| 3    | RxOIN1-          | 4    | RxOIN1+     |
| 5    | RxOIN2-          | 6    | RxOIN2+     |
| 7    | GND              | 8    | RxOCLKIN-   |
| 9    | RxOCLKIN+        | 10   | RxOIN3-     |
| 11   | RxOIN3+          | 12   | RxEIN0-     |
| 13   | RxEIN0+          | 14   | GND         |
| 15   | RxEIN1-          | 16   | RxEIN1+     |
| 17   | GND              | 18   | RxEIN2-     |
| 19   | RxEIN2+          | 20   | RxECLKIN-   |
| 21   | RxECLKIN+        | 22   | RxEIN3-     |
| 23   | RxEIN3+          | 24   | GND         |
| 25   | GND (AGMODE+HVS) | 26   | NC          |
| 27   | GND              | 28   | VCC         |
| 29   | VCC              | 30   | VCC         |



## 7.2 Backlight Unit

Physical interface is described as for the connector on module. These connectors are capable of accommodating the following signals and will be following components.

| Connector Name / Designation  | Lamp Connector               |
|-------------------------------|------------------------------|
| Manufacturer                  | E&T or compatible            |
| Connector Model Number        | 3806K-F06Y-03R or compatible |
| Mating Connector Model Number | H208K-P06N-02B or compatible |

### 7.2.1 Signal for LED driver connector

| Pin# | Symbol     | Signal Name    |
|------|------------|----------------|
| 1    | VCC        | 12V            |
| 2    | VCC        | 12V            |
| 3    | GND        | GND            |
| 4    | GND        | GND            |
| 5    | Display on | 5V-On / 0V-Off |
| 6    | Dimming    | PWM Dimming    |

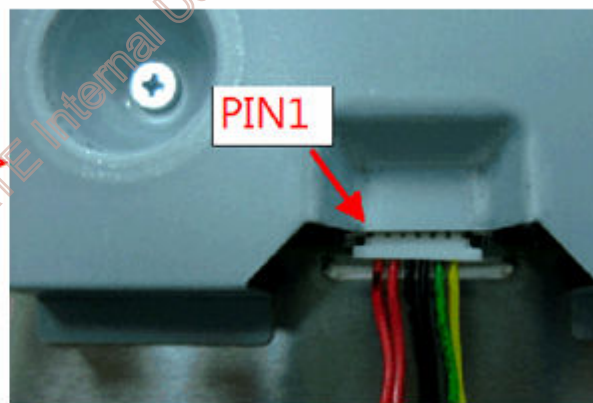
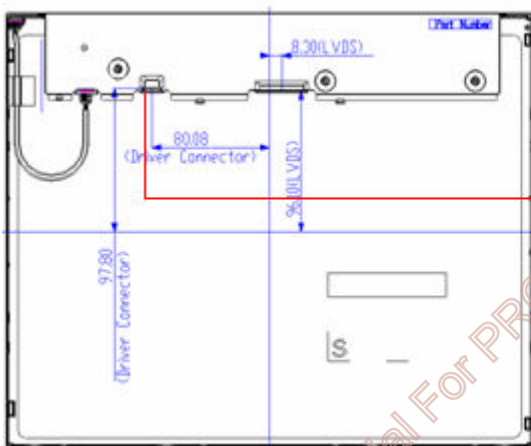

## 8. Reliability Test

Environment test conditions are listed as following table.

| Items                             | Required Condition  | Note |
|-----------------------------------|---|------|
| Temperature Humidity Bias (THB)   | Ta= 50°C, 80%RH, 300hours   |      |
| High Temperature Operation (HTO)  | Ta= 85°C, 300hours  |      |
| Low Temperature Operation (LTO)   | Ta= -30°C, 300hours   |      |
| High Temperature Storage (HTS)    | Ta= 85°C, 300hours  |      |
| Low Temperature Storage (LTS)     | Ta= -30°C, 300hours   |      |
| Vibration Test<br>(Non-operation) | Acceleration: 1.5 G<br>Wave: Random<br>Frequency: 10 - 200 - 10 Hz<br>Sweep: 30 Minutes each Axis (X, Y, Z)   |      |
| Shock Test<br>(Non-operation)     | Acceleration: 50 G<br>Wave: Half-sine<br>Active Time: 20 ms<br>Direction: ±X, ±Y, ±Z (one time for each Axis) |      |
| Drop Test                         | Height: 60 cm, package test   |      |
| Thermal Shock Test (TST)          | -20°C/30min, 60°C/30min, 100 cycles   |      |
| On/Off Test                       | On/10sec, Off/10sec, 30,000 cycles  |      |
| ESD                               | Contact Discharge: ± 8KV, 150pF(330Ω ) 1sec,<br>8 points, 25 times/ point.                                    | 1    |
|                                   | Air Discharge: ± 15KV, 150pF(330Ω ) 1sec<br>8 points, 25 times/ point.  |      |
| EMI                               | 30-230 MHz, limit 40 dBu V/m, 230-1000 MHz, limit 47 dBu V/m  |      |
| Altitude Test                     | Operation:10,000 ft<br>Non-Operation:30,000 ft  |      |

Note1: According to EN61000-4-2, ESD class B: Some performance degradation allowed. No data lost  
Self-recoverable. No hardware failures.

Note2:

- Water condensation is not allowed for each test items.
- Each test is done by new TFT-LCD module. Don't use the same TFT-LCD module repeatedly for reliability test.
- The reliability test is performed only to examine the TFT-LCD module capability.
- To inspect TFT-LCD module after reliability test, please store it at room temperature and room humidity for 24 hours at least in advance.
- No function failure occurs.

## 9. Label and Packaging

### 9.1 Shipping Label (on the rear side of TFT-LCD display)

The shipping label format is shown as below.



### 9.2 Carton Package

Max capacity : 8 TFT-LCD module per carton

Max weight: 14 kg per carton

Outside dimension of carton: 426(L)mm\*270(W)mm\*375(H)mm

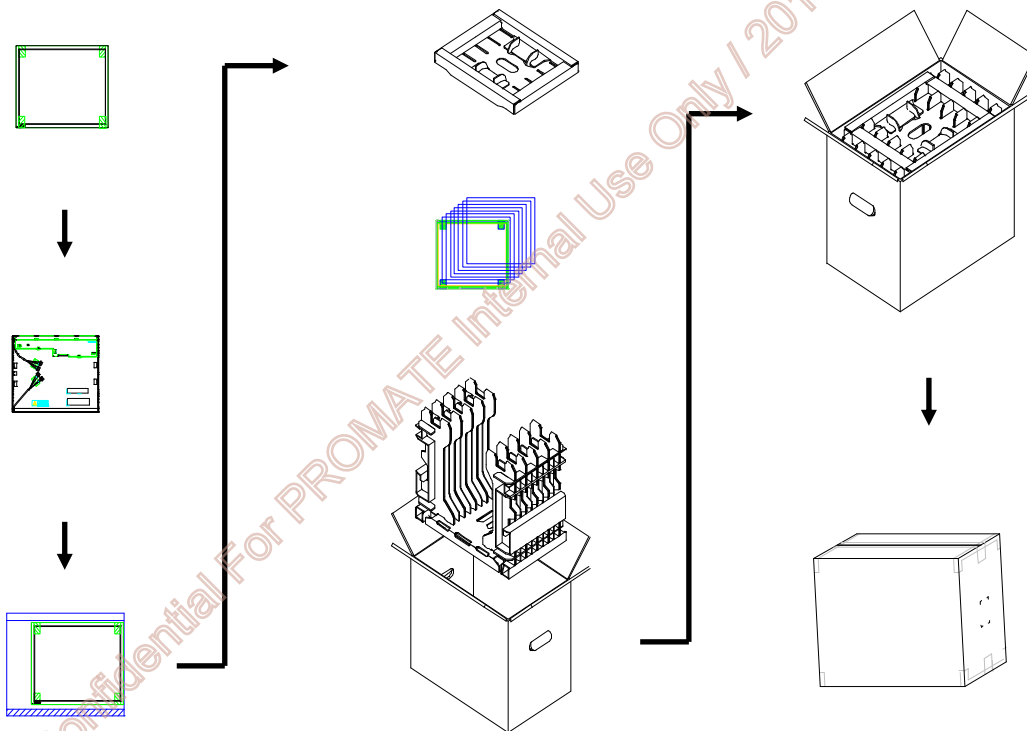

AUO Confidential For PROMATE Internal Use Only / 2017/1/23

## 10. Mechanical Characteristics

