



力帆&山本精密工业（中国）有限公司

PCB [Printed Circuit Board] Connectors
印刷电路板连接器

In-saiL[®]



PROFILE

COMPANY 公司简介

力帆&山本（中国）运营中心

力帆&山本（中国）运营中心隸屬於力山企業集團。集團自1982年於臺灣成立以來、一直堅持向客戶快速、準確地提供緊固系統零件、自動化零件、電子五金件、模具配件、機械加工工具等各種高質量的工業零部件。集團多年來致力於研發創新，以核心技術為中心，包括：環保製程技術、精密模具技術、數控加工技術、粉末冶金技術等。集團不僅具完善的研發管理制度，更在智權管理上努力耕耘，積極地以提升華人之國際競爭力為己任，並在企業社會責任與節能、減排、綠化、循環等環境保護方面全力推動與奉獻；

力山企業集團成立33年來，已經建立起5個產品製造中心，分佈於臺灣，新加坡，墨西哥，江蘇和廣東。購置了大量的精密製造設備，如數控車床，數控銑床，數控磨床，精密壓機和注塑機等3600餘套，具備系統的工業零件製造能力。也組建獨立運營中心3個（臺灣運營中心，新加坡運營中心和深圳運營中心），負責全球客戶的商務合作和技術支持。

力帆五金&山本精工，以力山企業集團為依託，將與注重品質和交期的客戶攜手共進、為全球製造工業的發展貢獻我們的智慧和力量。

- 1、各式組裝系統零件（緊固件，焊接件等）
- 2、精密金屬加工零件與工程塑膠組件
- 3、汽車，醫療，3C產品用之機械精密零組件
- 4、自動化用各種精密零組件
- 5、塑膠和衝壓模具用精密配件
- 6、各式機械加工工具和量具



In-sail® Dreams Chinese Dream!
力帆，扬帆中国梦!

In-sail & Sandum(China)Operation Center

In-sail & Sandum (China) Operation Center is part of Leasan Enterprise. Since its establishment in Taiwan in 1982, Leasan Enterprise Group has always insisted on quickly and accurately provide customers with various high-quality parts like fastening system parts, automation parts, electronic hardware, mold parts, and machining tools. The group has been committed to R&D and innovation for many years, focusing on core technologies, including environmental protection technology, precision molds technology, CNC machining technology, powder metallurgy technology. The group not only a sound R&D management system but also works actively to enhance the international competitiveness of the Chinese mission in the management and fully promotes corporate social responsibility and energy conservation, emission reduction, greening, recycling, and other environmental protection and dedication.

Leasan Enterprise Group was established 33 years ago, it has established 5 manufacturing centers, which there are located in Taiwan, Singapore, Mexico, Jiangsu, and Guangdong. The purchase of a large number of high-precision manufacturing equipment, such as CNC lathes, CNC milling machines, CNC grinders, precision presses, and injection molding machines are more than 3,600 sets, with a systematic industrial part manufacturing capabilities. 3 independent operation centers (Taiwan operation center, operation center in Singapore, and Shenzhen operation center) have also been established to be responsible for business cooperation and technical support for the global customers.

In-sail & Sandum Precision relying on Leasan Enterprise Group will work together with customers who focus on quality and delivery and contribute our wisdom and strength to the development of the global manufacturing industry.

1. All kinds of assembled parts system (fasteners, welding parts, etc.)
2. Precision metal machining parts and engineering plastic components and mechanical precision components
3. The automotive, medical, 3C products using
4. Automation of various precision components
5. Plastic precision parts and stamping dies
6. Kinds of machining tools and gauges

Product Capability / 制造能力



- Auto-lathe turning:
PE : $\Phi 0.5-20\text{mm}$ Tol. $\pm 0.01\text{mm}$
- CNC lathe turning:
PE : $\Phi 0.5-250\text{mm}$ Tol. $\pm 0.005\text{mm}$
- CNC Milling:
800X600mm (LxW), Tol. $\pm 0.01\text{mm}$
- Grinding:
Tol. $\pm 0.002\text{mm}$
- Screw heading & rolling:
Metric M0.8-M36
Unified Imperial #0-2"
- Stamping:
1200T max
- 自动车床加工: 直径0.5-20mm
公差 0.01mm
- 数控车床加工: 直径0.5-250mm
公差 0.005mm
- 数控铣削加工: 800X600mm
公差 $\pm 0.01\text{mm}$
- 外圆磨削加工: 公差 $\pm 0.002\text{mm}$
- 螺丝加工: 公制 M0.8-M36
英制 #0-2"
- 冲压加工: 1200 吨位内

- Automatic Lathe / 自动车床
- CNC Lathe / 数控车床
- CNC Machine / CNC 加工中心
- Precision Grinding / 精密磨削
- Ultraprecision Machining / 超精加工
- Screw Machine / 螺丝机
- Stamping Equipment / 冲压设备
- Injection machine / 注塑机

In-sail & Sandum is your choice!

力帆&山本 值得信赖!

Quality Management / 品质控制

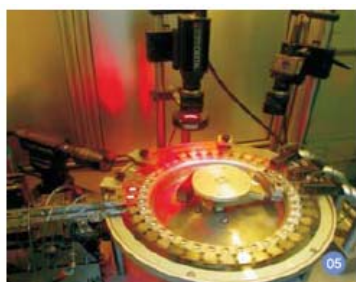

Superior product quality whilst protecting resources as much as possible is a matter of course for us. After all, precision is our business.

We set up total management quality systems following ISO9001:2015, from the IQC to IPQC to OQC, we strictly execute customer quality requirement to achieve quality target.

In-saiL woned advanced quality control and inspection facilities, is capable to perform mechanical property, diemension & contour and corrosion-resistance test at the incoming, in-process, and outgoing stages.

高质量的产品和环境保护都是我们所追求的目标，我们产品的高质量最多的体现于高精度。

力帆精密依照ISO9001：2015建立了完整的品质系统，从IQC到PQC再到OQC，严格管制，全员参与。严格遵照客户要求，达成品质目标。

力帆精密有先进的品质管控和检测设备，能够来料加工，制程和成品检查各阶段实施诸如机械性能检测，尺寸和轮廓检测及耐腐蚀验证等。

- 01 Pull Tester / 拉力计
- 02 Projector / 投影仪
- 03 Durometer / 硬度计
- 04 Coating Analyzer / 镀层分析仪
- 05 Automatic Optic Inspector / 全自动品检机
- 06 CMM / 三次元
- 07 Salt Spray Tester / 盐雾测试机
- 08 Tensile Machine / 拉力试验机



TABLES OF CONTENTS 目录

Part 1 Press-Fit element

	Press-Fit Technology	07	Overview of Press-Fit Technology	压装工艺概述
	PowerOne	09	Single-Piece Power Element	一体型
	PE01 (IT-TRT)	11	Press-Fit with internal thread, two rows	通孔内螺纹, 双排插脚型
	PE02 (IT-TRB)	12	Press-Fit with internal blind-hole thread, two rows	盲孔内螺纹, 双排插脚型
	PE03 (IT-C)	13	Press-Fit with internal thread circumference	通孔内螺纹, 四周插脚型
	PE04 (IT-FP)	15	Press-Fit with internal thread, full plain	盲孔内螺纹, 平面插脚型
	PE05 (ET-FP)	16	Press-Fit with external thread, full plain	外螺纹, 平面插脚型
	PE06 (RA-TRA)	17	Press-Fit right angled, two rows	双排插脚直角型
	PE07 (RA-TRB)	18	Press-Fit right angled, two rows (Chamfering)	双排插脚直角型 (倒角处理)
	PE08 (RA-FPA)	19	Press-Fit right angled, full plain	平面插脚直角型
	PE09 (RA-FPB)	20	Press-Fit right angled, full plain (Chamfering)	平面插脚直角型 (倒角处理)
	PE10 (RA-FPU)	21	Press-Fit right angled, full plain (U-shape)	平面插脚直角型 (U型槽)
	PowerTwo	22	Two-Piece Power Element	双部件组合型
	PE11 (TP-GET)	24	Press-Fit two-part, ground element (Base-Part)	双部件, 内孔双排插脚型 (底座)
	PE12 (TP-GEC)	25	Press-Fit two-part, ground element (Base-Part)	双部件, 内孔平面插脚型 (底座)
	PE13 (TP-SERI)	26	Press-Fit two-part, Socket (Female Thread)	双部件, 插座 (圆头内螺纹)
	PE14 (TP-SESE)	27	Press-Fit two-part, Socket (Female Thread)	双部件, 插座 (方头内螺纹)
	PE15 (TP-SERH)	28	Press-Fit two-part, Socket (Female Though-Hole)	双部件, 插座 (圆头光孔)
	PE16 (TP-SESH)	29	Press-Fit two-part, Socket (Female Though-Hole)	双部件, 插座 (方头光孔)
	PE17 (TP-SERE)	30	Press-Fit two-part, Pin (Male Thread)	双部件, 插针 (圆头外螺纹)
	PE18 (TP-SESI)	31	Press-Fit two-part, Pin (Male Thread)	双部件, 插针 (方头外螺纹)

TABLES OF CONTENTS 目录

Part 2 THR element

	THR Technology	32	Overview of Through-hole Reflow	通孔回流焊工艺概述
	PE19 (THR-IHT)	33	THR with internal through-hole thread	通孔内螺纹
	PE20 (THR-IBT)	34	THR with internal blind-hole thread	盲孔内螺纹
	PE21 (THR-EH)	35	THR with external thread	外螺纹

Part 3 SMD element

	PE22 (SMD-ET)	37	SMT with external thread	外螺纹型
	PE23 (SMD-ETP)	38	SMT with external thread with Pin	带 Pin 针 外螺纹型
	PE24 (SMD-IBT)	39	SMT with internal blind-hole thread	盲孔内螺纹型
	PE25 (SMD-IBTP)	40	SMT with internal blind-hole thread with Pin	带 Pin 针盲孔内螺纹型
	PE26 (SMD-FT)	41	SMT with internal blind-hole thread (groove)	盲孔内螺纹型 (带沟槽)
	PE27 (SMD-FTP)	42	SMT with internal blind-hole thread with Pin (groove)	带 Pin 针盲孔内螺纹型 (带沟槽)
	PE28 (SMD-ITT)	43	SMT with internal through-hole thread	通孔内螺纹型
	PE29 (SMD-FTT)	44	SMT with internal through-hole thread (groove)	通孔内螺纹型 (带沟槽)
	PE30 (SMD-RA)	45	SMT terminal right angled	直角型
	PE31 (SMD-RAP)	46	SMT with right angled with Pins	直角插脚型
	PE32	47	SMT with external thread	外螺纹型
	PE33	48	SMT with internal blind-hole thread	盲孔内螺纹型

Press-Fit Technology

1. As a solder free fastening technology, press-fit technology frequently offers an attractive alternative to simple soldering technology.
2. An effective electrical press-fit connection is created by pressing a pin into plated through hole of a circuit board and – as part of cold welding process – generating a gas-tight electrical connection.
3. The through-hole plating for a press-fit system is essentially made in the same way as the holes for accepting components for THT soldering. Thus there are no hanges required in the PCB manufacturing process.
4. One outstanding characteristic of the press-fit system compared to the soldering system is that it produces not only an electrical but also an extraordinarily strong mechanical connection between the inserted components and the PCB.

With regard to long-term reliability, the press-fit is convincing since it has the lowest FIT value (Failure in Time) of the overall system. It is to 30 times better than that of an SMT solder joint. A single solid press pin has a typical extraction force of 100N or approximately 70% of the insertion force. Therefore press-fit connections are predestined to provide not only electrical but also mechanical connection solutions for electrical components.

If after press insertion a solid press pin in a 2.4mm thick printed circuit board fits on each corner with more than 3 against the sleeve, the press connection zone has a lower electrical resistance than the brass pin itself and thus does not pose an electrical or thermal bottleneck. The connection surface angle is normally much greater, which provides a generous safety buffer for the electrical connection.

Notice

The processing of press-fit elements fits seamlessly into the production process and is thus very cost-effective. Multiple power elements can be fitted simultaneously using press-fit tools. Compared to soldering, the printed circuit boards are not subjected to thermal loads.

1. Other components should be spaced at least 4mm away from the press-fit hole.
2. The hole should be at least 3mm away from the edge.
3. No special tools are necessary for the pressing process. A simple lever press is usually sufficient.
4. The insertion force per pin should be at least 40N. Typically this force is around 150N/pin.
5. The press connection area must be supported during the pressing process.
6. The press stroke should be 90° to the PCB. The pins should protrude slightly from the PCB after the pressing process.
7. If two-part press-fit elements are used, the base-part must always be fitted first to the PCB.
8. Press-in-process should be made after all soldering processes because of high heat absorption of power elements.

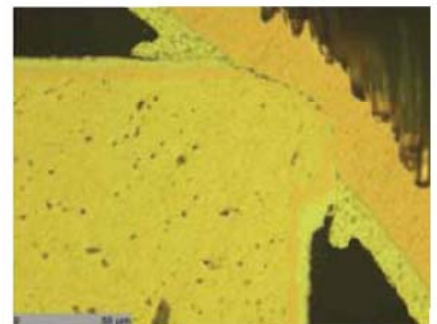
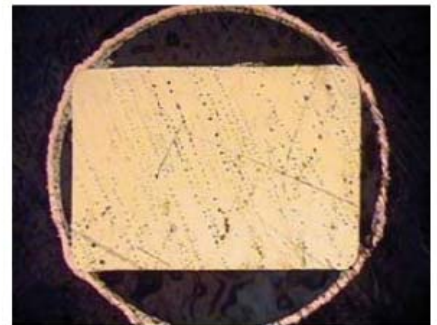
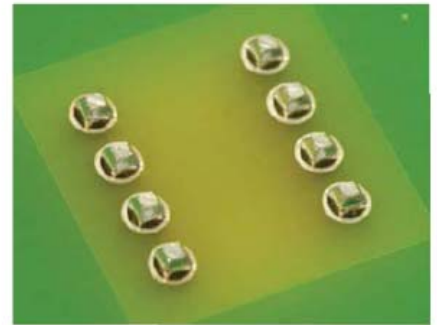

Continuous and extremely homogenous material transition between press pin and through-hole plating.

Required connection surface angle $\approx 3^\circ$

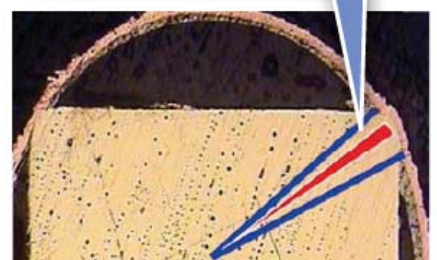

Advantages of the Press-Fit technology

1. Very high ampacity, ideally suited for high continuous and peak currents.
2. Press-fit connections show extremely high environmental stability.
3. Low-resistance connection means low self heating, hence less heat must be dissipated through the system.
4. No heat development on sensitive components and no thermal stress of the circuit board.
5. Extremely stable mechanical.
6. No problems with cold solder joints.
7. High mechanical retaining forces.
8. Double-sided mounting of circuit board is possible.
9. Much higher long-term reliability as for solder connections.
10. More secure than soldering and screw connections.
11. No changes in the production of circuit boards necessary.

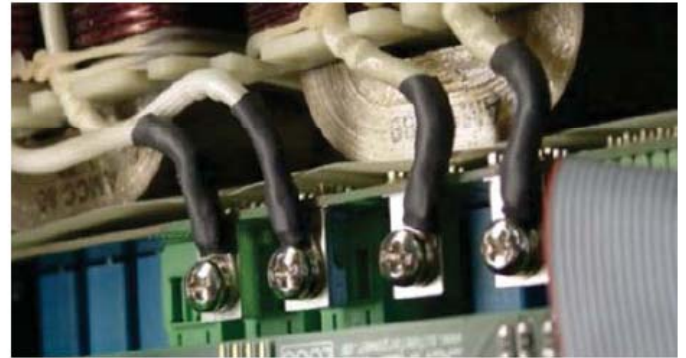

Press-Fit element for currents of up to 300 A



Press-Fit element for currents of up to 160 A

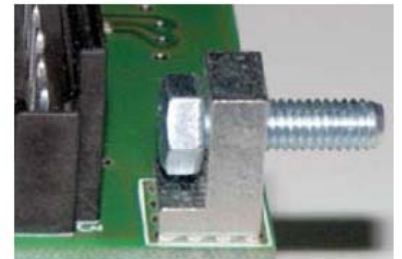

Angled power element for connecting the assembly with the housing



DC power connection up to 120 A

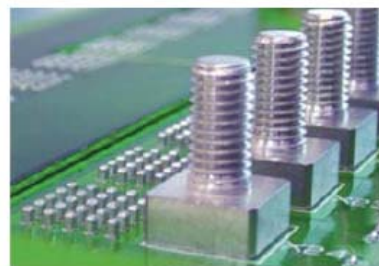

Double-sided mounting

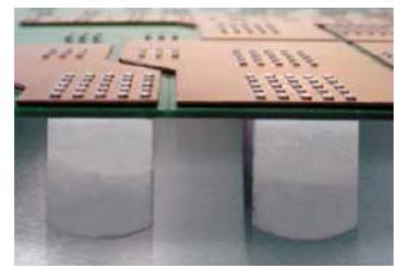

Press-fitting of power element: PCB with copper bar

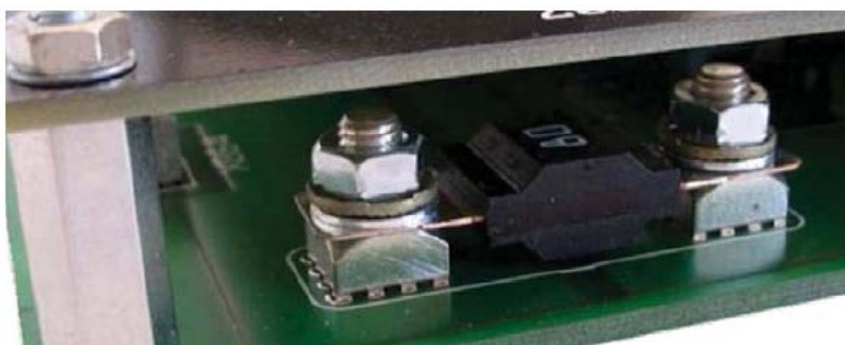

Option for fitting a fuse

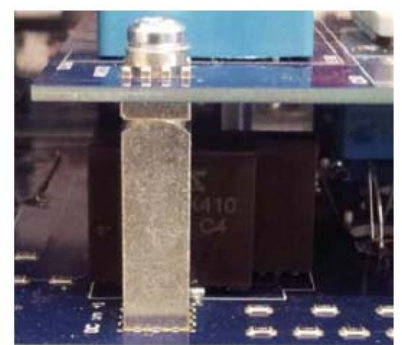

High current Board-to-Board connection

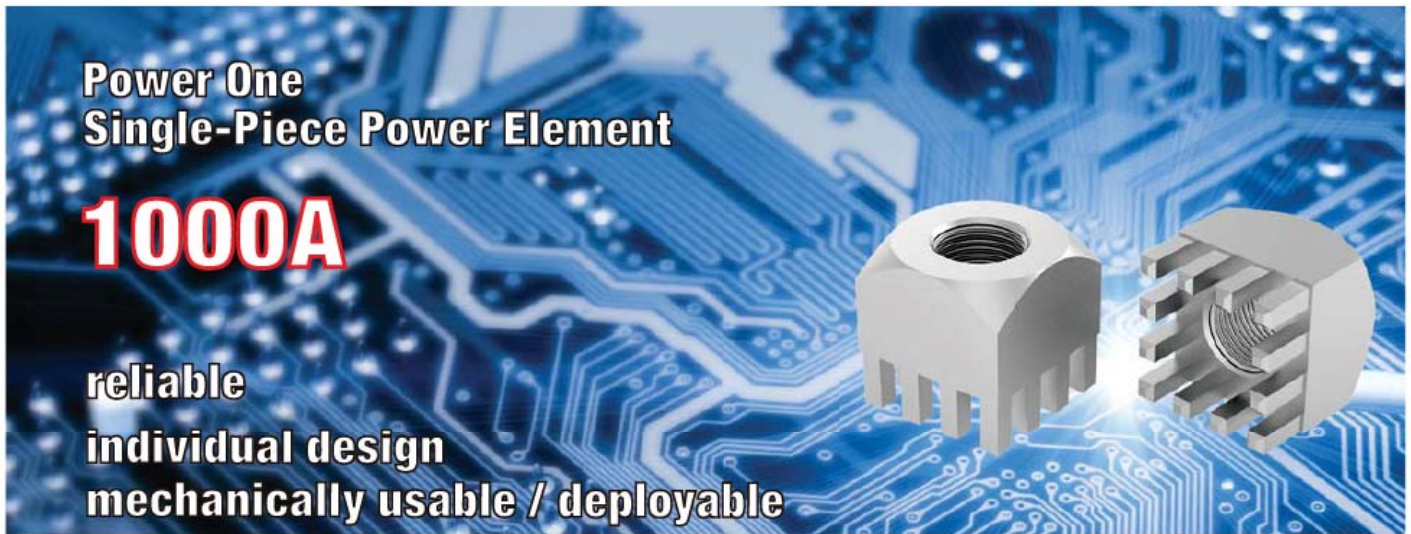

**Power One
Single-Piece Power Element**

1000A

**reliable
individual design
mechanically usable / deployable**

Single-piece Power Elements are used for the supply and distribution of high currents in connection with circuit board based systems. Depending on the pin arrangement and the layout, currents of up to 1,000A are possible. Meanwhile this product group has been successfully used in the field in thousands of various designs. The manufacturing method allows individual adaptations regarding design and dimensions. That is the reason why Power Elements perfectly qualify as connecting element for fuses, IGBTs, switches and cables to the circuit board or as contact element for board-to-board respectively board-to-case.

Application Possibilities

- Board-to-board over 90° or packaging
- Wire-to-board screw connection of ring terminals
- Electro mechanics such as hinges and case mounting
- Spacers
- Retainers / fastenings of switches, fuses, IGBTs
- Any combination of all these and much more

Processing

In-saiL PowerOne Power Elements are pressed in into the circuit board. Soldering is not necessary. Therefore, the PCBs are not exposed to temperature stress. This processing step easily blends in to the processing chain and is highly cost efficient. With the aid of the corresponding Press Fit tools, several Power Elements can be pressed in simultaneously.

- For assembling prototypes, no special equipment is needed for pressing in, a simple toggle press is sufficient.
- The circuit board needs support during the pressing procedure.
- The pressing force must be executed in a 90° angle to the circuit board.
- After the pressing process the pins should stand out of the drilled hole (ca. 0.2 – 0.5 mm).
- Plated through holes of the circuit board must be executed according to our indications.
- PowerOne high current terminal blocks and spacers are manufactured for pressing, soldering is not intended.

Technical Data

Current carrying capacity per pin at 20 °C	~ 10 /15 A (areal / circumferential pins)
Current carrying capacity per pin at 85 °C	~ 6 /10 A (areal / circumferential pins)
Material	CuZn39Pb3
Surfaces	Tin-plated (standard)
	further surfaces such as nickel, silver, nickel / gold and others on demand

Dimensions

Length x width	from 5 x 5 to 22 x 22 mm
Height	from 3 mm individually
Height above PCB	from 3 mm individually
Pin length	up to 7.5 mm (standard of 3.5 mm)
Pin diagonal	1.6 mm standard
	others on demand

Circuit Board

Base material	FR4 (EPGC202)
PCB thickness	from 1.5 mm
Drilling diameter	1.60 ± 0.025 mm
Final diameter HAL surface	1.45 ± 0.05 mm
chemical surface	1.475 ± 0.05 mm
Copper in hole thickness	min. 25 µm, max. 80 µm

Processing Parameters

Press-in force	min. 40 N per Pin max. 250 N per Pin
Retention force	60 – 80 % of the press-in force
Press-in speed	100 – 250 mm /min

Circuit Board Design

Via Specification For Chemical Surfaces

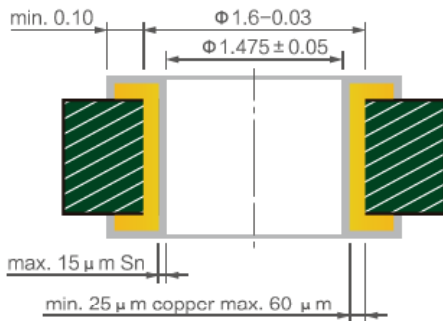

Via Specification For HAL (Hot Air Solder Leveling)

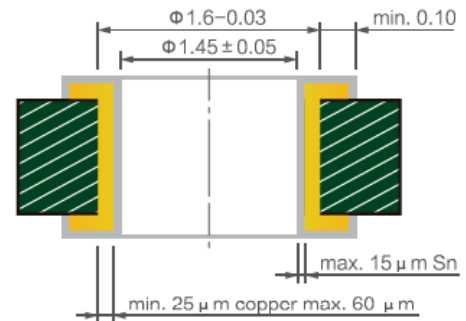

Torques

The torques indicated in the table are based on DIN 267 part 25. Different material combinations or different thread lengths of the connectors are not regarded here.

Torques for Brass

Thread	M2.5	M3	M4	M5	M6	M8	M10	M12
(Nm)	0.3	0.5	1.2	2.2	3.9	9.0	17.0	35.0

Current Carrying Capacity

The current carrying capacity of a Press Fit connection needs to be seen in the context of the overall system. The Press Fit zone has a very low electrical contact resistance of 100 – 200 Ω. The limiting factor therefore usually lies in the circuit board layout or in the connection of a feed line.

Reference values for a pre-dimensioning can be found under Technical Data on page 09.

Derating Curve

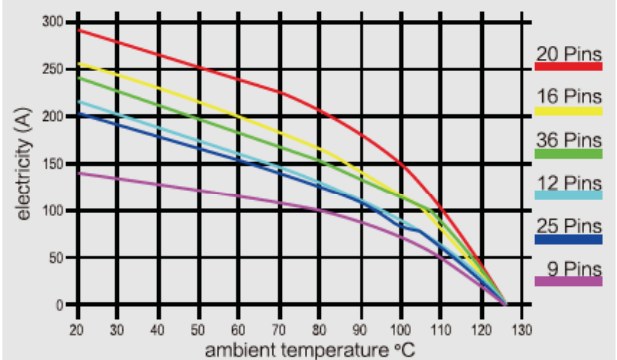

Overview of PowerOne products

Customer Specific	through hole vertical (two-rows)	blind hole vertical (two-rows)	through hole vertical (circumference)	blind hole vertical (full plain)	bolt	bracket through hole (two-rows)	bracket through hole (full plain)	U groove bracket (full plain)
Pins								
4					M3			
6					M3, Ø3.2			
8					M2.5, M4, M5, M6, Ø4.2, Ø5.2			
9					M3, M4, M5, Ø3.2			
10					M6, M8, Ø6.2, Ø8.2			
12					M4, M5, Ø10.2			
16					M4, M5, M6, Ø4.2, Ø5.2			
20					M8, M10			
25					M6, M8, Ø5.2, Ø6.2, Ø8.2			
36					M10, M12, Ø8.2, Ø10.2			

All threads are available in UNC

Supplies

Based on your different requirements, we also provide some relevant products at the back of this brochure. For further inquiries, please contact our sales representative.

PE01 (IT-TRT)



Features

- The cable and fuse can be fixed on PCB
- UNC thread or customer specific modifications on demand

特征

- 可将电缆线、保险丝固定在电路板上
- 可按客户需求提供 UNC 螺纹或进行定制

Drawings

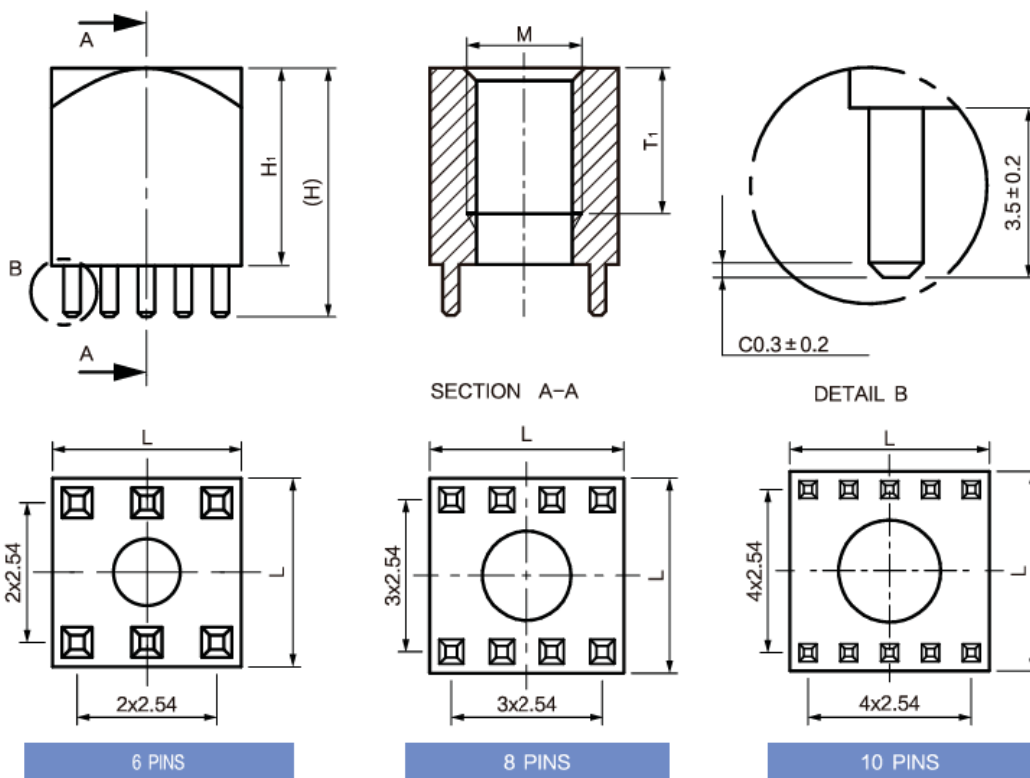

Technical Data

PROPERTIES	
Material	CuZn39Pb3
Surface	Tin
Drill Hole Diameter	1.6mm
Final Hole Diameter	1.475mm
Heat Resistance	-55 °C up to +150 °C
Retaining Force	as per IEC 352-5

Drawing No.	M	T ₁	H	H ₁	L	Pins	IR (A)	Tightening Torque
LFPE0101	M3	5	9.5	6	7	6	100	0.5Nm
LFPE0102	M4	6	10.5	7	9	8	160	1.2Nm
LFPE0103	M5	6	10.5	7	9	8	160	2.2Nm
LFPE0104	M8	10	17	13.5	13	10	240	9Nm

Dimension in mm

PE02 (IT-TRB)



Features

- The cable and fuse can be fixed on PCB
- UNC thread or customer specific modifications on demand

特征

- 可将电缆线、保险丝固定在电路板上
- 可按客户需求提供 UNC 螺纹或进行定制

Drawings

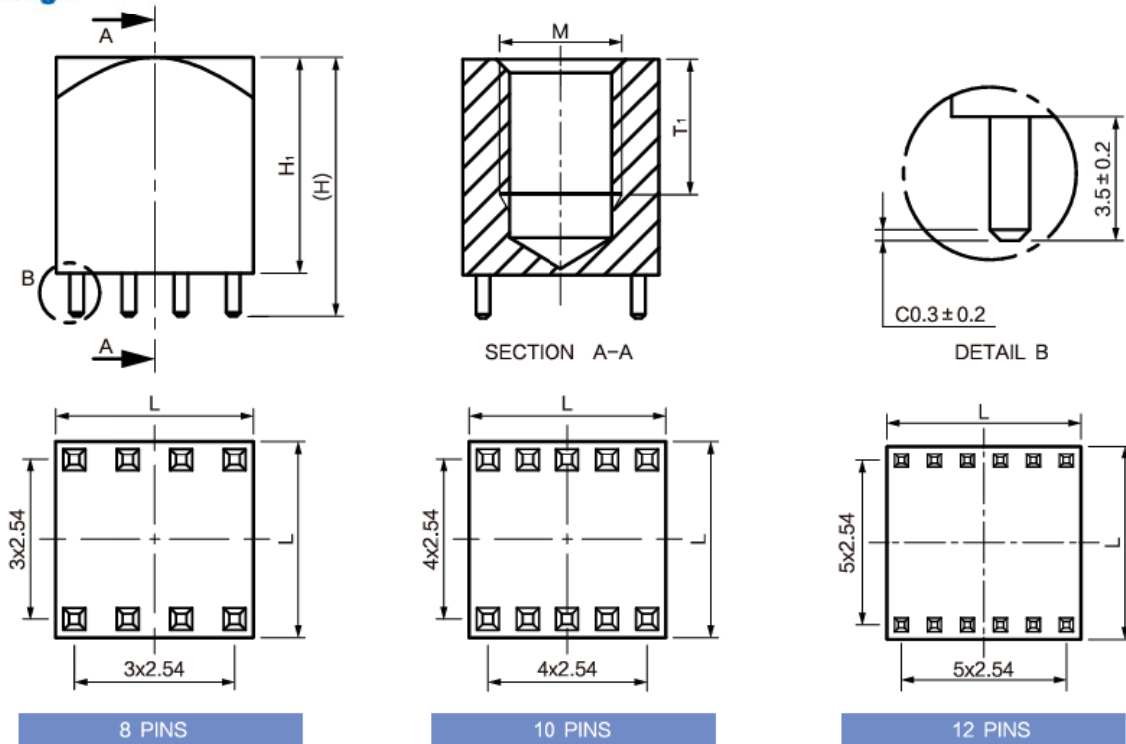

Technical Data

PROPERTIES	
Material	CuZn39Pb3
Surface	Tin
Drill Hole Diameter	1.6mm
Final Hole Diameter	1.475mm
Heat Resistance	-55 °C up to +150 °C
Retaining Force	as per IEC 352-5

Drawing No.	M	T ₁	H	H ₁	L	Pins	IR (A)	Tightening Torque
LFPE0201	M6	9	17	13.5	10	8	160	4Nm
LFPE0202	M8	10	17	13.5	13	10	240	9Nm
LFPE0203	M10	11	21	17.5	16	12	320	17Nm

Dimension in mm

PE03 (IT-C)

Features

- The cable and fuse can be fixed on PCB
- UNC thread or customer specific modifications on demand

特征

- 可将电缆线、保险丝固定在电路板上
- 可按客户需求提供 UNC 螺纹或进行定制



Drawings

Full thread type

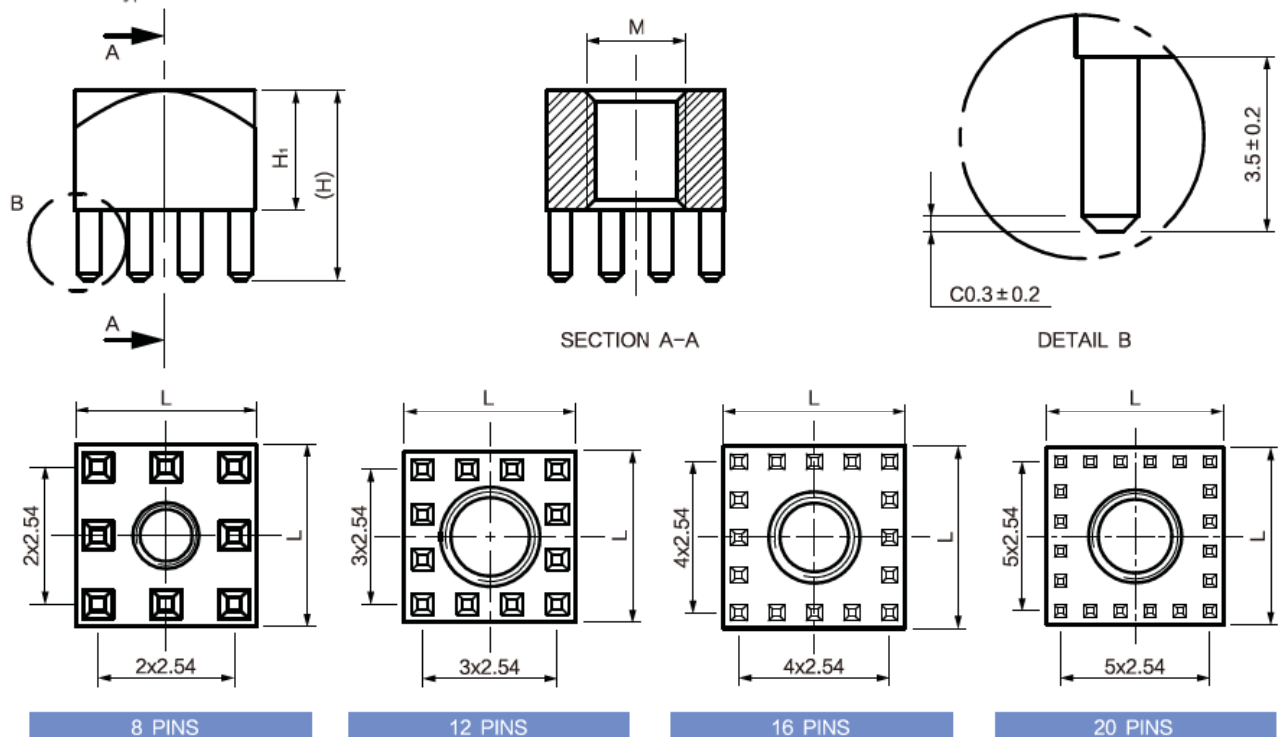

Technical Data

PROPERTIES	
Material	CuZn39Pb3
Surface	Tin
Drill Hole Diameter	1.6mm
Final Hole Diameter	1.475mm
Heat Resistance	-55 °C up to +150 °C
Retaining Force	as per IEC 352-5

Drawing No.	M	H	H ₁	L	Pins	IR (A)	Tightening Torque
LFPE0301	M2.5	9.5	6	7	8	130	0.29Nm
LFPE0302	M4	9.5	6	9	12	175	1.2Nm
LFPE0303	M5	9.5	6	9	12	175	2.5Nm
LFPE0304	M6	17	13.5	13	16	240	3.9Nm
LFPE0305	M8	17	13.5	13	16	340	9Nm
LFPE0306	M8	17	13.5	16	20	340	9Nm
LFPE0307	M10	21	17.5	16	20	340	17Nm

Dimension in mm

Drawings

Non full thread

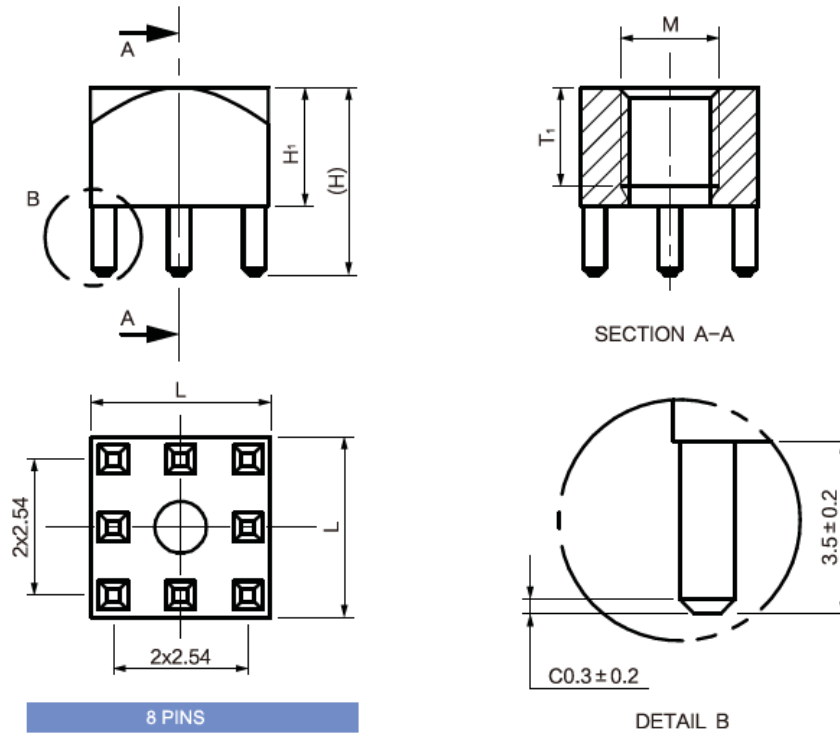

Technical Data

PROPERTIES	
Material	CuZn39Pb3
Surface	Tin
Drill Hole Diameter	1.6mm
Final Hole Diameter	1.475mm
Heat Resistance	-55 °C up to +150 °C
Retaining Force	as per IEC 352-5

Drawing No.	M	H	H ₁	T ₁	L	Pins
LFPE0308	M2.5	9.5	6	5	7	8

Dimension in mm

PE04 (IT-FP)

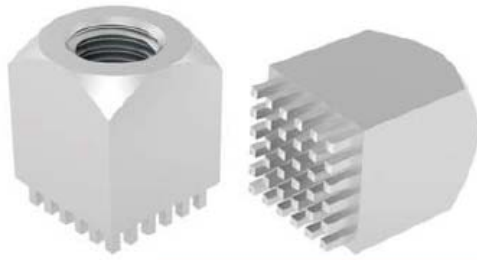

Features

- The cable and fuse can be fixed on PCB
- UNC thread or customer specific modifications on demand

特征

- 可将电缆线、保险丝固定在电路板上
- 可按客户需求提供 UNC 螺纹或进行定制

Drawings

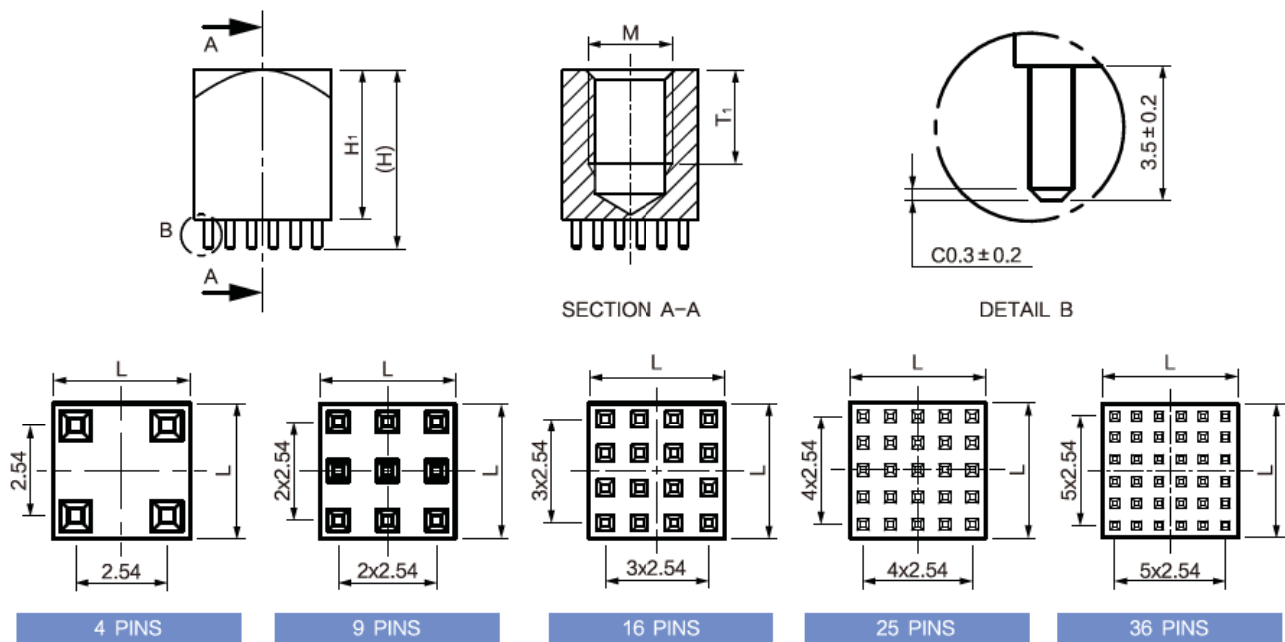

Technical Data

PROPERTIES	
Material	CuZn39Pb3
Surface	Tin
Drill Hole Diameter	1.6mm
Final Hole Diameter	1.475mm
Heat Resistance	-55 °C up to +150 °C
Retaining Force	as per IEC 352-5

Drawing No.	M	T ₁	H	H ₁	L	Pins	I R (A)	Tightening Torque
LFPE0401	M3	3.5	9.5	6	7	9	160	0.5Nm
LFPE0402	M3	4	10.5	7	5	4	70	0.5Nm
LFPE0403	M4	4	10.5	7	9	16	180	1.2Nm
LFPE0404	M5	4	10.5	7	9	16	180	2.2Nm
LFPE0405	M6	6.5	14	10.5	10	16	240	3.9Nm
LFPE0406	M8	8	17	13.5	13	25	250	9Nm
LFPE0407	M10	11	21	17.5	16	36	340	17Nm

Dimension in mm

PE05 (ET-FP)

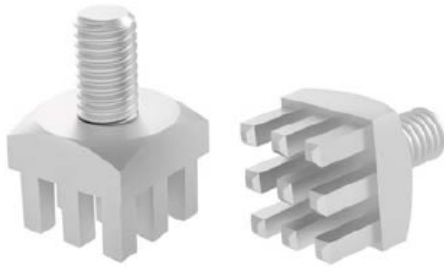

Features

- The cable and fuse can be fixed on PCB
- UNC thread or customer specific modifications on demand

特征

- 可将电缆线、保险丝固定在电路板上
- 可按客户需求提供 UNC 螺纹或进行定制

Drawings

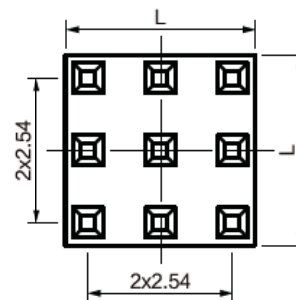
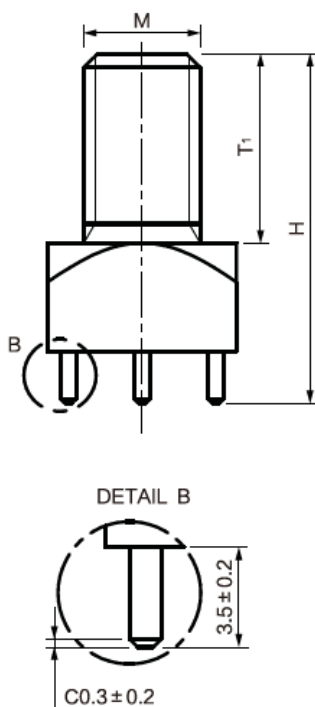

9 PINS

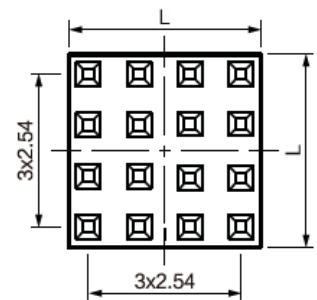

16 PINS

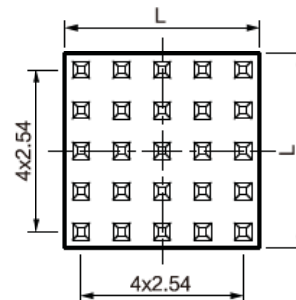

25 PINS

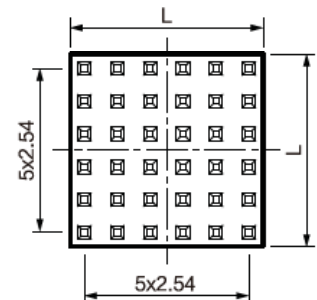

36 PINS

Technical Data

PROPERTIES	
Material	CuZn39Pb3
Surface	Tin
Drill Hole Diameter	1.6mm
Final Hole Diameter	1.475mm
Heat Resistance	-55 °C up to +150 °C
Retaining Force	as per IEC 352-5

Drawing No.	M	H	T ₁	L	Pins	I R (A)	Tightening Torque
LFPE0501	M3	11	5	7	9	130	0.5Nm
LFPE0502	M4	12.5	6	7	9	130	1.2Nm
LFPE0503	M4	13	6	9	16	130	1.2Nm
LFPE0504	M5	15.5	8	7	9	130	2.2Nm
LFPE0505	M5	16	8	9	16	180	2.2Nm
LFPE0506	M6	19	10	13	25	250	3.9Nm
LFPE0507	M8	24	13	13	25	250	9Nm
LFPE0508	M10	27.5	16	16	36	340	17Nm
LFPE0509	M12	41.5	30	18	36	340	17Nm

Dimension in mm



PE06 (RA-TRA)

Features

- PCB connection for fixing cable lugs
- UNC thread or customer specific modifications on demand
- As a fixing element for assembly onto housing etc.
E.g. for the connection of high current relays

特征

- 可将电缆线固定在电路板上
- 可按客户需求提供 UNC 螺纹或进行定制
- 可作为固定元件将部件固定于外壳等。
例如：可用于连接大电流继电器

Drawings

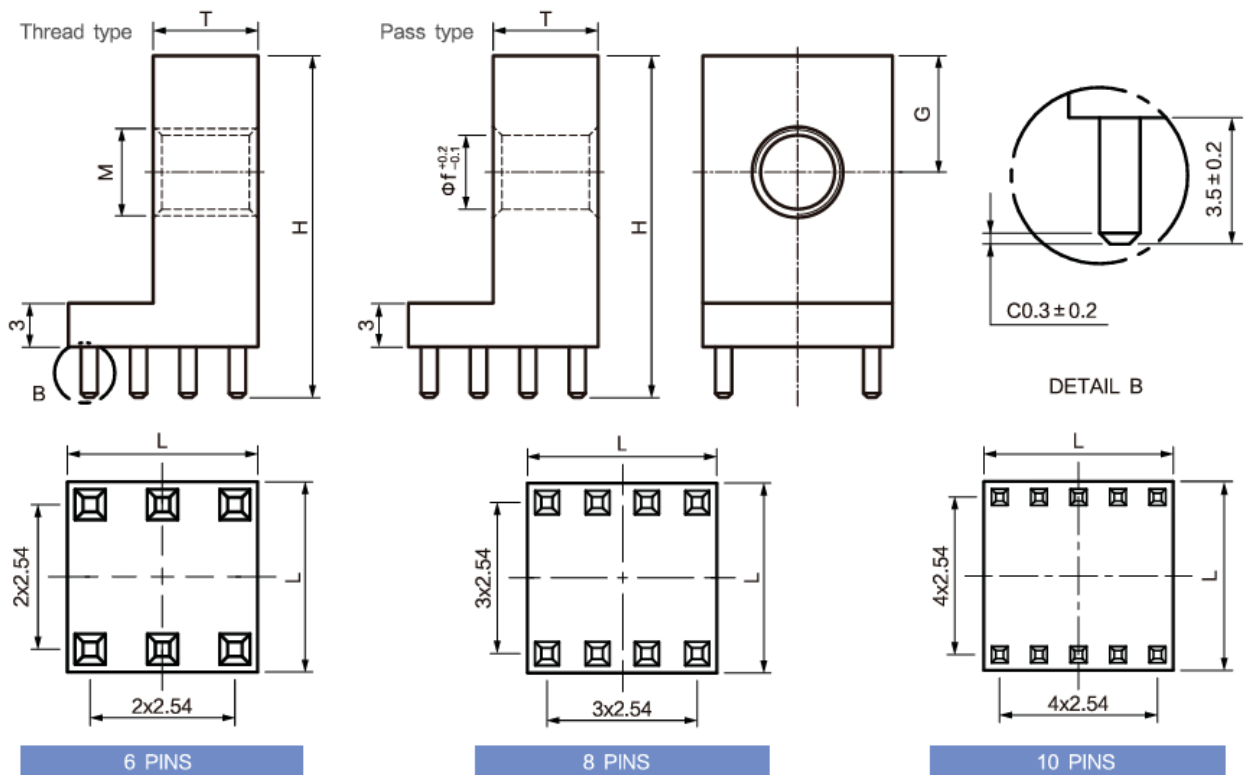

Technical Data

PROPERTIES	
Material	CuZn39Pb3
Surface	Tin
Drill Hole Diameter	1.6mm
Final Hole Diameter	1.475mm
Heat Resistance	-55 °C up to +150 °C
Retaining Force	as per IEC 352-5

Drawing No.	M/φf	H	T	G	L	Pins	I R (A)	Tightening Torque
LFPE0601	M3	17.5	3.8	5	7	6	100	0.5Nm
LFPE0602	M4	17.5	5	5	9	8	160	1.2Nm
LFPE0603	M5	17.5	5	5	9	8	160	2.2Nm
LFPE0604	M6	23.5	8	8	13	10	240	3.9Nm
LFPE0605	M8	23.5	8	8	13	10	240	9Nm
LFPE0606	φ3.2	17.5	3.8	5	7	6	100	0.5Nm
LFPE0607	φ4.2	17.5	5	5	9	8	160	1.2Nm
LFPE0608	φ5.2	17.5	5	5	9	8	160	2.2Nm
LFPE0609	φ6.2	23.5	8	8	13	10	240	3.9Nm
LFPE0610	φ8.2	23.5	8	8	13	10	240	9Nm

Dimension in mm

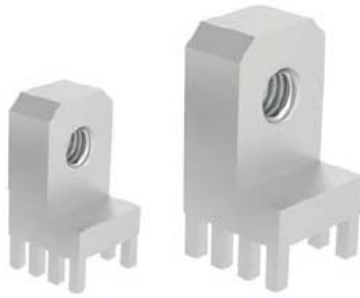

PE07 (RA-TRB)

Features

- PCB connection for fixing cable lugs
- UNC thread or customer specific modifications on demand
- As a fixing element for assembly onto housing etc.
E.g. for the connection of high current relays

特征

- 可将电缆线固定在电路板上
- 可按客户需求提供 UNC 螺纹或进行定制
- 可作为固定元件将部件固定于外壳等。
例如：可用于连接大电流继电器

Drawings

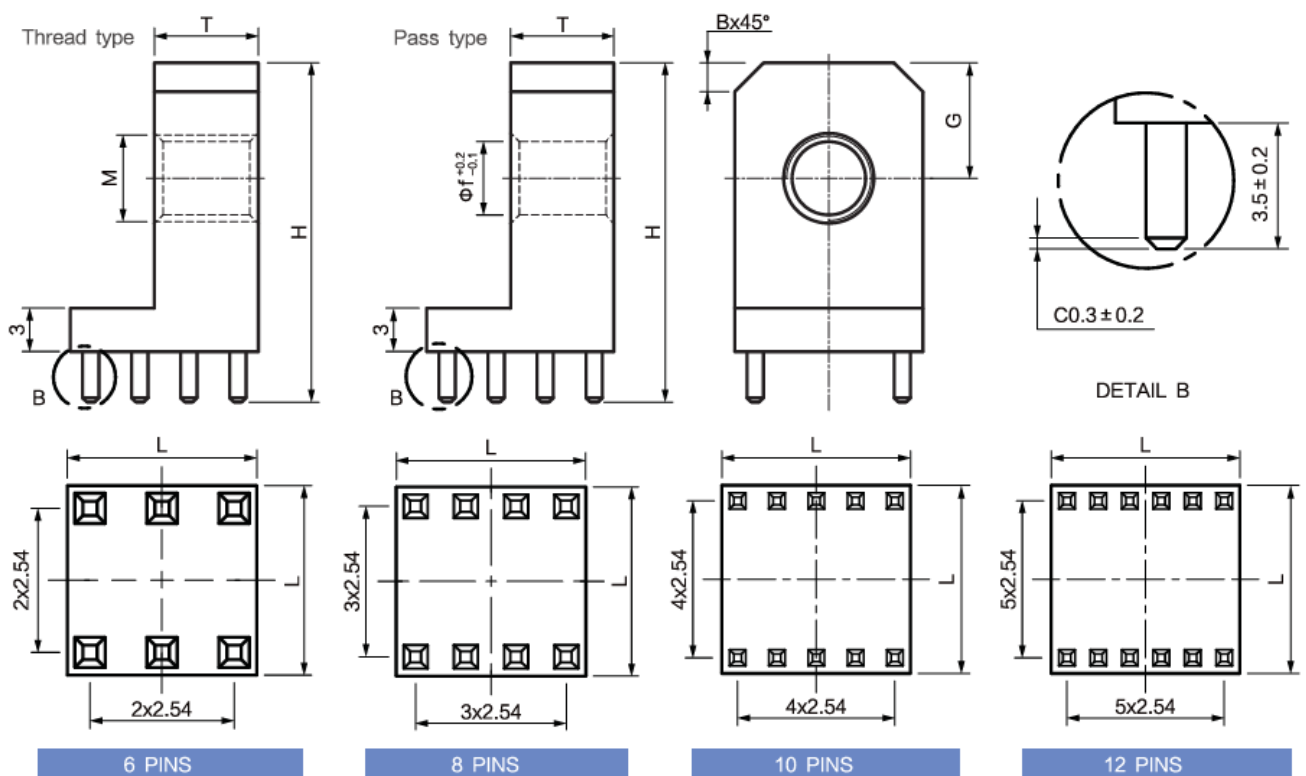

Technical Data

PROPERTIES	
Material	CuZn39Pb3
Surface	Tin
Drill Hole Diameter	1.6mm
Final Hole Diameter	1.475mm
Heat Resistance	-55 °C up to +150 °C
Retaining Force	as per IEC 352-5

Drawing No.	M/φf	B	H	T	G	L	Pins
LFPE0701	M3	1	17.5	4	5	7	6
LFPE0702	M4	1.5	17.5	5	5	9	8
LFPE0703	M5	1.5	17.5	5	5	9	8
LFPE0704	M6	2	23.5	8	8	13	10
LFPE0705	M8	2	23.5	8	8	13	10
LFPE0706	M10	2.5	28.5	10	10	16	12
LFPE0707	φ3.2	1	17.5	4	5	7	6
LFPE0708	φ4.2	1.5	17.5	5	5	9	8
LFPE0709	φ5.2	1.5	17.5	5	5	9	8
LFPE0710	φ6.2	2	23.5	8	8	13	10
LFPE0711	φ8.2	2	23.5	8	8	13	10
LFPE0712	φ10.2	2.5	28.5	10	10	16	12

Dimension in mm



PE08 (RA-FPA)

Features

- PCB connection for fixing cable lugs
- UNC thread or customer specific modifications on demand
- As a fixing element for assembly onto housing etc.
E.g. for the connection of high current relays

特征

- 可将电缆线固定在电路板上
- 可按客户需求提供 UNC 螺纹或进行定制
- 可作为固定元件将部件固定于外壳等。
例如：可用于连接大电流继电器

Drawings

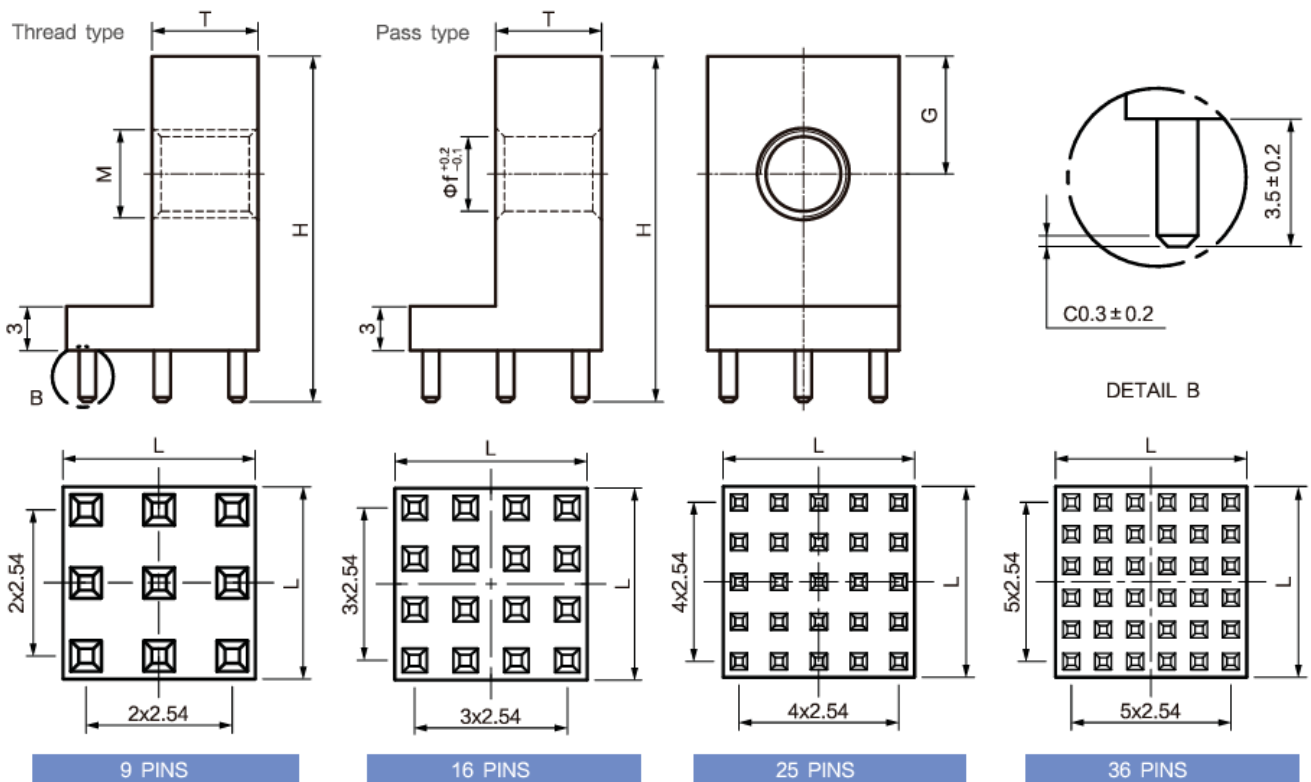

Technical Data

PROPERTIES	
Material	CuZn39Pb3
Surface	Tin
Drill Hole Diameter	1.6mm
Final Hole Diameter	1.475mm
Heat Resistance	-55 °C up to +150 °C
Retaining Force	as per IEC 352-5

Drawing No.	M/φf	H	T	G	L	Pins	I R (A)	Tightening Torque
LFPE0801	M3	17.5	4	5	7	9	130	0.5Nm
LFPE0802	M4	17.5	5	5	9	16	180	1.2Nm
LFPE0803	M5	17.5	5	5	9	16	180	2.2Nm
LFPE0804	M6	23.5	8	8	13	25	250	3.9Nm
LFPE0805	M8	23.5	8	8	13	25	250	9Nm
LFPE0806	M10	28.5	10	10	16	36	340	17Nm
LFPE0807	φ3.2	17.5	4	5	7	9	130	0.5Nm
LFPE0808	φ4.2	17.5	5	5	9	16	180	1.2Nm
LFPE0809	φ5.2	17.5	5	5	9	16	180	2.2Nm
LFPE0810	φ6.2	23.5	8	8	13	25	250	3.9Nm

Dimension in mm



PE09 (RA-FPB)

Features

- PCB connection for fixing cable lugs
- UNC thread or customer specific modifications on demand
- As a fixing element for assembly onto housing etc.
E.g. for the connection of high current relays

特征

- 可将电缆线固定在电路板上
- 可按客户需求提供 UNC 螺纹或进行定制
- 可作为固定元件将部件固定于外壳等。
例如：可用于连接大电流继电器

Drawings

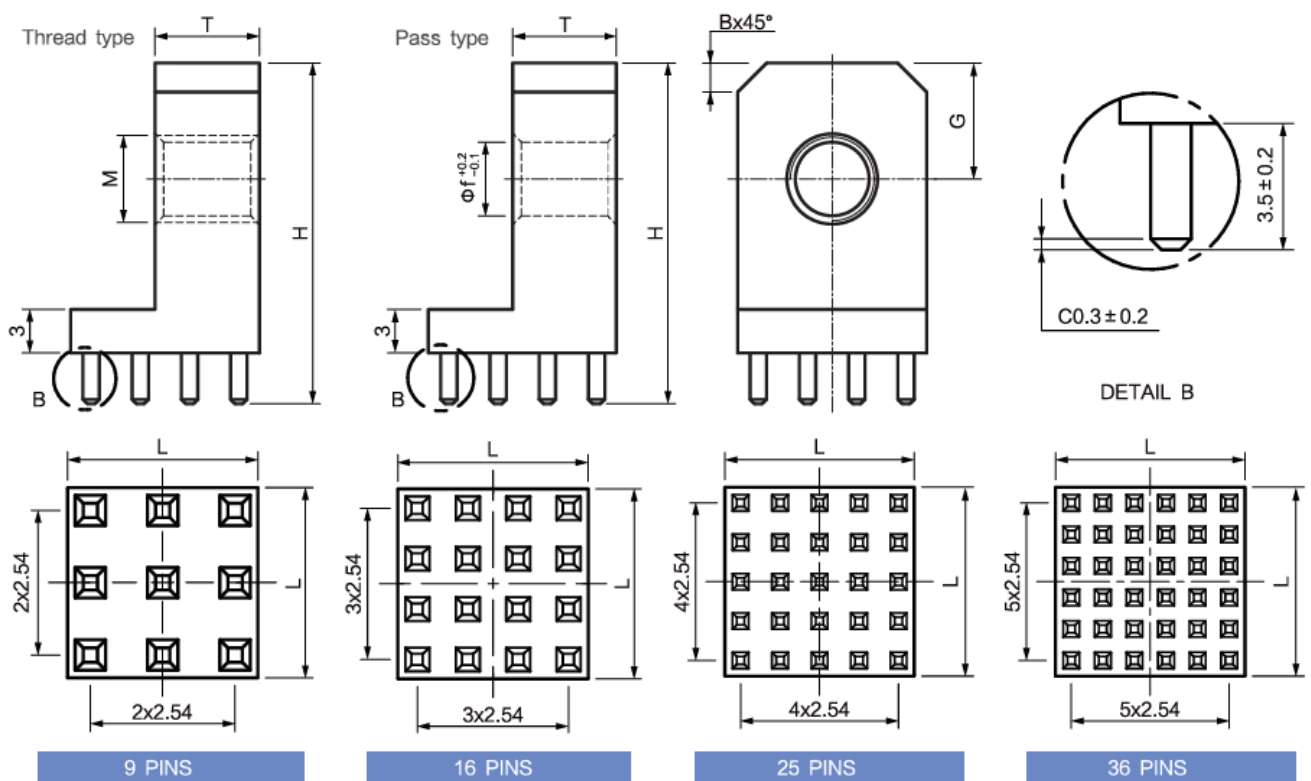

Technical Data

PROPERTIES	
Material	CuZn39Pb3
Surface	Tin
Drill Hole Diameter	1.6mm
Final Hole Diameter	1.475mm
Heat Resistance	-55 °C up to +150 °C
Retaining Force	as per IEC 352-5

Drawing No.	M/φf	B	H	T	G	L	Pins
LFPE0901	M3	1	17.5	4	5	7	9
LFPE0902	M4	1.5	17.5	5	5	9	16
LFPE0903	M5	1.5	17.5	5	5	9	16
LFPE0904	M6	2	23.5	8	8	13	25
LFPE0905	M8	2	23.5	8	8	13	25
LFPE0906	M10	2.5	28.5	10	10	16	36
LFPE0907	φ3.2	1	17.5	4	5	7	9
LFPE0908	φ4.2	1.5	17.5	5	5	9	16
LFPE0909	φ5.2	1.5	17.5	5	5	9	16
LFPE0910	φ6.2	2	23.5	8	8	13	25
LFPE0911	φ8.2	2	23.5	8	8	13	25
LFPE0912	φ10.2	2.5	28.5	5	10	16	36
LFPE0913	φ10.2	2.5	28.5	10	10	16	36

Dimension in mm

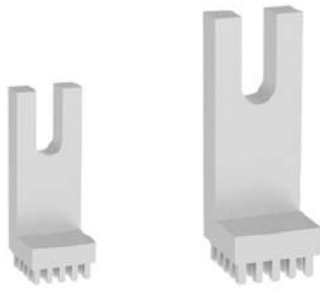

PE10 (RA-FPU)

Features

- PCB connection for fixing cable lugs
- Due to the u-profile ensures a simple proces-sing of the mounting bolt, Compensation of greater height tolerances possible.
- As a fixing element for assembly onto housing etc. E.g. for the connection of high current relays

特征

- 可将电缆线固定在电路板上
- U型设计使螺栓安装操作简单,可提供更大的高度公差
- 可作为固定元件将部件固定于外壳等。
例如: 可用于连接大电流继电器

Drawings

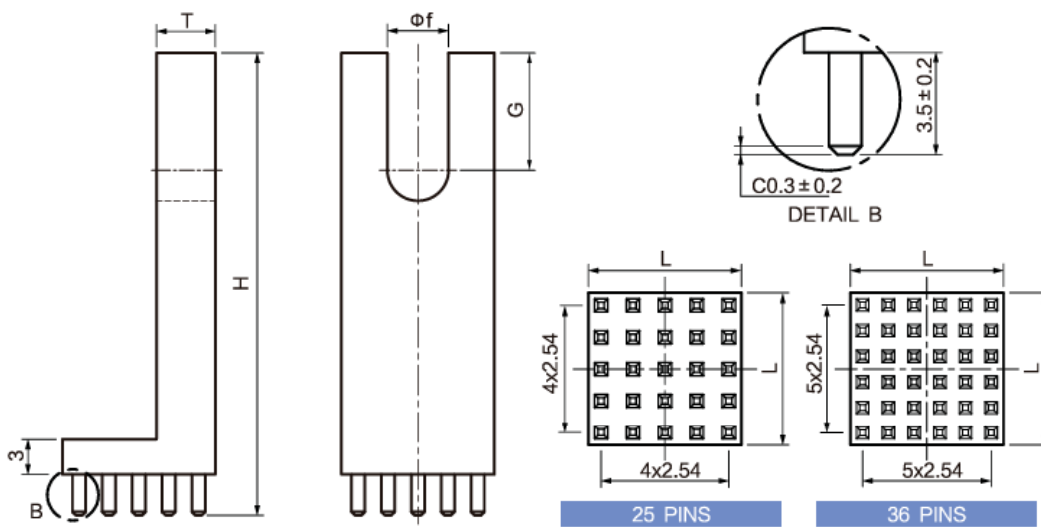

Technical Data

PROPERTIES	
Material	CuZn39Pb3
Surface	Tin
Drill Hole Diameter	1.6mm
Final Hole Diameter	1.475mm
Heat Resistance	-55 °C up to +150 °C
Retaining Force	as per IEC 352-5

Drawing No.	Φf	H	T	G	L	Pins
LFPE1001	Φ5.2	39.5	5	10	13	25
LFPE1002	Φ8.2	42.5	5	10	16	36
LFPE1003	Φ10.2	44.5	5	13	16	36

Dimension in mm

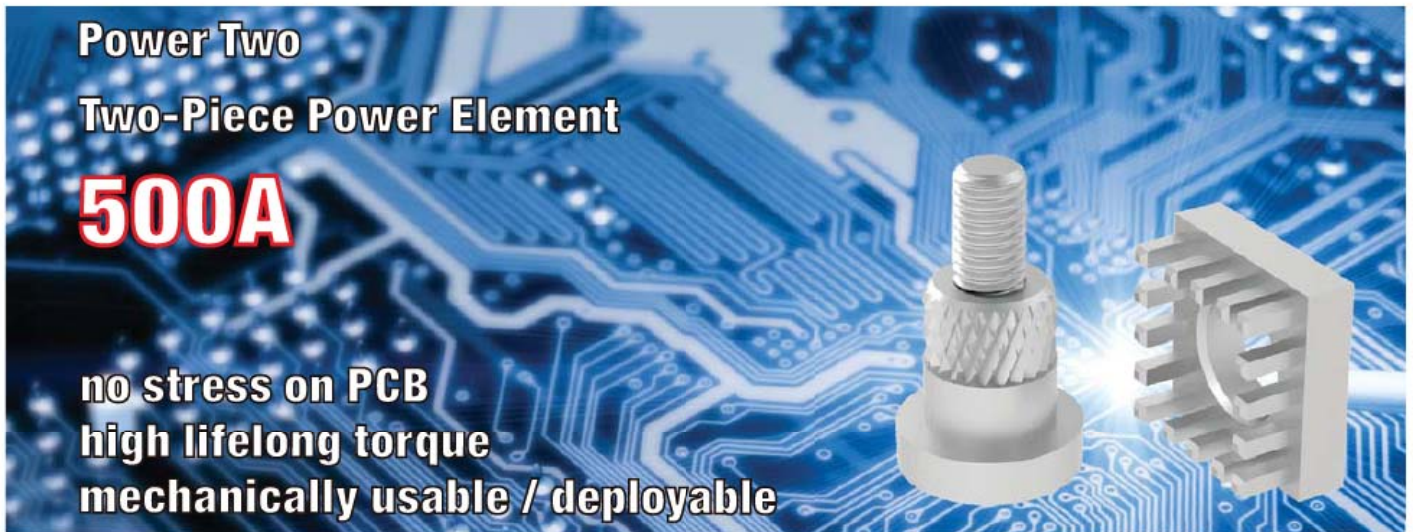

Two-piece Power Elements are a solution for through screw technologies on circuit boards. These high current terminal blocks and spacers enable a durable and reliable connection and mounting on the PCB without stressing it. Depending on the pin arrangement and the layout, currents of up to 500A are possible. The assembly method allows individual adaptations regarding design and dimensions. That is the reason why Power Elements perfectly qualify as connecting elements for fuses, IGBTs, switches and cables and the circuit board or for board-to-board connections.

Application Possibilities

- Board-to-board stackable
- Wire-to-board screw connection of ring terminals
- Electro mechanics, through screw technology, spacers
- Retainers / fastenings of switches, fuses, IGBTs
- Any combination of all these and much more

Processing

In-sail PowerTwo Power Elements are pressed in into the circuit board. Soldering is not necessary. Therefore, the PCBs are not exposed to temperature stress. This processing step easily blends in to the processing chain and is highly cost efficient. With the aid of the corresponding Press Fit tools, several Power Elements can be Press Fit simultaneously.

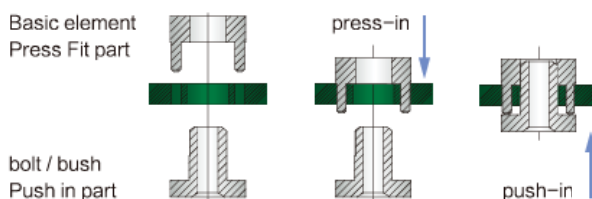

For assembling prototypes, no special equipment is needed for pressing in, a simple toggle press is sufficient

1. The circuit board needs support during the pressing procedure
2. The pressing force must be executed in a 90° angle to the circuit board
3. After the pressing process the pins should stand out of the drilled hole (ca. 0.2 – 0.5mm)

Technical Data	
Current carrying capacity per pin at 20 °C	~ 15A
Current carrying capacity per pin at 85 °C	~ 10A
Material	CuZn39Pb3
Surfaces	Tin-plated (standard)
	further surfaces such as nickel, silver, nickel / gold and others on demand

Dimensions	
Length x width	from 9 x 9 to 22 x 22 mm
Height	from 3mm individually
Height above PCB	from 3mm individually
Pin length	up to 7.5mm (standard of 3.5mm)
Pin diagonal	1.6mm standard
	others on demand

Circuit Board	
Base material	FR4 (EPGC202)
PCB thickness	from 1.5mm
Drilling diameter	1.60 ± 0.025mm
Final diameter HAL surface	1.45 ± 0.05mm
chemical surface	1.475 ± 0.05mm
Copper in hole thickness	min. 25µm, max. 80µm

Processing Parameters	
Press-in force	min. 40N per Pin max. 250N per Pin
Retention force	60 – 80 % of the press-in force
Press-in speed	100 – 250mm /min

4. Plated through holes of the circuit board must be executed according to our indications
5. PowerTwo high current terminal blocks and spacers are manufactured for pressing, soldering is not intended.

Circuit Board Design

Via Specification For Chemical Surfaces

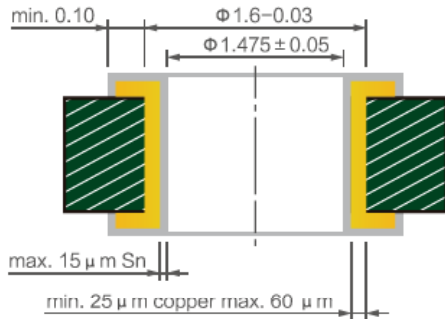

Via Specification For HAL (Hot Air Solder Leveling)

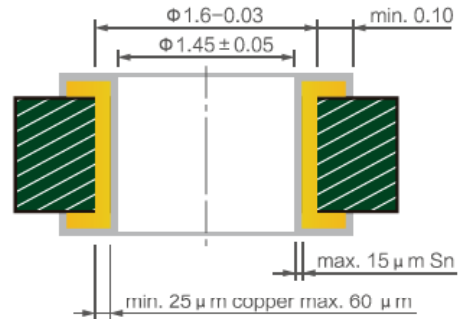

Torques

The torques indicated in the table are based on DIN 267 part 25. Different material combinations or different thread lengths of the connectors are not regarded here.

Torques for Brass

Thread	M2.5	M3	M4	M5	M6	M8	M10
(Nm)	0.3	0.5	1.2	2.2	3.9	9.0	17.0

Current Carrying Capacity

The current carrying capacity of a Press Fit connection needs to be seen in the context of the overall system. The Press Fit zone has a very low electrical contact resistance of 100 – 200 Ω . The limiting factor therefore usually lies in the circuit board layout or in the connection of a feed line.

Reference values for a pre-dimensioning can be found under Technical Data on page 22.

Derating Curve

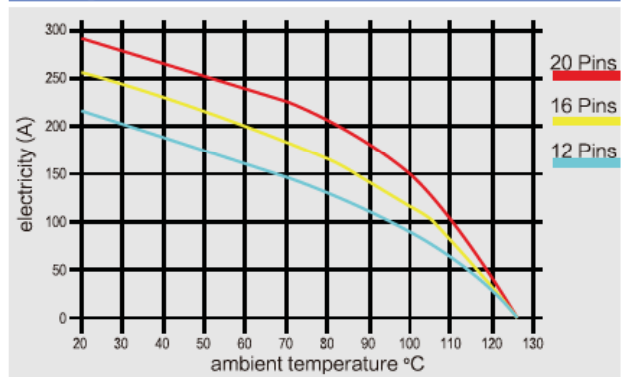

Overview of PowerTwo products

Customer Specific	basic element pins two-rowed	basic element pins circumferential	socket female thread	socket through hole	bolt male thread
	Pins		Thread or Hole		
	8, 10, 12	12, 16, 20	M3 – M10	Φ3.2 – Φ10.2	M3 – M10

All threads are available in UNC

Supplies

Based on your different requirements, we also provide some relevant products at the back of this brochure. For further inquiries, please contact our sales representative.

PE11 (TP-GET)

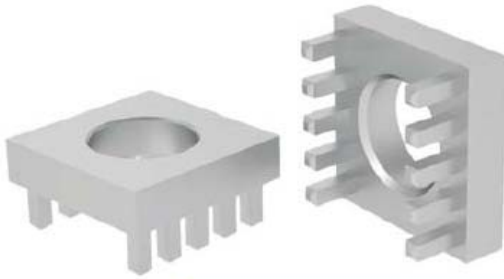

Features

- Two-Part, Base-Part, Two-Row-Pin population, PCB connection for fixing cable lugs
- Fixing of large heavy components (e.g. battery disconnection switch)
- Protecting PCB from mechanical stress

特征

- 双部件，底座，双排式，可将电缆线固定在电路板上
- 用于固定大型重型部件。例如：电池断路开关
- 防止机械应力对电路板的损害

Drawings

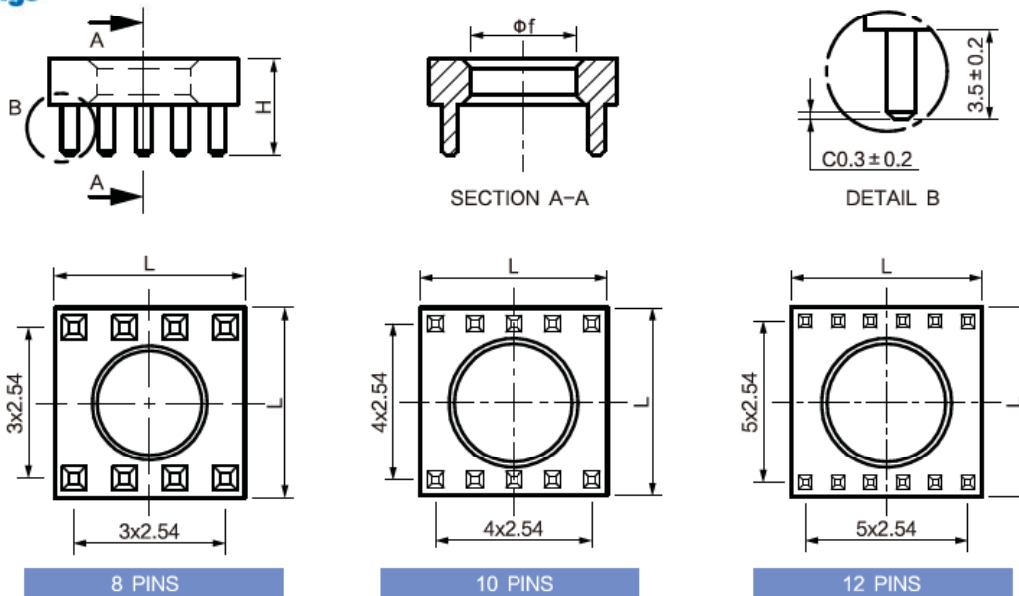

Technical Data

PROPERTIES	
Material	CuZn39Pb3
Surface	Tin
Drill Hole Diameter	1.6mm
Final Hole Diameter	1.475mm
Heat Resistance	-55 °C up to +150 °C
Retaining Force	as per IEC 352-5

Drawing No.	Φf	H	L	Pins	I R (A)	Tightening Torque
LFPE1101	Φ5.5	6.6	9	8	160	2.2Nm
LFPE1102	Φ7.3	6.6	13	10	240	3.9Nm
LFPE1103	Φ9.8	6.6	16	12	320	17Nm
LFPE1104	Φ10.5	6.6	16	12	320	17Nm

Dimension in mm

PE12 (TP-GEC)

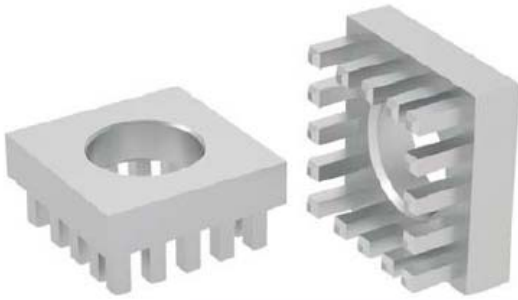

Features

- Two-Part, Base-Part, Circular-Pin population, PCB connection for fixing cable lugs
- Fixing of large heavy components (e.g. battery disconnection switch)
- Protecting PCB from mechanical stress

特征

- 双部件，底座，环绕型，可将电缆线固定在电路板上
- 用于固定大型重型部件。例如：电池断路开关
- 防止机械应力对电路板的损害

Drawings

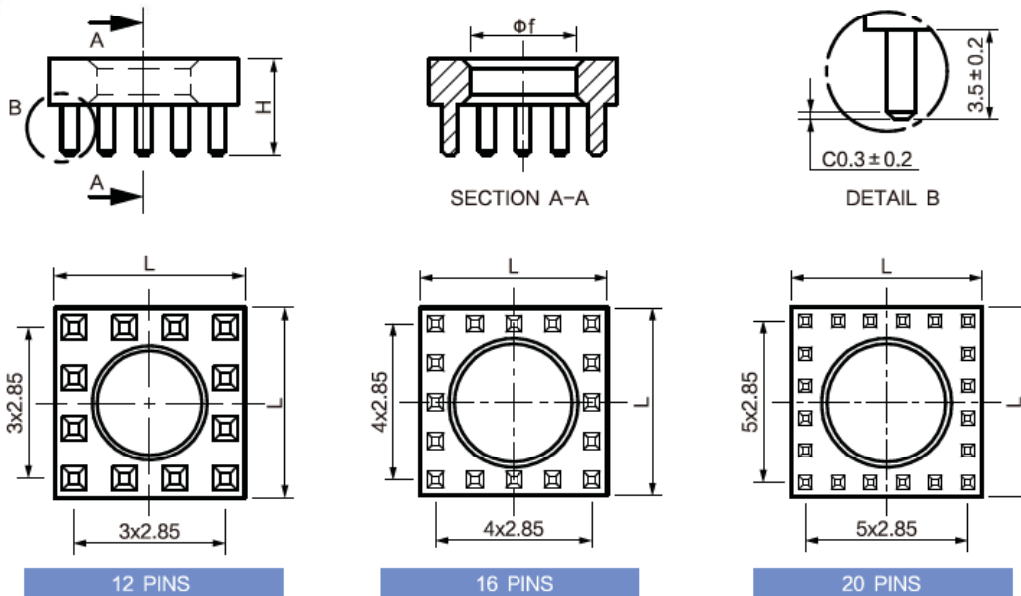

Technical Data

PROPERTIES	
Material	CuZn39Pb3
Surface	Tin
Drill Hole Diameter	1.6mm
Final Hole Diameter	1.475mm
Heat Resistance	-55 °C up to +150 °C
Retaining Force	as per IEC 352-5
Massive Pressfit Zone Pitch	2.85mm

Drawing No.	ϕf	H	L	Pins
LFPE1201	$\phi 6.2$	6.6	10	12
LFPE1202	$\phi 7.3$	6.6	13	16
LFPE1203	$\phi 12$	6.6	16	20

Dimension in mm

PE13 (TP-SERI)



Features

- Two-Part, Female Thread. The cable can be fixed on the PCB board with the Base-Part.
- Fixing of large heavy components
- UNC thread or customer specific modifications on demand

特征

- 双部件，插座，圆头内螺纹。与底座配合使用，可将电缆线固定在电路板上。
- 用于固定大型重型部件
- 可按客户需求提供 UNC 螺纹或进行定制

Drawings



Diamond knurling

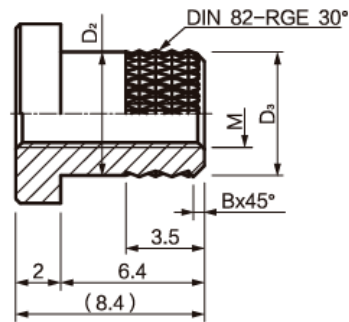

Technical Data

PROPERTIES	
Material	CuZn39Pb3
Surface	Tin
Rate Current	up to 300A
Heat Resistance	-55 °C up to +150 °C

Diamond knurling

Drawing No.	M	D	$D_2 - 0.2$	$D_3 \pm 0.05$	B	Used Base Plate
LFPE1301	M3	8	5.65	5.65	0.5	LFPE1101
LFPE1302	M5	12	7.45	7.45	0.5	LFPE1201
LFPE1303	M6	12	7.4	7.4	0.3	LFPE1102 LFPE1202
LFPE1304	M8	15	9.95	9.95	0.5	LFPE1103
LFPE1305	M8	15	10.65	10.65	0.5	LFPE1104
LFPE1306	M4	8	5.65	5.65	0.5	LFPE1101

Dimension in mm

PE14 (TP-SESE)



Features

- Two-Part, Female Thread. The cable can be fixed on the PCB board with the Base-Part.
- Fixing of large heavy components
- UNC thread or customer specific modifications on demand

特征

- 双部件，插座，方头内螺纹。与底座配合使用，可将电缆线固定在电路板上。
- 用于固定大型重型部件
- 可按客户需求提供 UNC 螺纹或进行定制

Drawings

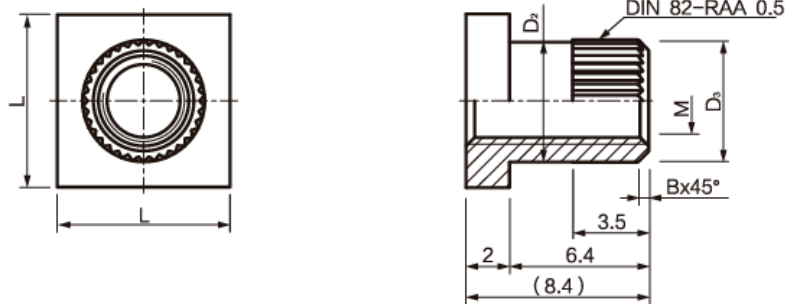

Technical Data

PROPERTIES	
Material	CuZn39Pb3
Surface	Tin
Rate Current	up to 300A
Heat Resistance	-55 °C up to +150 °C

Drawing No.	M	L	D ₂ -0.2	D ₃ ±0.05	B	Used Base Plate
LFPE1401	M3	9	5.65	5.65	0.5	LFPE1101
LFPE1402	M3	10	6.35	6.35	0.5	LFPE1201
LFPE1403	M4	9	5.65	5.65	0.3	LFPE1101
LFPE1404	M4	10	6.35	6.35	0.5	LFPE1201
LFPE1405	M4	13	7.45	7.45	0.5	LFPE1102 LFPE1202
LFPE1406	M5	10	6.35	6.35	0.3	LFPE1201
LFPE1407	M5	13	7.45	7.45	0.5	LFPE1102 LFPE1202
LFPE1408	M6	13	7.45	7.45	0.3	LFPE1102 LFPE1202
LFPE1409	M8	16	10	10	0.5	LFPE1103
LFPE1410	M8	16	10.65	10.65	0.5	LFPE1104
LFPE1411	M8	16	12.15	12.15	0.5	LFPE1203
LFPE1412	M10	16	12.15	12.15	0.5	LFPE1203

Dimension in mm

PE15 (TP-SERH)

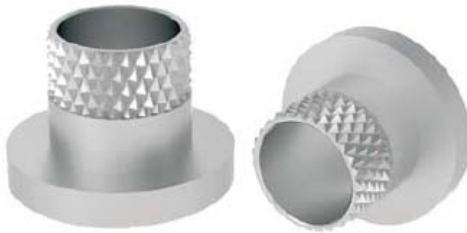

Features

- Two-Part, Female Through-Hole. The cable can be fixed on the PCB board with the Base-Part.
- Fixing of large heavy components

特征

- 双部件，插座，圆头光孔。与底座配合，可将电缆线、保险丝固定在电路板上
- 用于固定大型重型部件

Drawings

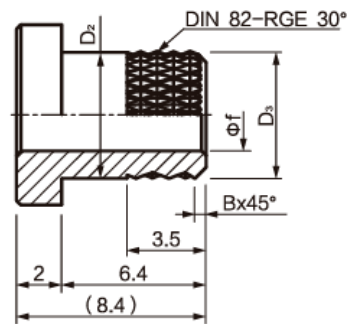

Technical Data

PROPERTIES	
Material	CuZn39Pb3
Surface	Tin
Rate Current	up to 300A
Heat Resistance	-55 °C up to +150 °C

Drawing No.	Φf	D	D ₂ -0.2	D ₃ ± 0.05	B	Used Base Plate
LFPE1501	Φ3.2	8	5.65	5.65	0.5	LFPE1101
LFPE1502	Φ4.2	8	5.65	5.65	0.3	LFPE1101
LFPE1503	Φ5.2	12	7.45	7.45	0.5	LFPE1102 LFPE1202
LFPE1504	Φ6.2	12	7.45	7.45	0.3	LFPE1102 LFPE1202
LFPE1505	Φ8.2	15	9.95	9.95	0.5	LFPE1103
LFPE1506	Φ8.2	15	10.65	10.65	0.5	LFPE1104

Dimension in mm

PE16 (TP-SESH)

Features

- Two-Part, Female Through-Hole. The cable can be fixed on the PCB board with the Base-Part.
- Fixing of large heavy components

特征

- 双部件，插座，方头光孔。与底座配合，可将电缆线、保险丝固定在电路板上
- 用于固定大型重型部件



Drawings

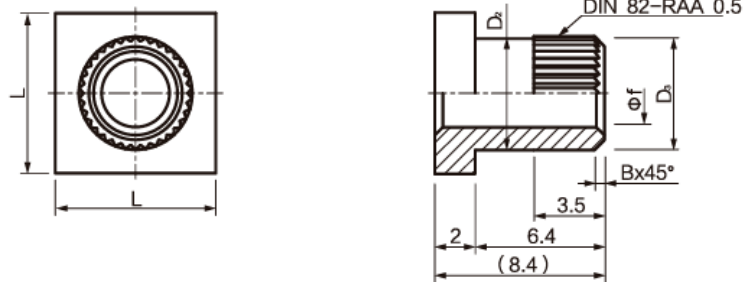

Technical Data

PROPERTIES	
Material	CuZn39Pb3
Surface	Tin
Rate Current	up to 300A
Heat Resistance	-55 °C up to +150 °C

Drawing No.	Φ f	L	D ₂ -0.2	D ₃ ±0.05	B	Used Base Plate
LFPE1601	Φ3.2	9	5.65	5.65	0.5	LFPE1101
LFPE1602	Φ3.2	10	6.35	6.35	0.5	LFPE1201
LFPE1603	Φ4.2	9	5.65	5.65	0.3	LFPE1101
LFPE1604	Φ4.2	10	6.35	6.35	0.5	LFPE1201
LFPE1605	Φ4.2	13	7.45	7.45	0.5	LFPE1202 LFPE1102
LFPE1606	Φ5.2	10	6.35	6.35	0.3	LFPE1201
LFPE1607	Φ5.2	13	7.45	7.45	0.5	LFPE1202 LFPE1102
LFPE1608	Φ6.2	13	7.45	7.45	0.3	LFPE1202 LFPE1102
LFPE1609	Φ6.2	16	10.65	10.65	0.5	LFPE1104
LFPE1610	Φ8.2	16	10	10	0.5	LFPE1103
LFPE1611	Φ8.2	16	10.65	10.65	0.5	LFPE1104
LFPE1612	Φ8.2	16	12.15	12.15	0.5	LFPE1203
LFPE1613	Φ10.2	16	12.15	12.15	0.5	LFPE1203

Dimension in mm



PE17 (TP-SERE)

Features

- Two-Part, Male Thread. The cable can be fixed on the PCB board with the Base-Part
- Fixing of large heavy components
- UNC thread or customer specific modifications on demand

特征

- 双部件，插针，圆头外螺纹。与底座配合使用，可将电缆线、保险丝固定在电路板上
- 用于固定大型重型部件
- 可按客户需求提供 UNC 螺纹或进行定制

Drawings

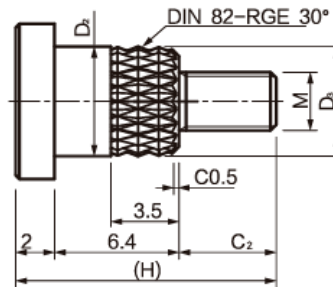

Technical Data

PROPERTIES	
Material	CuZn39Pb3
Surface	Tin
Rate Current	up to 300A
Heat Resistance	-55 °C up to +150 °C

Drawing No.	M	H	C ₂	D	D ₂ -0.2	D ₃ ± 0.05	Used Base Plate
LFPE1701	M3	13.4	5	8	5.65	5.65	LFPE1101
LFPE1702	M4	14.4	6	8	5.65	5.65	LFPE1101
LFPE1703	M5	16.4	8	12	7.45	7.45	LFPE1102 LFPE1202
LFPE1704	M6	18.4	10	12	7.45	7.45	LFPE1102 LFPE1202
LFPE1705	M8	21.4	13	15	9.95	9.95	LFPE1103
LFPE1706	M8	21.4	13	15	10.65	10.65	LFPE1104

Dimension in mm



PE18 (TP-SESI)

Features

- Two-Part, Male Thread. The cable can be fixed on the PCB board with the Base-Part
- Fixing of large heavy components
- UNC thread or customer specific modifications on demand

特征

- 双部件，插针，方头外螺纹。与底座配合使用，可将电缆线、保险丝固定在电路板上
- 用于固定大型重型部件
- 可按客户需求提供 UNC 螺纹或进行定制

Drawings

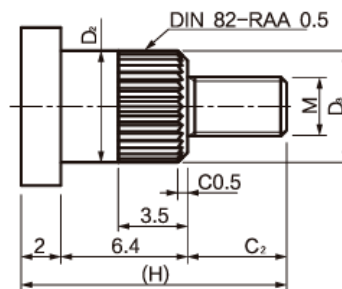
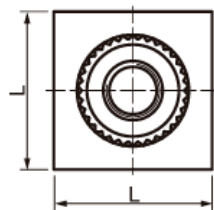

Technical Data

PROPERTIES	
Material	CuZn39Pb3
Surface	Tin
Rate Current	up to 300A
Heat Resistance	-55 °C up to +150 °C

Drawing No.	M	H	L	C ₂	D ₂ -0.2	D ₃ ± 0.05	Used Base Plate
LFPE1801	M3	13.4	9	5	5.6	5.6	LFPE1101
LFPE1802	M3	14.4	10	6	6.35	6.35	LFPE1201
LFPE1803	M4	14.4	9	6	5.6	5.6	LFPE1101
LFPE1804	M4	14.4	10	6	6.35	6.35	LFPE1201
LFPE1805	M4	16.4	13	8	7.45	7.45	LFPE1202 LFPE1102
LFPE1806	M5	16.4	13	8	7.45	7.45	LFPE1202 LFPE1102
LFPE1807	M5	17.4	10	9	6.35	6.35	LFPE1201
LFPE1808	M6	18.4	13	10	7.45	7.45	LFPE1202 LFPE1102
LFPE1809	M8	21.4	16	13	10	10	LFPE1103
LFPE1810	M8	21.4	16	13	10.65	10.65	LFPE1104
LFPE1811	M8	21.4	16	13	12.15	12.15	LFPE1203
LFPE1812	M10	21.4	16	13	12.15	12.15	LFPE1203

Dimension in mm

THR (Through-hole Reflow)

Power Element

50A 85A

reliable
Automatic installation
high mechanical perfor

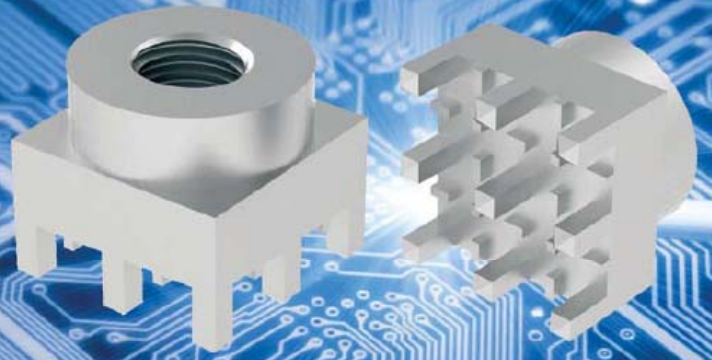

The miniaturization of electronic components has elevated the requirements of our products. In the PCB industry, low power components increased the demand and the requirements of automation. After years of research and development, we developed miniaturization and low resistance THR products series. The product can meet the requirements of either manual or automatic installation for the line to board connection or plate to board 90 degree connection.

THR (Through-hole Reflow, also called pin in paste-PIP) technology is the technology of combining high mechanical strength and automated processing. For the large number of PCB processing board

application of perforated elements, this technology can be replaced of wave-soldering in SMT process.

These products can be handled like SMD products because the two products are using the same principle. At the same time, the clear benefits of THR products is that it has better mechanical bonding strength can be achieved with vias.

THR series products have 4, 8, 9, three kinds of pin configuration, the maximum current support up to 85A. By integrating the design, the soldering are more stable and easier to control within the production tolerances. The through hole reflow welding has lower resistance, less current loss, improve work efficiency, reduce energy consumption compared to microwave soldering.

The THR product series is a better choice for environmental friendliness that require high mechanical connection strength and low energy consumption.

Product installation flow chart

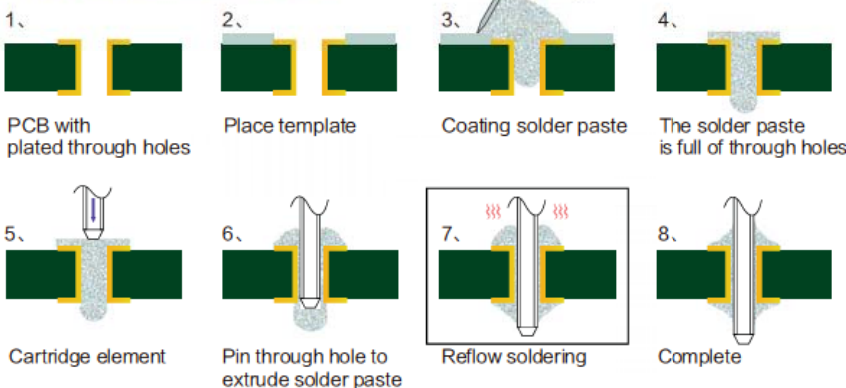

Product installation drawing

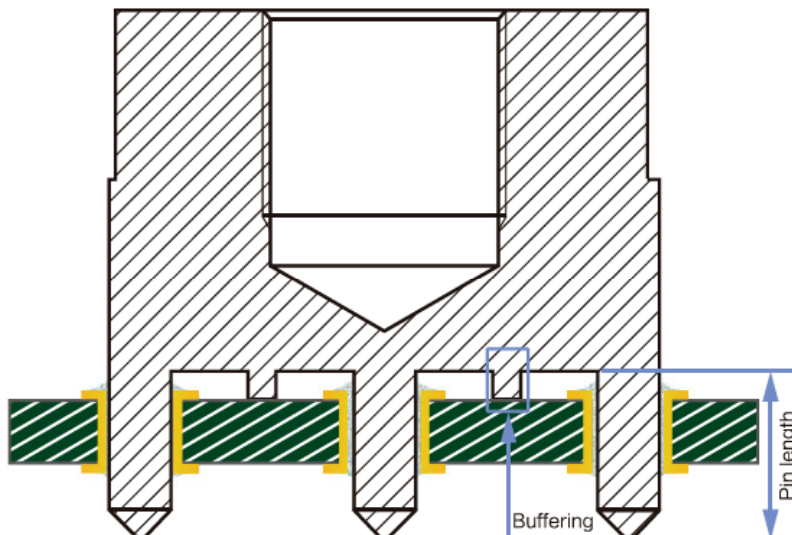

The Advantages of Through hole reflow soldering

1. Through hole reflow soldering provides better quality low PPM rate (PPM rate of defects) which can be less than 20%.
2. Soldering tinless defects, and the rework rate is very low.
3. The layout design of the PCB has less consideration factors compared to the wave soldering process.
4. The process is simple and the equipment is easy to operate.
5. The hole reflow soldering equipment covers less area, because of its printing presses and reflow furnace are smaller, so only a small area required.
6. Free of Tin slag.
7. The machine is fully enclosed, clean, and odorless in the production workshop.
8. The reflow soldering equipment management and maintenance is easy.
9. The printing template is adopted in the printing process, and each welding point and the amount of printed paste can be adjusted according to the requirements.
10. During the reflow, the use of special templates, the temperature of each welding point can be adjusted according to the need.

PE19 (THR-IHT)

Features

- Solderable high current Wire-to-Board connections with a focus on automated assembly
- PCB connection for fixing cable lugs
- Cable or PCB angle assembly

特征

- 可焊接高电流线对板连接，重点是可以自动化装配
- 可将电缆线固定在电路板上
- 电缆或 PCB 有角度装配

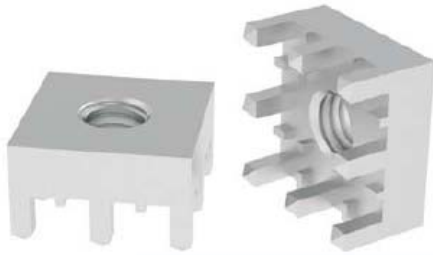

Drawings

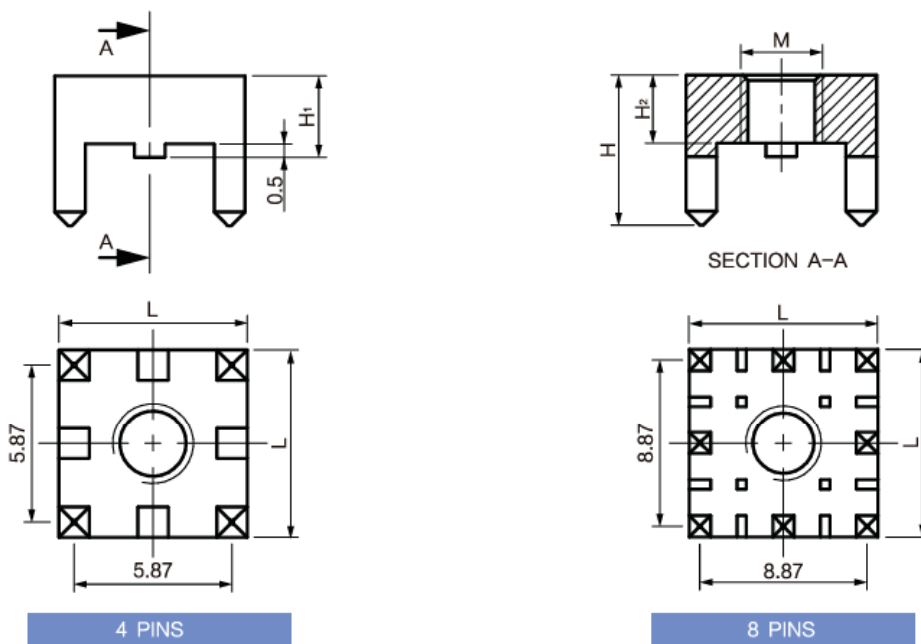

Technical Data

PROPERTIES	
Material	Brass
Surface	Tin
Solder Cream Thickness	150 μm
Heat Resistance	-55 °C up to +150 °C
Packaging	Bulk; Tape and Reel

Drawing No.	M	H	H ₁	H ₂	L	Pins	I R (A)	Tightening Torque
LFPE1901	M3	5.5	3	2.5	7	4	50	0.5Nm
LFPE1902	M4	5.5	3	2.5	7	4	50	1.2Nm
LFPE1903	M4	6	3.5	3	10	8	85	1.2Nm
LFPE1904	M5	6.5	4	3.5	10	8	85	2.2Nm

Dimension in mm

PE20 (THR-IBT)

Features

- Solderable high current Wire-to-Board connections with a focus on automated assembly
- PCB connection for fixing cable lugs
- Cable or PCB angle assembly

特征

- 可焊接高电流线对板连接，重点是可以自动化装配
- 可将电缆线固定在电路板上
- 电缆或 PCB 有角度装配

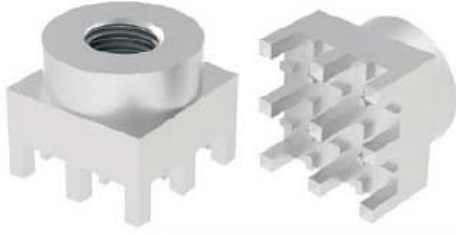

Drawings

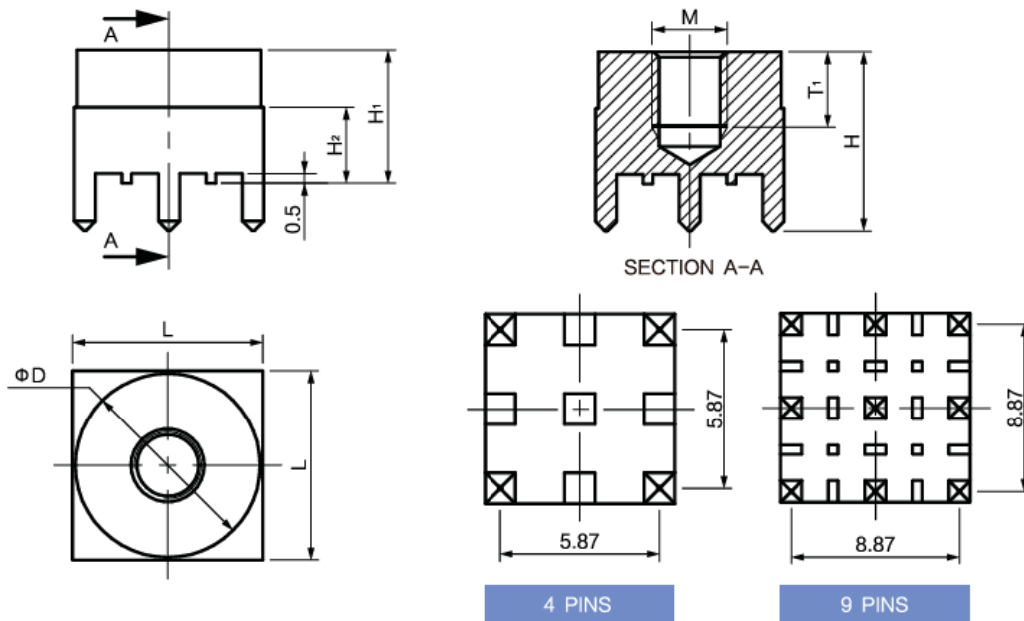

Technical Data

PROPERTIES	
Material	Brass
Surface	Tin
Solder Cream Thickness	150 μm
Heat Resistance	-55 °C up to +150 °C
Packaging	Bulk; Tape and Reel

Drawing No.	M	T ₁	H	H ₁	H ₂	ΦD	L	Pins	I R (A)	Tightening Torque
LFPE2001	M3	3.5	8.5	6	4	Φ6.6	7	4	50	0.5Nm
LFPE2002	M4	4	9	6.5	4	Φ6.6	7	4	50	1.2Nm
LFPE2003	M4	4	9.5	7	4	Φ9.7	10	9	85	1.2Nm
LFPE2004	M5	4	9.5	7	4	Φ9.7	10	9	85	2.2Nm

Dimension in mm

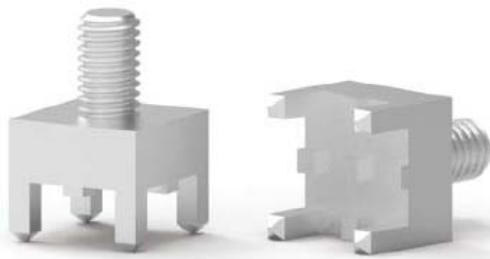

PE21 (THR-EH)

Features

- Solderable high current Wire-to-Board connections with a focus on automated assembly
- PCB connection for fixing cable lugs
- Cable or PCB angle assembly

特征

- 可焊接高电流线对板连接，重点是可以自动化装配
- 可将电缆线固定在电路板上
- 电缆或 PCB 有角度装配

Drawings

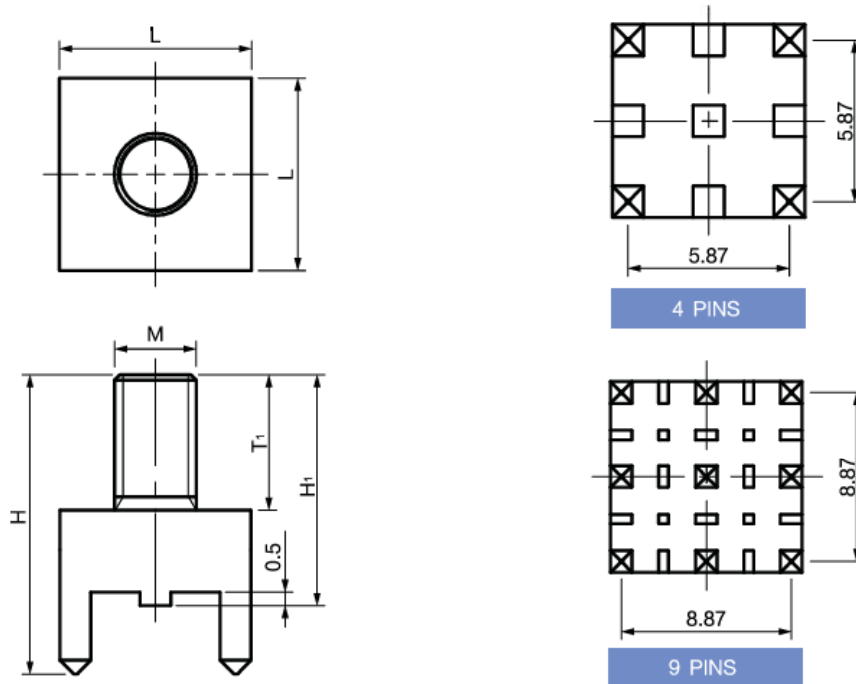

Technical Data

PROPERTIES	
Material	Brass
Surface	Tin
Solder Cream Thickness	150 μm
Heat Resistance	-55 °C up to +150 °C
Packaging	Bulk; Tape and Reel

Drawing No.	M	H	H ₁	T ₁	L	Pins	I R (A)	Tightening Torque
LFPE2101	M3	11	8.5	5	7	4	50	0.5Nm
LFPE2102	M4	11	8.5	5	7	4	50	1.2Nm
LFPE2103	M4	11	8.5	5	10	9	85	1.2Nm
LFPE2104	M5	13	10.5	7	7	4	50	2.2Nm
LFPE2105	M5	13	10.5	7	10	9	85	2.2Nm

Dimension in mm

THR System of Pin and mounting hole layout

Research and development of THR products for PCB layout and production has specific requirements, thus, we provide a standard PCB product layout and design specifications of solder paste bushing.

For customized products, the layout design for the PCB and the solder bushing need to be correct in order to achieve the optimum performance of the products.

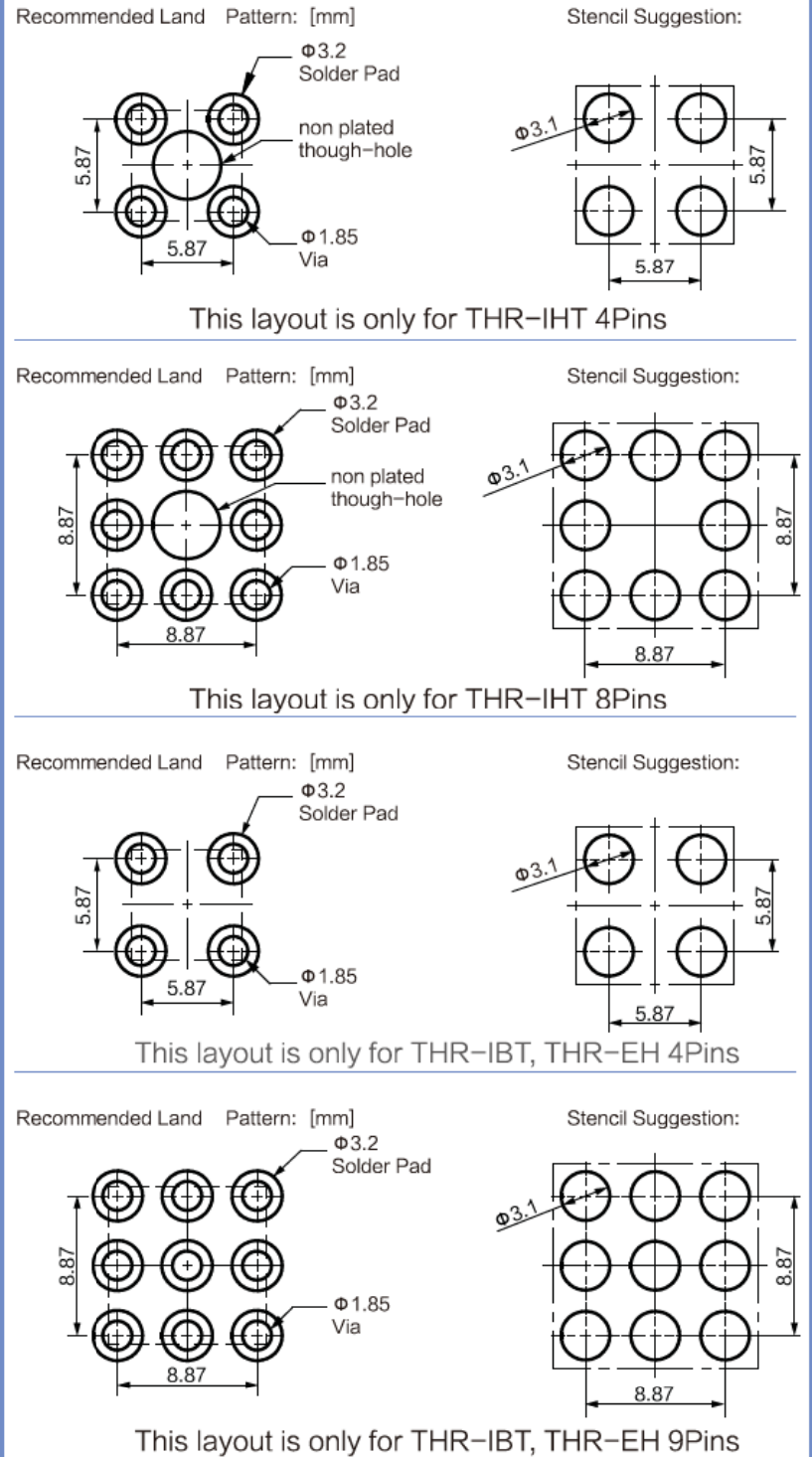

PE22 (SMD-ET)



Features

- For soldering in SMT, it is suitable for fully automated assembly.
- PCB connection for fixing cable lugs
- UNC thread or customer specific modifications on demand

特征

- 表面贴装焊接，适用于全自动组装
- 可将电缆线固定在电路板上
- 可按客户需求提供 UNC 螺纹或进行定制

Drawings

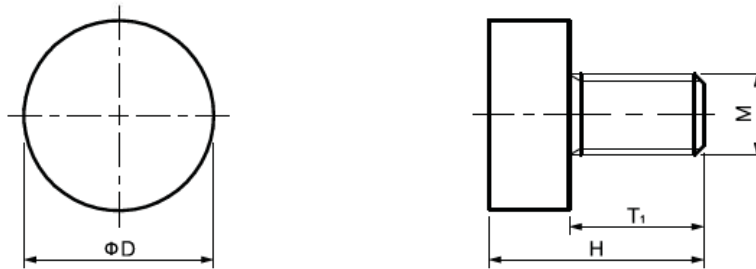

Technical Data

PROPERTIES	
Material	Brass
Surface	Tin
Solder Cream Thickness	150 μm
Heat Resistance	-55 °C up to +150 °C
Packaging	Bulk; Tape and Reel

Drawing No.	M	H	T ₁	ΦD
LFPE2201	M3	8	5	Φ7
LFPE2202	M4	8	5	Φ7
LFPE2203	M4	9.5	6	Φ9
LFPE2204	M5	12.5	8	Φ9
LFPE2205	M6	15.5	10	Φ13
LFPE2206	M8	20.5	13	Φ13
LFPE2207	M10	24	16	Φ16

Dimension in mm

PE23 (SMD-ETP)



Features

- For soldering in SMT, it is suitable for fully automated assembly.
- PCB connection for fixing cable lugs
- UNC thread or customer specific modifications on demand

特征

- 表面贴装焊接，适用于全自动组装
- 可将电缆线固定在电路板上
- 可按客户需求提供 UNC 螺纹或进行定制

Drawings

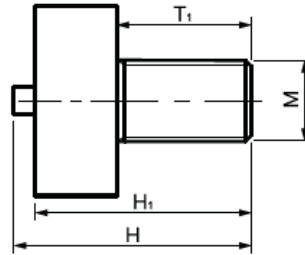
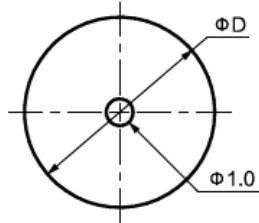

Technical Data

PROPERTIES	
Material	Brass
Surface	Tin
Solder Cream Thickness	150 μm
Heat Resistance	-55 °C up to +150 °C
Packaging	Bulk; Tape and Reel

Drawing No.	M	H	H ₁	T ₁	ΦD
LFPE2301	M3	8.8	8	5	Φ7
LFPE2302	M4	8.8	8	5	Φ7
LFPE2303	M4	10.5	9.5	6	Φ9
LFPE2304	M5	13.5	12.5	8	Φ9
LFPE2305	M6	16.5	15.5	10	Φ13
LFPE2306	M8	21.5	20.5	13	Φ13
LFPE2307	M10	25	24	16	Φ16

Dimension in mm

PE24 (SMD-IBT)



Features

- For soldering in SMT, it is suitable for fully automated assembly.
- PCB connection for fixing cable lugs
- UNC thread or customer specific modifications on demand

特征

- 表面贴装焊接，适用于全自动组装
- 可将电缆线固定在电路板上
- 可按客户需求提供 UNC 螺纹或进行定制

Drawings

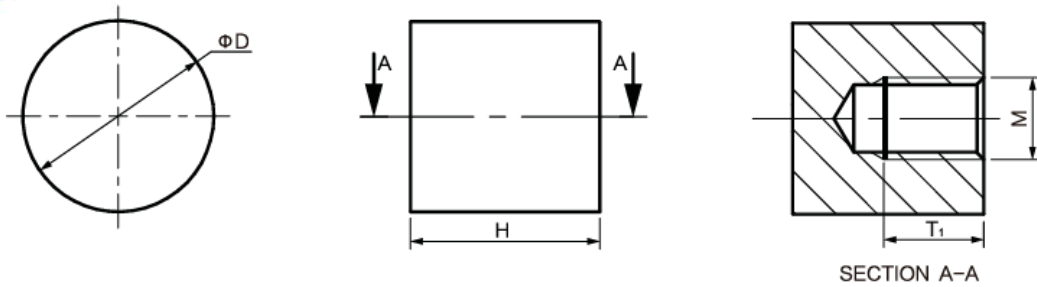

Technical Data

PROPERTIES	
Material	Brass
Surface	Tin
Solder Cream Thickness	150 μ m
Heat Resistance	-55 °C up to +150 °C
Packaging	Bulk; Tape and Reel

Drawing No.	M	H	T ₁	ϕD	I R (A)	Tightening Torque
LFPE2401	M3	7	4	$\phi 7$	50	0.5Nm
LFPE2402	M4	7	4	$\phi 7$	50	1.2Nm
LFPE2403	M5	7	4	$\phi 9$	70	2.2Nm

Dimension in mm

PE25 (SMD-IBTP)



Features

- For soldering in SMT, it is suitable for fully automated assembly.
- PCB connection for fixing cable lugs
- UNC thread or customer specific modifications on demand

特征

- 表面贴装焊接，适用于全自动组装
- 可将电缆线固定在电路板上
- 可按客户需求提供 UNC 螺纹或进行定制

Drawings

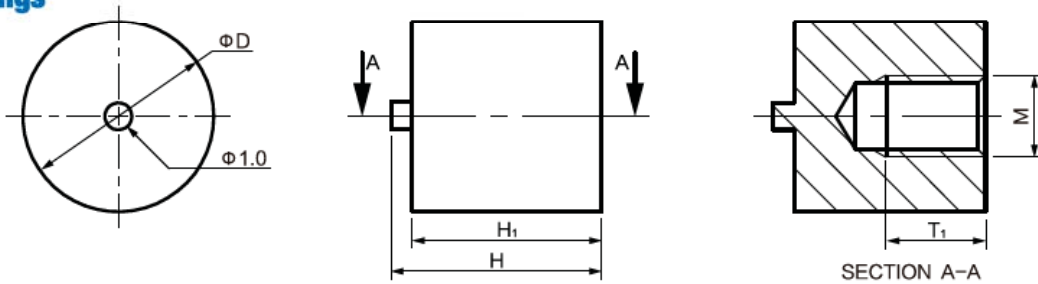

Technical Data

PROPERTIES	
Material	Brass
Surface	Tin
Solder Cream Thickness	150 μ m
Heat Resistance	-55 °C up to +150 °C
Packaging	Bulk; Tape and Reel

Drawing No.	M	H	H ₁	T ₁	ϕD	I R (A)	Tightening Torque
LFPE2501	M3	7.8	7	4	$\phi 7$	50	0.5Nm
LFPE2502	M4	7.8	7	4	$\phi 7$	50	1.2Nm
LFPE2503	M5	7.8	7	4	$\phi 9$	70	2.2Nm

Dimension in mm

PE26 (SMD-FT)



Features

- For soldering in SMT, it is suitable for fully automated assembly.
- PCB connection for fixing cable lugs
- UNC thread or customer specific modifications on demand

特征

- 表面贴装焊接，适用于全自动组装
- 可将电缆线固定在电路板上
- 可按客户需求提供 UNC 螺纹或进行定制

Drawings

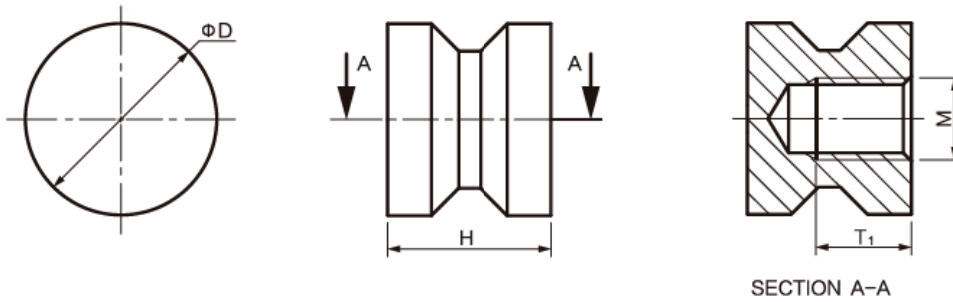

Technical Data

PROPERTIES	
Material	Brass
Surface	Tin
Solder Cream Thickness	150 μm
Heat Resistance	-55 °C up to +150 °C
Packaging	Bulk; Tape and Reel

Drawing No.	M	H	T ₁	ΦD
LFPE2601	M3	6	3.5	Φ7
LFPE2602	M4	7	4	Φ9
LFPE2603	M5	7	4	Φ9
LFPE2604	M6	11.5	6.5	Φ13
LFPE2605	M8	13.5	8	Φ13
LFPE2606	M10	17.5	11	Φ16

Dimension in mm

PE27 (SMD-FTP)



Features

- For soldering in SMT, it is suitable for fully automated assembly.
- PCB connection for fixing cable lugs
- UNC thread or customer specific modifications on demand

特征

- 表面贴装焊接，适用于全自动组装
- 可将电缆线固定在电路板上
- 可按客户需求提供 UNC 螺纹或进行定制

Drawings

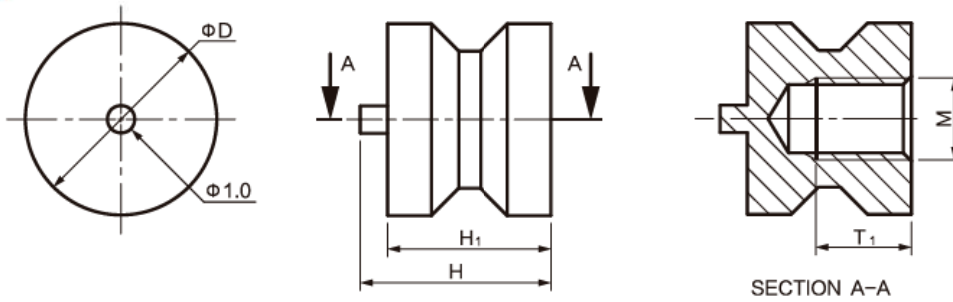

Technical Data

PROPERTIES	
Material	Brass
Surface	Tin
Solder Cream Thickness	150 μ m
Heat Resistance	-55 °C up to +150 °C
Packaging	Bulk; Tape and Reel

Drawing No.	M	H	H ₁	T ₁	ΦD
LFPE2701	M3	7	6	3.5	$\Phi 7$
LFPE2702	M4	8	7	4	$\Phi 9$
LFPE2703	M5	8	7	4	$\Phi 9$
LFPE2704	M6	12.5	11.5	6.5	$\Phi 10$
LFPE2705	M8	14.5	13.5	8	$\Phi 13$
LFPE2706	M10	18.5	17.5	11	$\Phi 16$

Dimension in mm

PE28 (SMD-ITT)



Features

- For soldering in SMT, it is suitable for fully automated assembly.
- PCB connection for fixing cable lugs
- UNC thread or customer specific modifications on demand

特征

- 表面贴装焊接，适用于全自动组装
- 可将电缆线固定在电路板上
- 可按客户需求提供 UNC 螺纹或进行定制

Drawings

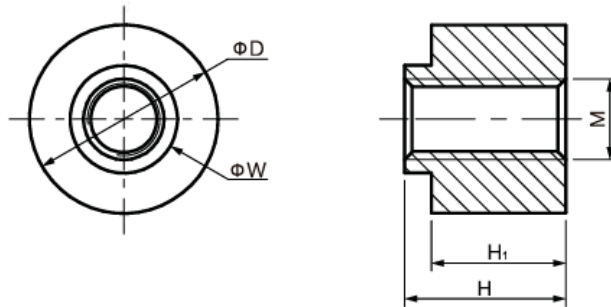

Technical Data

PROPERTIES	
Material	Brass
Surface	Tin
Solder Cream Thickness	150 μm
Heat Resistance	-55 °C up to +150 °C
Packaging	Bulk; Tape and Reel

Drawing No.	M	H	H ₁	φD	φW	IR (A)	Tightening Torque
LFPE2801	M3	4	3	φ7	φ4	50	0.5Nm
LFPE2802	M3	6	5	φ7	φ4	50	0.5Nm
LFPE2803	M4	4	3	φ7	φ5	50	1.2Nm
LFPE2804	M4	6	5	φ7	φ5	50	1.2Nm
LFPE2805	M5	6	5	φ9	φ6	70	2.2Nm

Dimension in mm

PE29 (SMD-FTT)



Features

- For soldering in SMT, it is suitable for fully automated assembly.
- PCB connection for fixing cable lugs
- UNC thread or customer specific modifications on demand

特征

- 表面贴装焊接，适用于全自动组装
- 可将电缆线固定在电路板上
- 可按客户需求提供 UNC 螺纹或进行定制

Drawings

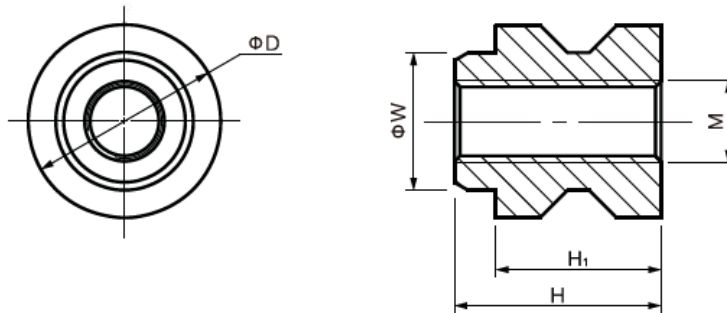

Technical Data

PROPERTIES	
Material	Brass
Surface	Tin
Solder Cream Thickness	150 μm
Heat Resistance	-55 °C up to +150 °C
Packaging	Bulk; Tape and Reel

Drawing No.	M	H	H ₁	ΦD	ΦW
LFPE2901	M3	7.5	6	Φ7	Φ5
LFPE2902	M4	8.5	7	Φ9	Φ6
LFPE2903	M5	8.5	7	Φ9	Φ6
LFPE2904	M6	13	11.5	Φ13	Φ9
LFPE2905	M8	15	13.5	Φ13	Φ9
LFPE2906	M10	19	17.5	Φ16	Φ12

Dimension in mm

PE30 (SMD-RA)



Features

- For soldering in SMT, it is suitable for fully automated assembly.
- PCB connection for fixing cable lugs
- UNC thread or customer specific modifications on demand

特征

- 表面贴装焊接，适用于全自动组装
- 可将电缆线固定在电路板上
- 可按客户需求提供 UNC 螺纹或进行定制

Drawings

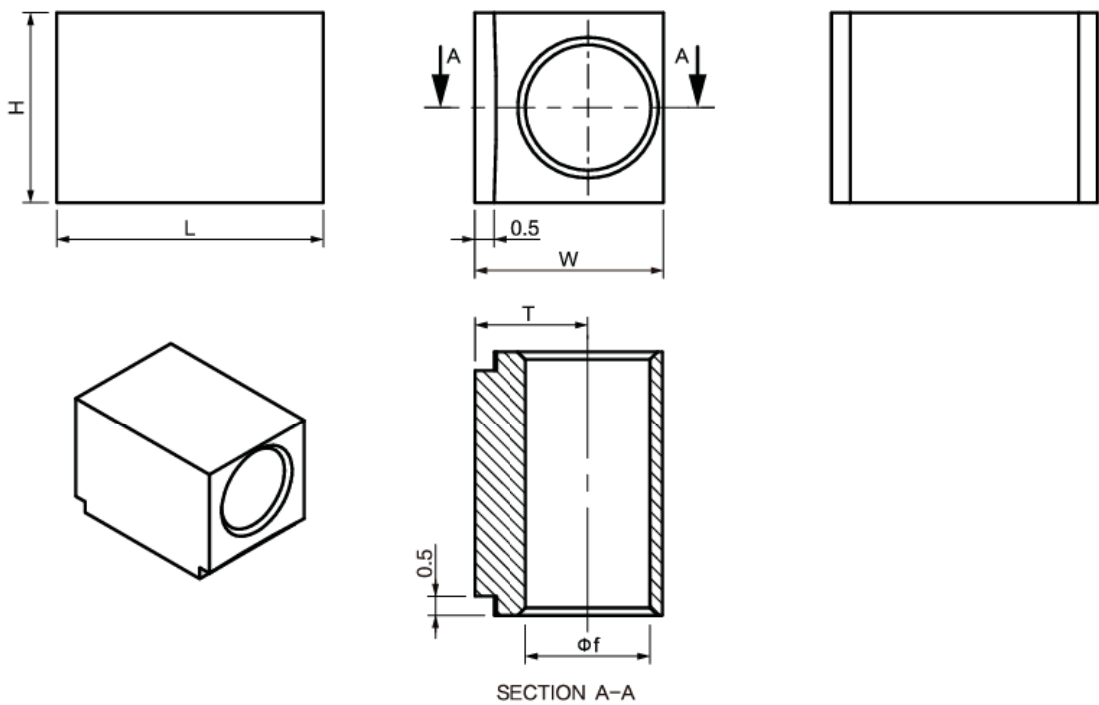

Technical Data

PROPERTIES	
Material	Brass
Surface	Tin
Solder Cream Thickness	120 μm
Heat Resistance	-55 °C up to +150 °C
Packaging	Bulk; Tape and Reel

Drawing No.	Φf/M	L	W	H	T	IR (A)	Tightening Torque
LFPE3001	Φ3.3	7	5	5	3	50	—
LFPE3002	M3	7	5	5	3	50	0.4Nm

Dimension in mm

PE31 (SMD-RAP)



Features

- For soldering in SMT, it is suitable for fully automated assembly.
- PCB connection for fixing cable lugs
- High mechanical forces and torques, Small footprint

特征

- 表面贴装焊接，适用于全自动组装
- 可将电缆线固定在电路板上
- 高机械力和扭矩，占用面积小

Drawings

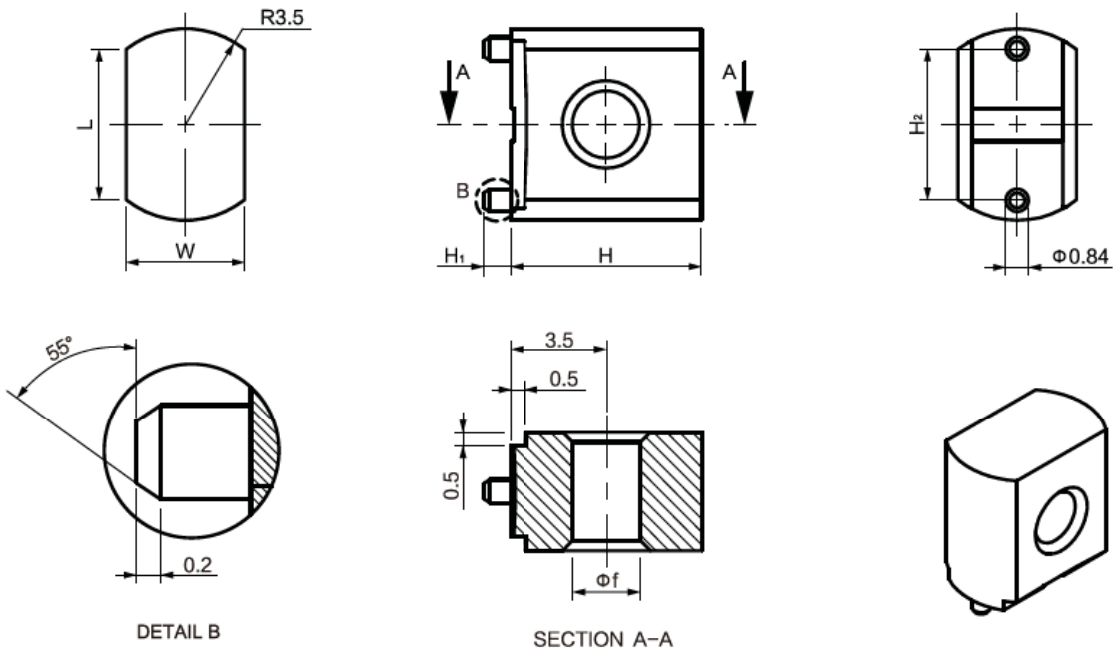

Technical Data

PROPERTIES	
Material	Brass
Surface	Tin
Solder Cream Thickness	120 μ m
Heat Resistance	-55 °C up to +150 °C
Packaging	Bulk; Tape and Reel

Drawing No.	$\phi f/M$	L	W	H	H_1	H_2	I R (A)	Tightening Torque
LFPE3101	$\phi 3.3$	5.5	4.33	7	1.0	5.54	50	—
LFPE3102	M3	5.5	4.33	7	1.0	5.54	50	0.4Nm

Dimension in mm

PE32

Features

- For soldering in SMT, Reels for fully automated assembly.
- PCB connection for fixing cable lugs
- UNC thread or customer specific modifications on demand

特征

- 表面贴装焊接，也可以用于全自动组装
- 可将电缆线固定在电路板上
- 可按客户需求提供 UNC 螺纹或进行定制

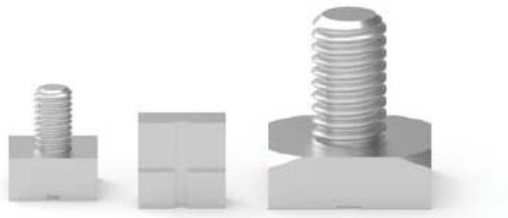

Drawings

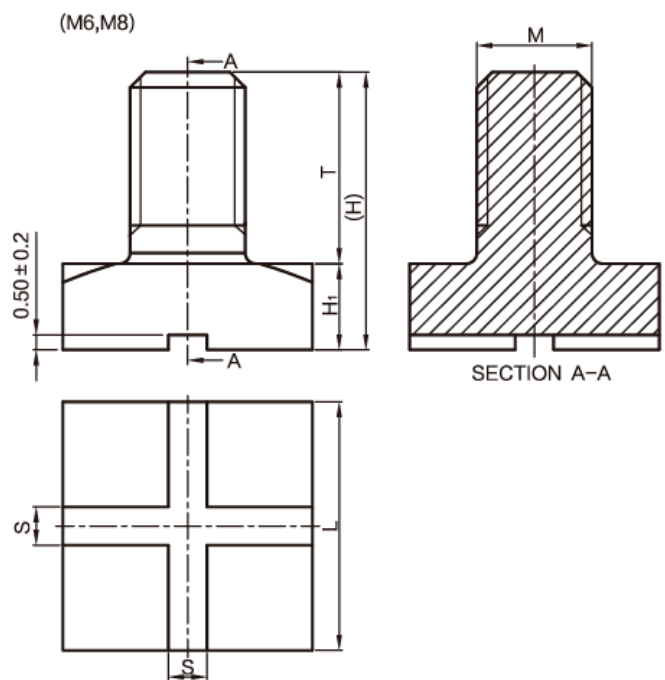
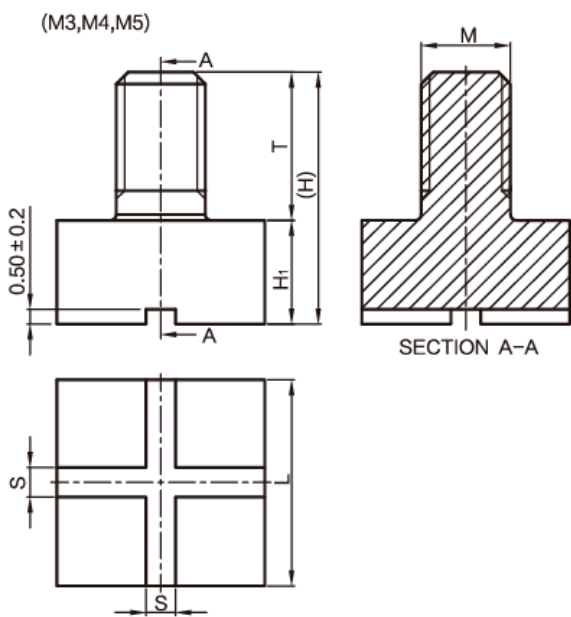

Technical Data

PROPERTIES	
Material	Brass
Surface	Tin
Solder Cream Thickness	150 μm
Heat Resistance	-55 °C up to +150 °C

Drawing No.	M	H	H ₁	T	L	S±0.2	IR (A)	Tightening Torque
LFPE3201	M3	8.5	3.5	5	7	1	54	0.5Nm
LFPE3202	M4	9.5	3.5	6	9	1	72	1.2Nm
LFPE3203	M5	11.5	3.5	8	9	1	98	2.2Nm
LFPE3204	M6	14.5	4.5	10	13	2	130	3.9Nm
LFPE3205	M8	17.5	4.5	13	13	2	198	9Nm

Dimension in mm

PE33

Features

- For soldering in SMT, Reels for fully automated assembly.
- PCB connection for fixing cable lugs
- UNC thread or customer specific modifications on demand

特征

- 表面贴装焊接，也可以用于全自动组装
- 可将电缆线固定在电路板上
- 高机械力和扭矩，占用面积小



Drawings

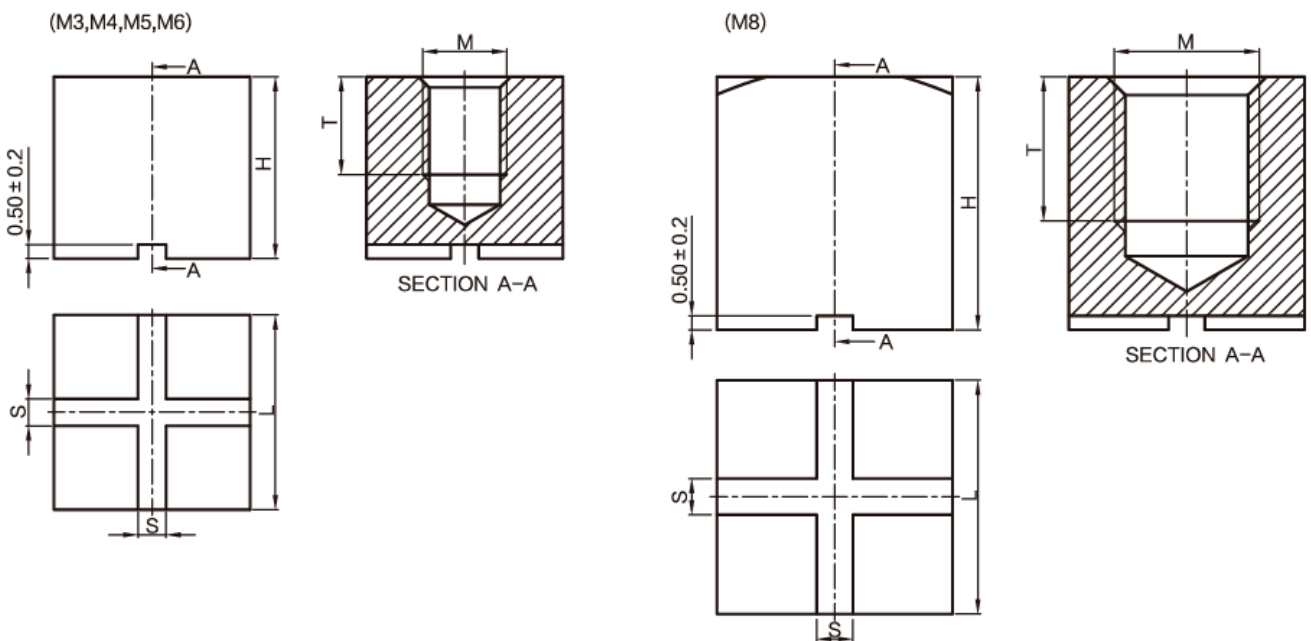

Technical Data

PROPERTIES	
Material	Brass
Surface	Tin
Solder Cream Thickness	150 μm
Heat Resistance	-55 °C up to +150 °C

Drawing No.	M	H	T	L	S±0.2	IR (A)	Tightening Torque
LFPE3301	M3	6.5	3.5	7	1	54	0.5Nm
LFPE3302	M4	7.5	4	9	1	72	1.2Nm
LFPE3303	M5	7.5	4	9	1	98	2.2Nm
LFPE3304	M6	11	6.5	10	1	130	3.9Nm
LFPE3305	M8	14	8	13	2	198	9Nm

Dimension in mm

In-sail® International with companies in:



地址：中国广东省深圳市龙华区昌永路和平工业园金星大厦B座13C
Jinxing Building 13C, Heping Industrial Zone, Changyong Road,
Longhua, Shenzhen, Guangdong, China.

Tel: +86-755-2900 2800 E-mail: sales@in-sail.com
Fax: +86-755-2900 2700 Website: <http://www.in-sail.com>

In-sail®

力帆&山本（中国）运营中心
In-sail & Sandum (China) Operation Center
深圳力帆精密五金有限公司
Shenzhen In-sail Precision Parts Co., Ltd
深圳山本精密五金部件有限公司
Shenzhen Sandum Precision Parts Co., Ltd
成都力本精密五金产品有限公司
Chengdu Leadum Precision Hardware Products Co., Ltd