

DV270QUM-R10
Product Specification
Rev. 0

FUZHOU BOE OPTOELECTRONICS TECHNOLOGY Co.,LTD

SPEC. NUMBER

S8-65-8D-345

PRODUCT GROUP

TFT-LCD

Rev. 0

ISSUE DATE

2023/06/08

PAGE

1 OF 37

REVISION HISTORY

() Preliminary specification

(√) Final specification

Rev No.	Page	Description of changes	Date	Prepared
P0	P5	1.3 General Specification	2023/02/03	Qin Xuefei
	P26	7.1 Dimensional Requirements	2023/02/03	Qin Xuefei
	P37	12.0 Figure 3	2023/02/03	Qin Xuefei
	P38	12.0 Figure 4	2023/02/03	Qin Xuefei
	P5	1.3 General Specification	2023/02/03	Lin Wenyuan
	P24	6.0 OPTICAL SPECIFICATIONS	2023/02/03	Lin Wenyuan
	P4~P22	1.0~6.0 Update	2023/02/03	Feng Xiangyu
	P27~P28	PACKING INFORMATION	2023/02/03	He Juanjuan
	P6、 P25	RELIABILITY TEST	2023/02/20	Chen Ming
P1	P5、 P22	Update Surface Treatment & Color Gamut	2023/03/14	Lin Wenyuan
	P5	Update Weight & Back-light	2023/03/14	Qin Xuefei
	P7	Update Power Consumption	2023/03/14	Wang Jing
	P22	Update Reproduction of color	2023/03/14	Wang Jing
	P6	Update Module Electrical Specifications	2023/03/14	Chen Ming
	P22	Update Reliability Test Parameters	2023/03/14	Chen Ming
	P4	Update Introduction	2023/03/14	Feng Xiangyu
	P5	Update Power Consumption	2023/03/14	Feng Xiangyu
	P7	Update Module Electrical Specifications	2023/03/14	Feng Xiangyu
	P8	Update Converter Electrical Specifications	2023/03/14	Feng Xiangyu
	P11	Update Input Connector Pin Configuration	2023/03/14	Feng Xiangyu
0	P7	Update Picture	2023/06/08	Feng Xiangyu
	P8	Update Power Rush Current	2023/06/08	Feng Xiangyu

Contents

No	ITEM	Page
	REVISIONS HISTORY	2
	CONTENTS	3
1	GENERAL DESCRIPTION	4
	1.1 Introduction	
	1.2 Features	
	1.3 Applications	
	1.4 General Specification	
2	ABSOLUTE MAXIMUM RATINGS	6
3	ELECTRICAL SPECIFICATIONS	7
	3.1 TFT LCD Module	
4	INTERFACE CONNECTION	10
	4.1 Module Input Signal & Power	
	4.2 LVDS Interface	
	4.3 LVDS Rx Interface Timing Parameter	
	4.4 LVDS Rx Interface Eye Diagram	
	4.5 LVDS Receiver Differential Input	
5	SIGNAL TIMING SPECIFICATIONS	18
	5.1 Timing Parameters (DE only mode)	
	5.2 Signal Timing Waveform	
	5.3 Input Signals, Basic Display Colors and Gray Scale of Colors	
	5.4 Power Sequence	
6	OPTICAL SPECIFICATIONS	22
7	MECHANICAL CHARACTERISTICS	24
8	RELIABILITY TEST	25
9	PRODCUT SERIAL NUMBER	26
10	PACKING INFORMATION	27
11	PRECAUTIONS	29
12	APPENDIX	34

1.0 GENERAL DESCRIPTION

1.1 Introduction

DV270QUM-R10 is a color active matrix TFT LCD MDL using amorphous silicon TFT's (Thin Film Transistors) as an active switching devices. This MDL has a 27 inch diagonally measured active area with UHD resolutions (3840 horizontal by 2160 vertical pixel array). Each pixel is divided into RED, GREEN, BLUE dots which are arranged in vertical stripe and this module can display 1.07B colors. The TFT-LCD MDL panel is adapted for a low reflection and higher color type.

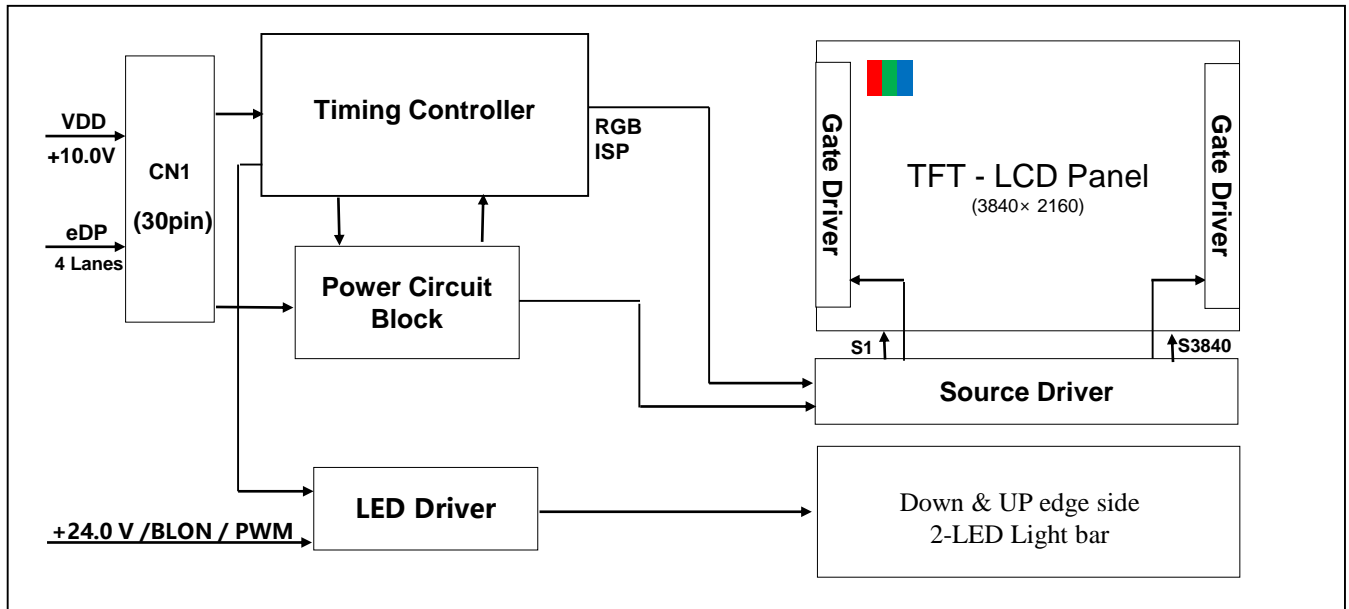

1.2 Features

- 4 lane eDP Interface with 5.4Gbps Link Rates
- High-speed response
- Low color shift image quality
- 10-bit (8bit+FRC) color depth, display 1.07B colors
- Wide viewing angle
- DE (Data Enable) only mode
- ADS technology is applied for high display quality
- RoHS compliant
- Landscape and Portrait Display
- 7*24Hrs Continuous Operation

1.3 Application

- Indoor Commercial Digital Display

1.4 General Specification

< Table 1. General Specifications >

Parameter	Specification	Unit	Remarks
Active area	596.736(H)*335.664(V)	mm	
Number of pixels	3840(H)×2160(V)	pixels	
Pixel pitch	0.1554(H) × 0.1554(V)	mm	
Pixel arrangement	Pixels RGB Vertical stripe		
Display colors	1.07B	colors	8bit+FRC
Display mode	Normally Black		
Dimensional outline	623.3(H)×362.3(V)×9.5(B)	mm	Detail refer to drawing
Weight	2800g (TYP)	g	±250g
Power Consumption	70.14	Watt	Typ.
Bezel width (L/R/U/D)	11.3/11.3/11.3/11.3	mm	
Surface Treatment	Haze 25% , 3H		
Back-light	Up & Down edge side 2-LED Light bar Type		

2.0 ABSOLUTE MAXIMUM RATINGS

The followings are maximum values which, if exceed, may cause faulty operation or damage to the unit. The operational and non-operational maximum voltage and current values are listed in Table 2.

< Table 2. Module Electrical Specifications >

[VSS=GND=0V]

Parameter	Symbol	Min.	Max.	Unit	Remark
Power Supply Voltage	VDD	VSS-0.3	12	V	Ta = 25 °C
	VBLU	VSS-0.3	26	V	Ta = 25 °C
Operating Temperature	T _{OP}	-20	+60	°C	Note 1
	T _{SUR}	-	+72	°C	
Storage Temperature	T _{ST}	-30	+70	°C	
Operating Ambient Humidity	Hop	5	80	%RH	
Storage Humidity	Hst	5	90	%RH	

Note 1 : Temperature and relative humidity range are shown in the figure below.
Wet bulb temperature should be 39 °C max. and no condensation of water.

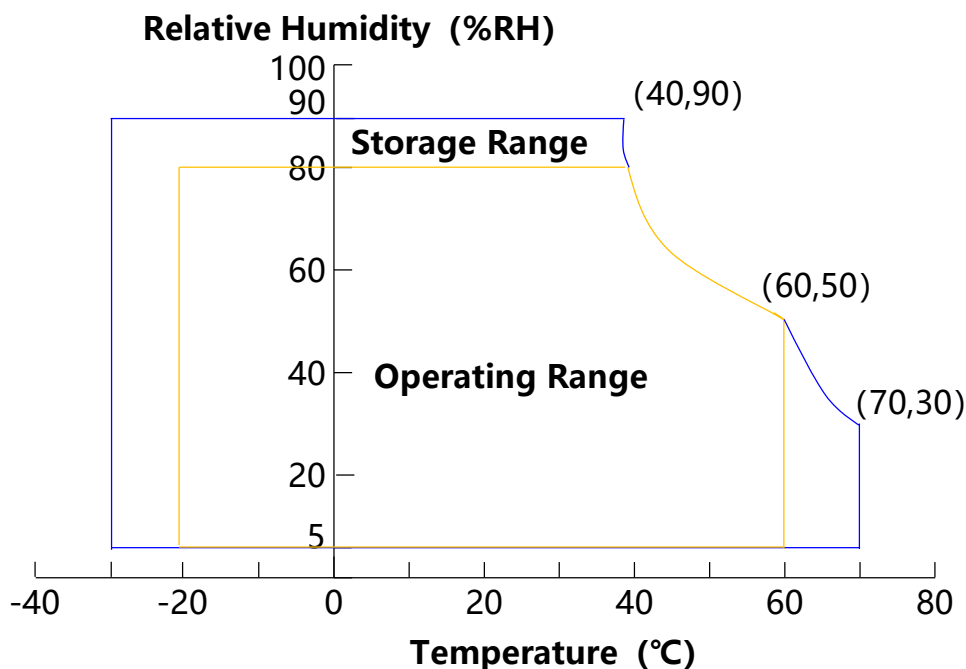

3.0 ELECTRICAL SPECIFICATIONS

3.1 TFT LCD Module

< Table 3. Module Electrical Specifications >

[Ta =25±2 °C]

Parameter.		Min.	Typ.	Max.	Unit	Remarks
Power Supply Voltage	V _{DD}	9.5	10.0	10.5	V	Note1
Power Supply Current	I _{DD}	-	1054	1600	mA	
In-Rush Current	I _{RUSH}	-	2.0	3.0	A	Note 2
Permissible Input Ripple Voltage	V _{RF}	-	-	300	mV	Note1,3
Main link swing voltage	V _{ID}	100	-	1320	mV	
Differential input common mode voltage	V _{cm}	0	-	2		
Power Consumption	P _D	-	10.54	16	W	
	P _{BL}	-	59.6	63.7	W	Note 4
	P _{total}	-	70.14	79.7	W	

Notes : 1. The supply voltage is measured and specified at the interface connector of LCM.

The current draw and power consumption specified is for VDD=10.0V, Frame rate=60Hz

Clock frequency = 533MHz. Test Pattern of power supply current

a) Typ : Color Bar

b) Max : H 1 Line



(a)



(b)

2. Duration of rush current is about 2 ms and rising time of VDD is 520 μs ± 20 %

3. Ripple Voltage should be covered by Input voltage Spec.

4. Calculated value for reference (Input pins*VPIN ×IPIN / Driver efficiency) including inverter loss.

3.0 ELECTRICAL SPECIFICATIONS

3.2 Converter Electrical Specifications

< Table 3. Converter Electrical Specifications >

[Ta =25±2 °C]

Parameter	Symbol	Values			Unit	Remark
		Min	Typ	Max		
Power Supply Input Voltage	VDD	21.6	24	26.4	Vdc	
Power Supply Ripple Voltage	VRP	-	-	300	mV	
Power Supply Current	IDD	-	2.48	2.65	A	
Power Consumption	PDD	-	59.6	63.7	Watt	PWM Duty =100%
Power Rush current	IRUSH	-	-	8	A	note1
Backlight On/Off Control Voltage	V _{B_{LON}} (off)	0	-	0.8	V	
	V _{B_{LON}} (on)	2.3	3.3	5	V	
Backlight PWM	High Level	2.3	3.3	5	V	On duty
	Low Level	0	-	0.8	V	Off duty
	Dimming Ratio	5	-	100	%	Note 2
	PWM Frequency	0.2	-	1	KHz	
LED luminous degradation Time	-	50000	-	-	Hrs	Note 3

Note 1 : The duration of rush current is rising time of Power Input is 10ms(min)

Note 2 :PWM Signal have to input available duty range. Between 95% and 100% Dimming Ratio duty have to be avoided. (95% < Dimming Ratio< 100%),But Dimming Ratio 100% is possible.

Note 3 : The LED luminous degradation Time is determined as the time which luminance of LED is 50% compare to the initial value at the typical LED current on condition of continuous operating in LCM state at 25±2 °C

4.0 INTERFACE CONNECTION

4.1 Module Interface Input Signal & Power : Cable length suggest less than 300mm

- eDP Connector : STM MSAK24025P30 or IPEX 20455-030E-66

< Table 4. Module Input Connector Pin Configuration >

Pin No	Symbol	Description	Pin No	Symbol	Description
1	VDD	Power Supply (10.0V)	16	Lane0P	Positive Signal For eDP Lane0
2	VDD	Power Supply (10.0V)	17	Lane0N	Negative Signal For eDP Lane0
3	VDD	Power Supply (10.0V)	18	GND	Ground
4	VDD	Power Supply (10.0V)	19	Lane1P	Positive Signal For eDP Lane1
5	VDD	Power Supply (10.0V)	20	Lane1N	Negative Signal For eDP Lane1
6	NC	No connection	21	GND	Ground
7	GND	Ground	22	Lane2P	Positive Signal For eDP Lane2
8	NC	SCL FOR PGMA	23	Lane2N	Negative Signal For eDP Lane2
9	NC	SDA FOR PGMA	24	GND	Ground
10	GND	Ground	25	Lane3P	Positive Signal For eDP Lane3
11	HPD	Hot Plug Detection Signal	26	Lane3N	Negative Signal For eDP Lane3
12	GND	Ground	27	GND	Ground
13	DAUXN	Negative Signal for Auxiliary Chanel	28	NC	No connection
14	DAUXP	Positive Signal for Auxiliary Chanel	29	NC	No connection
15	GND	Ground	30	NC	No connection

Rear view of LCM

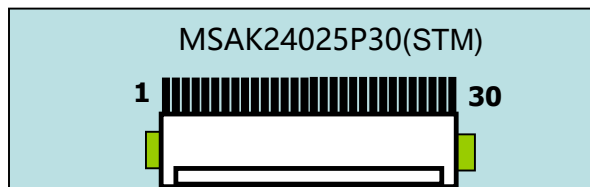

BIST Pattern



4.0 INTERFACE CONNECTION

4.1 CNT Dimension

-30pin Connector: MSAK24025P30

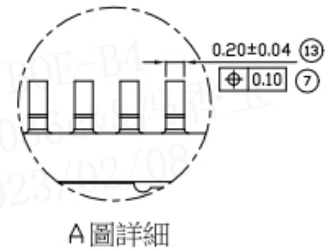
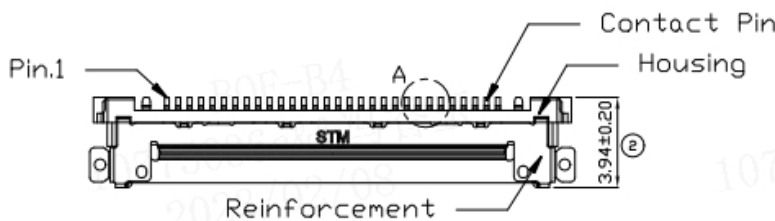
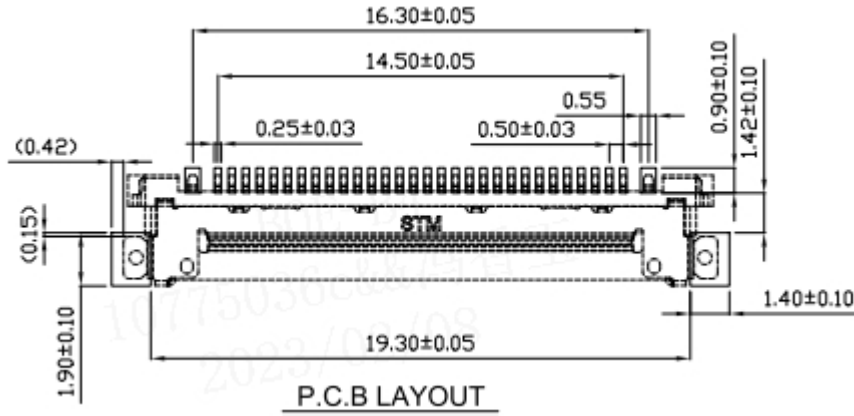

A圖詳細

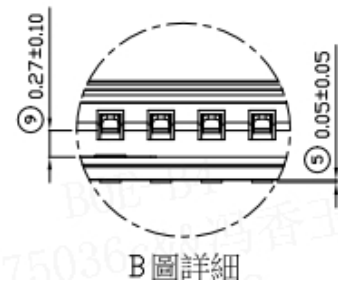
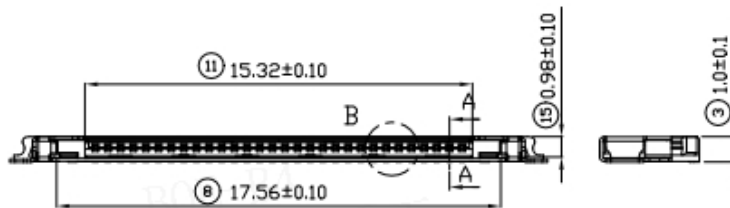

B圖詳細

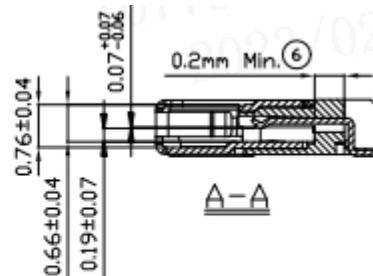
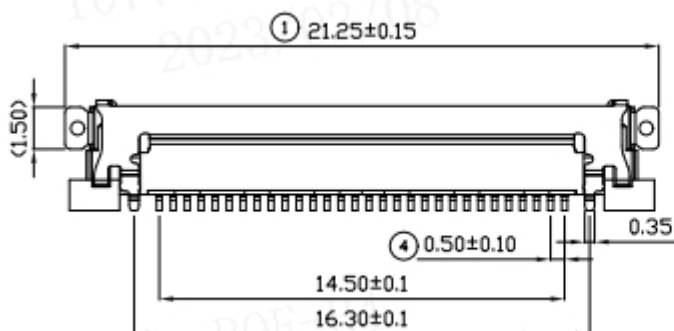

A-A

4.0 INTERFACE CONNECTION**4.2 BLU Input Signal & Power : Cable length suggest less than 300mm**

-Input Connector : CIO114M1HR0-NH

< Table 4. Input Connector Pin Configuration >

Pin No	Symbol	Description	Pin No	Symbol	Description
1	VIN(24V)	Power Supply (21.6V~26.4V)	8	GND	Ground
2	VIN(24V)	Power Supply (21.6V~26.4V)	9	GND	Ground
3	VIN(24V)	Power Supply (21.6V~26.4V)	10	GND	Ground
4	VIN(24V)	Power Supply (21.6V~26.4V)	11	NC	No connect
5	VIN(24V)	Power Supply (21.6V~26.4V)	12	VBLON	LED-EN VIH>2.3V, VIL<0.8V
6	GND	Ground	13	VPWM	PWM, 200Hz~1kHz, VIH>2.3V, VIL<0.8V, 5%~100%
7	GND	Ground	14	NC	No connect

-Output Connector : CI4602S-20P

< Table 5. Output Connector Pin Configuration >

Pin No	Symbol	Description	Pin No	Symbol	Description
1	LED1	LED-,CH1	11	LED7	LED-,CH1
2	LED2	LED-,CH1	12	LED8	LED-,CH1
3	LED3	LED-,CH1	13	LED9	LED-,CH1
4	NC	No connect	14	NC	No connect
5	LEDP1	LED+	15	LEDP3	LED+
6	LEDP2	LED+	16	LEDP4	LED+
7	NC	No connect	17	NC	No connect
8	LED4	LED-,CH1	18	LED10	LED-,CH1
9	LED5	LED-,CH1	19	LED11	LED-,CH1
10	LED6	LED-,CH1	20	LED12	LED-,CH1

4.0 Dimension

4.2 CNT Dimension

--14pin Connector: CIO114M1HR0-NH

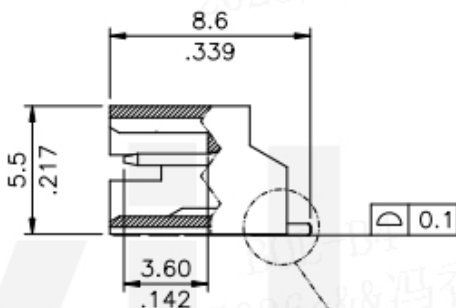
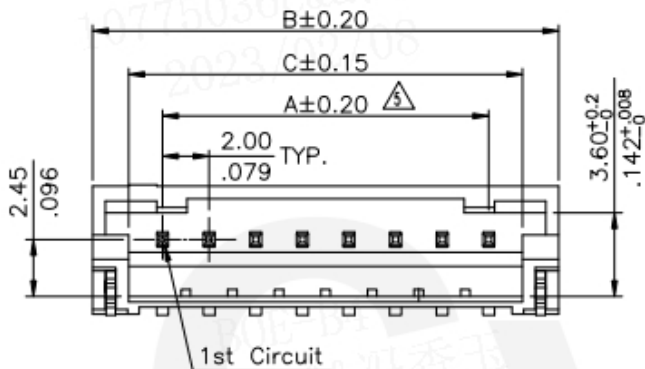
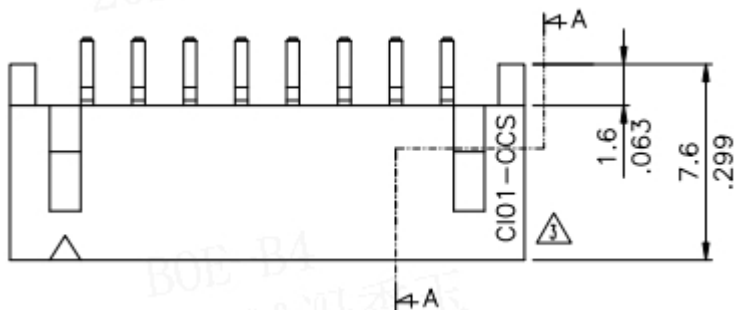

SEC.:A-A

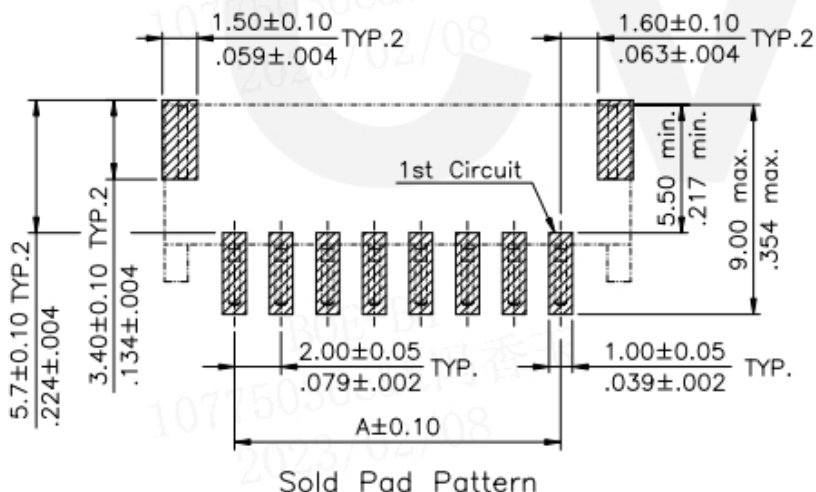

--20pin Connector: CI4602S-20P

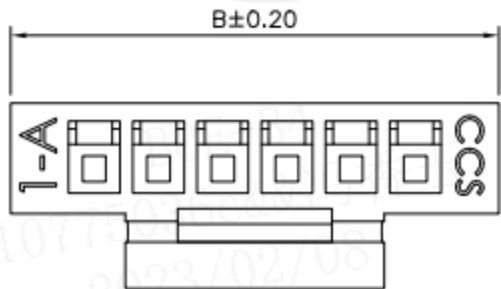
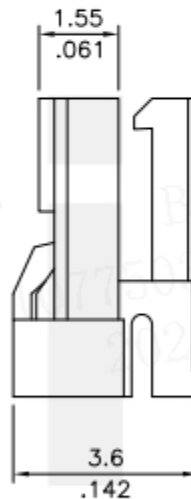
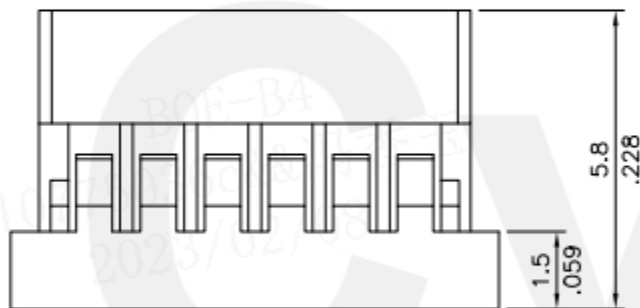
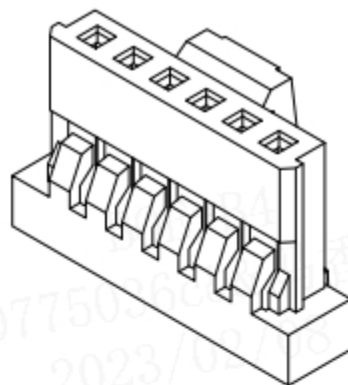
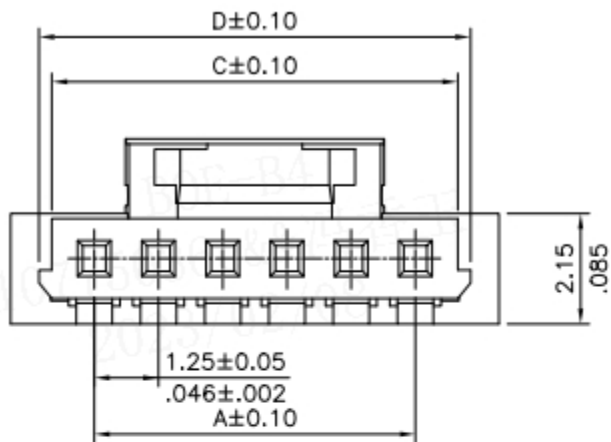

DIM. A = $1.25 \times \text{NO. OF SPACES}$
 DIM. B = DIM. A + 3.25
 DIM. C = DIM. A + 1.65
 DIM. D = DIM. A + 2.15
 * AVAILABLE IN 2 THROUGH 20

4.3 eDP Interface

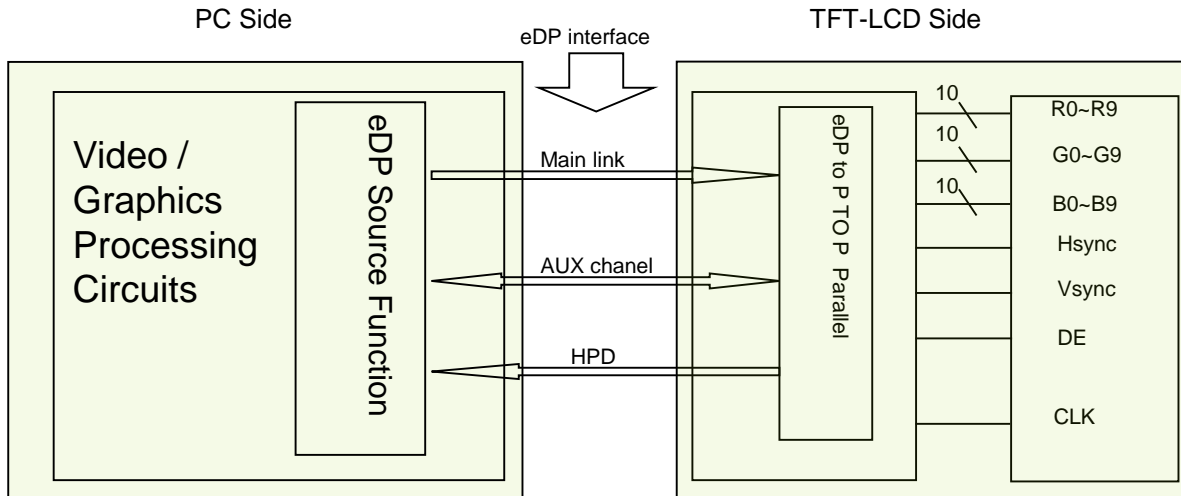

Note: Transmitter is not contained in Module.

4.3.1 eDP Main Link Signal

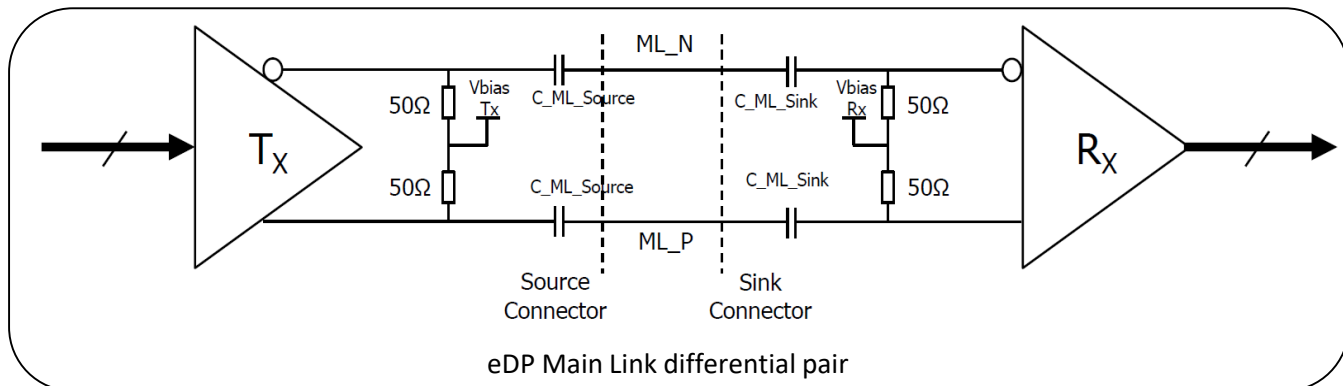

Parameter	Symbol	Min	Typ	Max	Unit	Notes
Unit Interval for high bit rate2(5.4Gbps/lane)	UI-HBR2		185		ps	
Link Clock Down Spreading	Amplitude	0		0.5	%	
	Frequency	30		33	kHz	
Differential peak-to-peak input voltage at package pins	$V_{RX-DIFFp-p}$	-	-	1.32	V	
EYE width at Sink side connector	$T_{RX-EYE-CONN}$	0.25			UI	
Lane-to-Lane skew	$L_{RX-SKEWINTER_PAIR}$			1250		
Lane intra-pair skew	$L_{RX-SKEWINTER_PAIR}$			50	ps	
AC Coupling Capacitor	C_{SOURCE_ML}	75		200	nF	Source side

4.3.2 eDP AUX Channel Signal

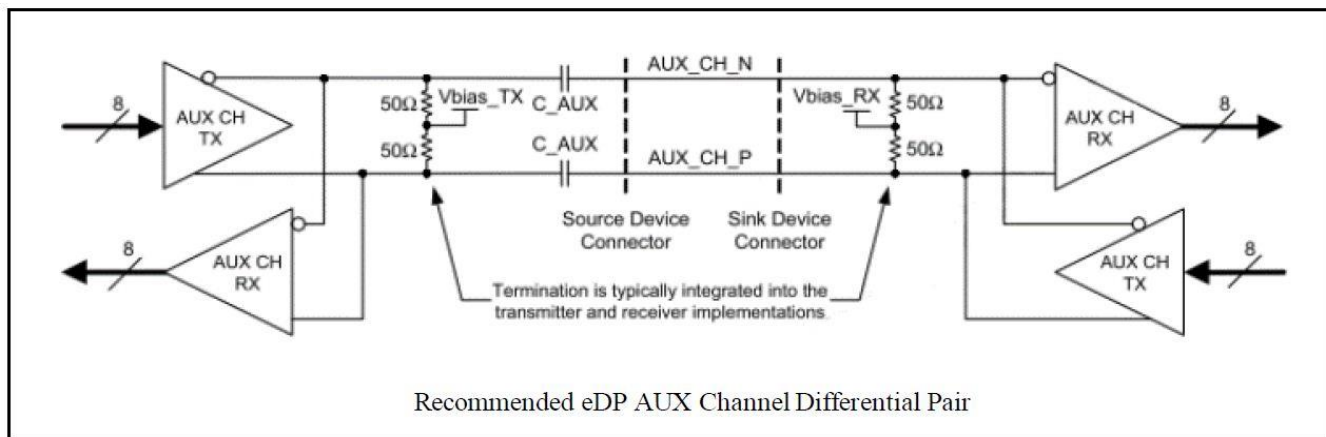

Parameter	Symbol	Min	Typ	Max	Unit	Notes
AUX Unit Interval	UI	0.4		0.6	μs	
AUX Jitter at Tx IC Package Pins	T_{jitter}			0.04	UI	
AUX Jitter at Rx IC Package Pins				0.05	UI	
AUX Peak-to-peak voltage at Connector Pins of Receiving	$V_{AUX-DIFFP-P}$	0.27		1.36	V	
AUX Peak-to-peak voltage at Connector Pins of Transmitting		0.29		1.38	V	
AUX DC common mode voltage	V_{AUX-CM_RX}	0		2.0	V	
	V_{AUX-CM_TX}	0		2.0	V	
AUX AC Coupling Capacitor	C_{SOURCE_ML}	75		200	nF	

4.3.3 eDP HPD Signal

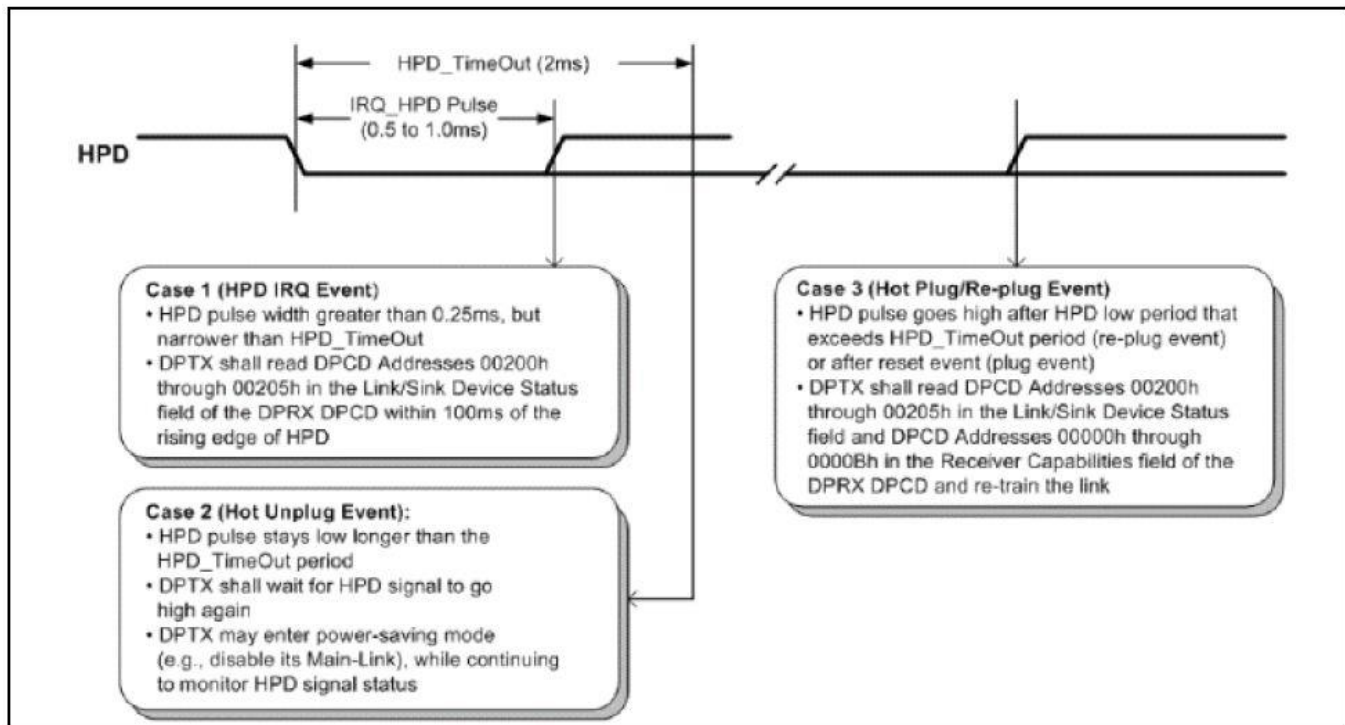

Case 1 (HPD IRQ Event)

- HPD pulse width greater than 0.25ms, but narrower than HPD_TimeOut
- DPTX shall read DPCD Addresses 00200h through 00205h in the Link/Sink Device Status field of the DPRX DPCD within 100ms of the rising edge of HPD

Case 2 (Hot Unplug Event):

- HPD pulse stays low longer than the HPD_TimeOut period
- DPTX shall wait for HPD signal to go high again
- DPTX may enter power-saving mode (e.g., disable its Main-Link), while continuing to monitor HPD signal status

Case 3 (Hot Plug/Re-plug Event)

- HPD pulse goes high after HPD low period that exceeds HPD_TimeOut period (re-plug event) or after reset event (plug event)
- DPTX shall read DPCD Addresses 00200h through 00205h in the Link/Sink Device Status field and DPCD Addresses 00000h through 0000Bh in the Receiver Capabilities field of the DPRX DPCD and re-train the link

Parameter	Symbol	Min	Typ	Max	Unit	Notes
HPD Voltage	HPD	2.25		3.6	V	Sink side Driving
HOT Plug Detection Threshold		2.0			V	Source side Detecting
HOT Unplug Detection Threshold				0.8	V	
HPD_IRQ Pulse Width	HPD_IRQ	0.5		1.0	ms	
HPD_TimeOut		2.0			ms	HPD Unplug Event

5.0 SIGNAL TIMING SPECIFICATION

5.1 Timing Parameters (DE only mode)

< Table 8. Timing Table >

Item	Symbols		Min	Typ	Max	Unit	Note
DCLK	Period	tCLK	1.8	1.9	2.2	ns	
	Frequency	-	444	533	551	MHz	
Horizontal	Horizontal Period	tHP	3950	4000	4088	tCLK	
	Horizontal Valid	tHV	3840			tCLK	
	Horizontal Blank	tHB	110	160	248		
	Frequency	fH	111	133.3	137	KHz	
Vertical	Vertical Period	tVP	2213	2222	2290	tHP	
	Vertical Valid	tVV	2160			tHP	
	Vertical Blank	tVB	53	62	130	tHP	
	Frequency	fV	50	60	62	Hz	

Note

1. DE Only Mode, While operation, DE signal should be have the same cycle. The input of HSYNC & VSYNC signal does not have an effect on normal operation.
2. Best operation clock frequency is 533Mhz.
3. Frequency] = [H Total] * [V Total] * [vertical Frame rate]
 H Total, V Total and Frame rate]should operate within the range between Frequency_Min and Frequency_Max
4. Except Best operation clock frequency, FOS(Flicker & Brightness & Crosstalk, Etc.) are not guaranteed.
5. Main frequency Max is 551 MHz without spread spectrum

5.3 Input Signals, Basic Display Colors and Gray Scale of Colors

< Table 10. Input Signal and Display Color Table >

Color		Input Color Data																											
		MSB RED LSB										MSB GREEN LSB										MSB BLUE LSB							
		R9	R8	R7	R6	R5	R4	R3	R2	R1	R0	G9	G8	G7	G6	G5	G4	G3	G2	G1	G0	B9	B8	B7	B6	B5	B4	B3	B2
Basic Color	Black	0	0	0	0	0	0	0	0	0	0	0	0	0	0	0	0	0	0	0	0	0	0	0	0	0	0	0	0
	Red(1023)	1	1	1	1	1	1	1	1	1	0	0	0	0	0	0	0	0	0	0	0	0	0	0	0	0	0	0	0
	Green(1023)	0	0	0	0	0	0	0	0	0	1	1	1	1	1	1	1	1	1	1	1	0	0	0	0	0	0	0	0
	Blue(1023)	0	0	0	0	0	0	0	0	0	0	0	0	0	0	0	0	0	0	0	0	1	1	1	1	1	1	1	1
	Cyan	0	0	0	0	0	0	0	0	0	1	1	1	1	1	1	1	1	1	1	1	1	1	1	1	1	1	1	1
	Magenta	1	1	1	1	1	1	1	1	1	0	0	0	0	0	0	0	0	0	0	0	1	1	1	1	1	1	1	1
	Yellow	1	1	1	1	1	1	1	1	1	1	1	1	1	1	1	1	1	1	1	1	0	0	0	0	0	0	0	0
	White	1	1	1	1	1	1	1	1	1	1	1	1	1	1	1	1	1	1	1	1	1	1	1	1	1	1	1	1
R	RED(000)	0	0	0	0	0	0	0	0	0	0	0	0	0	0	0	0	0	0	0	0	0	0	0	0	0	0	0	
	RED(001)	0	0	0	0	0	0	0	0	1	0	0	0	0	0	0	0	0	0	0	0	0	0	0	0	0	0	0	

	RED(1022)	1	1	1	1	1	1	1	1	1	0	0	0	0	0	0	0	0	0	0	0	0	0	0	0	0	0	0	
	RED(1023)	1	1	1	1	1	1	1	1	1	0	0	0	0	0	0	0	0	0	0	0	0	0	0	0	0	0	0	
G	Green (000)	0	0	0	0	0	0	0	0	0	0	0	0	0	0	0	0	0	0	0	0	0	0	0	0	0	0	0	
	Green (000)	0	0	0	0	0	0	0	0	0	0	0	0	0	0	0	0	0	0	0	1	0	0	0	0	0	0	0	

	Green (1022)	0	0	0	0	0	0	0	0	0	1	1	1	1	1	1	1	1	1	1	0	0	0	0	0	0	0	0	
	Green (1023)	0	0	0	0	0	0	0	0	0	1	1	1	1	1	1	1	1	1	1	0	0	0	0	0	0	0	0	
B	Blue(000)	0	0	0	0	0	0	0	0	0	0	0	0	0	0	0	0	0	0	0	0	0	0	0	0	0	0	0	
	Blue(000)	0	0	0	0	0	0	0	0	0	0	0	0	0	0	0	0	0	0	0	0	0	0	0	0	0	0	1	

	Blue(1022)	0	0	0	0	0	0	0	0	0	0	0	0	0	0	0	0	0	0	0	1	1	1	1	1	1	1	0	
	Blue(1023)	0	0	0	0	0	0	0	0	0	0	0	0	0	0	0	0	0	0	0	1	1	1	1	1	1	1	1	

6.5 Power Sequence

To prevent a latch-up or DC operation of the LCD module, the power on/off sequence shall be as shown in below.

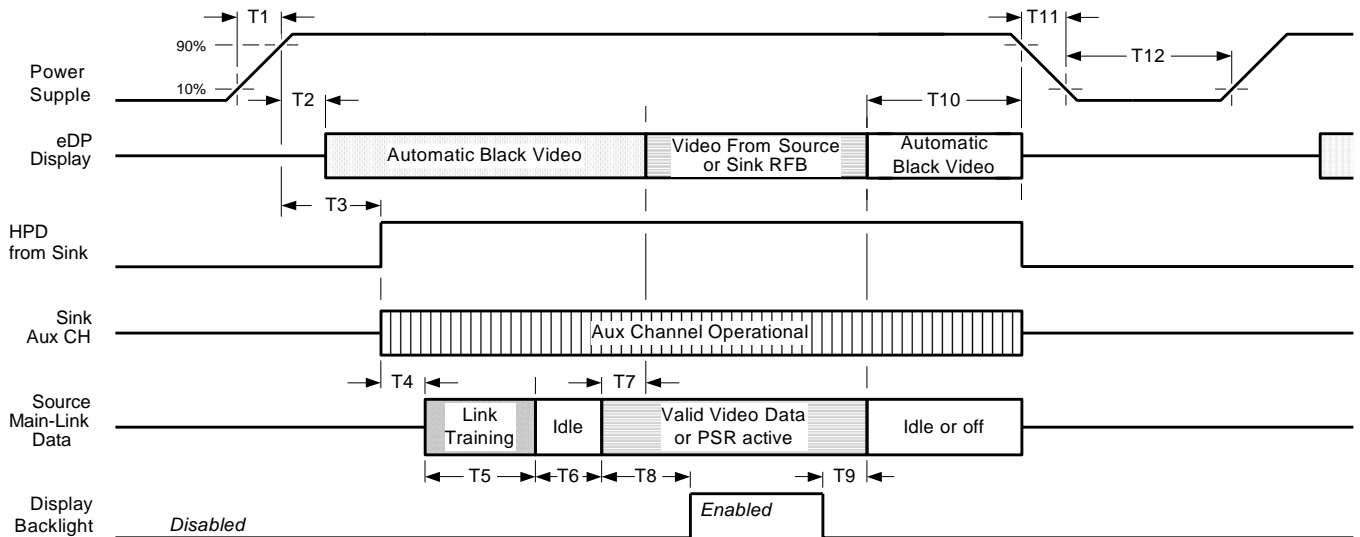

Timing Parameter	Description	Required By	Limits		Notes
			Min	Max	
T1	Power rail rise time, 10% to 90%	Source	0.5ms	10ms	
T2	Delay from Power Supply to automatic Black Video generation	Sink	0ms	120ms	Automatic Black Video generation prevents display noise until valid video data is received from the Source
T3	Delay from Power Supply to HPD high	Sink	0ms	120ms	Sink AUX Channel must be operational upon HPD high
T4	Delay from HPD high to link training initialization	Source	-	-	Allows for the Source to read Link capability and initialize
T5	Link training duration	Source	-	-	Dependant on the Source link training protocol
T6	Link idle	Source	-	-	Min accounts for required BS-Idle Pattern. Max allows for Source frame synchronization.

6.5 Power Sequence

To prevent a latch-up or DC operation of the LCD module, the power on/off sequence shall be as shown in below.

Timing Parameter	Description	Required By	Limits		Notes
			Min	Max	
T7	Delay from valid video data from Source to video on display	Sink	0ms	50ms	Max value allows for the Sink to validate video data and timing. At the end of T7, the Sink will indicate the detection of valid video data by setting the SINK_STATUS bit to logic 1 (DPCD 00205h, bit 0), and the Sink will no longer generate automatic Black Video.
T8	Delay from valid video data from Source to backlight enable	Source	200ms	-	The Source must assure display video is stable
T9	Delay from backlight disable to end of valid video data	Source	200ms	-	The Source must assure backlight is no longer illuminated. At the end of T9, the Sink will indicate the detection of no valid video data by setting the SINK_STATUS bit to logic 0 (DPCD 00205h, bit 0), and the Sink will automatically display Black Video.
T10	Delay from end of valid video data from Source to power off	Source	0ms	500ms	
T11	Power rail fall time, 90% to 10%	Source	0.5ms	10ms	
T12	Power off time	Source	1000ms	-	

Note 1: Even though T1 is over the specified value, there is no problem if the rush current is within Spec.

Note 2: When the power supply VDD is 0V, keep the level of input signals on the low or high impedance;

※ Please avoid floating state of interface signal at invalid period.

※ When the power supply for LCD (VDD) is off, be sure to pull down the valid and invalid data to 0V.

Note 3: Back Light must be turn on after power for logic and interface signal are valid, otherwise abnormal display would be shown. There is no reliability problem.

Note 4: T12 should be measured after the Module has been fully discharged between power off and on period

Note 5: T11: Voltage of VDD must decay smoothly after power-off, there should be none re-bouncing voltage. (customer system decide this value)

6.0 OPTICAL SPECIFICATIONS

The test of optical specifications shall be measured in a dark room (ambient luminance \leq 1 lux and temperature $=25\pm 2^{\circ}\text{C}$) with the equipment of Luminance meter system (Goniometer system and PR730) and test unit shall be located at an approximate distance 180cm from the LCD surface at a viewing angle of θ and Φ equal to 0° . We refer to $\theta_{\Phi=0}$ ($=\theta_3$) as the 3 o'clock direction (the "right"), $\theta_{\Phi=90}$ ($=\theta_{12}$) as the 12 o'clock direction ("upward"), $\theta_{\Phi=180}$ ($=\theta_9$) as the 9 o'clock direction ("left") and $\theta_{\Phi=270}$ ($=\theta_6$) as the 6 o'clock direction ("bottom"). While scanning θ and/or Φ , the center of the measuring spot on the Display surface shall stay fixed. The measurement shall be executed after 30 minutes warm-up period. VDD shall be 12.0V at 25°C . Optimum viewing angle direction is 6 'clock.

< Table 12. Optical Table >

[VDD = 10.0V, Frame rate = 60Hz, Ta = $25\pm 2^{\circ}\text{C}$]

Parameter		Symbol	Condition	Min	Typ	Max	Unit	Remark
Viewing Angle	Horizontal	Θ_3	CR > 10	85	89	-	Deg.	Note 1
		Θ_9		85	89	-	Deg.	
	Vertical	Θ_{12}		85	89	-	Deg.	
		Θ_6		85	89	-	Deg.	
Brightness		Lv		900	1000	-	nit	-
Contrast ratio		CR		1000:1	1200:1	-		Note 2
White luminance uniformity		ΔY		75	-	-	%	Note 3
Reproduction of color	White	W_x	$\Theta = 0^{\circ}$ (Center) Normal Viewing Angle	TYP. - 0.03	0.313	TYP. + 0.03		Note 4
		W_y			0.329			
	Red	R_x			0.644			
		R_y			0.352			
	Green	G_x			0.320			
		G_y			0.628			
	Blue	B_x			0.151			
		B_y			0.056			
Color Gamut	NTSC @CIE1931		72	-	-	%		
Response Time	G to G	T_g	-	14	20	ms	Note 5	
Gamma Scale				2.0	2.2	2.4		

Note :

1. Viewing angle is the angle at which the contrast ratio is greater than 10. The viewing are determined for the horizontal or 3, 9 o'clock direction and the vertical or 6, 12 o'clock direction with respect to the optical axis which is normal to the LCD surface.
2. Contrast measurements shall be made at viewing angle of $\theta = 0^\circ$ and at the center of the LCD surface. Luminance shall be measured with all pixels in the view field set first to white, then to the dark (black) state. (See Figure 1 shown in Appendix) Luminance Contrast Ratio (CR) is defined mathematically.

$$CR = \frac{\text{Luminance when displaying a white raster}}{\text{Luminance when displaying a black raster}}$$

3. The White luminance uniformity on LCD surface is then expressed as :

$$\Delta Y = (\text{Minimum Luminance of 9 points} / \text{Maximum Luminance of 9 points}) * 100$$

(See Figure 5 shown in Appendix).

4. The color chromaticity coordinates specified in Table 12. shall be calculated from the spectral data measured with all pixels first in red, green, blue and white. Measurements shall be made at the center of the panel. The BLU is used by BOE.
5. Response time Tg is the average time required for display transition by switching the input signal as below table and is based on Frame rate fV =60Hz to optimize. Each time in below table is defined as Figure 2 and shall be measured by switching the input signal for "any level of gray(bright)" and "any level of gray(dark)".

Measured Response Time	Target																
	0	15	31	47	63	79	95	111	127	143	159	175	191	207	223	239	255
0																	
15																	
31																	
47																	
63																	
79																	
95																	
111																	
127																	
143																	
159																	
175																	
191																	
207																	
223																	
239																	
255																	

7.0 MECHANICAL CHARACTERISTICS

7.1 Dimensional Requirements

Figure 3(located in Appendix) shows mechanical outlines for the model DV270QUM-R10 . Other parameters are shown in Table 13.

< Table 13. Dimensional Parameters >

Parameter	Specification	Unit
Dimensional outline	623.3(H)×362.3(V)×9.5(B)	mm
Weight	2800g (TYP)	gram
Active area	596.74 (H)×335.664(V)	mm
Pixel pitch	0.1554(H) × 0.1554(V)	mm
Number of pixels	3840 (H)×2160 (V) (1 pixel = R + G + B dots)	pixels
Back-light	Down & UP edge side 2-LED Light bar Type	

7.2 Mounting

See FIGURE 5. (shown in Appendix)

7.3 Anti-Glare and Polarizer Hardness.

The surface of the LCD has an anti-glare coating to minimize reflection and a coating to reduce scratching.

8.0 RELIABILITY TEST

The Reliability test items and its conditions are shown in below.

< Table 14. Reliability Test Parameters >

No	Test Items	Conditions
1	High temperature storage test	Ta = 70 °C, 240 hrs
2	Low temperature storage test	Ta = -30 °C, 240 hrs
3	High temperature & high humidity operation test	Ta = 50 °C, 80%RH, 240hrs
4	High temperature operation test	Ta = 60 °C, 240hrs
5	Low temperature operation test	Ta = -20 °C, 240hrs
6	Thermal shock	Ta = -20 °C ↔ 60 °C (0.5 hr), 100 cycle
7	Vibration test (non-operating)	Frequency 10 ~ 300 Hz, Sweep rate 30 min Gravity / AMP 1.49 G Period X, Y, Z 30 min
8	Electro-static discharge test (non-operating)	Air : 150 pF, 330Ω, 15 KV Contact : 150 pF, 330Ω, 8 KV

This test condition is based on BOE module.

9.0 PRODCUT SERIAL NUMBER

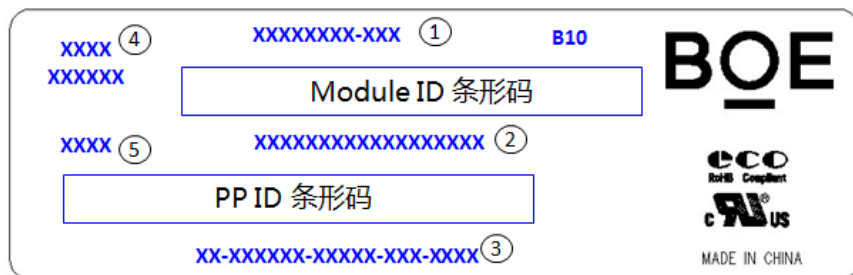

- ① FG-CODE
- ② Module ID, 最后一位为Revision Code (扫描不显示), 前17位编码规则如下
- ③ PPID (客户端ID)
- ④ D/PN码, 规格待确定
- ⑤ 生产年份+生产周别 (中间无空格)

MDL ID Naming Rule:

Digit	1	2	3	4	5	6	7	8	9	10	11	12	13	14	15	16	17
Code	S	L	S	A	1	0	8	5	9	4	2	0	0	0	1	D	B
Description	Product Code/GBN→FG-CODE—一对应		Grade	line	Year	Month	Model Extension Code (Last 4 Digits of FG-CODE)				Serial No. Hex-Decimal 000000-FFFFFF						

10.0 PACKING INFORMATION

BOE provides the standard shipping container for customers, unless customer specifies their packing information. The standard packing method and Barcode information are shown in below.

10.1 Packing Order

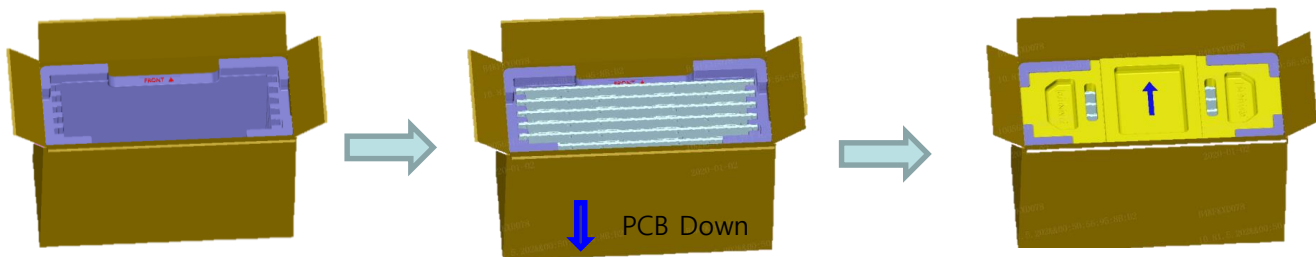

1. Put 1ea EPO Bottom into the inner box.

2. Put each module into a PE bag. Insert 6Pcs MDL into each box (PC B down).

3. Put 1ea EPO cover in and seal the box.

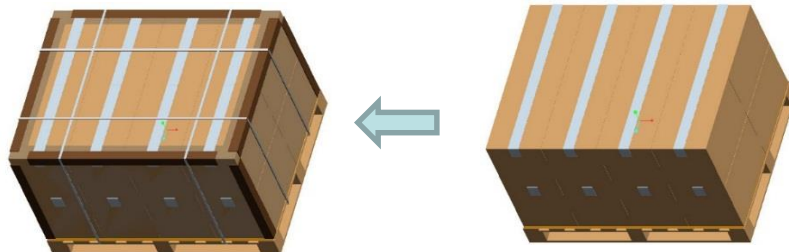

5. Put 8ea Paper Conner and wrap film around the boxes. Then pack with 4 packing belts.

4. Put the boxes on the pallet (16ea boxes per pallet)

10.2 Packing Note

- Box Dimension :701mm(L)×266mm(W)×450mm(H)
- Package Quantity in one Box : 6pcs

10.3 Box Label

- Label Size : 100mm (L) × 50mm (W)

- Contents

Model : DV270QUM-R10

Q`ty : Module 8 Q`ty in one box

Serial No. : Box Serial No.

Date : Packing Date

BOE
FUZHOU BOE OPTOELECTRONICS
TECHNOLOGY Co.,LTD

MODEL: XXXXXXXX-XXX ① Q'TY: XXX ②

SERIAL NO: XXXXXXXXXXXXXX ③ DATE: XXXX.XX.XX ④

Box ID 条形码

XXXXXXXXXXXXXX ⑤ XXXX ⑥



打印内容, 说明如下:

- ① FG-CODE
- ② 产品数量
- ③ Box ID, 编码规则如下
- ④ Box Packing 日期
- ⑤ 产品物料号(客户端)
- ⑥ FG-CODE 后四位

Digit Code	1	2	3	4	5	6	7	8	9	10	11	12	13
Code	X	X	X	X	1	6	3	D	0	0	1	A	1
Descripti on	Products G BN		Gra de	Line	Year		Mon th	Revisi on Code	Serial No.				

11.0 PRECAUTIONS

Please pay attention to the followings when you use this TFT LCD Module.

11.1 Mounting Precautions

- Use finger-stalls with soft gloves in order to keep display clean during the incoming inspection and assembly process.
- You must mount a module using specified mounting holes (Details refer to the drawings)
- You should consider the mounting structure so that uneven force (ex. Twisted stress, Concentrated stress) is not applied to the module. And the case on which a module is mounted should have sufficient strength so that external force is not transmitted directly to the module.
- Do not apply mechanical stress or static pressure on module; Abnormal display cause by pressing some parts of module during assembly process, do not belong to product failure, the press should be agreed by two sides.
- Determine the optimum mounting angle, refer to the viewing angle range in the specification for each model.
- Do not apply mechanical stress or static pressure on module, and avoid impact, vibration and falling.
- Acetic acid type and chlorine type materials for the cover case are not desirable because the former generates corrosive gas of attacking the polarizer at high temperature and the latter causes circuit break by electro-chemical reaction.
- Protection film for polarizer on the module should be slowly peeled off before display.
- Be careful to prevent water & chemicals contact the module surface.
- You should adopt radiation structure to satisfy the temperature specification.
- Do not touch, push or rub the exposed polarizers with glass, tweezers or anything harder than HB pencil lead. And please do not rub with dust clothes with chemical treatment. Do not touch the surface of polarizer for bare hand or greasy cloth. (Some cosmetics are detrimental to the polarizer.)
- When the surface becomes dusty, please wipe gently with absorbent cotton or other soft materials like chamois soaks with petroleum benzine. Normal-hexane & alcohol is recommended for cleaning the adhesives used to attach front / rear polarizers. Do not use acetone, toluene, because they cause chemical damage to the polarizer.
- Wipe off saliva or water drops as soon as possible. Their long time contact with polarizer causes deformations and color fading..

- This module has its circuitry PCB's on the rear side and Driver IC, should be handled carefully in order not to be stressed.
- Avoid impose stress on PCB and Driver IC during assembly process ,Do not drawing, bending, COF package & wire
- Do not disassemble the module.

11.2 Operating Precautions

- Do not connector or disconnect the cable to/from the Module at the "Power On" Condition.
- When the module is operating, do not lose CLK, ENAB signals. If any one of these signals is lost, the module would be damaged.
- Obey the supply voltage sequence. If wrong sequence is applied, the module would be damaged.
- Do not allow to adjust the adjustable resistance or switch
- The electrochemical reaction caused by DC voltage will lead to LCD module degradation, so DC drive should be avoided.
- The LCD modules use C-MOS LSI drivers, so customers are recommended that any unused input terminal would be connected to Vdd or Vss, do not input any signals before power is turn on, and ground you body, work/assembly area, assembly equipment to protect against static electricity.
- Do not exceed the absolute maximum rating value. (supply voltage variation, input voltage variation, variation in part contents and environmental temperature, and so on) Otherwise the Module may be damaged.
- Module has high frequency circuits. Sufficient suppression to the electromagnetic interference shall be done by system manufacturers. Grounding and shielding methods may be important to minimized the interference.
- Design the length of cable to connect between the connector for back-light and the converter as shorter as possible and the shorter cable shall be connected directly , The long cable between back-light and Converter may cause the Luminance of LED to lower and need a higher startup voltage
- The cables should be as short as possible between System Board and PCB interface.
- Connectors are precision devices to transmit electrical signals, and operators should plug in parallel
- Be careful for condensation at sudden temperature change. Condensation makes damage to polarizer or electrical contacted parts. And after fading condensation, smear or spot will occur.

11.3 Electrostatic Discharge Precautions

- Avoid the use work clothing made of synthetic fibers. We recommend cotton clothing or other conductivity-treated fibers.
- Since a module is composed of electronic circuits, it is not strong to electrostatic discharge. Make certain that treatment persons are connected to ground through wrist band etc.
- Do not close to static electricity to avoid product damage.
- Do not touch interface pin directly.

11.4 Precautions for Strong Light Exposure

- Do not leave the module operation or storage in Strong light . Strong light exposure causes degradation of polarizer and color filter.

11.5 Precautions for Storage

A. Atmosphere Requirement

ITEM	UNIT	MIN	TYP	MAX
Storage Temperature	(°C)	5	25	40
Storage Humidity	(%rH)	40	50	75
Storage Life	6 months			
Storage Condition	<ul style="list-style-type: none"> • The storage room should be equipped with a dark and good ventilation facility. • Prevent products from being exposed to the direct sunlight, moisture and water. • The product need to keep away from organic solvent and corrosive gas. • Be careful for condensation at sudden temperature change. • Storage condition is guaranteed under packing conditions. 			

B. Package Requirement

- The product should be placed in a sealed polythene bag.
- Product Should be placed on the pallet, Which is away from the floor, Be cautions not to pile the product up.
- The polarizer surface should not come in contact with any other object. It is recommended that they be stored in the container in which they were shipped.
- As the original protective film, do not use the adhesive protective film to avoid change of Pol color and characteristic.

BOE	PRODUCT GROUP	REV	ISSUE DATE
	Customer SPEC	Rev. 0	2023/06/08

11.6 Precautions for protection film

- Remove the protective film slowly, keeping the removing direction approximate 30-degree not vertical from panel surface, If possible, under ESD control device like ion blower, and the humidity of working room should be kept over 50%RH to reduce the risk of static charge.
- People who peeled off the protection film should wear anti-static strap and grounded well.

11.7 Appropriate Condition for Commercial Display

-Generally large-sized LCD modules are designed for consumer applications . Accordingly, long-term display like in Commercial Display application, can cause uneven display including image sticking. To optimize module's lifetime and function, several operating usages are required.

1. Normal operating condition

- Temperature: $20 \pm 15^{\circ}\text{C}$
- Operating Ambient Humidity : $55 \pm 20\%$
- Display pattern: dynamic pattern (Real display)
- Well-ventilated place is recommended to set up Commercial Display system

2. Special operating condition

a. Ambient condition

- Well-ventilated place is recommended to set up Commercial Display system.

b. Power and screen save

- Periodical power-off or screen save is needed after long-term display.

c. As the low temperature, the response time is greatly delayed. As the high temperatures (higher than the operating temperature) the LCD module may turn black screen. The above phenomenon cannot explain the failure of the display. When the temperature returns to the normal operating temperature, the LCD module will return to normal display.

d. When expose to drastic fluctuation of temperature (hot to cold or cold to hot) ,the LCD module may be affected; Specifically, drastic temperature fluctuation from cold to hot ,produces dew on the LCD module 's surface which may affect the operation of the polarizer and LCD module

e. Do not exceed the absolute maximum rating value. (supply voltage variation, input voltage variation, variation in part contents and environmental temperature, and so on) Otherwise the Module may be damaged.

f. Products exposed to low temperature environment for a long time, need to carry out necessary protection , low temperature environment is usually refrigerators , vending machine Etc...

g. Long time and large angle forward use or unconventional use , It is strongly recommended to contact BOE for filed application engineering advice

SPEC. NUMBER S8-65-8D-345	SPEC. TITLE DV270QUM-R10 Product Specification Rev.0	PAGE OF 37
------------------------------	---	---------------

h. Product reliability and functions are only guaranteed when the product is used under right operation usages. If product will be used in extreme conditions such as high temperature, high humidity, high altitude, special display images, running time, long time operation, outdoor operation, etc. It is strongly recommended to contact BOE for filed application engineering advice. Otherwise, its reliability and function may not be guaranteed. Extreme conditions are commonly found at airports, transit stations, banks, stock market and controlling systems.

3. Operating usages to protect against image sticking due to long-term static display.

a. Suitable operating time: under 20 hours a day.

b. Static information display recommended to use with moving image.

- Cycling display between 5 minutes' information(static) display and 10 seconds' moving image.

c. Background and character (image) color change

- Use different colors for background and character, respectively.

- Change colors themselves periodically.

d. Avoid combination of background and character with large different luminance.

1) Abnormal condition just means conditions except normal condition.

2) Black image or moving image is strongly recommended as a screen save

4. Lifetime in this spec. is guaranteed only when Commercial Display is used according to operating usages.

5. Module should be turned clockwise based on front view when used in portrait mode.

11.8 Other Precautions

A. LC Leak

- If the liquid crystal material leaks from the panel, it is recommended to wash the LC with acetone or ethanol and then burn it.
- If the liquid crystal material leaks from the panel, it should be kept away from the eyes or mouth. In case of contact with hands, skin or clothes, it has to be washed away thoroughly with soap.
- If LC in mouth, mouth need to be washed, drink plenty of water to induce vomiting and follow medical advice.
- If LC touch eyes, eyes need to be washed with running water at least 15 minutes.

B. Rework

- When returning the module for repair or etc., Please pack the module not to be broken. We recommend to use the original shipping packages.

C. In order to prevent potential problems, flicker should be adjusted by optimizing the Vcom value in customer LCM Line through the I2C Interface. (Q/Single/OC 出货时填写)

12.0 APPENDIX

< Figure 1. Measurement Set Up >

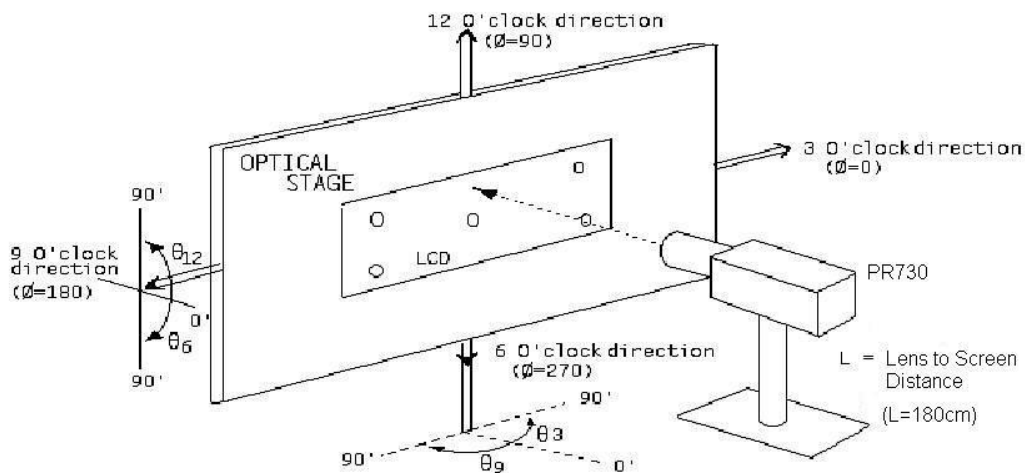

< Figure 2. Response Time Testing >

Any level of gray (Bright)

Any level of gray (Dark)

Any level of gray (Bright)

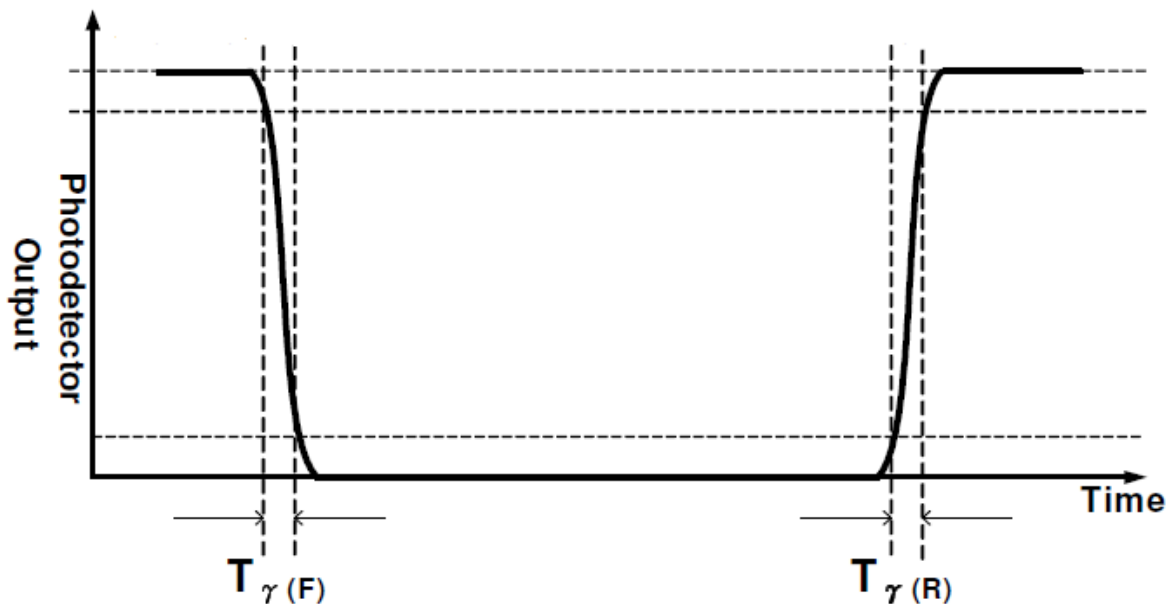

< Figure 3.TFT-LCD Module Outline Dimensions (Front View) >

4-M3 USER HOLE
DEPTH 4.0mm MAX

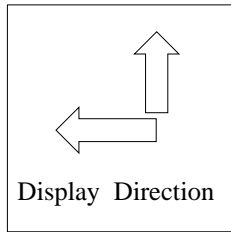
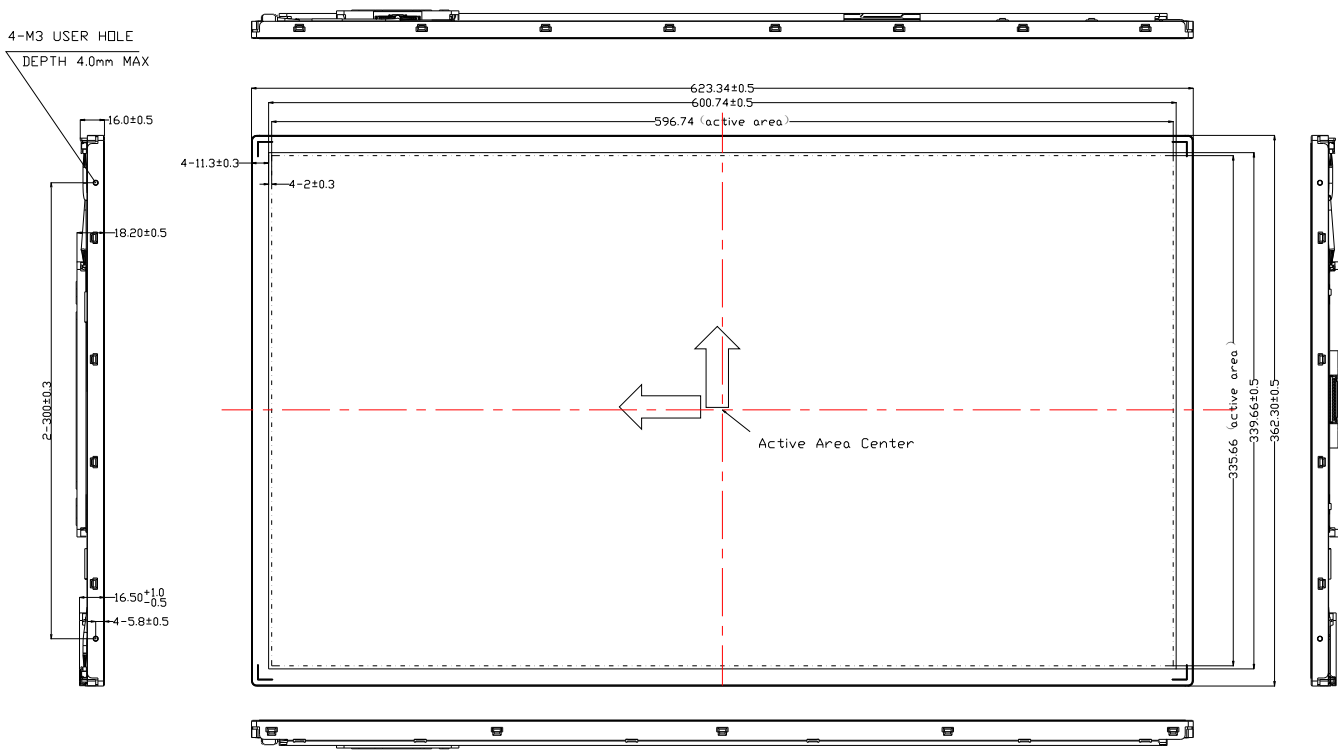

< Figure 4.TFT-LCD Module Outline Dimensions (Rear View) >

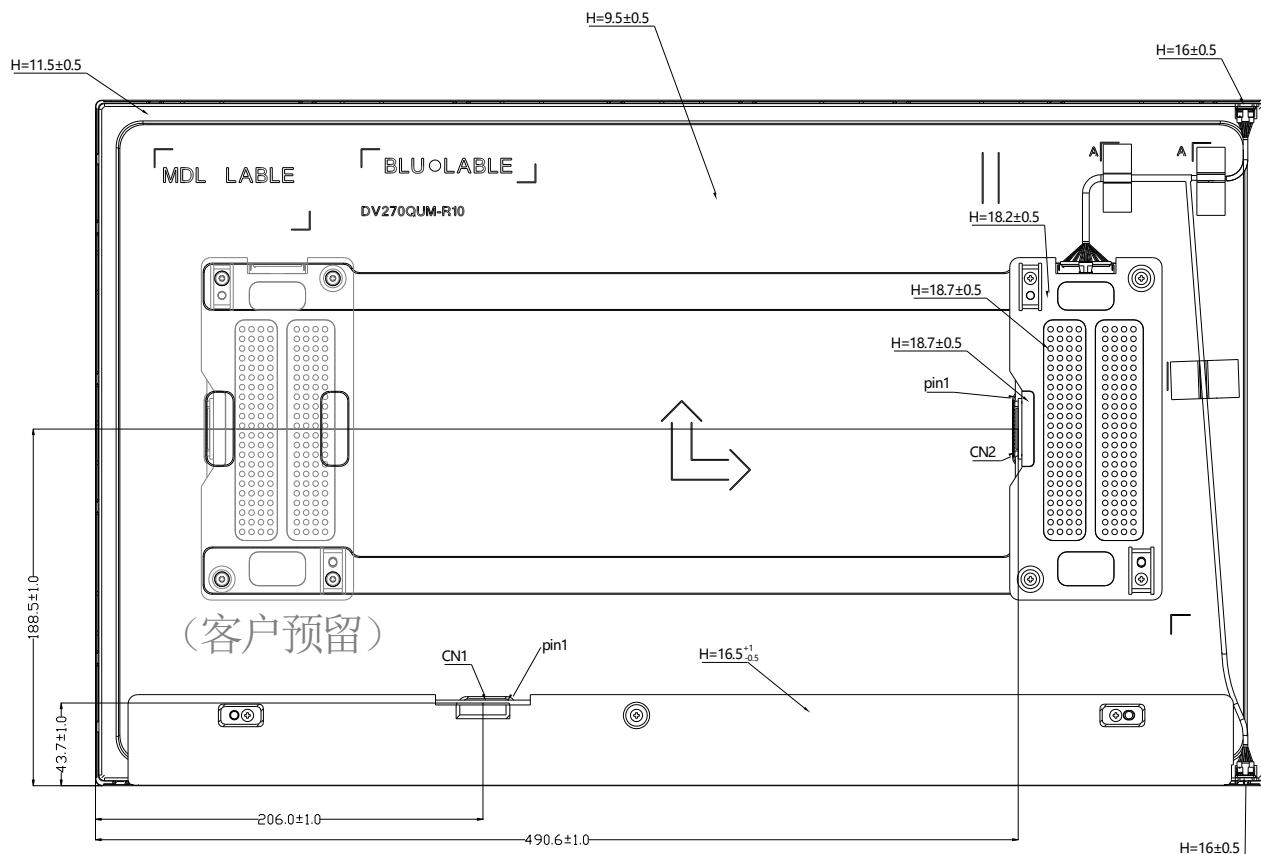

< Figure 5. White Luminance and Uniformity Measurement Locations >

