

Jan.1.2022 Copyright 2022 HIROSE ELECTRIC CO., LTD. All Rights Reserved.
 In case of consideration for using Automotive equipment / device which demand high reliability, kindly contact our sales window correspondents.

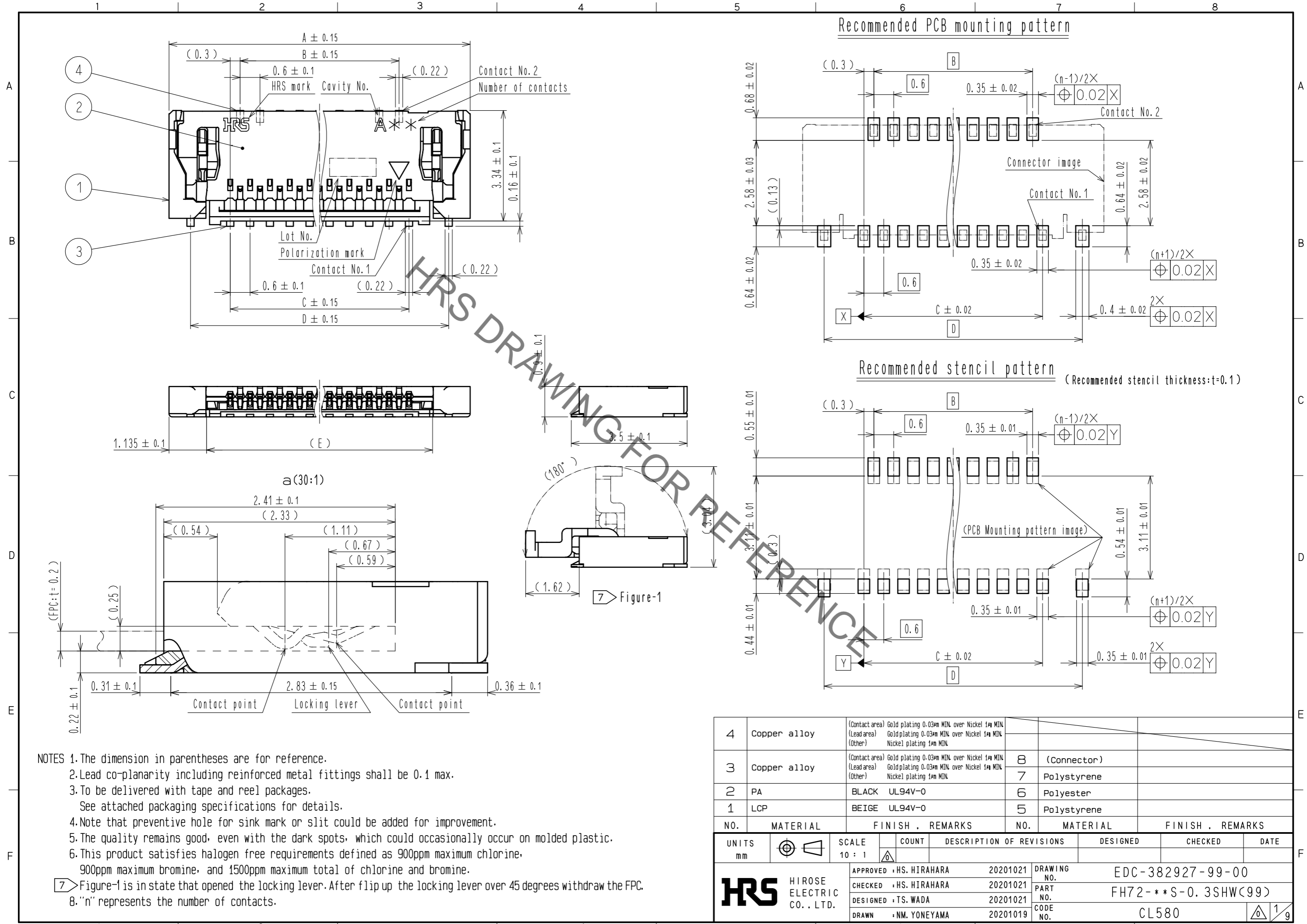

NOTES

- The dimension in parentheses are for reference.
- Lead co-planarity including reinforced metal fittings shall be 0.1 max.
- To be delivered with tape and reel packages.
See attached packaging specifications for details.
- Note that preventive hole for sink mark or slit could be added for improvement.
- The quality remains good, even with the dark spots, which could occasionally occur on molded plastic.
- This product satisfies halogen free requirements defined as 900ppm maximum chlorine, 900ppm maximum bromine, and 1500ppm maximum total of chlorine and bromine.
- Figure-1 is in state that opened the locking lever. After flip up the locking lever over 45 degrees withdraw the FPC.
- "n" represents the number of contacts.

4	Copper alloy	(Contact area) Gold plating 0.03μm MIN. over Nickel 1μm MIN. (Lead area) Gold plating 0.03μm MIN. over Nickel 1μm MIN. (Other) Nickel plating 1μm MIN.			
3	Copper alloy	(Contact area) Gold plating 0.03μm MIN. over Nickel 1μm MIN. (Lead area) Gold plating 0.03μm MIN. over Nickel 1μm MIN. (Other) Nickel plating 1μm MIN.	8	(Connector)	
2	PA	BLACK UL94V-0	7	Polystyrene	
1	LCP	BEIGE UL94V-0	6	Polyester	
			5	Polystyrene	
NO.	MATERIAL	FINISH . REMARKS	NO.	MATERIAL	FINISH . REMARKS
UNITS mm		SCALE 10 : 1	COUNT 	DESCRIPTION OF REVISIONS	DESIGNED
					CHECKED
					DATE
HRS	HIROSE ELECTRIC CO., LTD.	APPROVED : HS. HIRAHARA 20201021 CHECKED : HS. HIRAHARA 20201021 DESIGNED : TS. WADA 20201021 DRAWN : NM. YONEYAMA 20201019	DRAWING NO. PART NO. CODE NO.	EDC-382927-99-00 FH72-**S-0.3SHW(99) CL580	

Jan.1.2022 Copyright 2022 HIROSE ELECTRIC CO., LTD. All Rights Reserved.
In case of consideration for using Automotive equipment / device which demand high reliability, kindly contact our sales window correspondents.

Recommended FPC (20:1) (Exposed conductor area thickness: $t=0.20 \pm 0.03$)

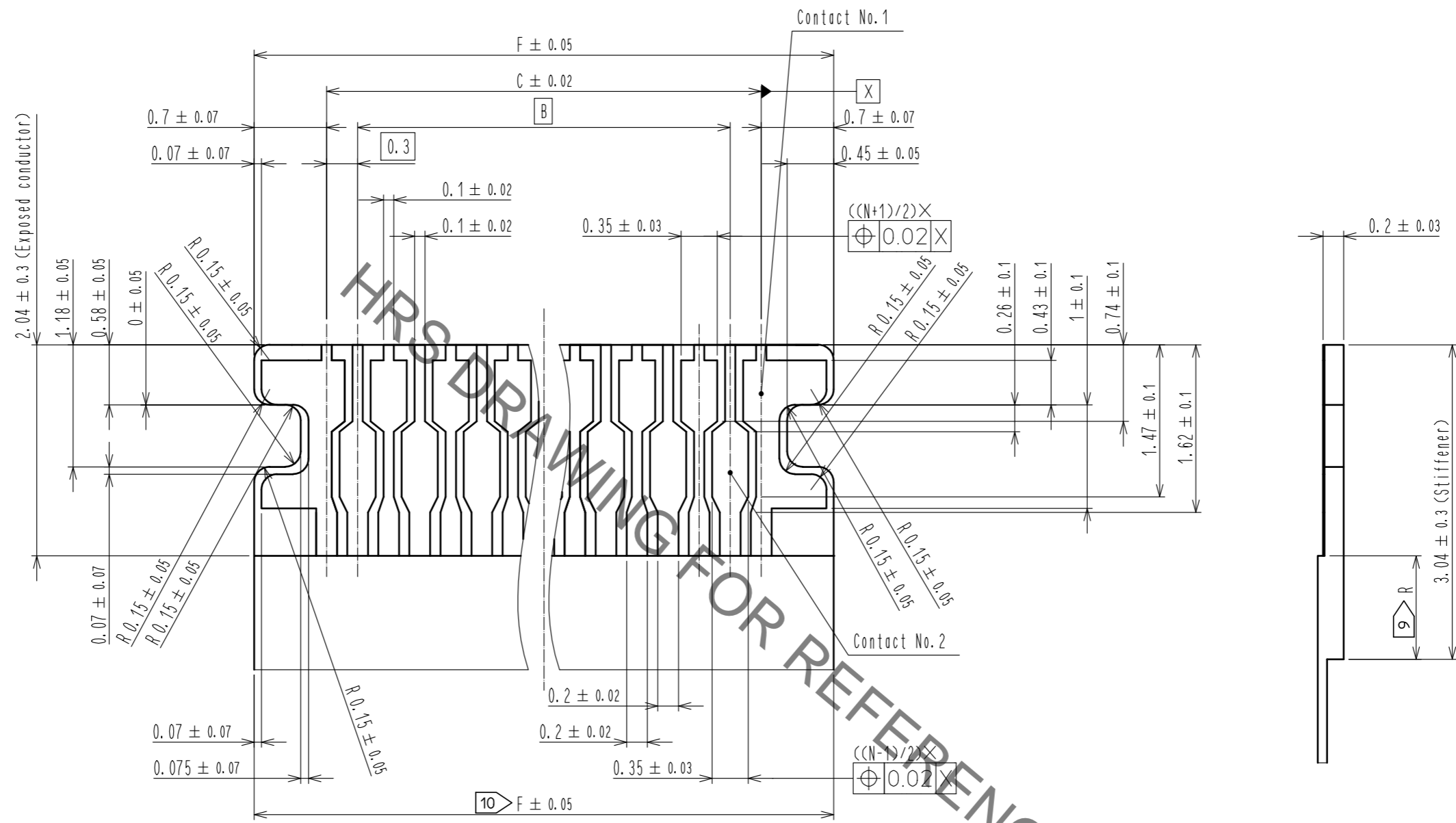

NOTES $\square 9$ Dimension R must be 0.5mm minimum.
 $\square 10$ Indicated tolerance is applicable to the exposed conductor.

FPC Configuration(Reference example)
(FREE)

MATERIAL NAME	MATERIAL	THICKNESS(#m)
Covering film layer.	Polyimide 1mil	25
Cover adhesive		25
Surface treatment	1#m to 6#m nickel underplated 0.2#m gold plated	(4)
Copper foil	Cu 1 oz	35
Base adhesive	Heat-hardened adhesive	25
Base film	Polyimide 1mil	25
Reinforcement material adhesive	Heat-hardened adhesive	35
Stiffener	Polyimide 5mil	75

<Recommended FPC>

HRS	DRAWING NO.	EDC-382927-99-00
	PART NO.	FH72-**S-0.3SHW(99)
	CODE NO.	CL580

Jan.1.2022 Copyright 2022 HIROSE ELECTRIC CO., LTD. All Rights Reserved.
 In case of consideration for using Automotive equipment / device which demand high reliability, kindly contact our sales window correspondents.

Embossed carrier tape dimension (2:1)

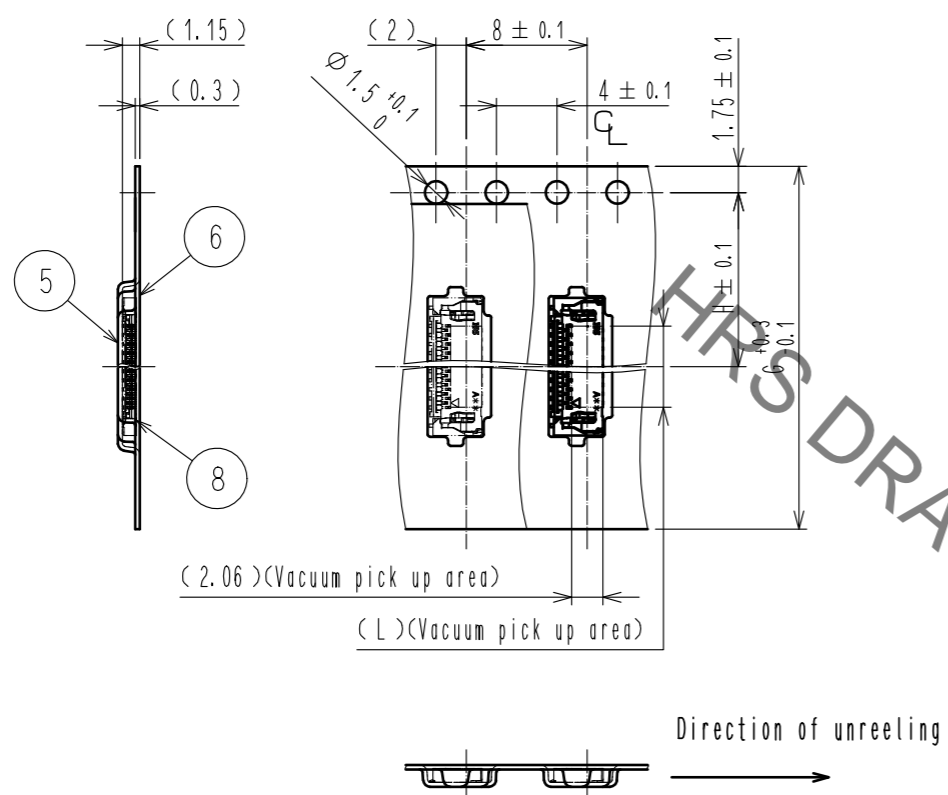

Reel dimension (FREE)

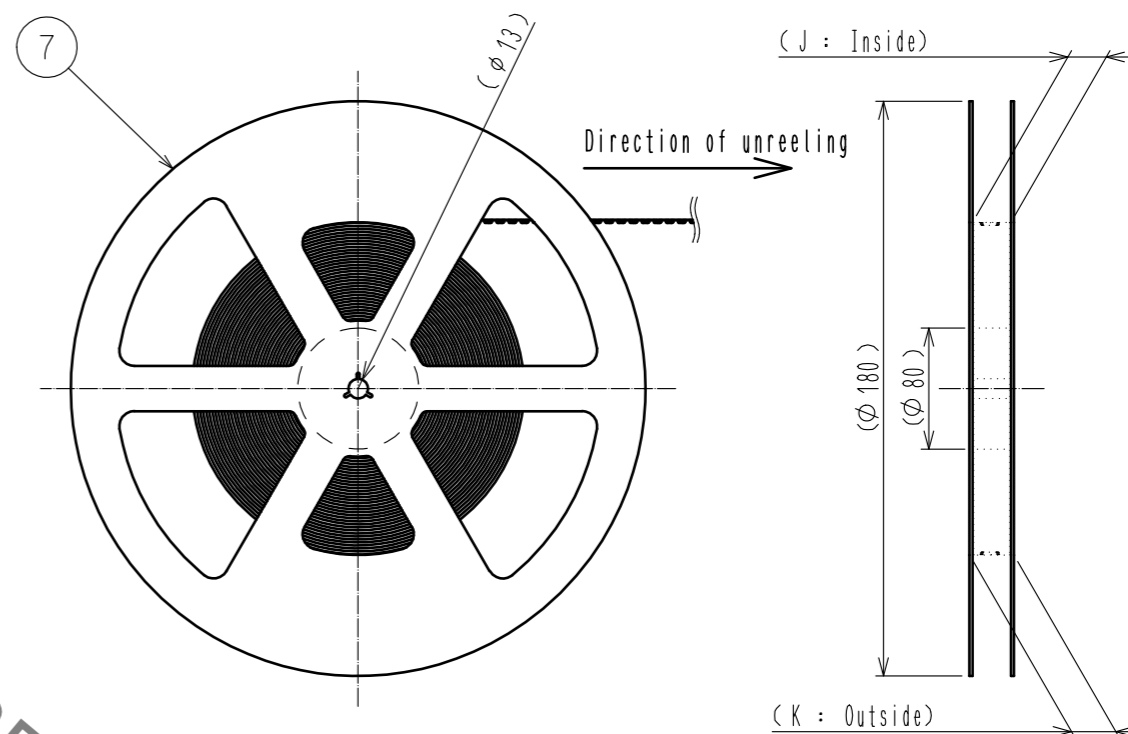

Leader, Trailer dimension (FREE)

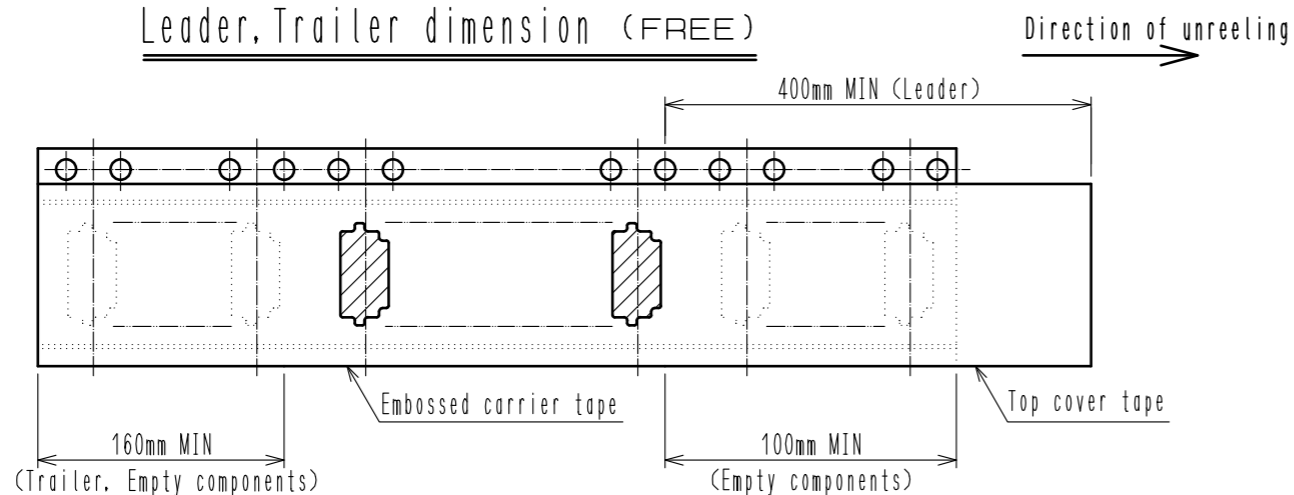

NOTES 11. Per reel : 500 connectors.
 12. Refer to JIS C 0806 and IEC60286-3.
 (Packaging of components for automatic handling.)

<Packing specification>

HRS	DRAWING NO.	EDC-382927-99-00
	PART NO.	FH72-**S-0.3SHW<99>
	CODE NO.	CL580

3/9

Jan.1.2022 Copyright 2022 HIROSE ELECTRIC CO., LTD. All Rights Reserved.
In case of consideration for using Automotive equipment / device which demand high reliability, kindly contact our sales window correspondents.

Part Number	Code Number	Number of Contacts	Dimension of connector, PCB mounting pattern, metal mask, FPC						Dimension of drawing for packing				
			A	B	C	D	E	F	G	H	J	K	L
FH72-7S-0.3SHW(99)	—	7	5.5	1.2	1.8	4.2	3.23	3.2	16	7.5	17.4	21.4	1.76
FH72-9S-0.3SHW(99)	—	9	6.1	1.8	2.4	4.8	3.83	3.8	16	7.5	17.4	21.4	2.36
FH72-11S-0.3SHW(99)	CL580-5100-0-99	11	6.7	2.4	3.0	5.4	4.43	4.4	24	11.5	25.4	29.4	2.96
FH72-13S-0.3SHW(99)	—	13	7.3	3.0	3.6	6.0	5.03	5.0	24	11.5	25.4	29.4	3.56
FH72-15S-0.3SHW(99)	—	15	7.9	3.6	4.2	6.6	5.63	5.6	24	11.5	25.4	29.4	4.16
FH72-17S-0.3SHW(99)	—	17	8.5	4.2	4.8	7.2	6.23	6.2	24	11.5	25.4	29.4	4.76
FH72-19S-0.3SHW(99)	—	19	9.1	4.8	5.4	7.8	6.83	6.8	24	11.5	25.4	29.4	5.36
FH72-21S-0.3SHW(99)	CL580-5101-0-99	21	9.7	5.4	6.0	8.4	7.43	7.4	24	11.5	25.4	29.4	5.96
FH72-23S-0.3SHW(99)	—	23	10.3	6.0	6.6	9.0	8.03	8.0	24	11.5	25.4	29.4	6.56
FH72-25S-0.3SHW(99)	—	25	10.9	6.6	7.2	9.6	8.63	8.6	24	11.5	25.4	29.4	7.16
FH72-27S-0.3SHW(99)	—	27	11.5	7.2	7.8	10.2	9.23	9.2	24	11.5	25.4	29.4	7.76
FH72-29S-0.3SHW(99)	—	29	12.1	7.8	8.4	10.8	9.83	9.8	24	11.5	25.4	29.4	8.36
FH72-31S-0.3SHW(99)	CL580-5102-0-99	31	12.7	8.4	9.0	11.4	10.43	10.4	24	11.5	25.4	29.4	8.96

※The products without code number are currently under planning.
Please contact HIROSE for detailed information about product variation.

<Dimension table>

HRS	DRAWING NO.	EDC-382927-99-00
	PART NO.	FH72-**S-0.3SHW(99)
	CODE NO.	CL580

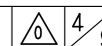

Jan.1.2022 Copyright 2022 HIROSE ELECTRIC CO., LTD. All Rights Reserved.
In case of consideration for using Automotive equipment / device which demand high reliability, kindly contact our sales window correspondents.

This connector features small and thin, requiring delicate and careful handling.
To prevent connector/FPC breakage and contact failure (mating failure, FPC pattern breakage, etc),
read through the instructions shown below and handle the connector properly.

[Connector Part Nomenclature]

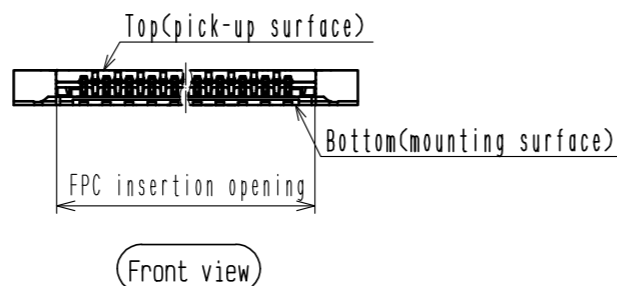
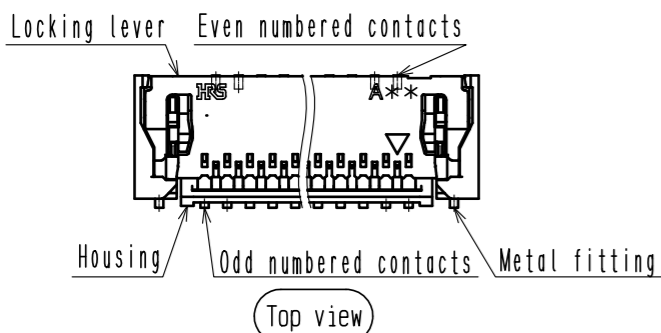

[Operation and precautions]

1. Initial condition

The product is supplied with the lock lever closed.
Locking lever does not have to be operated before inserting FPC.

[Caution]

- Do not open the locking lever when the FPC is not inserted.
The lock lever is to be used only when extracting the FPC (Example 1).
- Do not insert FPC or operate locking lever before mounting (Example 1).

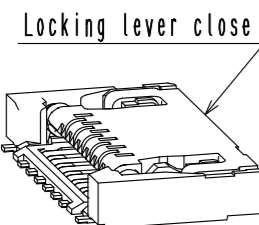

- When delivered -

Example 1)

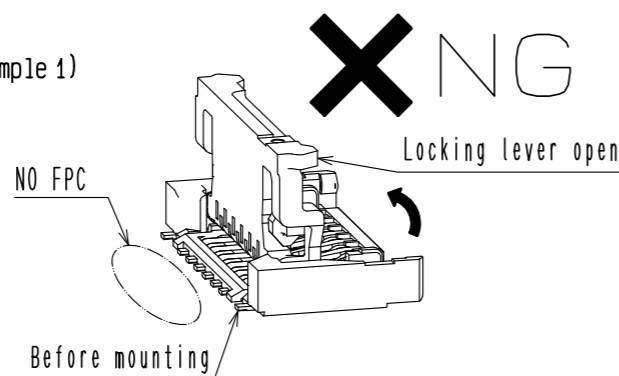

2. How to insert FPC

Insert the FPC into the connector opening horizontally to the PCB surface (Example 2).
Insert it properly to the very end.

[Caution]

- Make sure the lock lever is closed when inserting the FPC.
Do not insert the FPC when the lock lever is open (Example 3).
- Align both sides of FPC horizontally to the sides of the connector opening and insert straightforward.
- Do not twist the FPC to up and down or right and left or an angle (Example 4, 5).

Example 2)

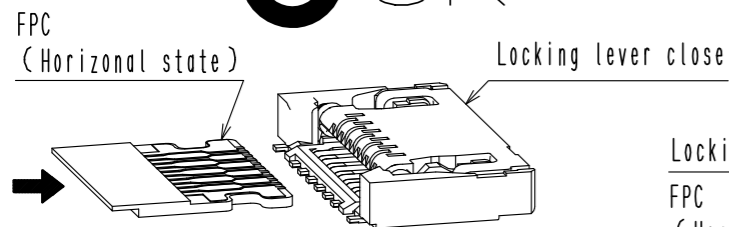

Locking lever close
FPC (Horizontal state)

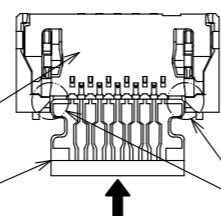

Align both sides of FPC horizontally to the sides of the connector opening and insert straightforward.

Example 3)

X NG

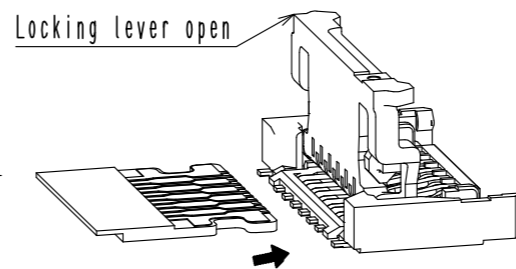

Example 4)

X NG

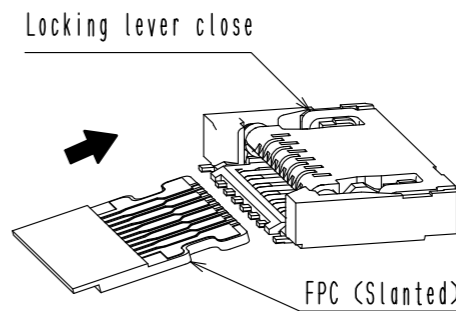

Example 5)

X NG

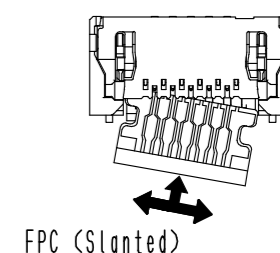

3. FPC insertion check

Make sure that the FPC is completely inserted to the end.
after FPC insertion (Example 6).
(The FPC position is to be aligned by the protrusion of the locking lever.)

[Caution]

- Do not insert the FPC at an angle and/or stop it before insertion is completed (Example 7, 8).
- As this product is designed for one action locking, the locking lever does not have to be operated after inserting FPC.

Example 6)

O OK

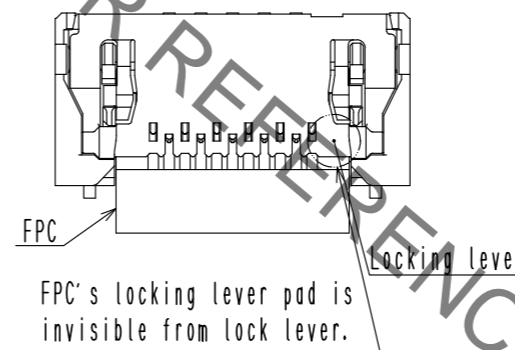

FPC's locking lever pad is invisible from lock lever.

Section - locking area -

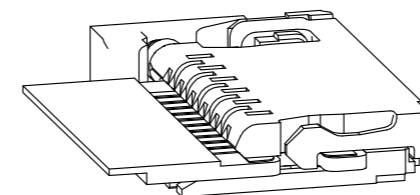

Example 7)

X NG

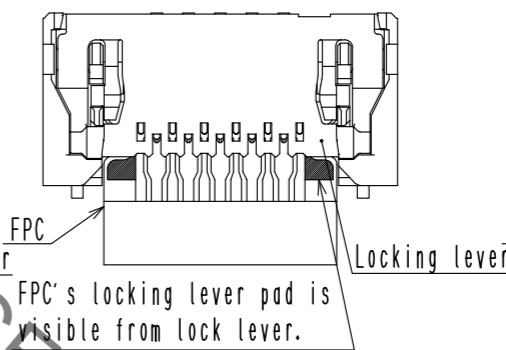

FPC's locking lever pad is visible from lock lever.

Section - locking area -

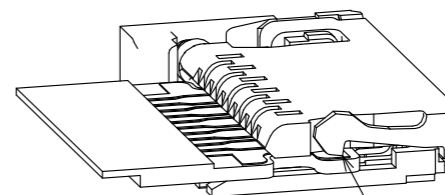

Locking Lever run on the FPC.

Example 8)

X NG

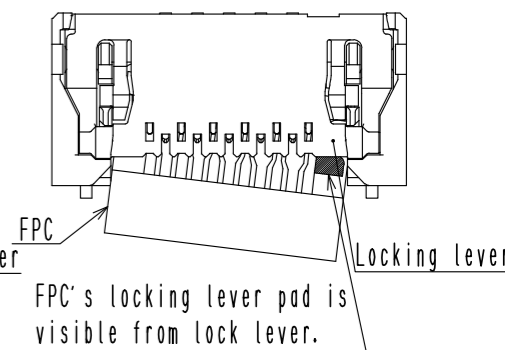

FPC's locking lever pad is visible from lock lever.

Section - locking area -

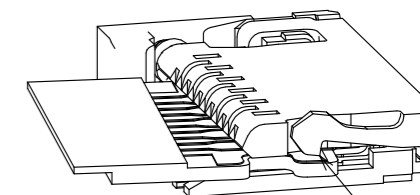

Locking Lever run on the FPC.

<Instruction manual(1)>

HRS	DRAWING NO.	EDC-382927-99-00
	PART NO.	FH72-**S-0.3SHW(99)
	CODE NO.	CL580
		5/9

Jan.1.2022 Copyright 2022 HIROSE ELECTRIC CO., LTD. All Rights Reserved.
In case of consideration for using Automotive equipment / device which demand high reliability, kindly contact our sales window correspondents.

4. How to release the lock
Slowly flip up the locking lever to release the lock (Example 9).

[Caution]

- To open the locking lever, operate at the center of the locking lever (Example 10).
- To open the locking lever, do not operate the locking lever at one end only (Example 11).
- The locking lever is opened up to the movable limit, 180 degree. Do not open the locking lever beyond the specified degree or apply excess force to the locking lever (Example 12).
- Do not touch contacts after the locking lever is opened (Example 13).
- Do not pick the locking lever to lift and pull it (Example 14).
- Operate the locking lever by hand without using sharp tool such as Tweezers. (Example 15).
- Do not apply excess force to the housing during the operation (Example 16).
- Do not try to open the lock lever from the FPC insertion side, as the lock lever is designed with the opposite direction from the FPC insertion direction (Example 17).

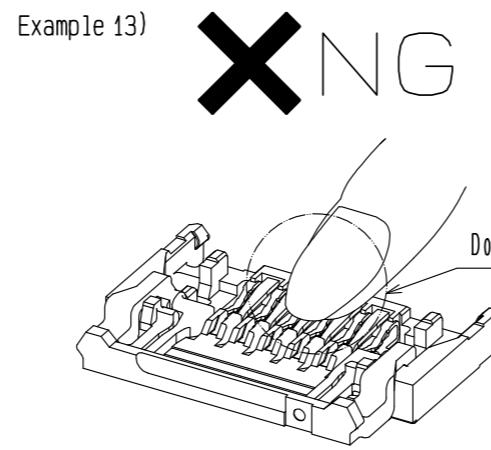
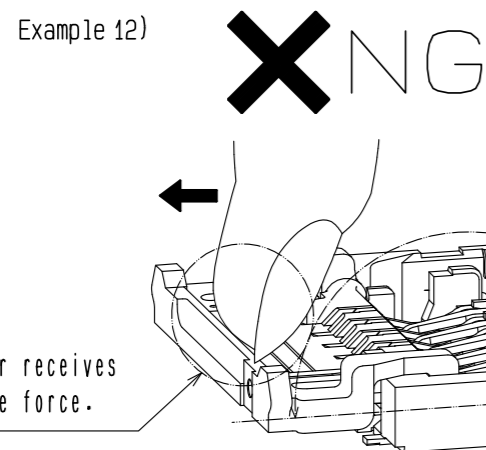
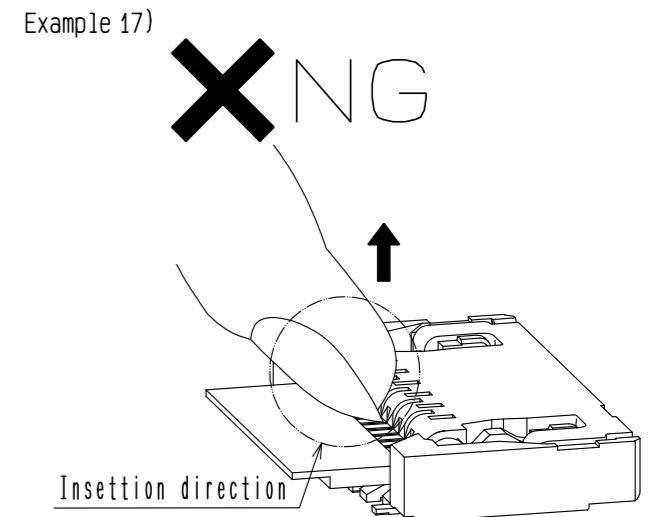
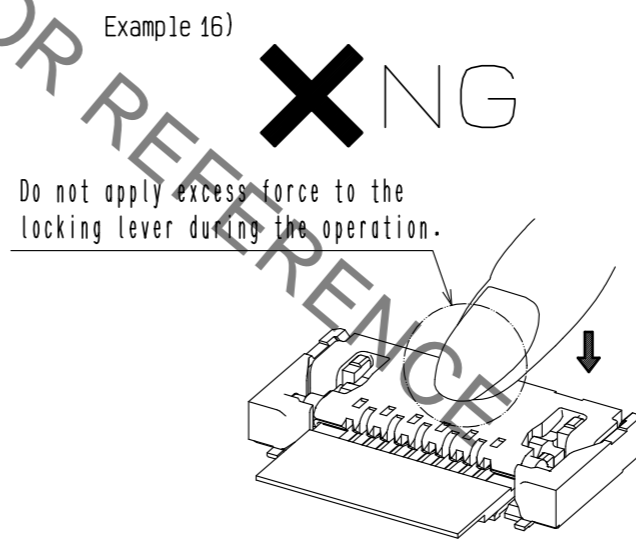
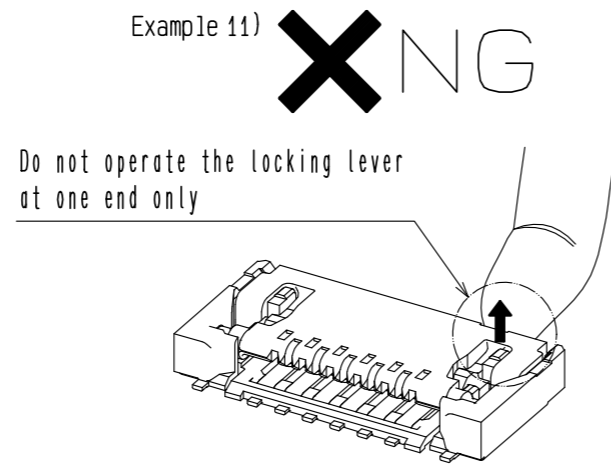
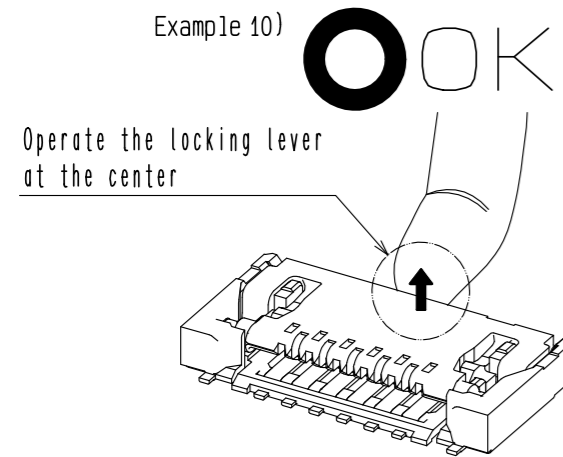
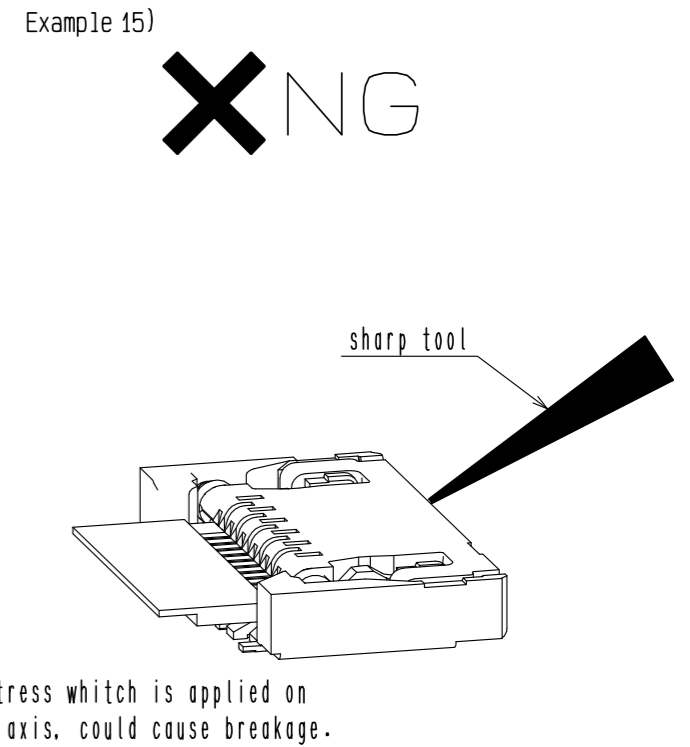
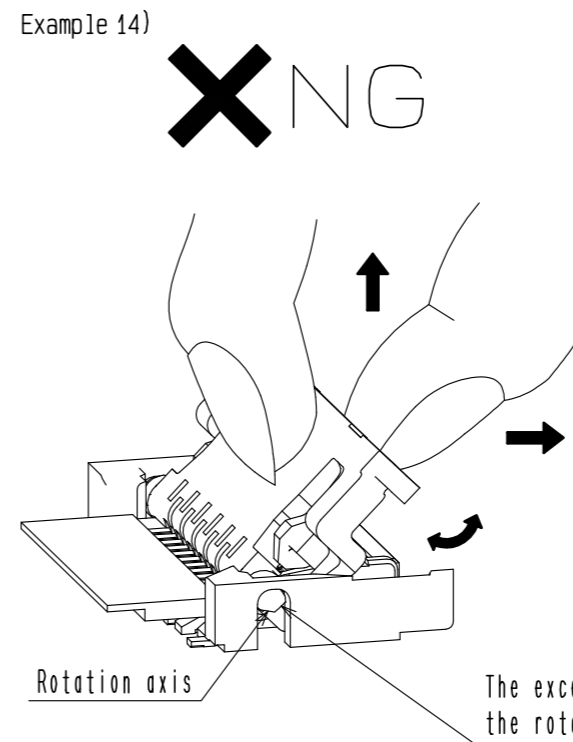
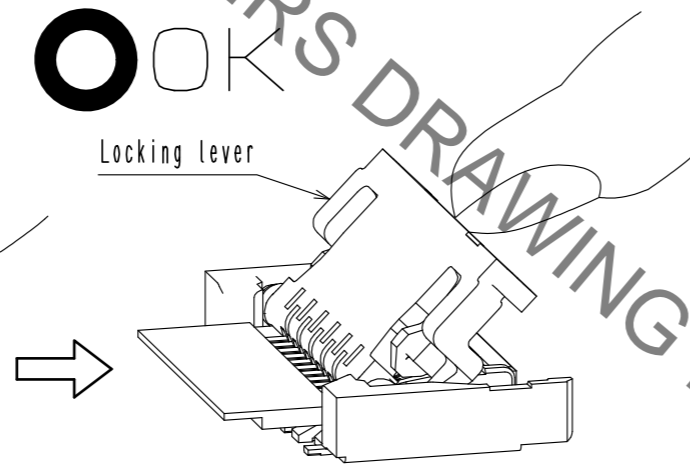
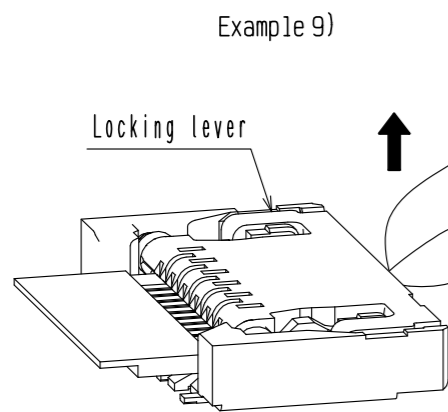

<Instruction manual(2)>

HRS	DRAWING NO.	EDC-382927-99-00
	PART NO.	FH72-**S-0.3SHW(99)
	CODE NO.	CL580
		6/9

Jan.1.2022 Copyright 2022 HIROSE ELECTRIC CO., LTD. All Rights Reserved.
In case of consideration for using Automotive equipment / device which demand high reliability, kindly contact our sales window correspondents.

5. How to remove FPC

After flip up the locking lever more than 45 degrees carefully withdraw the FPC (Example 18).
Close the locking lever after withdraw the FPC (Example 19).

[Caution]

- Do not attempt to pull the FPC when the locking lever is less than 45 degrees (Example 20).
- This connector has a temporary FPC holding structure with the locking lever.
For FPC removal, do not pull out the FPC upward or angled direction (Example 21).
- Close the both ends of the locking lever (Example 22).

Example 18)

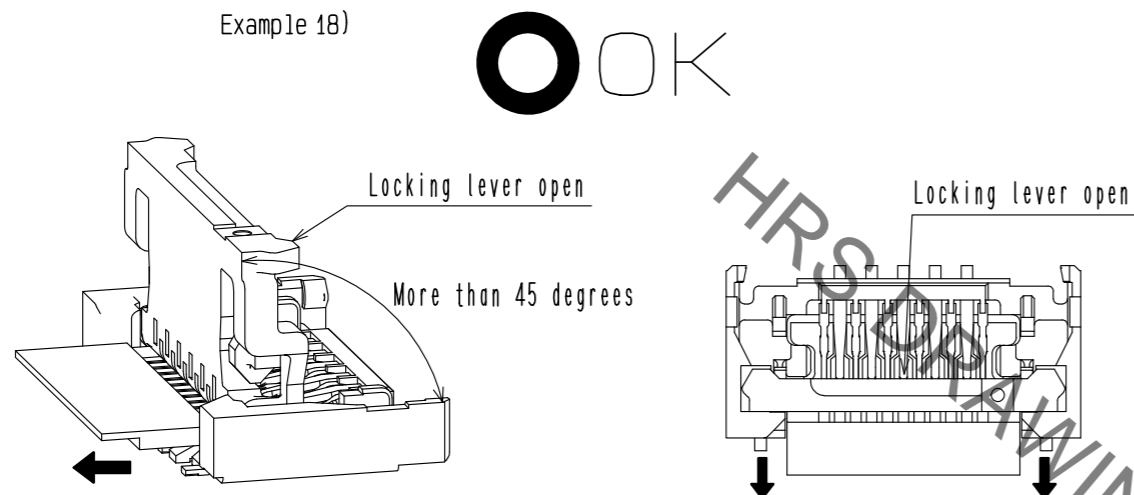

Example 20)
Section - locking area -

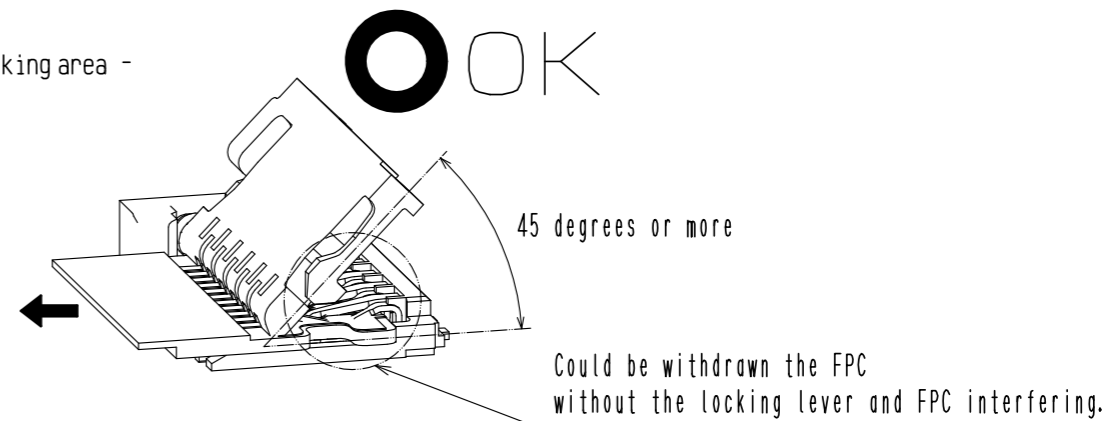

Locking lever close

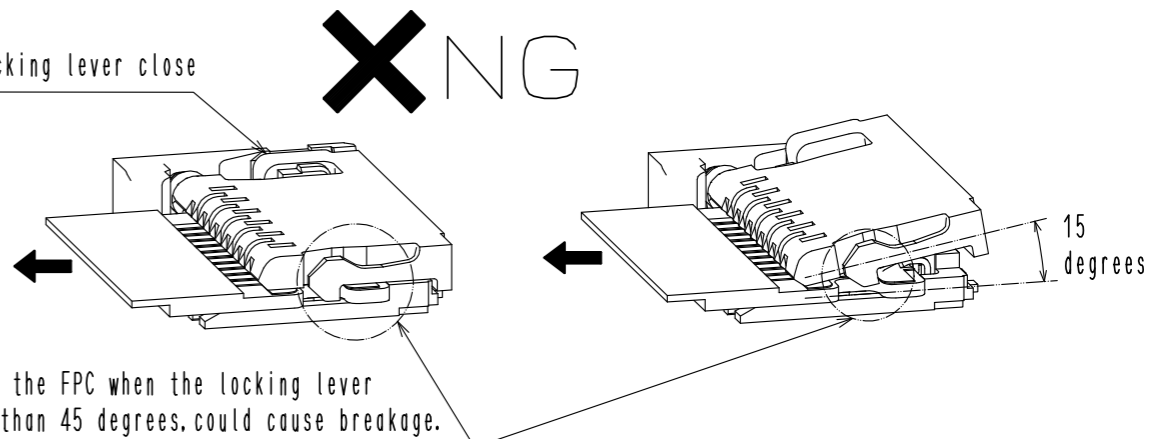

Example 21)

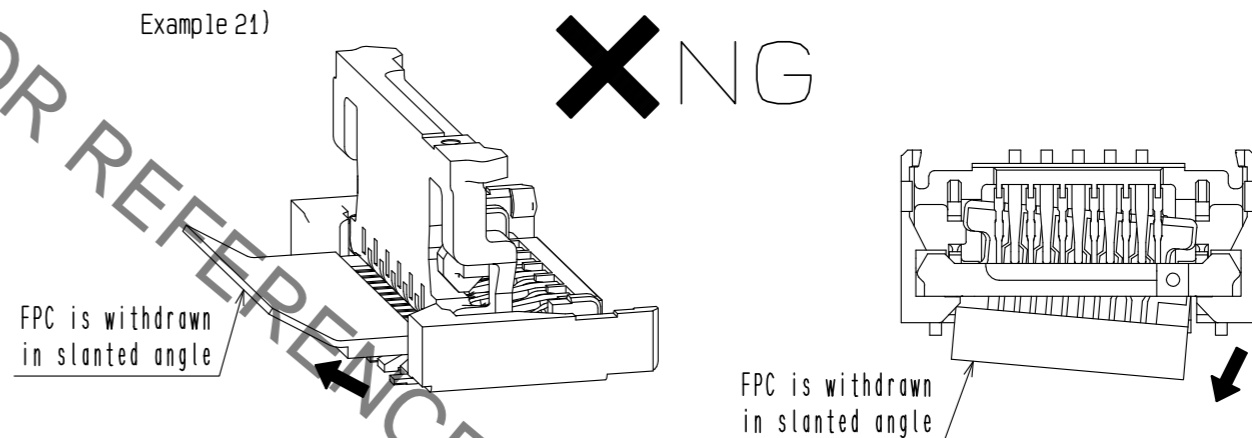

Example 22)

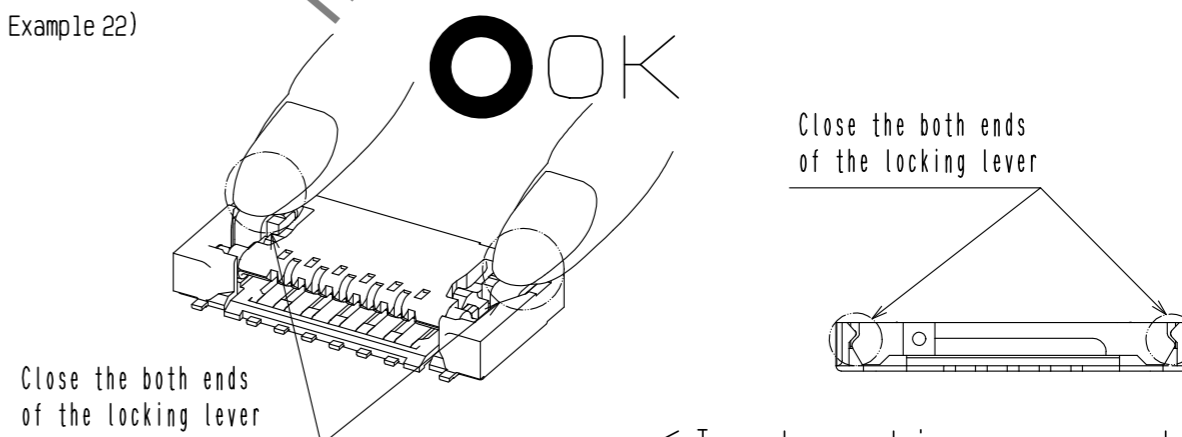

<Instruction manual(3)>

HRS	DRAWING NO.	EDC-382927-99-00
	PART NO.	FH72-**S-0.3SHW(99)
	CODE NO.	CL580
		7/9

Jan.1.2022 Copyright 2022 HIROSE ELECTRIC CO., LTD. All Rights Reserved.
In case of consideration for using Automotive equipment / device which demand high reliability, kindly contact our sales window correspondents.

[Precautions for component layout]

Depending on a FPC rounding, a load is applied to the connector, and a contact failure may occur. To prevent a failure, take the following notes into a consideration during mechanism design.

[Caution]

- When fixing FPC after FPC cabling, avoid pulling FPC, and route the wire FPC with slack. In this regard, the stiffener is parallel to the PCB (Example 23).
- Avoid applying forces to FPC in vertical or horizontal directions. Do not bend the FPC excessively near the connector during use, or it may cause contact failure or FPC breakage. Stabilizing the FPC is recommended (Example 24, 25).
- Do not mount other components touching to the FPC underneath the FPC stiffener (Example 26).
- Make adjustments with the FPC manufacturer for FPC bending performance and wire breakage.
- Keep a sufficient FPC insertion space in the stage of the layout in order to avoid incorrect FPC insertion. Appropriate FPC length and component layout are recommended for assembly ease. Too short FPC length makes assembly difficult.
- Keep spaces for the locking lever movement and its operation for PCB design and component layout.

Example 23)

OK

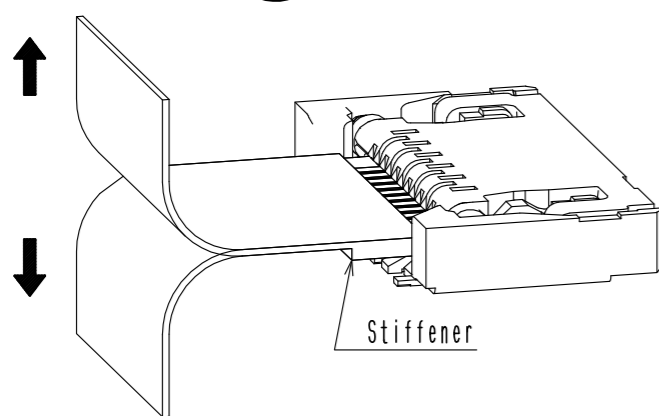

Example 24)

NG

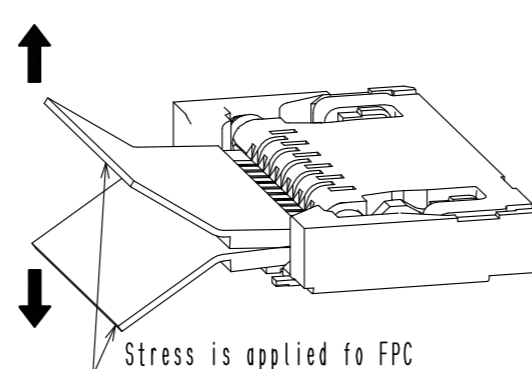

Example 25)

NG

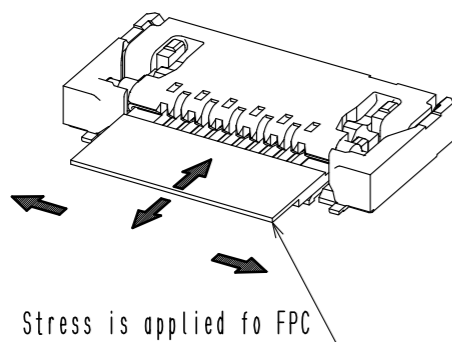

Example 26)

NG

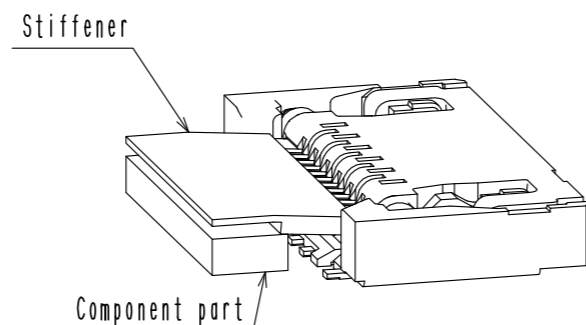

[Instructions for mounting on the PCB]

Follow the instructions shown below when mounting on the PCB.

[Caution]

- Refer to recommended layouts on the page 1 for PCB and stencil pattern.
- Shorter pattern width than the recommended PCB dimension, could cause solder wicking and/or flux penetration.
- Larger pattern than the recommended stencil dimension, could cause solder wicking and/or flux penetration.
- Clearance underneath the contact lead and the housing is very small. In case solder resist and/or silk screening are applied on PCB underneath the connector, verify the thickness, or it could push up the connector bottom and may cause soldering defect and/or insufficient fillet formation.
- Apply reflow temperature profile within the specified conditions. In individual applications, the actual temperature may vary depending on solder paste type, volume/thickness and PCB size/thickness. Consult your solder paste and equipment manufacturer for specific recommendations.
- Prevent warpage of PCB, where possible, since it can cause soldering failure even with 0.1 mm max coplanarity.
- When mounting on the flexible board, please make sure to put a stiffener on the backside of the flexible board. We recommend a glass epoxy material with the thickness of 0.3 mm min.
- Do not add 1.0 N or greater external force when unreel or pick and place the connector etc. or it may get broken.

[Instructions for PCB handling after mounting the connector]

Follow the instructions shown below when mounting on the PCB.

[Caution]

- Splitting a large PCB into several pieces
 - Screwing the PCB
- During the handling described above, do not exert an excessive force on the PCB. Otherwise, the connector may become defective.
- The warp of a 100 mm wide PCB should be 1.0 mm or less.
- The warp of PCB suffers stress on connector and the connector may become defective (Example 27).

Example 27)

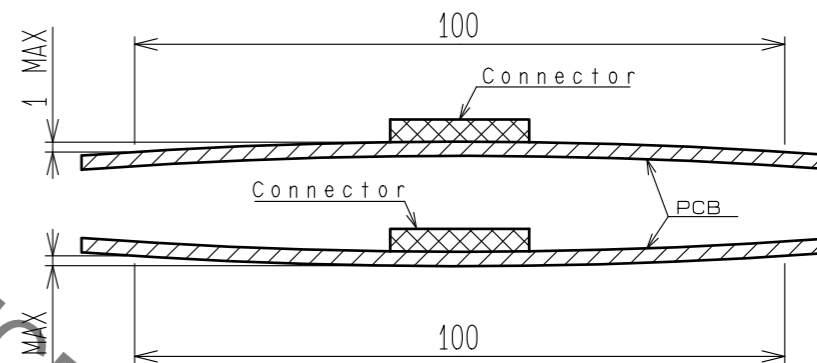

[Instructions on manual soldering]

Follow the instructions shown below when soldering the connector manually during repair work, etc.

[Caution]

- Do not perform manual soldering with the FPC inserted into the connector.
- Do not heat the connector excessively. Be very careful not to let the soldering iron contact any parts other than connector leads. Otherwise, the connector may be deformed or melt.
- Do not supply excessive solder (or flux). If excessive solder (or flux) is supplied on the terminals, solder or flux may adhere to the contacts, resulting in poor contact.

<Instruction manual(4)>

HRS	DRAWING NO.	EDC-382927-99-00
	PART NO.	FH72-**S-0.3SHW(99)
	CODE NO.	CL580
		8/9

Jan.1.2022 Copyright 2022 HIROSE ELECTRIC CO., LTD. All Rights Reserved.
In case of consideration for using Automotive equipment / device which demand high reliability, kindly contact our sales window correspondents.

[Recommended reflow temperature profile]

The temperatures mentioned above refer to the PCB surface temperature near the connector leads.
In individual applications the actual temperature may vary, depending on solder paste type, volume/thickness and board size/thickness.
Consult your solder paste and equipment manufacturer for specific recommendations.

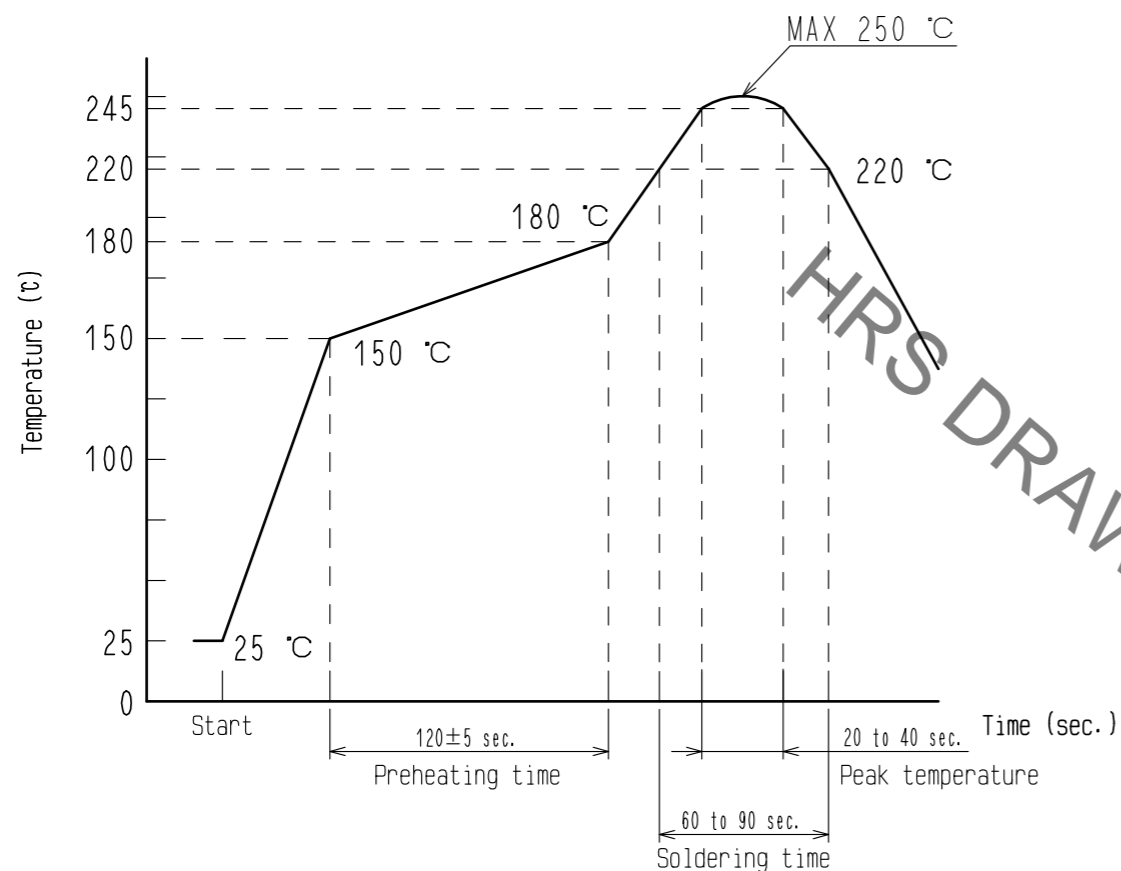

Reflow method: IR reflow
Number of reflow cycles: 2 cycles MAX.
1) Reflow time
Duration above 220°C: 60 to 90 sec MAX.
(Peak temperature: 250°C, 20 to 40 sec MAX.)
2) Pre-heat time
Pre-heat temperature (MIN): 150°C
Pre-heat temperature (MAX): 180°C
Pre-heat time: 120 ± 5 sec.

<Recommended reflow temperature profile>

HRS	DRAWING NO.	EDC-382927-99-00
	PART NO.	FH72-**S-0.3SHW(99)
	CODE NO.	CL580

