

FEATURES

1. Ultra-wide 4:1 input voltage range
2. High efficiency up to 89%
3. No-load power consumption as low as 0.12W
4. I/O isolation test voltage 3kVDC
5. Operating ambient temperature range: -40°C to +85°C
6. Input under-voltage protection, output short-circuit, over-voltage, over-current protection
7. CISPR32/EN55032CLASSAEMI compliant without external components
8. Industry standard pin-out



3 years
Warranty

Selection Guide

Part No.	Input Voltage (VDC)		Output		Full Load Efficiency(%) Min./Typ.	Capacitive Load (µF)Max.
	Nominal (Range)	Max.	Voltage (VDC)	Current (mA) (Max./Min.)		
ZYF2405LP-20WR3	24 (9-36)	40	5	4000/0	87/89	10000
ZYF2412LP-20WR3			12	1667/0	86/88	1600
ZYF2415LP-20WR3			15	1334/0	87/89	1000
ZYF2424LP-20WR3			24	833/0	87/89	500
ZYF4805LP-20WR3	48 (18-75)	80	5	4000/0	86/88	10000
ZYF4812LP-20WR3			12	1667/0	86/88	1600
ZYF4815LP-20WR3			15	1334/0	87/89	1000
ZYF4824LP-20WR3			24	833/0	87/89	500

Input Specifications

Item	Operating Conditions		Min.	Typ.	Max.	Unit
Input Current (full load/no-load)	24VDC input	3.3V output	--	799/40	819/45	mA
		5V output	--	936/40	958/45	
		Other output	--	947/10	969/20	
Input Current (full load/no-load)	48VDC input	3.3V output	--	400/20	410/25	mA
		5V output	--	473/20	485/25	
		Other output	--	473/5	485/8	
Reflected Ripple Current	24VDC input		--	30	--	
	48VDC input		--	30	--	
Surge Voltage (1sec. max.)	24VDC input		-0.7	--	50	VDC
	48VDC input		-0.7	--	100	
	24VDC input		--	--	9	

Start-up Voltage	48VDC input	--	--	18	
Input Under-voltage Protection	24VDC input	5.5	6.5	--	
	48VDC input	12.0	15.5	--	
Start-up Time	Nominal input& constant resistance load	--	10	--	ms
Input Filter		Pi filter			
Hot Plug		Unavailable			
Ctrl*	Module on	Ctrl pin open or pulled high (3.5-12VDC)			
	Module off	Ctrl pin pulled low to GND (0-1.2VDC)			
	Input current when off	--	4	7	mA
Note: *The Ctrl pin voltage is referenced to input GND.					

Output Specifications

Item	Operating Conditions	Min.	Typ.	Max.	Unit	
Voltage Accuracy	0%-100% load	--	±1	±3	%	
Linear Regulation	Input voltage variation from low to high at full load	--	±0.2	±0.5		
Load Regulation	0%-100% load	--	±0.5	±1		
Transient Recovery Time	25% load step change, nominal input voltage	--	300	500	µs	
Transient Response Deviation		3.3V, 5V output	--	±5	±8	%
		Others	--	±3	±5	
Temperature Coefficient	Full load	--	--	±0.03	%/°C	
Ripple & Noise*	20MHz bandwidth, 5%-100% load	--	50	100	mV p-p	
Over-voltage Protection	Input voltage range	110	--	160	%Vo	
Trim		90	--	110		
Over-current Protection		110	--	190		%Io
Short-circuit Protection		Hiccup, continuous, self-recovery				
Note: *Under 0% -5% load conditions, ripple & noise does not exceed 5%Vo. The "parallel cable" method is used for ripple and noise test, please refer to DC-DC Converter Application Notes for specific information.						

General Specifications

Item	Operating Conditions	Min.	Typ.	Max.	Unit
Isolation	Input-output Electric Strength test for 1 minute with a leakage current of 1mA max.	3000	--	--	VDC
Insulation Resistance	Input-output insulation at 500VDC	1000	--	--	MΩ
Isolation Capacitance	Input-output capacitance at 100kHz/0.1V	--	500	--	pF
Operating Temperature	See Fig. 1	-40	--	+85	°C
Storage Temperature		-55	--	+125	
Storage Humidity	Non-condensing	5	--	95	%RH
Pin Soldering Resistance Temperature	Soldering spot is 1.5mm away from case for 10 seconds	--	--	+300	°C
Vibration		10-55Hz, 2G, 30 Min. along X, Y and Z			
Switching Frequency *	PWM mode	--	270	--	kHz
MTBF	MIL-HDBK-217F@25°C	1000	--	--	k hours

Note:*Switching frequency is measured at full load. The module reduces the switching frequency for light load (below 50%) efficiency improvement.

Mechanical Specifications

Case Material	Black plastic; flame-retardant and heat-resistant (UL94 V-0)
Dimensions	51.50 × 26.50 × 12.00 mm
Weight	23.7g (Typ.)
Cooling Method	Free air convection

EMC Specifications

Emissions	CE	CISPR32/EN55032	CLASS A (without extra components)/CLASS B (see Fig.3-② for recommended circuit)	
	RE	CISPR32/EN55032	CLASS A (without extra components)/CLASS B (see Fig.3-②)	for recommended circuit)
Immunity	ESD	IEC/EN61000-4-2	Contact ±4kV	perf. Criteria B
	RS	IEC/EN61000-4-3	10V/m	perf. Criteria A
	EFT	IEC/EN61000-4-4	±2kV (see Fig.3-① for recommended circuit)	perf. Criteria B
	Surge	IEC/EN61000-4-5	line to line ±2kV (see Fig.3-① for recommended circuit)	perf. Criteria B
	CS	IEC/EN61000-4-6	3 Vr.m.s	perf. Criteria A
	Voltage dips, short interruptions and voltage variations immunity	IEC/EN61000-4-29	0%, 70%	perf. Criteria B

Typical Characteristic Curves

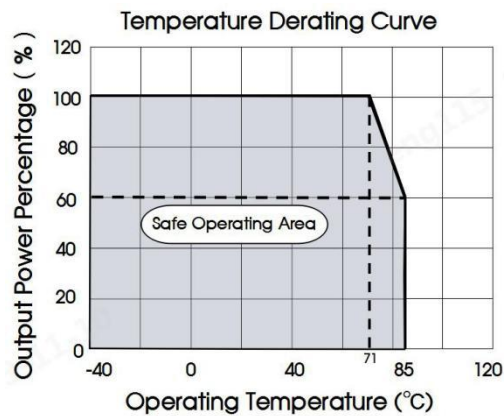
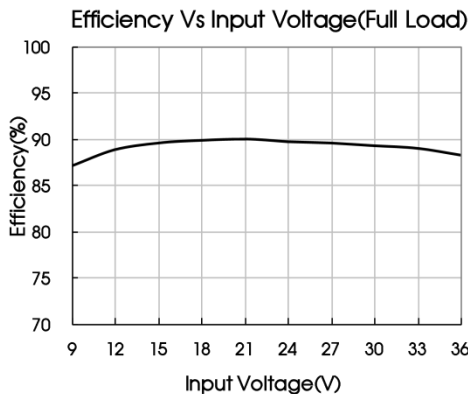
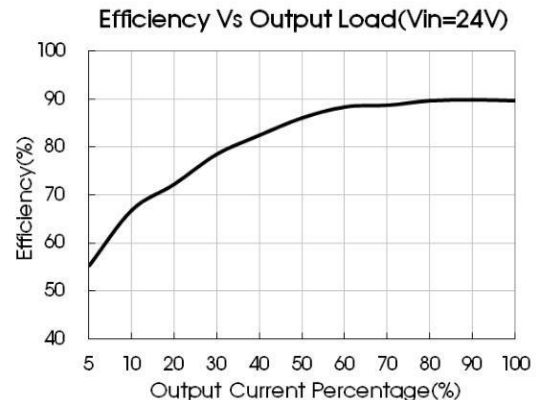

Fig. 1



ZYF2405LP-20WR3



ZYF2405LP-20WR3

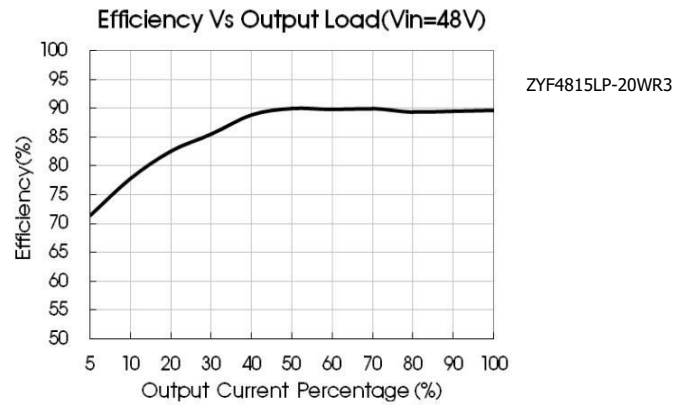
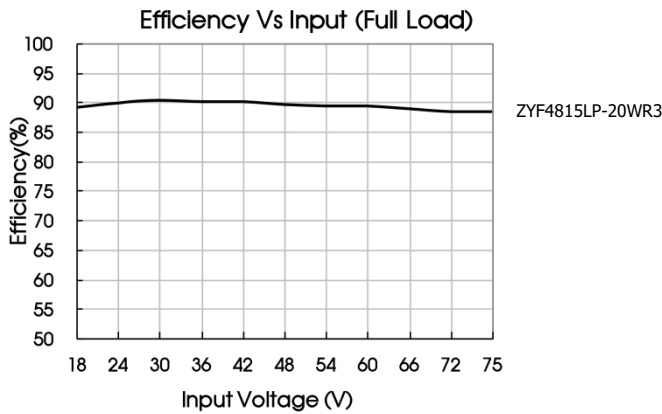

Circuit Design and Application

1. Typical application

All the DC/DC converters of this series are tested before delivery using the recommended circuit shown in Fig. 2.

Input and/or output ripple can be further reduced by appropriately increasing the input & output capacitor values C_{in} and C_{out} and/or by selecting capacitors with a low ESR (equivalent series resistance). Also make sure that the capacitance is not exceeding the specified max. capacitive load value of the product.

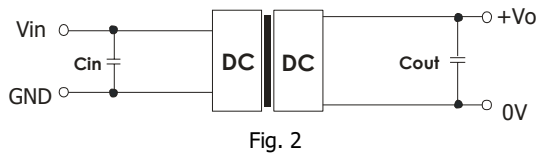

Vout(VDC)	Cin	Cout
3.3/5	100 μ F/100V	470 μ F/15V
9/12/15		220 μ F/25V
18/24		100 μ F/50V

2. EMC compliance circuit

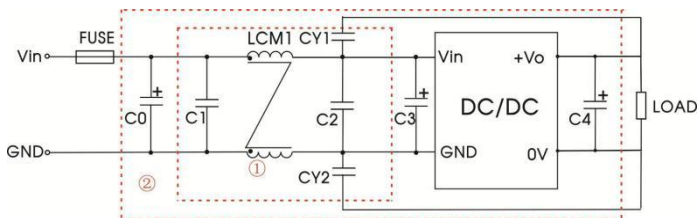

Fig. 3

Notes: For EMC tests we use Part ② in Fig. 3 for immunity and part ① for emissions test. Selecting based on needs.

Parameter description

Model	Vin: 24VDC	Vin: 48VDC
FUSE	Choose according to actual input current	
C0	1000 μ F/50V	680 μ F/100V
C1/C2	1 μ F/50V	1 μ F/100V
C3	330 μ F/50V	330 μ F/100V
C4	Refer to the Cout in Fig.2	
LCM1	6.8mH	
CY1, CY2	1nF/3kV	

3. Trim Function for Output Voltage Adjustment (open if unused)

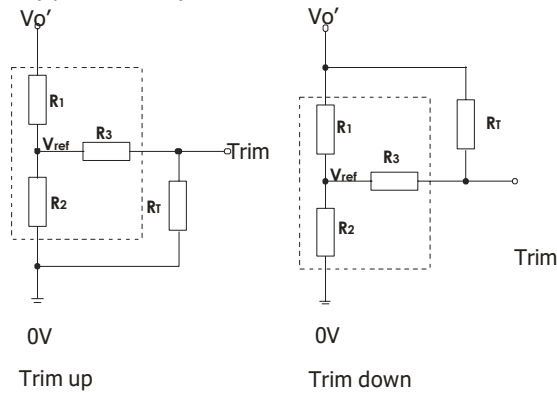

TRIM resistor connection (dashed line shows internal resistor network)

Trim resistor calculation

$$\begin{aligned} \text{up: } R_T &= \frac{\alpha R_2}{R_2 - \alpha} - R_3 & \alpha &= \frac{V_{ref}}{V_{o'} - V_{ref}} \cdot R_1 \\ \text{down: } R_T &= \frac{\alpha R_1}{R_1 - \alpha} - R_3 & \alpha &= \frac{V_{o'} - V_{ref}}{V_{ref}} \cdot R_2 \end{aligned}$$

R_T = Trim Resistor value;
 α = self-defined parameter;
 $V_{o'}$ = desired output voltage.

Vout(V)	R1(kΩ)	R2(kΩ)	R3(kΩ)	Vref(V)
5	2.883	2.87	10	2.5
12	11.000	2.87	15	2.5
15	14.494	2.87	15	2.5
24	24.872	2.87	17.8	2.5

4. The products do not support parallel connection of their output

Dimensions and Recommended Layout

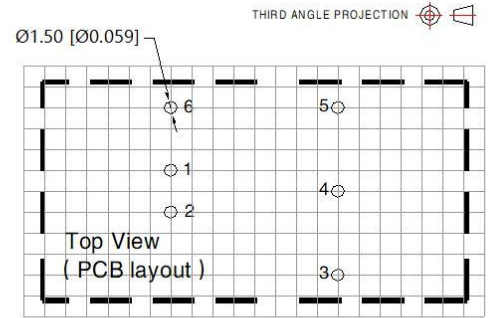
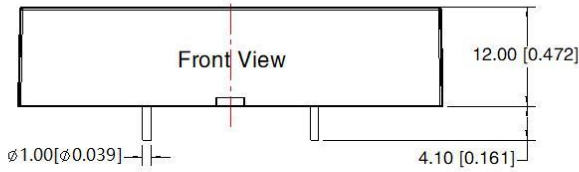

Note: Grid 2.54*2.54mm

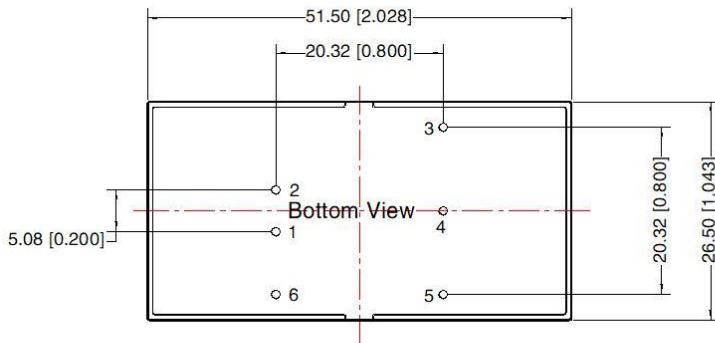

Note:
 Unit: mm[inch]
 Pin diameter tolerances: $\pm 0.10 [\pm 0.004]$
 General tolerances: $\pm 0.50 [\pm 0.020]$

Pin-Out	
Pin	Mark
1	GND
2	Vin
3	+Vo
4	Trim
5	0V
6	Ctrl

Note:

1. If the product works under the minimum required load, it cannot guarantee that the performance of the product complies with all the performance indicators in this manual;
2. The maximum capacitive load is tested under the input voltage range and full load condition;
3. Unless otherwise stated, all indexes in this manual are measured at $T_a=25^\circ\text{C}$, humidity $<75\%RH$, nominal input voltage and rated output load;
4. All index testing methods in this manual are based on the enterprise standards of the company;
5. Our company can provide product customization, specific needs can directly contact our technical staff.