

 福瑞达 深圳市福瑞达显示技术有限公司 SHENZHEN FRIDA LCD CO.,LTD	Doc.No.: FRD500H40119-A-CT2K	
	REV: A	PAGE: 1/20
SPEC TITLE DOCUMENT CONTROL SPECIFICATION	EFFECTIVE DATE: 2025-12-03	

PRODUCT SPECIFICATION

TFT-LCD MODULE

Model No: FRD500H40119-A-CT2K

For Customer's Acceptance	
Approved by	Comment

	Signature	Date
Prepared by	田 乐	2025.12.02
Checked by	朱 涛	2025.12.02
Approved by	汪 进	2025.12.03

深圳市福瑞达显示技术有限公司

工厂地址: 深圳市光明新区公明田寮第二工业区田荣路 68 号

Manufacturing base: The 68th, Tianrong Road, Tianliao Community, Gongming town, Guangming District, Shenzhen, China.

总部地址: 深圳市光明区光明大道云创谷园区 2 栋 18 楼

Headquarters: 18th Floor, 2nd Building, Yunchuang Valley Park, Guangming Avenue, Guangming District, Shenzhen, China.

电话(Tel): 0755-23422110

网址(Web): www.fridalcd.com

sales@fridalcd.com



Contents

No.	ITEM
1	Document Revision History
2	General Description
3	Outline Dimension
4	Interface Specification
5	Absolute Maximum Ratings
6	Electrical Specifications
7	Timing Characteristics
8	Power Supply Configuration
9	Optical Specification
10	Inspection Specifications
11	Reliability Test Items
12	Precautions

1. Document Revision History :

DOCUMENT REVISION	DATE	DESCRIPTION	PREPARED BY
A	2025-12-03	First Release.	TL



2. General Description

No	Item	Specification	Remark
1	Screen Size	5.0 inch	
2	Display Mode	Normally Black	
3	Resolution	800 × RGB × 480	
4	Active Area	108.0*64.8	mm
5	Outline Dimension	129.00*86.00*4.98	mm
6	Viewing Direction	ALL	
7	Driver IC	ST7262-G4-1-H	
8	Interface	RGB24bit	
9	Back Light	White Led*18	
10	Touch Panel	With CTP	



3. Outline Dimension

3.1 LCM+TP

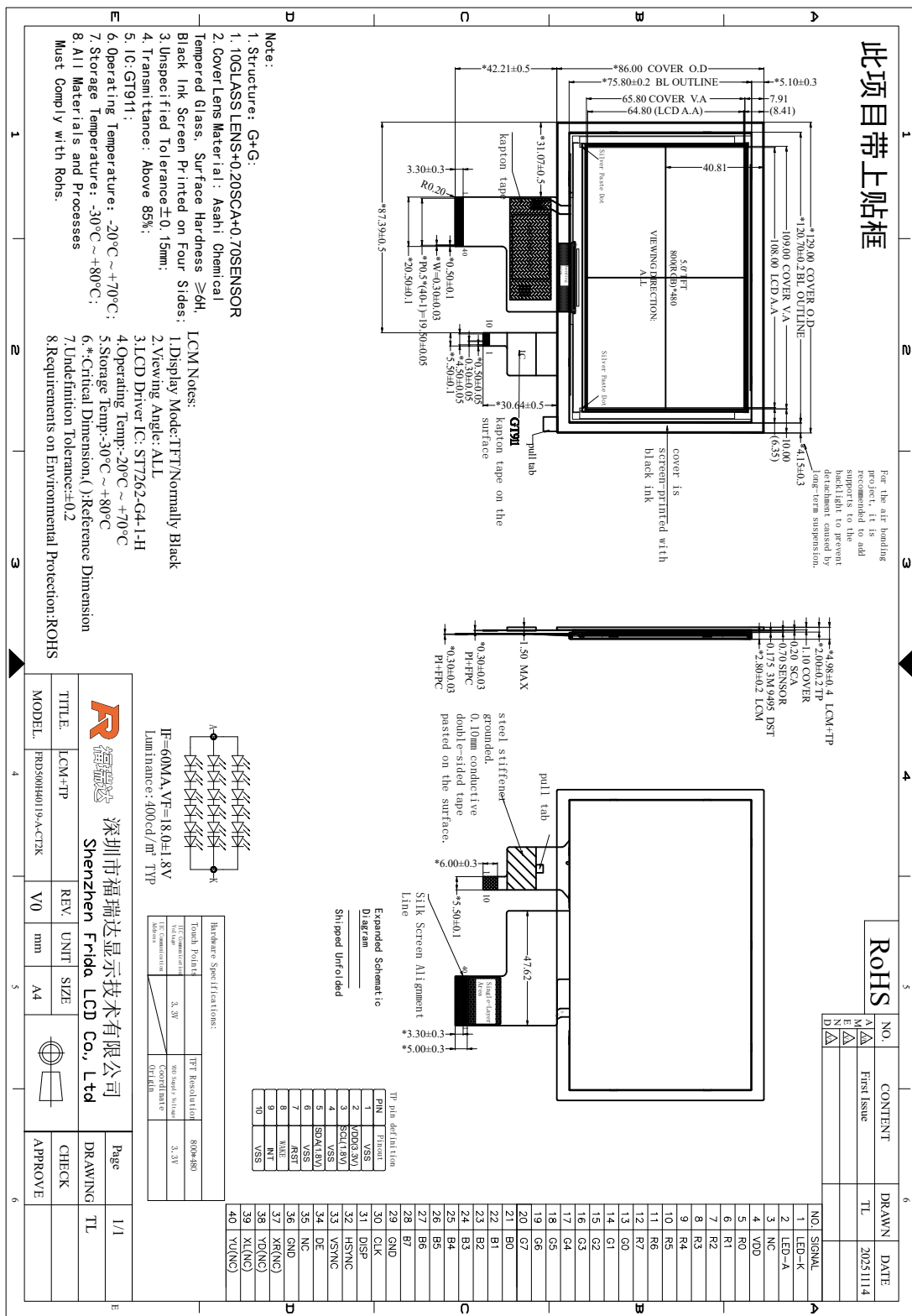

3.2 LCM

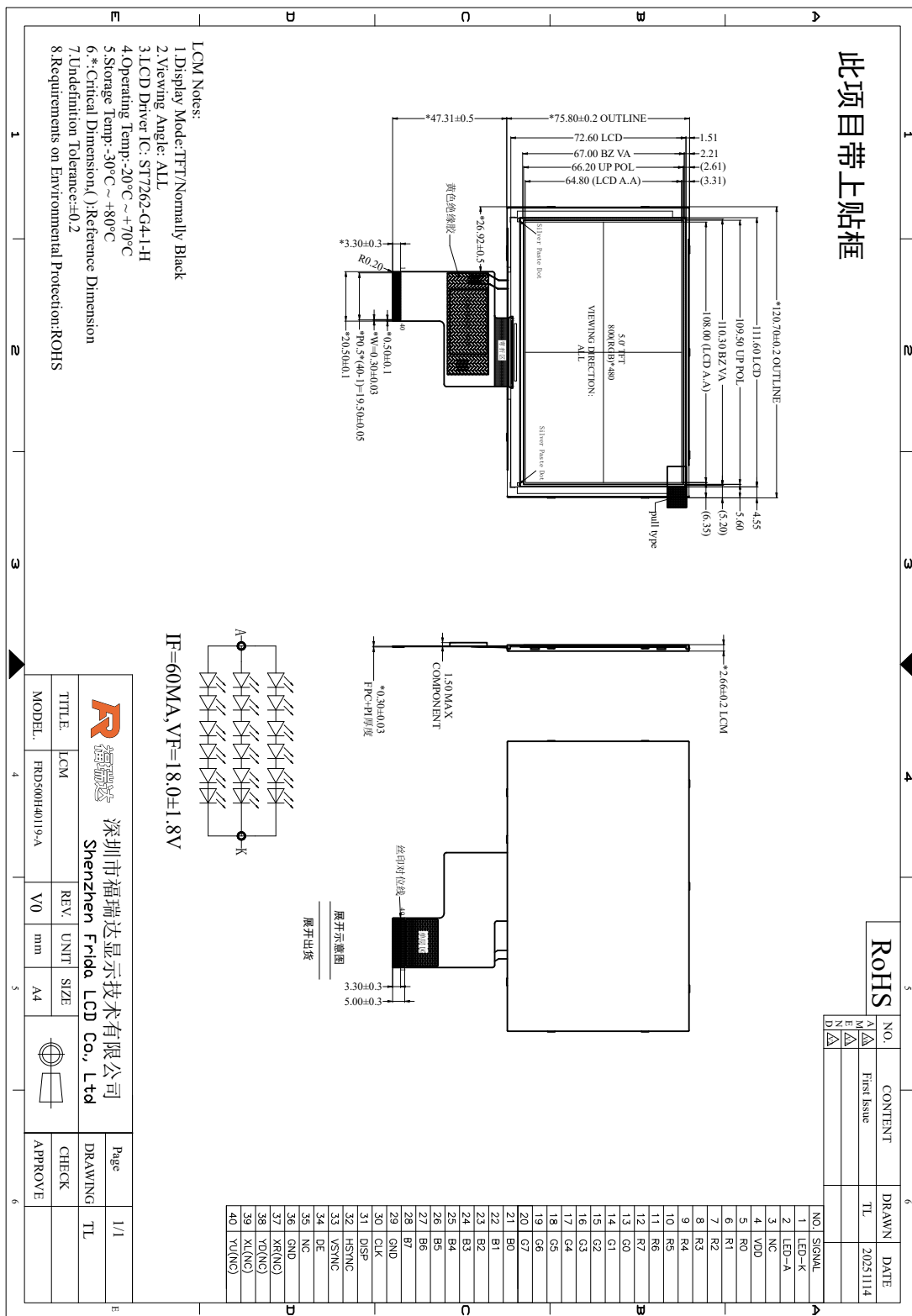



4. Interface Specification

4.1 LCM Interface Specification

Pin No	Symbol	Description	Note
1	LED-K	Power Supply For LED Backlight Cathode Input.	
2	LED-A	Power Supply For LED Backlight Anode Input.	
3	NC	No Connection.	
4	VDD	Power Supply For LCD.	
5-12	R0-R7	Red data (R0-LSB;R7-MSB)	
13-20	G0-G7	Green data (G0-LSB; G7-MSB)	
21-28	B0-B7	Blue data (B0-LSB;B7-MSB)	
29	GND	Ground.	
30	CLK	Dot clock signal for RGB interface operation.	
31	DISP	DISP sets the display mode.	Note1
32	HSYNC	Line synchronous signal for RGB interface operation.	
33	VSYNC	Frame synchronous signal for RGB interface operation.	
34	DE	Data enable signal for RGB interface operation.	
35	NC	No Connection.	
36	GND	Ground.	
37	XR (NC)	Touch panel right side (No Connection.)	
38	YD (NC)	Touch panel down side (No Connection.)	
39	XL (NC)	Touch panel left side (No Connection.)	
40	YU (NC)	Touch panel up side (No Connection.)	

4.2 CTP Interface Specification

Pin No	Symbol	Description	Note
1	VSS	Ground.	
2	VDD (3.3V)	Power Supply for CTP.	
3	SCL(1.8V)	IIC clock signal pin for CTP.	
4	VSS	Ground.	
5	SDA(1.8V)	IIC data input/output pin for CTP.	
6	VSS	Ground.	



SPEC TITLE

DOCUMENT CONTROL SPECIFICATION

EFFECTIVE DATE: 2025-12-03

7	RST	Reset Signal input pin for CTP.	
8	WAKE	No Connection.	
9	INT	CTP interrupt request.	
10	VSS	Ground.	

Note1:

DISP	Function Description
L	Standby mode
H	Normal display mode

5. Absolute Maximum Ratings

Electrical Maximum Ratings – for IC Only

Parameter	Symbol	Min.	Max.	Unit	Note
Power supply voltage (VDD)	VDD	-0.3	+4.0	V	1

Note:

- 1.VDD,GND must be maintained.
- 2.The modules may be destroyed if they are used beyond the absolute maximum ratings.

6. Electrical Specifications

Parameter	Symbol	Conditions	Min.	Typ.	Max.	Unit
Power supply voltage(Analog)	VDD-GND		3.3	-	3.6	V
Supply voltage of white LED backlight	VLED	Forward current =60mA Number of LED = 18	16.2	18.0	19.8	V

7. Timing Characteristics

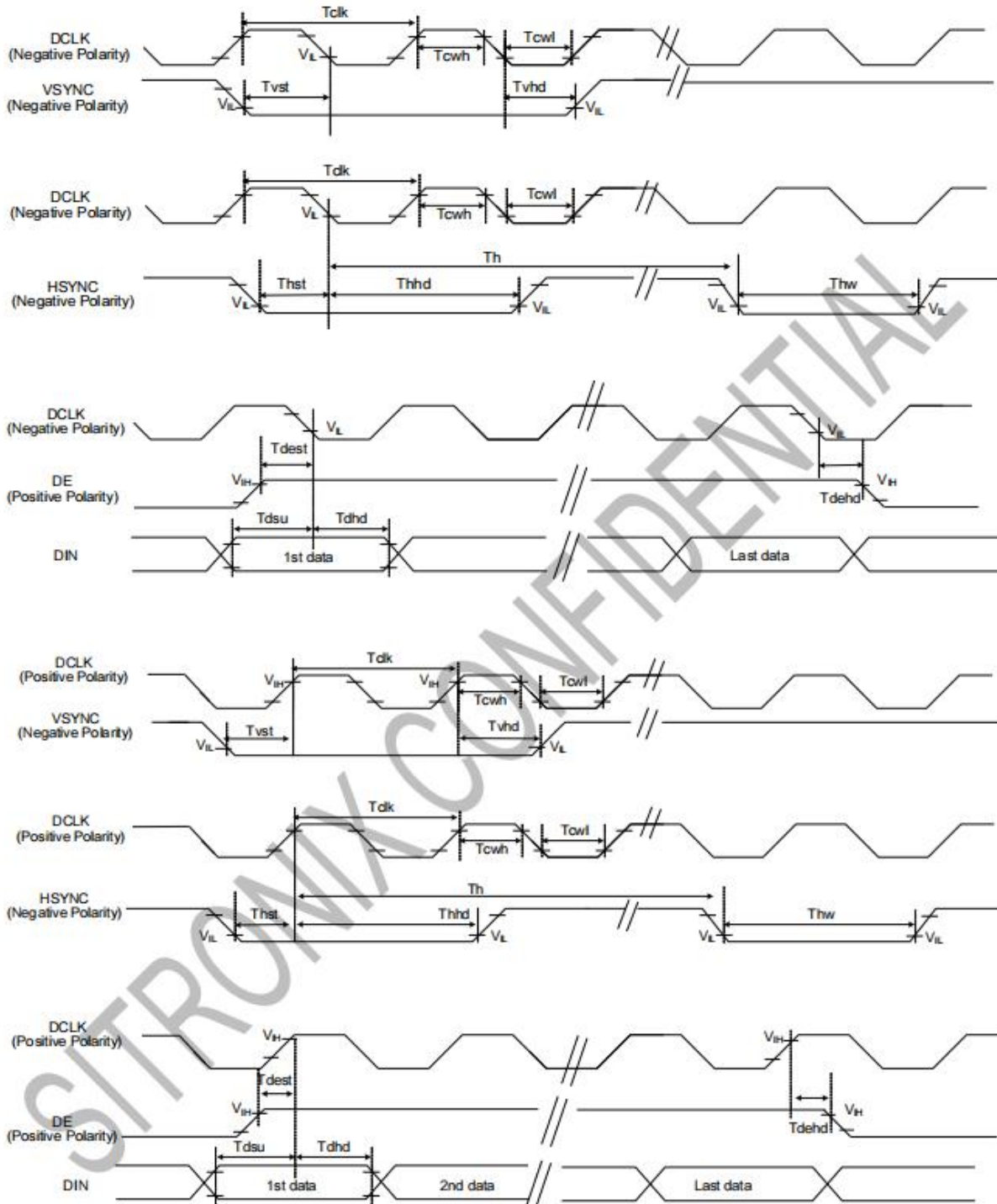



Item	Symbol	Min.	Typ.	Max.	Unit	Conditions
CLK Pulse Duty	Tcw	40	50	60	%	
HSYNC Width	Thw	2	-	-	DCLK	
HSYNC Period	Th	55	60	65	us	
VSYNC Setup Time	Tvst	12	-	-	ns	
VSYNC Hold Time	Tvhd	12	-	-	ns	
HSYNC Setup Time	Thst	12	-	-	ns	
HSYNC Hold Time	Thhd	12	-	-	ns	
Data Setup Time	Tdsu	12	-	-	ns	
Data Hold Time	Tdhd	12	-	-	ns	
DE Setup Time	Tdest	12	-	-	ns	
DE Hold Time	Tdehd	12	-	-	ns	

Parallel 24-bit RGB Input Timing (PVDD=PVDD1=VDD=VDDI= 3.3V, AGND= 0V, TA=25°C)

Parallel 24-bit RGB Interface Timing Table						
Item	Symbol	Min.	Typ.	Max.	Unit	Remark
DCLK Frequency	Fclk	23	25	27	MHz	
HSYNC	Period Time	Th	808	816	896	DCLK
	Display Period	Thdisp	800			DCLK
	Back Porch	Thbp	4	8	48	DCLK
	Front Porch	Thfp	4	8	48	DCLK
	Pulse Width	Thw	2	4	8	DCLK
VSYNC	Period Time	Tv	488	496	504	HSYNC
	Display Period	Tvdisp	480			HSYNC
	Back Porch	Tvbp	4	8	12	HSYNC
	Front Porch	Tvfp	4	8	12	HSYNC
	Pulse Width	Tvw	2	4	8	HSYNC

8. Power Supply Configuration

8.1 Power On

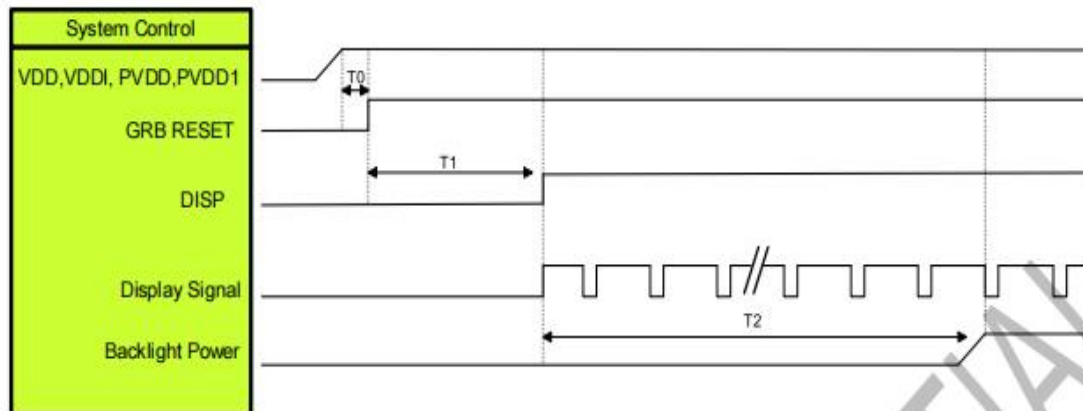

Symbol	Description	Min. Time	Unit
T0	System power stability to GRB RESET signal	0	ms
T1	GRB RESET= "High" to DISP="High"	10	ms
T2	Display Signal output to Backlight Power on	250	ms

Note: RGB interface Display signal: DCLK; VSYNC; HSYNC; DE; DR[7:0]; DG[7:0]; DB[7:0]

Note: LVDS interface Display signal: DCLK P/N; RX[3:0]P/N

8.2 Power Off

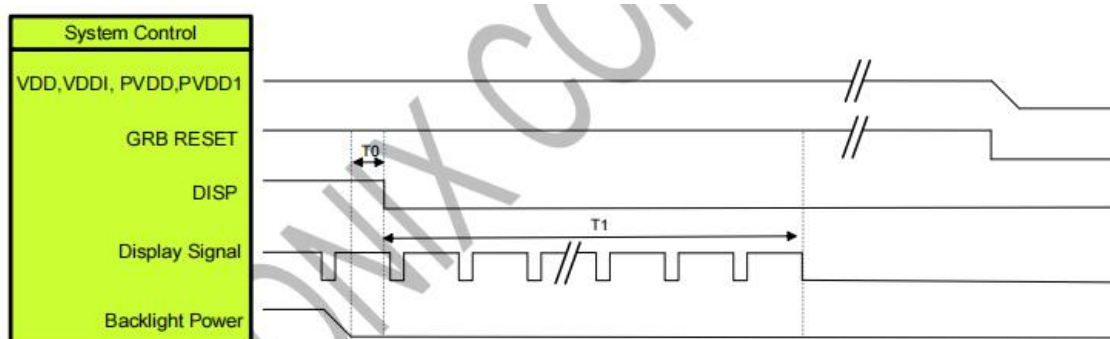

Symbol	Description	Min. Time	Unit
T0	Backlight Power off to DISP="Low"	5	ms
T1	DISP="Low" to IC internal voltage discharge complete	100	ms

Note: RGB interface Display signal: DCLK; VSYNC; HSYNC; DE; DR[7:0]; DG[7:0]; DB[7:0]

Note: LVDS interface Display signal: DCLK P/N; RX[3:0]P/N

 福瑞达 深圳市福瑞达显示技术有限公司 SHENZHEN FRIDA LCD CO.,LTD	Doc.No.: FRD500H40119-A-CT2K	
	REV: A	PAGE: 13/20
SPEC TITLE DOCUMENT CONTROL SPECIFICATION	EFFECTIVE DATE: 2025-12-03	

9.Optical Specification

Item 项目	Symbol 符号	Condition 条件	Min 最小值	Typ 典型值	Max 最大值	Unit 单位	Note 备注
Response time 响应时间	Tr+Tf	$\Theta=0^{\circ}$ $\varnothing=0^{\circ}$ $T_a=25^{\circ}\text{C}$	-	30	40	ms	1
Contrast ratio 对比度	Cr		800	1000	-	-	2
Color gamut 饱和度	S(%)		45	50	-	%	-
Luminance uniformity 均匀度	δ WHITE		80	-	-	%	3
Viewing angle range 视角范围	Θ_{x+}	$CR \geq 10$ $T_a=25^{\circ}\text{C}$	-	80	-	deg	4
	Θ_{x-}		-	80	-	deg	
	Θ_{y+}		-	80	-	deg	
	Θ_{y-}		-	80	-	deg	
LCM Luminance LCM 亮度	Lv	$\Theta=0^{\circ}$ $\varnothing=0^{\circ}$ $T_a=25^{\circ}\text{C}$	-	400	-	Cd/m ²	5

Note1.Response time is the time required for the display to transition from White to black(Rise Time,Tr)and from black to white(Decay Time,Tf).For additional information see FIG1...

Note2.contrast Ratio(CR) is defined mathematically by the following formula ,For more information see FIG2.

Contrast Ratio(CR)=Average Surface Luminance with all white pixels/ Average Surface Luminance with all black pixels

Note3.The uniformity in surface luminance(WHITE) is determined by measuring luminance at each test position,and then dividing the maximum luminance of all white pixels by minimum luminance of all white pixels,For more information seeFIG2.

WHITE=Minimum Surface Luminance with all white pixels(P1,P2,.....)/Maximum Surface Luminance with all white pixels(P1,P2,.....)

Note4.Viewing angle is the angel at which contrast ratio is greater than a specific value.For TET module,the specific value of contrast ratio is 10.For monochrome and color stn module,the specific

value of contrast ratio is 2. The angles are determined for the horizontal or x axis and the vertical or y axis with respect to the z axis which is normal to the LCD surface. For more information see FIG3 Note5. Surface luminance is the LCD surface luminance with all white pixels, For more information see FIG2.

LV=Average Surface Luminance with all white pixels(P1,P2,.....)

FIG1. The definition of Response time

响应时间定义

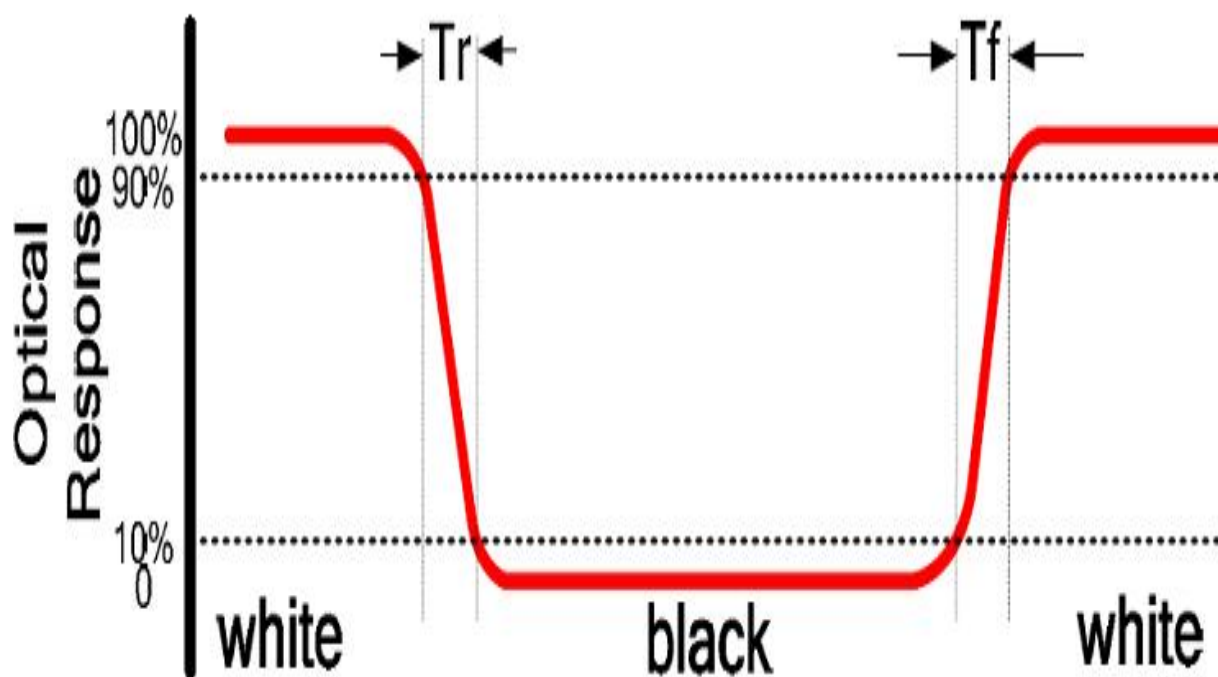

FIG2. Measuring method for Contrast ratio, surface luminance, Luminance

uniformity, CIE(X,Y) chromaticity.

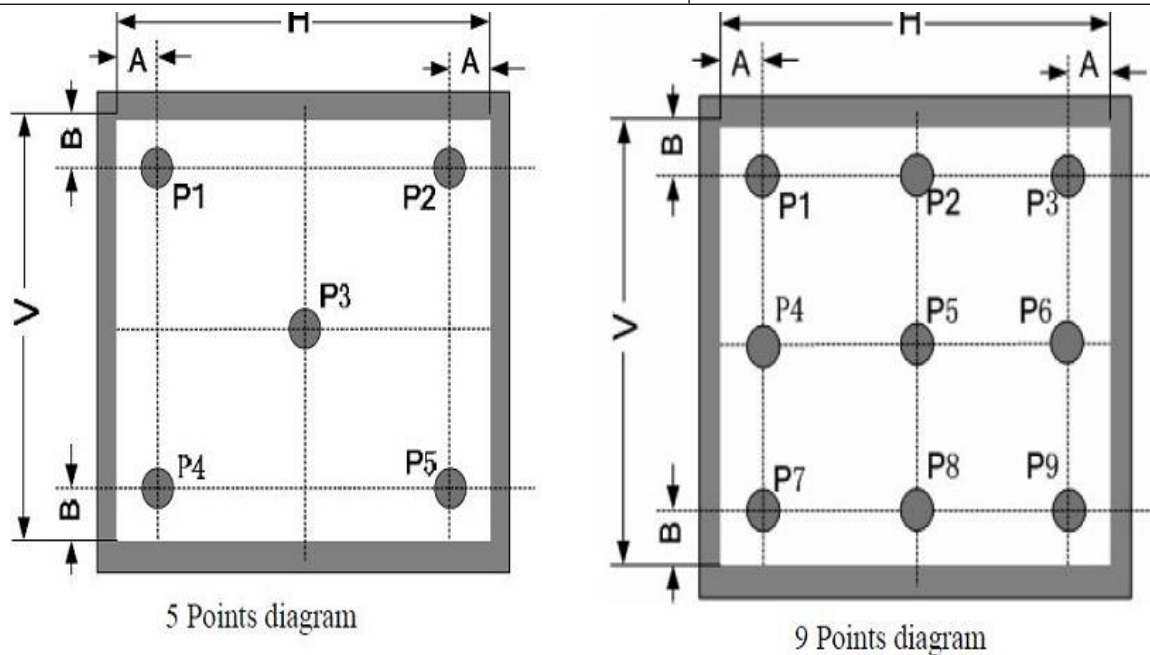
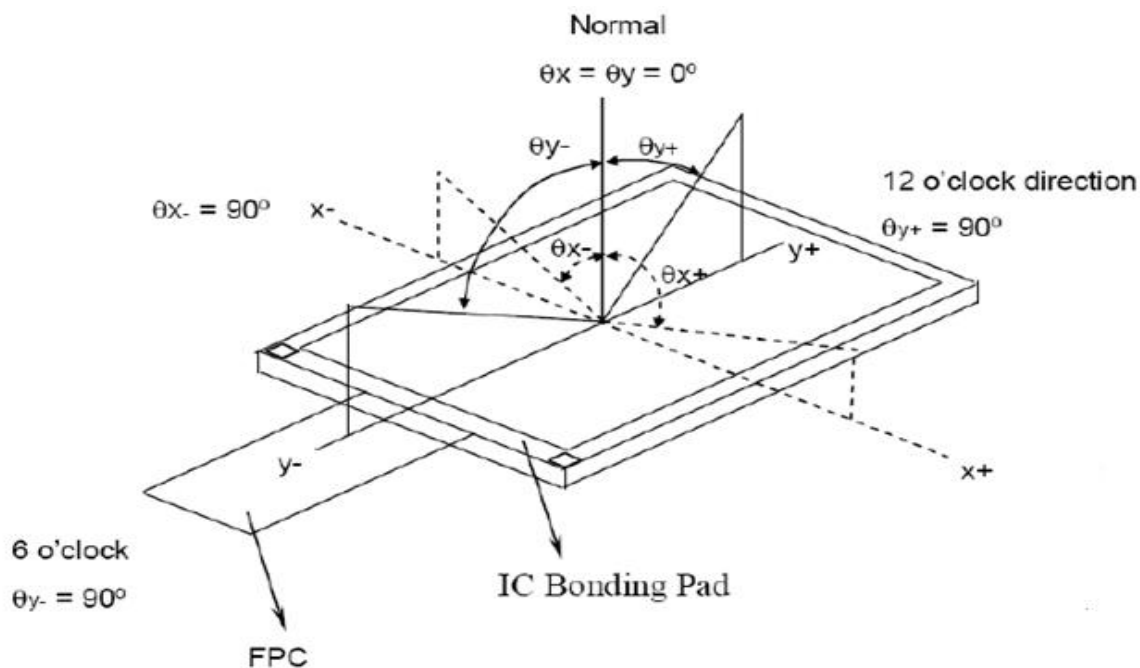

FIG3 The definition of viewing angle 视角定义



10. Inspection Specifications

10.1 Appearance inspection

Item	Acceptable standards for defects	Defect level
Broken	Not allowed	critical defects
Cracks	Not allowed	critical defects
Insufficient UV glue entering	Not allowed	critical defects
Liquid crystal seal leakage	Not allowed	critical defects
Liquid crystal bubbles	Not allowed	critical defects
Surface scratch(mm)	$W \leq 0.02$, ignored	minor defects
	$0.02 < W \leq 0.03$ $L \leq 2, N \leq 2$	
	$0.03 < W \leq 0.05$ $L \leq 1, N \leq 1$	
	$0.05 < W$ Not allowed	
Black/white spot(mm)	$D \leq 0.1$, ignored; $0.1 < D \leq 0.15, N \leq 4$	minor defects
	$0.15 < D \leq 0.2, N \leq 2$; $0.2 < D$, Not allowed	
The seal pollution	Not allowed	minor defects
Liquid crystal residues	Not allowed	minor defects
Surface stains	Stains that cannot be cleaned or erased are not allowed	minor defects
size	Refer to the product specification corresponding to each product, overall size(including length, Width, thickness) or partial size exceeding the drawing size is not allowed	major defects

Remarks : 1) Surface scratches within 1.5mm of the glass edge are ignored;

2) D = diameter, L = length, W = width, N = qty;

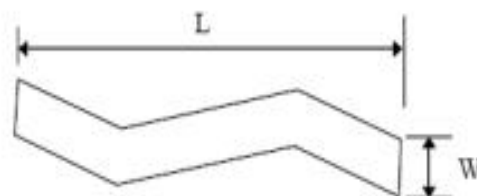
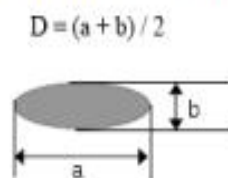

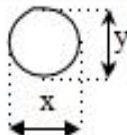
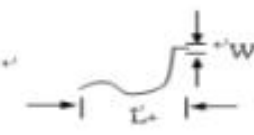

10.2 Functional test criteria

Item	Judgment	Level																				
Display status	No Display、Incomplete image、line defect、wrong viewing angle、flickering、abnormal image、are not allowed	major defects																				
	Display color, judged by approved samples, Or by limited samples	minor defects																				
	MURA or the phenomenon that is unable to describe in words, judged by ND 5% or limited samples	minor defects																				
Spot(bright/dark)defect	Definition of spot defect: $\Phi = (x+y) / 2$ 	minor defects																				
	<table border="1"> <thead> <tr> <th rowspan="2">Size(mm)</th> <th colspan="2">acceptable qty</th> </tr> <tr> <th>Active area</th> <th>View area</th> </tr> </thead> <tbody> <tr> <td>$\Phi \leq 0.1$</td> <td colspan="2">ignored</td> </tr> <tr> <td>$0.1 < \Phi \leq 0.15$</td> <td colspan="2">2 (gap ≥ 5)</td> </tr> <tr> <td>$0.15 < \Phi \leq 0.2$</td> <td colspan="2">1</td> </tr> <tr> <td>$0.2 < \Phi$</td> <td colspan="2">Not allowed</td> </tr> </tbody> </table>		Size(mm)	acceptable qty		Active area	View area	$\Phi \leq 0.1$	ignored		$0.1 < \Phi \leq 0.15$	2 (gap ≥ 5)		$0.15 < \Phi \leq 0.2$	1		$0.2 < \Phi$	Not allowed				
	Size(mm)			acceptable qty																		
			Active area	View area																		
	$\Phi \leq 0.1$		ignored																			
	$0.1 < \Phi \leq 0.15$		2 (gap ≥ 5)																			
$0.15 < \Phi \leq 0.2$	1																					
$0.2 < \Phi$	Not allowed																					
Black/white line	Definition of line defect: L: length, W: width 	minor defects																				
	<table border="1"> <thead> <tr> <th colspan="2">Size(mm)</th> <th colspan="2">Acceptable qty</th> </tr> <tr> <th>W(width)</th> <th>L(length)</th> <th>Active area</th> <th>View area</th> </tr> </thead> <tbody> <tr> <td>$W \leq 0.03$</td> <td>ignored</td> <td>ignored</td> <td>ignored</td> </tr> <tr> <td>$0.03 < W \leq 0.05$</td> <td>$L \leq 2.0$</td> <td>3</td> <td></td> </tr> <tr> <td>$W > 0.05$</td> <td>-</td> <td>Not allowed</td> <td></td> </tr> </tbody> </table>		Size(mm)		Acceptable qty		W(width)	L(length)	Active area	View area	$W \leq 0.03$	ignored	ignored	ignored	$0.03 < W \leq 0.05$	$L \leq 2.0$	3		$W > 0.05$	-	Not allowed	
	Size(mm)		Acceptable qty																			
	W(width)		L(length)	Active area	View area																	
	$W \leq 0.03$		ignored	ignored	ignored																	
$0.03 < W \leq 0.05$	$L \leq 2.0$	3																				
$W > 0.05$	-	Not allowed																				

 福瑞达 深圳市福瑞达显示技术有限公司 SHENZHEN FRIDA LCD CO.,LTD	Doc.No.: FRD500H40119-A-CT2K	
	REV: A	PAGE: 18/20
SPEC TITLE DOCUMENT CONTROL SPECIFICATION	EFFECTIVE DATE: 2025-12-03	

11. Reliability Test Items

Item	Test Condition	Criterion
High Temperature Storage	80 °C, 48 hrs	Note1,Note2
Low Temperature Storage	-30 °C, 48 hrs	
High Temp. & High Humidity Storage	40 °C, 80% RH, 48hrs	
Thermal Shock (Static)	-20°C, 30 min /70°C, 30 min, 20 cycles	
High Temperature Operation	70 °C, 48 hrs	
Low temperature Operation	-20 °C, 48 hrs	

Note1: Evaluation should be tested after storage at room temperature for two hours.

Note2:

Pass: Normal display image no line defect.

Fail: No display image, or line defects.

Partial transformation of the module parts should be ignored.

12. Precautions

Please pay attentions to the followings as using the LCD module.

Handling

- (a) Do not apply strong mechanical stress like drop, shock or any force to LCD module. It may cause improper operation, even damage.
- (b) Because the polarizer is very fragile and easy to be damaged, do not hit, press or rub the display surface with hard materials.
- (c) Do not put heavy or hard material on the display surface, and do not stack LCD modules.
- (d) If the display surface is dirty, please wipe the surface softly with cotton swab or clean cloth.

 福瑞达 深圳市福瑞达显示技术有限公司 SHENZHEN FRIDA LCD CO.,LTD	Doc.No.: FRD500H40119-A-CT2K	
	REV: A	PAGE: 19/20
SPEC TITLE DOCUMENT CONTROL SPECIFICATION	EFFECTIVE DATE: 2025-12-03	

- (e) Avoid using Ketone type materials (e.g. Acetone), Toluene, Ethyl acid or Methyl chloride to clean the display surface. It might damage the touch panel surface permanently. The recommended solvents are water and Isopropyl alcohol.
- (f) Wipe off water droplets or oil immediately.
- (g) Protect the LCD module from ESD. It will damage the LSI and the electronic circuit.
- (h) Do not touch the output pins directly with bare hands.
- (i) Do not disassemble the LCD module.
- (j) Do not lift the FPC of Touch Panel.

Storage

- (a) Do not leave the LCD modules in high temperature, especially in high humidity for a long time.
- (b) Do not expose the LCD modules to sunlight directly.
- (c) The liquid crystal is deteriorated by ultraviolet. Do not leave it in strong ultraviolet ray for a long time.
- (d) Avoid condensation of water. It may cause improper operation.
- (e) Please stack only up to the number stated on carton box for storage and transportation. Excessive weight will cause deformation and damage of carton box.

Operation

- (a) When mounting or dismounting the LCD modules, turn the power off.
- (b) Protect the LCD modules from electric shock.
- (c) The Driver IC control algorithms stated above should always obeyed to avoid damaging the LSI and electronic circuit.
- (d) Be careful to avoid mixing up the polarity of power supply for backlight.
- (e) Absolute maximum rating specified above has to be always kept in any case. Exceeding it may cause non-recoverable damage of electronic components or, nevertheless, burning.
- (f) When a static image is displayed for a long time, remnant image is likely to occur.
- (g) Be sure to avoid bending the FPC to an acute shape, it might break FPC.
- (h) Most of the touch screens have air vent to equalize the inside air pressure to the outside one. The air vent must be open and liquid contact must be avoided as the liquid may be absorbed if the

 福瑞达 深圳市福瑞达显示技术有限公司 SHENZHEN FRIDA LCD CO.,LTD	Doc.No.: FRD500H40119-A-CT2K	
	REV: A	PAGE: 20/20
SPEC TITLE DOCUMENT CONTROL SPECIFICATION	EFFECTIVE DATE: 2025-12-03	

liquid is accumulated near the air vent.

- (i) For the fragility of ITO film, it should avoid to use too tapering pen as the input material.

Touch Panel Mounting Notes

- (a) If a cushion is used between bezel/housing and film must be choose as free as enough to absorb the expansion and contraction to avoid the distortion of film.
- (b) The cushion must be placed out of the Viewing Area.
- (c) Bezel/Housing edge must be posited between Key Area and Viewing Area. The edge enters the Key Area may cause unexpected input if the gap is too narrow or foreign particles like dusts exist between Bezel/Housing and ITO film.

- (d) Mounting example:

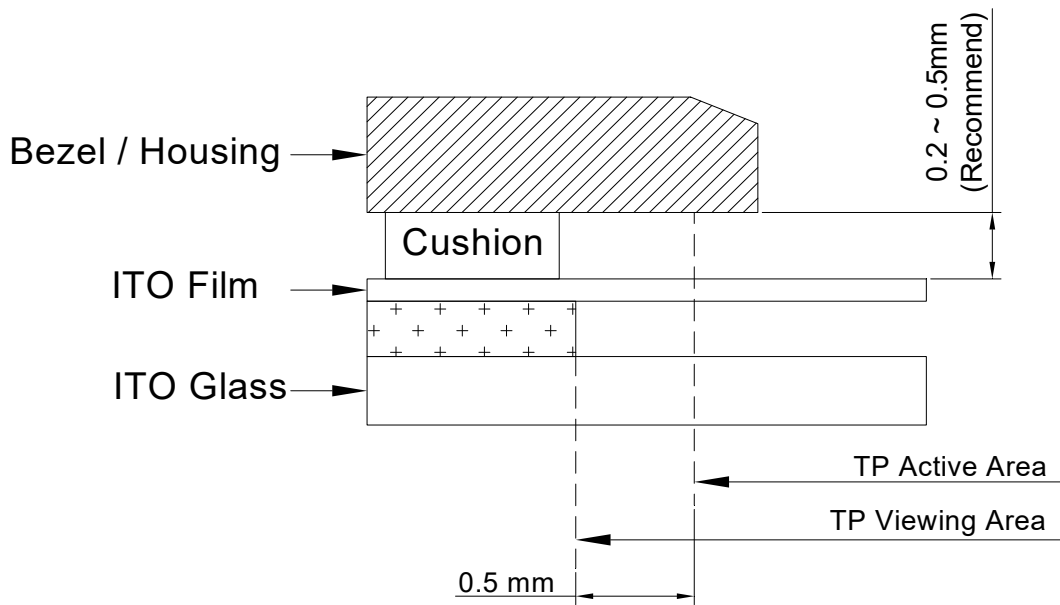

The corner part has conductivity. Do not touch any metal part after mounting.

Others

- a) If the liquid crystal leaks from the panel, it should be kept away from the eyes or mouth.
- b) For the fragility of polarizer, it is recommended to attach a transparent protective plate over the display surface.
- c) It is recommended to peel off the protection film on the polarizer slowly so that the electrostatic charge can be minimized.