

FEATURES

1. Package Type: 1"X 1"
2. Operating temperature range: -40°C - +105°C
3. Isolation voltage: 1500VDC
4. High efficiency up to 91%
5. The mechanism has input undervoltage protection,
6. output short circuit protection and over current protection
7. 2:1 Ultra-wide input voltage range
8. Fields of application: Power, industrial control, communications, Internet of Things, automotive, etc



3 years
Warranty

Selection Guide

Part No.	Input Voltage (VDC)		Output		Full Load Efficiency% (Typ.)	Capacitive Load(μF) Max.
	Nominal (Range)	Maximum	Voltage (VDC)	Current (mA)		
MFB1203YMD-15WR3	12 (9-18)	20	3.3	4000/0	86/88	4700
MFB1205YMD-15WR3			5	3000/0	88/90	4700
MFB1212YMD-15WR3			12	1250/0	88/90	1000
MFB1215YMD-15WR3			15	1000/0	89/91	820
MFB1248YMD-15WR3			48	313/0	88/89	100
MFB2403YMD-15WR3	24 (18-36)	40	3.3	4000/0	86/88	4700
MFB2405YMD-15WR3			5	3000/0	88/89	4700
MFB2412YMD-15WR3			12	1250/0	88/89	1000
MFB2415YMD-15WR3			15	1000/0	89/91	820
MFA2405YMD-15WR3			±5	±1500/0	88/89	#1500
MFA2412YMD-15WR3			±12	±625/0	88/89	#470
MFA2415YMD-15WR3	±15	±500/0	89/91	#330		
MFB4803YMD-15WR3	48 (36-75)	80	3.3	4000/0	86/88	4700
MFB4805YMD-15WR3			5	3000/0	88/90	4700
MFB4812YMD-15WR3			12	1250/0	89/91	1000
MFB4815YMD-15WR3			15	1000/0	89/91	820
MFB4824YMD-15WR3			24	625/0	89/91	820

each output

Input Specifications

Item	Operating Conditions	Min.	Typ.	Max.	Unit	
Input Current(full load/no-load)	12VDC nominal input series	3.3V	--	1250/40	1280/65	mA
		5V	--	1389/40	1421/65	
		12V	--	1389/7	1421/22	
		15V	--	1374/7	1405/22	
		24V	--	1374/12	1405/22	
	24VDC nominal input series	3.3V	--	625/30	647/50	
		5V	--	695/30	711/50	
		12V	--	695/6	711/15	
		15V	--	687/6	703/15	
		24V	--	687/10	703/20	
	48VDC nominal input series	3.3V	--	313/15	320/30	
		5V	--	348/15	356/30	
		12V	--	344/3	352/11	
		15V	--	344/3	352/11	
		24V	--	344/4	352/11	
Reflected Ripple Current	nominal input series	--	60	--		
Impulse Voltage	12VDCnominal input series	-0.7	--	25	VDC	
	24VDCnominal input series	-0.7	--	50		
	48VDCnominal input series	-0.7	--	100		
Starting Voltage	12VDCnominal input series	--	--	9		
	24VDCnominal input series	--	--	--		
	48VDCnominal input series	--	--	18		
Input undervoltage protection	12VDCnominal input series	5.5	6.5	--		
	24VDCnominal input series	12	15.5	--		
	48VDCnominal input series	26	30	--		
Ctrl	turn off module	connected GND or (0-1.2V)				
	turn on module	No connected or (3.5-12V)				
	Input current when off	--	5	8	mA	
Input Filter	PI filter					

Output Specifications

Item	Operating Conditions	Min.	Typ.	Max.	Unit
Output Voltage Accuracy	0%-100% load	--	±1.0	±3.0	%
Linear Regulation	Vin=Min. to Max. @Full Load	--	±0.2	±0.5	
Load Regulation	5%-100% load	--	±0.5	±1.0	

Ripple & Noise	20MHz bandwidth,5%-100% load	--	50	100	mVp-p
Transient Recovery Time	25% Load Step Change,nominal input voltage	--	300	500	μs
Transient Response Deviation		--	±3	±8	%
Temperature Coefficient	Full Load	--	--	±0.03	%/°C
Trim	input voltage range	--	±10.0	--	%
Over Voltage Protection		110	--	160	%
Over Current Protection		110	150	190	%
Short-Circuit Protection		Continuous, Self-Recovery			

General Specifications

Item	Operating Conditions	Min.	Typ.	Max.	Unit
Isolation Voltage	Input-output, test time 1 minute, leakage current less than 1mA	1500	--	--	VDC
Insulation Resistance	Input-output, insulated voltage 500VDC	1000	--	--	MΩ
Isolation Capacitance	Input-output, 100KHz/0.1V	--	2000	--	pF
Operating Temperature	See Fig 1	-40	--	+105	°C
Storage Temperature		-50	--	+125	
Storage Humidity	Non-condensing	--	--	95	%RH
Soldering Profile	1.5mm from case for 10 sec	--	--	300	°C
Switching Frequency	Full load, nominal input voltage	--	300	--	kHz
MTBF	MIL-HDBK-217F@25°C	1000	--	--	K Hours

Mechanical Specifications

Case Material	Aluminum alloy
Package Dimensions	25.4mm * 25.40mm * 12.00 mm
Weight	16.0g(Typ.)
Cooling Method	Free air convection

EMC Specifications

EMI	CE	EN55032, FCC part 15	CLASS B
	RE		
EMS	ESD	EN61000-4-2 Air ± 8kV , Contact ± 6kV	perf. Criteria B
	RS	EN61000-4-3 10V/m	perf. Criteria A
	EFT	EN61000-4-4 ±2kV	perf. Criteria B
	Surge	EN61000-4-5 ±1kV	perf. Criteria B
	CS	EN61000-4-6 3Vrms	perf. Criteria A

Typical Characteristic Curves

Nominal input voltage, 12V, 15V, 24V output

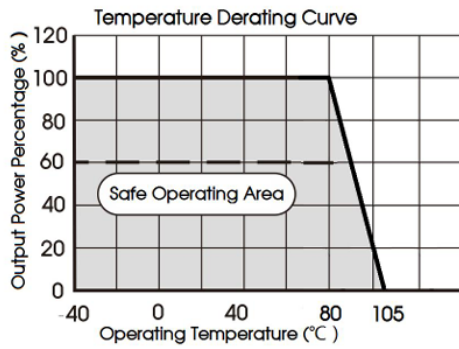

Nominal input voltage, 3.3V, 5V output

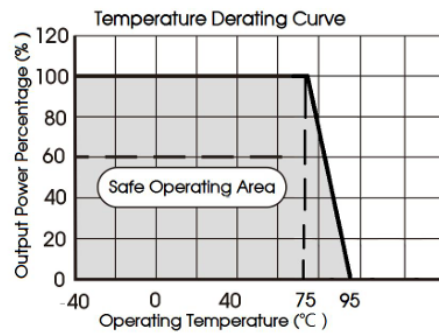
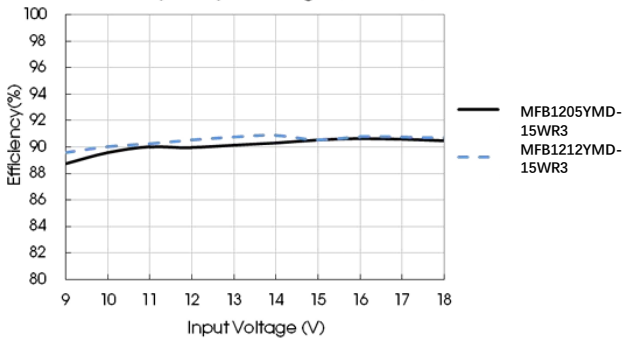
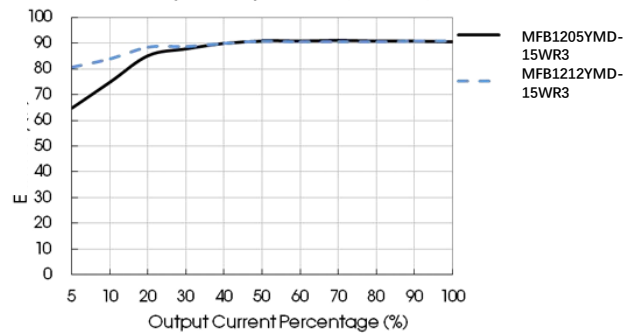

Fig. 1

Efficiency Vs Input Voltage (Full Load)



Efficiency Vs Output Load (Vin=12V)



Efficiency Vs Input Voltage (Full Load)

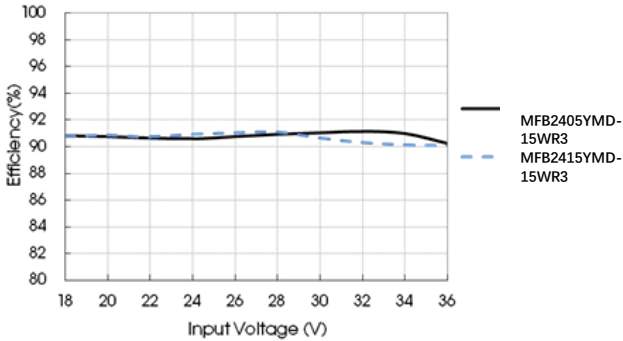

Efficiency Vs Output Load (Vin=24V)

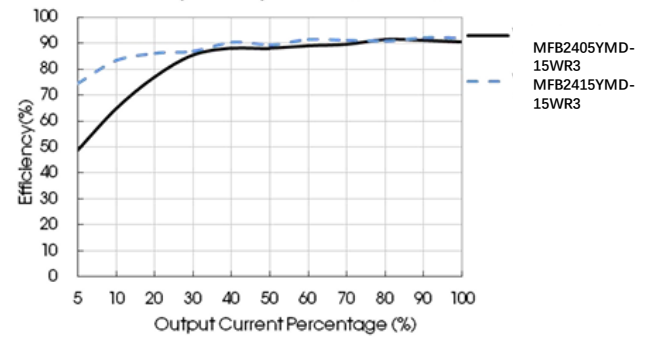

Efficiency Vs Input Voltage (Full Load)

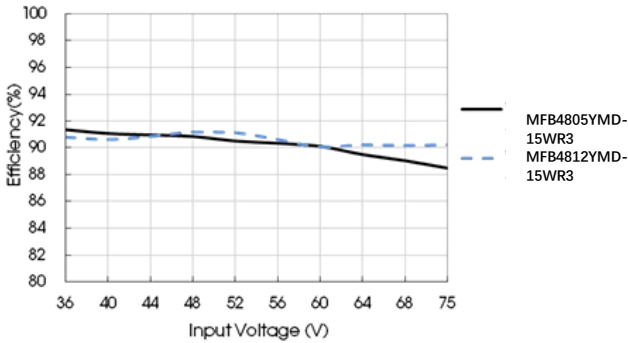

Efficiency Vs Output Load (Vin=48V)

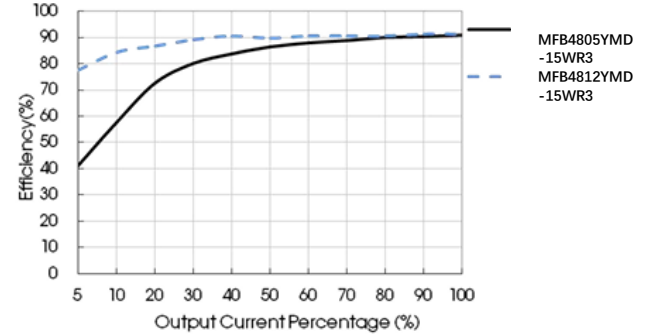

Typical Circuit Design And Application

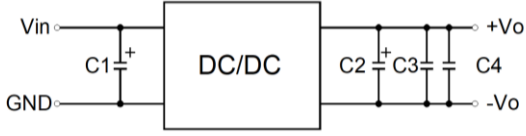

Recommended component parameters				
Vin(VDC)	C1(uF)	C2(uF)	C3(uF)	C4(uF)
24	100	470	10	0.1
48			22	10

Fig 2

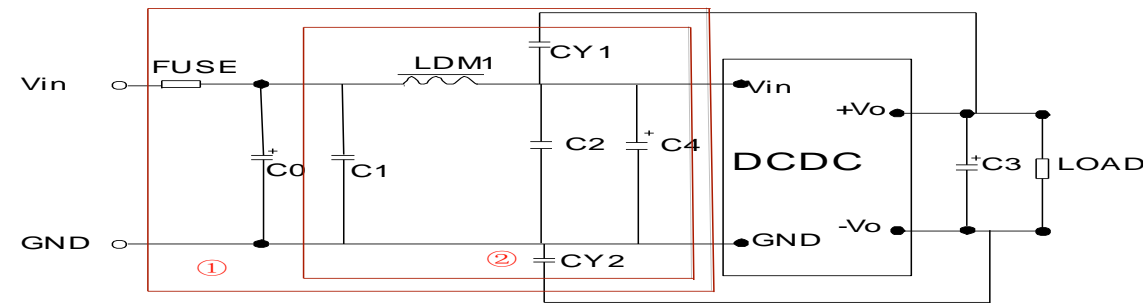
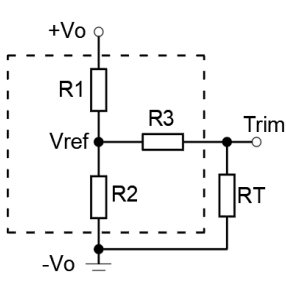
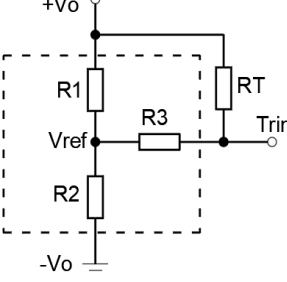

Fig 3

EMI recommended component parameters						
Vin (VDC)	FUSE	C0、C4	C1、C2	C3	LCM1	CY1/CY2
24V	Choose according to actual input	330μF/50V		Refer to the Cout parameter in Figure 2	2.2uH/4A	1nF/2KV
48V		330μF/100V				



Trim up



Trim down

Trim resistor connections (dashed line shows internal resistor network)

Trim				
Vout(V)	R1(KΩ)	R2(KΩ)	R3(KΩ)	Vref(V)
3.3	10	6.064	13.622	1.24
5	2.4	2.344	13.622	2.5
12	8.2	2.153	17.346	2.5
15	12	2.388	21.016	2.5
24	10	1.158	10.714	2.5

Up: $R_t = \frac{nR_2}{R_2 - n} - R_3$ $n = \frac{V_{ref}}{V_o - V_{ref}} * R_1$

Down: $R_t = \frac{nR_1}{R_1 - n} - R_3$ $n = \frac{V_o - V_{ref}}{V_{ref}} * R_2$

All DC-DC converters of this series are tested before delivery using the recommended circuit shown in Fig. 2. Input and/or output ripple can be further reduced by appropriately increasing the input & output capacitor values C_{in} and C_{out} and/or by selecting capacitors with a low ESR (equivalent series resistance). Also make sure that the capacitance is not exceeding the specified max. capacitive load value of the product.

Dimensions and Recommended Layout

Dimensions

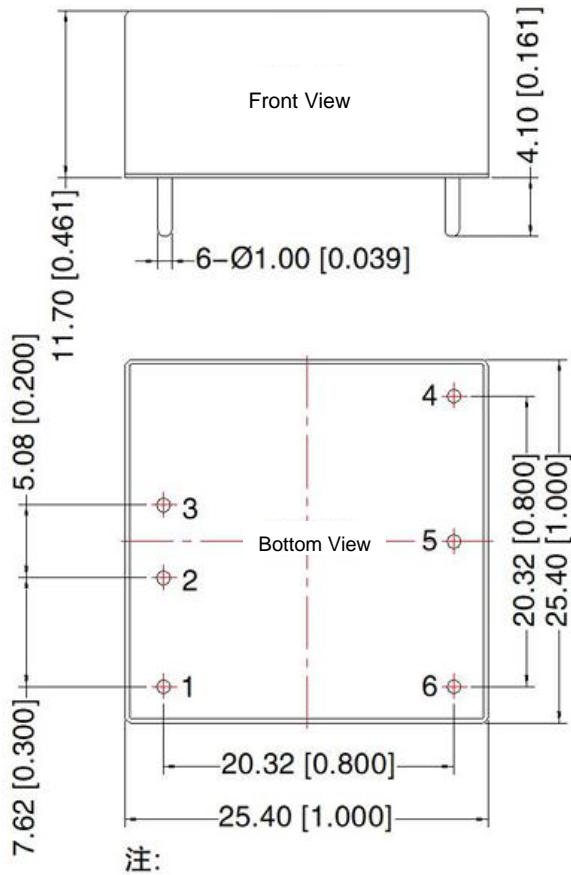

PCB Printing Layout & Pin Definition Table

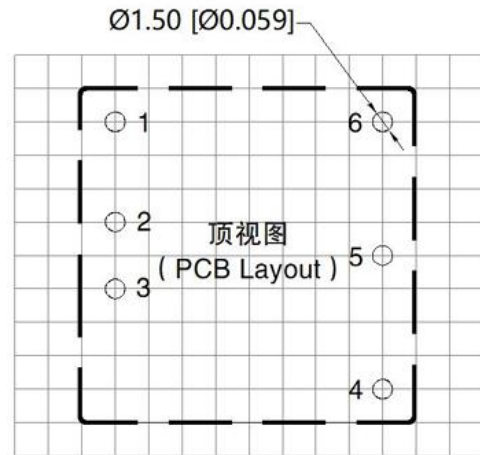

Pin	Function(S)	Function(D)
1	Ctrl	Ctrl
2	GND	GND
3	Vin	Vin
4	+Vo	+V0
5	Trim	Trim
6	0V	-Vo

Note:

Unit: mm[inch]

Pin section tolerances: $\pm 0.10 [\pm 0.004]$

General tolerances: $\pm 0.50 [\pm 0.020]$

Note: The grid distance is 2.54*2.54mm

Notes & Instructions

1. If the product works under the minimum required load, it cannot guarantee that the performance of the product complies with all the performance indicators in this manual;
2. The maximum capacitive load is tested under the input voltage range and full load condition;
3. Unless otherwise stated, all indexes in this manual are measured at $T_a=25^\circ\text{C}$, humidity $<75\%\text{RH}$, nominal input voltage and rated output load;
4. All index testing methods in this manual are based on the enterprise standards of the company;
5. Our company can provide product customization, specific needs can directly contact our technical staff;

NORPAS-POWER TECHNOLOGY CO., LTD.

www.norpas-power.com Mail: info@norpas-power.com

Specifications can be changed without notice! Make sure you are using the latest documentation, downloadable at www.norpas-power.com

REV:07/2024