

FEATURES

1. Ultra compact SIP package
2. Wide 2:1 input voltage range
3. Operating ambient temperature range: -40°C to +85°C
4. I/O isolation test voltage 3k VDC
5. High power density
6. Short circuit protection (self-recovery)
7. Remote On/Off



3 years
Warranty

Selection Guide

Part No.	Input Voltage (VDC)		Output		Full Load Efficiency (%) Min./Typ.	Capacitive Load (µF)Max.
	Nominal (Range)	Max.	Voltage(VDC)	Current (mA) Max./Min.		
NKE0505S-1WR2	5 (4.5-9)	11	±5	±100/±5	71/73	1000
NKE0512S-1WR2			±12	±42/±2	74/76	470
NKE0515S-1WR2			±15	±33/±2	73/75	330
NKF0503S-1WR2			3.3	303/15	69/71	1800
NKF0505S-1WR2			5	200/10	70/72	2200
NKF0512S-1WR2			12	83/4	74/76	1000
NKF0515S-1WR2			15	67/3	73/75	680
NKE1205S-1WR2	12 (9-18)	20	±5	±100/±5	75/77	1000
NKE1212S-1WR2			±12	±42/±2	79/81	470
NKE1215S-1WR2			±15	±33/±2	76/78	330
NKF1203S-1WR2			3.3	303/15	73/75	2700
NKF1205S-1WR2			5	200/10	75/77	2200
NKF1209S-1WR2			9	111/6	77/79	1800
NKF1212S-1WR2			12	83/4	76/78	1000
NKF1215S-1WR2	15	67/3	78/80	680		
NKE2405S-1WR2	24 (18-36)	40	±5	±100/±5	77/79	1000
NKE2412S-1WR2			±12	±42/±2	76/78	470
NKE2415S-1WR2			±15	±33/±2	76/78	330
NKF2403S-1WR2			3.3	303/15	73/75	2700
NKF2405S-1WR2			5	200/10	75/77	2200
NKF2412S-1WR2			12	83/4	76/78	1000
NKF2415S-1WR2			15	67/3	76/78	680
NKF2424S-1WR2	24	42/2	75/77	470		
NKE4805S-1WR2	48 (36-75)	80	±5	±100/±5	74/76	1000
NKE4812S-1WR2			±12	±42/±2	76/78	470
NKE4815S-1WR2			±15	±33/±2	78/80	330
NKF4803S-1WR2			3.3	303/15	73/75	2700
NKF4805S-1WR2			5	200/10	74/76	2200
NKF4812S-1WR2			12	83/4	78/80	1000
NKF4815S-1WR2			15	67/3	77/79	680

Input Specifications

Item	Operating Conditions		Min.	Typ.	Max.	Unit
Input Current (full load/no-load)	5VDC Input	others	--	278/40	286/60	mA
		NKF0503S-1WR2	--	281/25	289/30	
	12VDC Input		--	107/15	110/30	
	24VDC Input		--	54/6	55/10	
48VDC Input		--	27/4	28/6		
Reflected Ripple Current	5VDC Input		--	30	--	
	12VDC Input		--	40	--	
	24VDC Input		--	55	--	
	48VDC Input		--	45	--	
Surge Voltage (1sec. max.)	5VDC Input		-0.7	--	12	VDC
	12VDC Input		-0.7	--	25	
	24VDC Input		-0.7	--	50	
	48VDC Input		-0.7	--	100	
Start-up Voltage	5VDC Input		3.5	4	4.5	
	12VDC Input		4.5	8	9	
	24VDC Input		11	16	18	
	48VDC Input		24	33	36	
Input Filter			Capacitance filter			
Hot Plug			Unavailable			
Ctrl*	Module on		Ctrl pin open (high resistance)			
	Module off		Ctrl pin pulled high (current 5-10mA typ. into Ctrl.)			

Note: *For use of Ctrl, please refer to the "design reference" in this manual.

Output Specifications

Item	Operating Conditions		Min.	Typ.	Max.	Unit
Voltage Accuracy	5%-100% load	3.3V/5V output	--	±3	±5	%
		NKF0503S-1WR2, others	--	±1	±3	
Linear Regulation	Input voltage variation from low to high at full load		--	±0.2	±0.5	
Load Regulation	5%-100% load		--	±0.4	±0.75	
Transient Recovery Time	25% load step change		--	0.5	2	ms
Transient Response Deviation			--	±2.5	±5	%
Temperature Coefficient	Full load		--	±0.02	±0.03	%/°C
Ripple & Noise *	20MHz bandwidth	NKF0503S-1WR2	--	75	100	mVp-p
		NKE/F05_S-1WR2, NKE/F24_S-1WR2	--	70	100	
		NKE/F12_S-1WR2, NKE/F48_S-1WR2	--	100	150	
Short-circuit Protection			Continuous, self-recovery			

Note: *The "parallel cable" method is used for ripple and noise test, please refer to DC-DC Converter Application Notes for specific information.

General Specifications

Item	Operating Conditions	Min.	Typ.	Max.	Unit
Isolation	Input-output Electric Strength Test for 1 minute with a leakage current of 1mA max.	3000	--	--	VDC
Insulation Resistance	Input-output resistance at 500VDC	1000	--	--	MΩ
Isolation Capacitance	Input-output capacitance at 100kHz/0.1V	--	30	50	pF
Operating Temperature	see Fig. 1	-40	--	+85	°C
Storage Temperature		-55	--	+125	
Case Temperature Rise	Ta=25°C, nominal input, full load	--	+25	--	
Pin Soldering Resistance Temperature	Soldering spot is 1.5mm away from case for 10 seconds	--	--	+300	
Storage Humidity	Non-condensing	--	--	95	%RH
Switching Frequency (PFM Mode)	Full load, nominal input voltage	--	200	--	kHz
MTBF	MIL-HDBK-217F@25°C	1000	--	--	k hours

Mechanical Specifications

Case Material	Black plastic; flame-retardant and heat-resistant (UL94-V0)
Dimensions	22.00 x 9.50 x 12.00 mm
Weight	4.9g(Typ.)
Cooling Method	Free air convection

EMC Specifications

Emissions	CE	CISPR32/EN55032	CLASS B (see Fig. 3-② for recommended circuit)	
	RE	CISPR32/EN55032	CLASS B (see Fig. 3-② for recommended circuit)	
Immunity	ESD	IEC/EN61000-4-2	Contact ±4kV	perf. Criteria B
	RS	IEC/EN61000-4-3	10V/m	perf. Criteria A
	EFT	IEC/EN61000-4-4	±2kV (see Fig. 3-① for recommended circuit)	perf. Criteria B
	Surge	IEC/EN61000-4-5	line to line ±2kV (see Fig. 3-① for recommended circuit)	perf. Criteria B
	CS	IEC/EN61000-4-6	3 Vr.m.s	perf. Criteria A
	Voltage dips, short interruptions and voltage variations immunity	IEC/EN61000-4-29	0%, 70%	perf. Criteria B

Typical Characteristic Curves

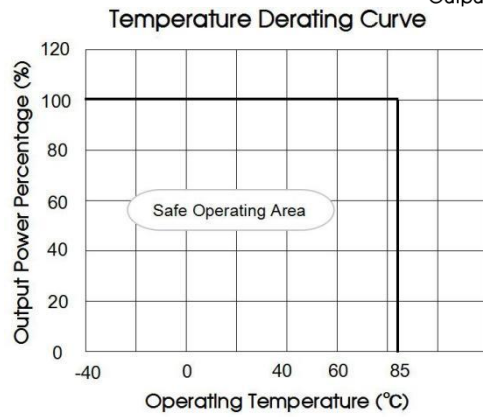
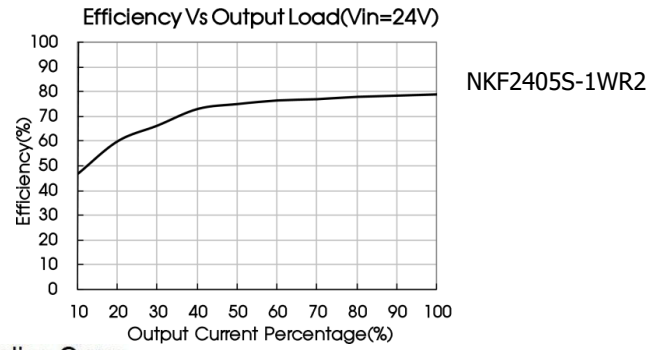
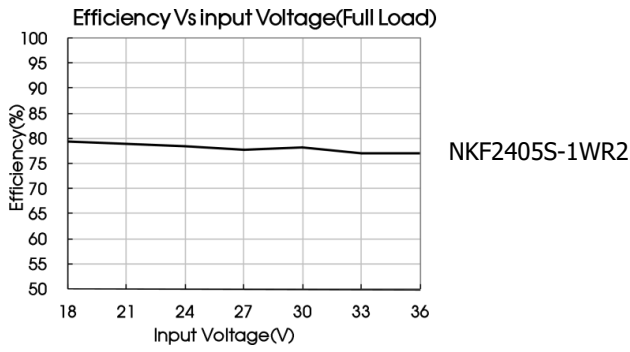
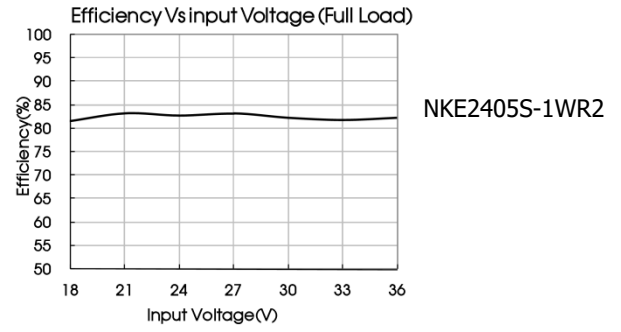
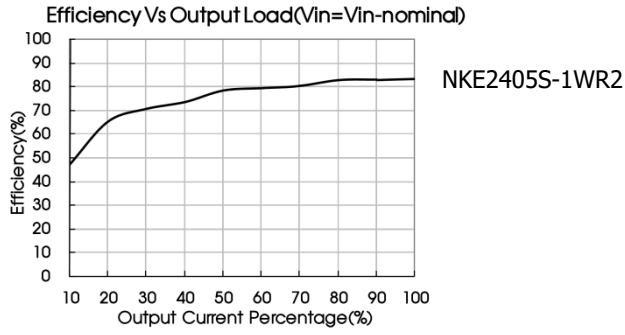

Fig 1

Circuit Design and Application

1. Typical application

All the DC/DC converters of this series are tested before delivery using the recommended circuit shown in Fig. 2. Input and/or output ripple can be further reduced by appropriately increasing the input & output capacitor values C_{in1} , C_{in2} , C_s and C_{out} and/or by selecting capacitors with a low ESR (equivalent series resistance). C_s is used to reduce ripple. No need to add C_s , if ripple meets the demand. Appropriate filter capacitance shall be chosen, start-up problems may be caused if the capacitance is too large. For each output circuit, under the condition of safe and reliable operation, the max. capacity of its filter capacitor should be lower than the max. capacitive load.

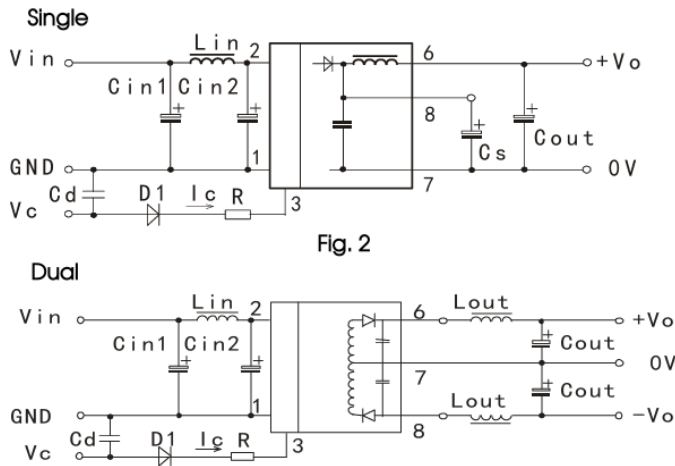
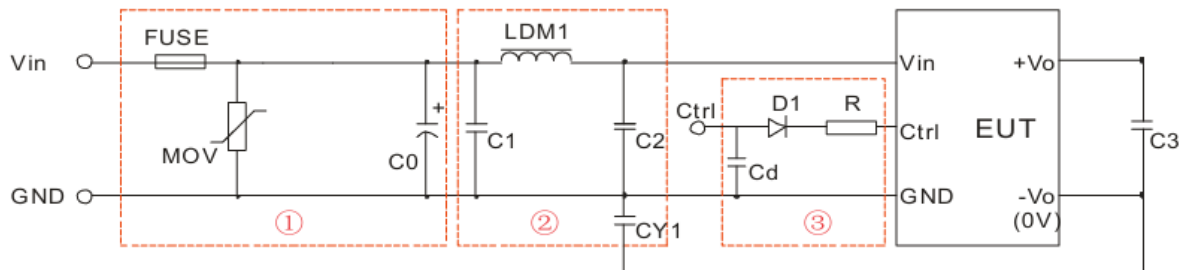

Fig. 2

V_{in}	5VDC&12VDC	24VDC&48VDC
C_{in1}	100 μ F/25VDC	10 μ F/100VDC
C_{in2}	47 μ F/25VDC	1 μ F/100VDC
L_{in}	4.7 μ H-12 μ H	
C_s	10 μ F-22 μ F/50VDC	
C_{out}	100 μ F/50VDC(Typ.)	
C_d	47nF/100V	

2. EMC compliance circuit



Parameter description:

Model	V_{in} : 5VDC	V_{in} : 12VDC	V_{in} : 24VDC	V_{in} : 48VDC
FUSE	Slow-blow, selecting based on needs			
MOV	--	--	S14K35	S14K60
LDM1	--	--	56 μ H	56 μ H
C0	680 μ F/16V	680 μ F/25V	330 μ F/50V	330 μ F/100V
C1	4.7 μ F/50V			4.7 μ F/100V
C2	4.7 μ F/50V			4.7 μ F/100V
C3	Refer to the C_{out} in Fig.2			
CY1	1nF/3kV			
D1	RB160M-60V/1A			
R	In accordance with the formula: $R = \frac{V_C - V_D - 1.0}{I_C} - 300$			
C_d	47nF/100V			

Notes:

- ① For EMC tests we use Part ① in Fig. 3 for immunity and part ② for emissions test. Selecting based on needs.
- ② V_C is the voltage of the Ctrl end relative to the GND of the input grounding; V_D is the positive-going conduction pressure drop of D1; I_C is the current flows into the Ctrl end and its value is generally 5-10mA, see Fig. 3-③ for the peripheral circuit of Ctrl end;
- ③ If there is no recommended parameters, no external component is required.

3. Ctrl end

The modules are of normal output when the Ctrl end is suspended or of high resistance; the modules turn off when connecting with high level (relative to the input grounding); notice that the current flows into the pin shall be 5 - 10mA, the modules will be permanently damaged if the current exceeds its max. value (20mA in general).

The value of R can be derived as follows:

$$R = \frac{V_C - V_D - 1.0}{I_C} - 300$$

For Detailed parameter, please refer to EMC compliance circuit in this manual.

4. Input current

When the electricity is provided by the unstable power supply, please make sure that the range of the output voltage fluctuation and the ripple voltage of the power supply do not exceed the indicators of the modules. Input current of power supply should afford the flash startup current of this kind of DC/DC module(see Fig. 5).

Generally: V_{in} = 5V series I_{ave} =445mA (NKF0503S-1WR2 I_{ave} =450mA)
 V_{in} =12V series I_{ave} =205mA
 V_{in} =24V series I_{ave} =104mA
 V_{in} =48V series I_{ave} =53mA

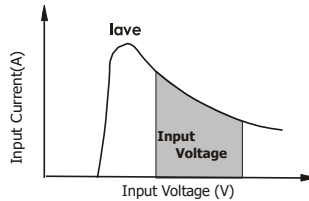

Fig. 5

5. Output load requirements

When using, the minimum load of the module output should not be less than 5% of the nominal load. In order to meet the performance parameters of this datasheet, please connect a 5% dummy load in parallel at the output end, the dummy load is generally a resistor, please note that the resistor needs to be used in derating.

Dimensions and Recommended Layout

THIRD ANGLE PROJECTION 

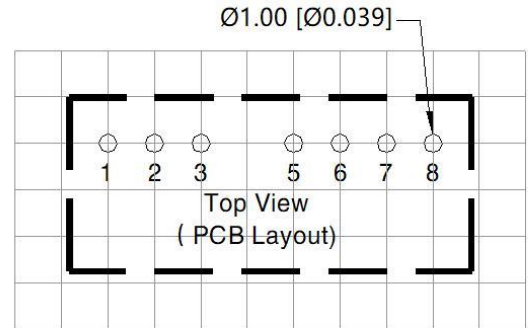
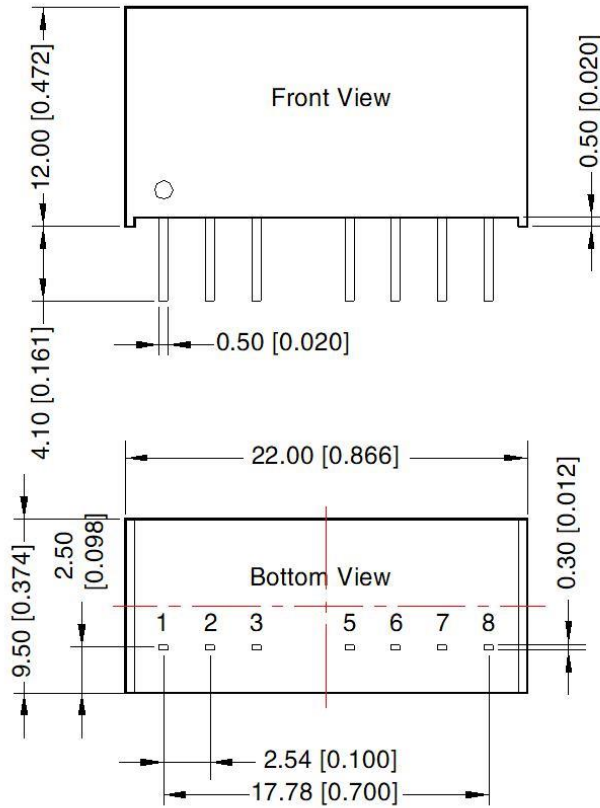

Note: Grid 2.54*2.54mm

Pin-Out		
Pin	Single	Dual
1	GND	GND
2	Vin	Vin
3	Ctrl	Ctrl
5	NC	NC
6	+Vo	+Vo
7	0V	0V
8	CS	-Vo

NC: Not available for electrical connection

Note:
 Unit: mm[inch]
 Pin section tolerances: ± 0.10 [± 0.004]
 General tolerances: ± 0.25 [± 0.010]

Note:

1. If the product works under the minimum required load, it cannot guarantee that the performance of the product complies with all the performance indicators in this manual;
2. The maximum capacitive load is tested under the input voltage range and full load condition;
3. Unless otherwise stated, all indexes in this manual are measured at Ta=25°C, humidity <75%RH, nominal input voltage and rated output load;
4. All index testing methods in this manual are based on the enterprise standards of the company;
5. Our company can provide product customization, specific needs can directly contact our technical staff.