

MODEL NO. : P1210SVF1MB00
SPEC VERSION: 1.3
ISSUED DATE: 2022/3/21

- Preliminary Specification
- Final Product Specification

Customer : _____

Approved by	Notes

TIANMA Confirmed :

Prepared by	Checked by	Approved by
Anna Huang	ZhuGuanchen	ShenHongyu

This technical specification is subjected to change without notice

TABLE OF CONTENTS

TABLE OF CONTENTS.....	2
RECORD OF VERSION.....	3
1 GENERAL SPECIFICATIONS	4
2 INPUT/OUTPUT TERMINALS.....	5
3 ABSOLUTE MAXIMUM RATINGS.....	8
4 ELECTRICAL CHARACTERISTICS.....	9
5 DISPLAY COLORS AND INPUT DATA SIGNALS.....	13
6 TIMING CHART.....	13
7 OPTICAL CHARACTERISTICS.....	20
8 ENVIRONMENTAL / RELIABILITY TEST.....	23
9 MECHANICAL DRAWING.....	24
10 MARKINGS.....	25
11 PACKING, TRANSPORTATION AND DELIVERY.....	27
12 PRECAUTIONS.....	29

RECORD OF REVISION

Rev	Issued Date	Description	Editor
1.0	2021-5-6	Preliminary Specification release	Anna Huang
1.1	2022-1-4	Update Optical Characteristics at P20 Update electrical characteristics at P10~11 Update mechanical drawing at P25 Update marking at P26 Update size and weight for packing at P28	Anna Huang
1.2	2022-1-21	Modify Pin19 NC definition	Anna Huang
1.3	2022-3-21	Chang Pin 19 NC=GND P5&P9	Anna Huang

AVIC CONFIDENTIAL

1 GENERAL SPECIFICATIONS

	Feature	Spec
Display Spec.	Size	12.1 inch
	Resolution	800xRGBx600
	Technology Type	SFT
	Pixel Configuration	RGB vertical stripe
	Pixel pitch(mm)	0.3075(H) × 0.3075(V)
	Display Mode	TM with Normally Black
	Surface Treatment	Anti Glare
	Viewing Direction	All
Mechanical Characteristics	LCM (W x H x D) (mm)	279.0 (H) × 209.0 (V) × 9.0 (D)
	Active Area(mm)	246.0 (H) × 184.5 (V) (typ.)
	With /Without TSP	Without TSP
	Connection Type	Socket
	Weight (g)	492
Electrical Characteristics	Interface	LVDS 1 port
	Color Depth	16.7M/262K

Note 1: Requirements on Environmental Protection: RoHS

Note 2: LCM weight tolerance: ± 5%

2 Input/Output Terminals

2.1 LVDS

CN1: MSB240420HE (Produced by STM) or equivalent.

Pin	Name	Description
1	VCC	3.3V Power Supply
2	VCC	3.3V Power Supply
3	GND	Ground
4	6-8Bit SET	Select 6 or 8 Bits LVDS Input (VCC:8Bits ; GND/NC: 6Bits)
5	RIN0-	Negative(-) LVDS differential data input
6	RIN0+	Positive(+) LVDS differential data input
7	GND	Ground
8	RIN1-	Negative(-) LVDS differential data input
9	RIN1+	Positive(+) LVDS differential data input
10	GND	Ground
11	RIN2-	Negative(-) LVDS differential data input
12	RIN2+	Positive(+) LVDS differential data input
13	GND	Ground
14	CLKIN-	Clock Signal(-)
15	CLKIN+	Clock Signal(+)
16	GND	Ground
17	RIN3-	Negative(-) LVDS differential data input (Used for 8Bits LVDS Input; NC for 6Bits)
18	RIN3+	Positive(+) LVDS differential data input (Used for 8Bits LVDS Input; NC for 6Bits)
19	REVERSE	Display Reversed Function (VCC: Display Reverse; GND/NC: Normal Display)
20	NC/GND	Test Function Pin(Do not set this pin to High)

2.2 BACKLIGHT

CN2: MSB24038P5 (Produced by STM) or equivalent.

Pin	Symbol	Signal Name
1	VDD	12V
2	GND	GND
3	Enable	5V-On / 0V-Off
4	Dimming	PWM Dimming
5	NC	NC

2.3 POSITION OF PLUGS AND A SOCKET

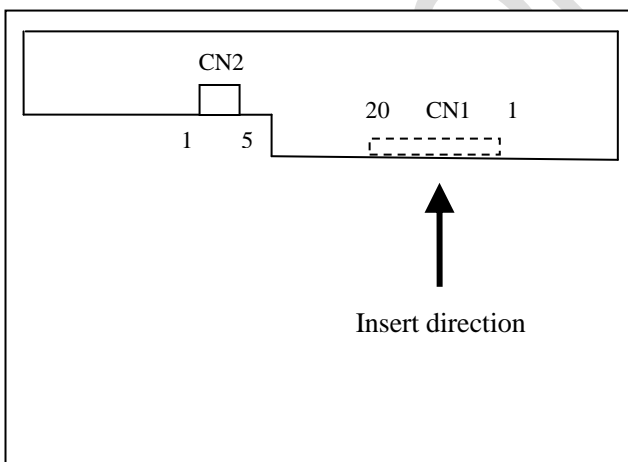

2.4 CONNECTION BETWEEN RECEIVER AND TRANSMITTER FOR LVDS

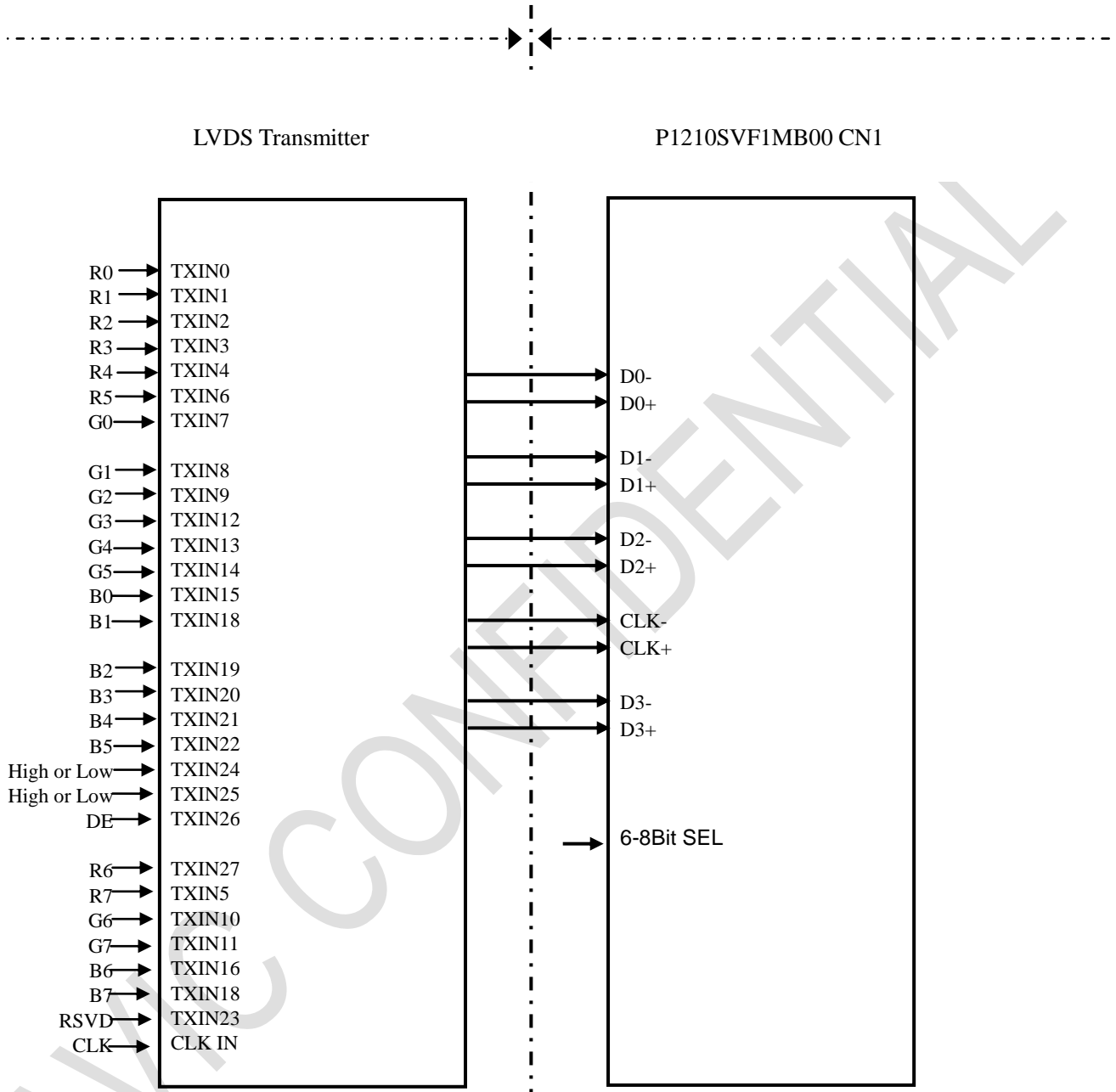

Note1: The lowest bit (R0, G0, B0), the upper bit (R7, G7, B7)

Note2: Connecting cable between LCD panel's connector and transmitter should use 100Ω twisted line.

Note3: If only Hsync and Vsync, the product don't work. Make sure DE signal has been input.

3 ABSOLUTE MAXIMUM RATINGS

Item	Symbol	Min	Max	Unit	Remark
LCD Power Voltage	VCC	-0.5	5.0	V	
Backlight Power Voltage	VDD	-0.3	33	V	
Backlight Input Voltage	V _{IN_BL}	-0.3	5.5	V	Note1
Operating Temperature	T _{OPR}	-20	70	°C	
Storage Temperature	T _{STG}	-30	80	°C	

Table 3.1 absolute maximum rating

Note1: Backlight Input voltage include Dimming, Enable.

4 Electrical Characteristics

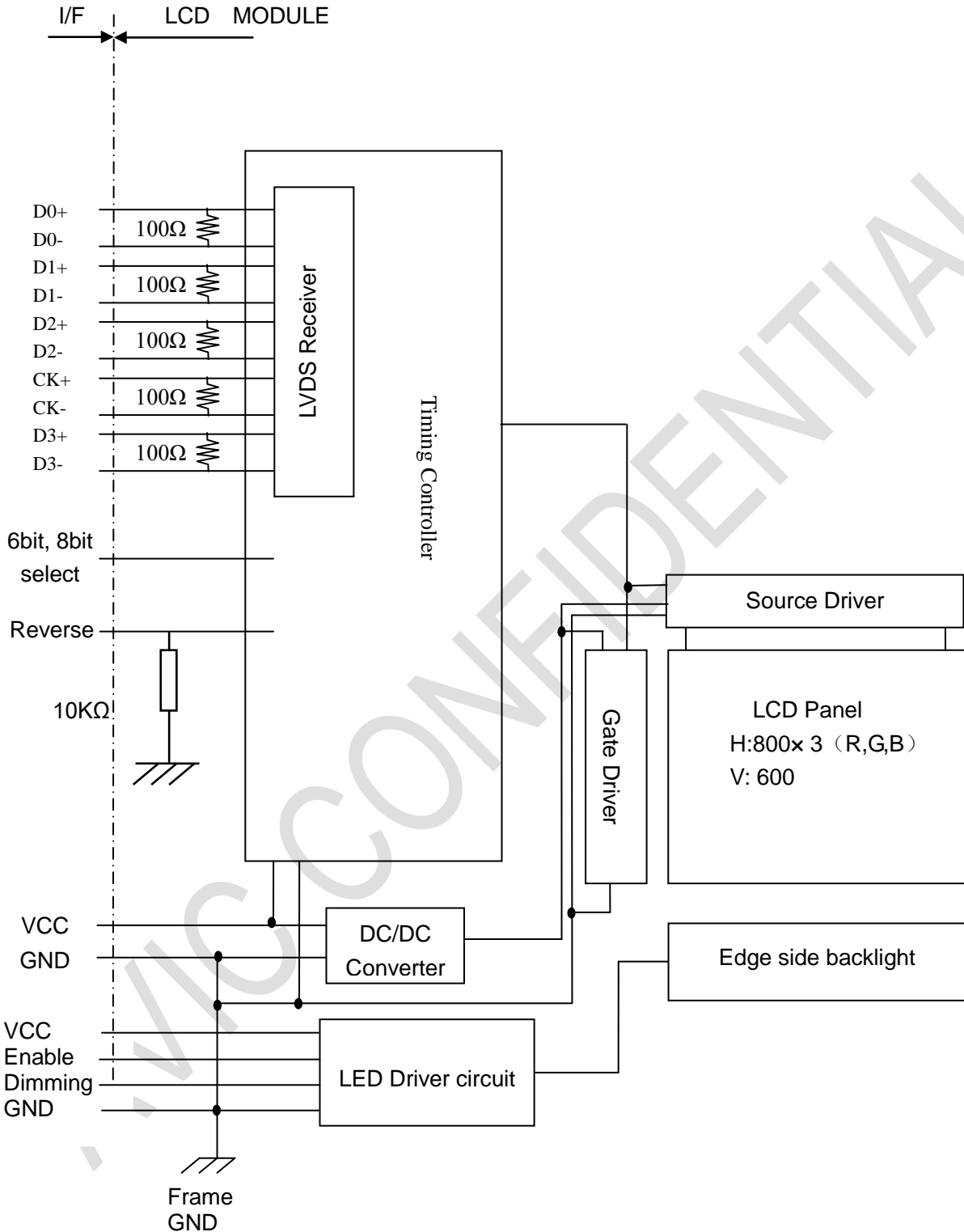

Note1: System ground (GND), Frame ground in the product should be connected together in customer equipment.

The information contained herein is the exclusive property of TIANMA MICRO-ELECTRONICS Corporation, and shall not be distributed, reproduced, or disclosed in whole or in part without prior written permission of TIANMA MICRO-ELECTRONICS Corporation.

4.1 DRIVING FOR LCD

Parameter	Symbol	min.	typ.	max.	Unit	Remarks
Power supply voltage	VCC	(3.0)	3.3	(3.6)	V	-
Power supply current	ICC	-	345	450	mA	at VCC = 3.3V Note 1
Permissible ripple voltage	VRP			200	mV	VCC
Rush current	I _{rush}			3	A	Note3

Note 1: All white pattern

Note 2: Common mode voltage for LVDS receiver

Note 3: Measurement Conditions:

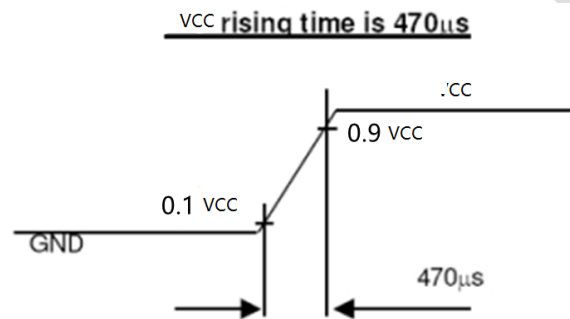

4.2 DRIVING FOR BACKLIGHT

(Ta=25 °C) Note1

Item	Symbol	Min	Typ	Max	Unit	Remark	
Backlight power supply voltage	VDD	11.8	12	13.2	V		
Backlight power supply current	I_Total	-	720	1000	mA	Note1	
Backlight power consumption	P_Total	-	8.64	12	W		
Input voltage for Dimming	High level	-	1.5	-	5	V	Input voltage for Dimming
	Low level	-	-	-	0.8	V	
Input voltage for Enable	High level	-	1.2	-	5	V	Input voltage for Enable
	Low level	-	-	-	0.35	V	
Dimming frequency	Fpwm	200	-	10K	HZ		
Dimming duty	D	5	-	100	%	Note2	
Inrush current	Inrush	-	-	4	A	Note5	
LED Life Time			50000		H	Note6	

Note 1: I_Total is the power supply current of LED driver, P_Total is the power consumption of LED driver and backlight.

Note 2: According to LED driver IC characteristics, the minimum value of VBR duty may vary with VBR frequency, higher the frequency, bigger the duty.

Note 3: Optical performance should be evaluated at Ta=70°C only with 100%PWM.

If LED is driven by high current, high ambient temperature & humidity condition. The life time of LED will be reduced.

Operating life means brightness goes down to 50% of initial brightness.

Operating life time is estimated data.

Note 4: Ta=25°C only with 100%PWM, the other condition should follow Note3.

Note 5: In-rush current test conditions:

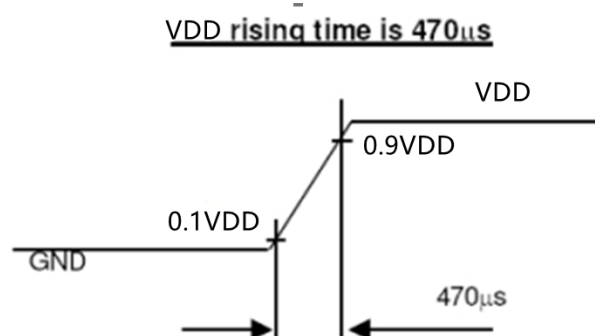

Note6: Optical performance should be evaluated at Ta=25°C. Only If LED is driven by high current, high ambient temperature & humidity condition. The life time of LED will be reduced. Operating life means brightness goes down to 50% of initial brightness. Typical operating life time is an estimated data.

4.3 TFT Block Diagram

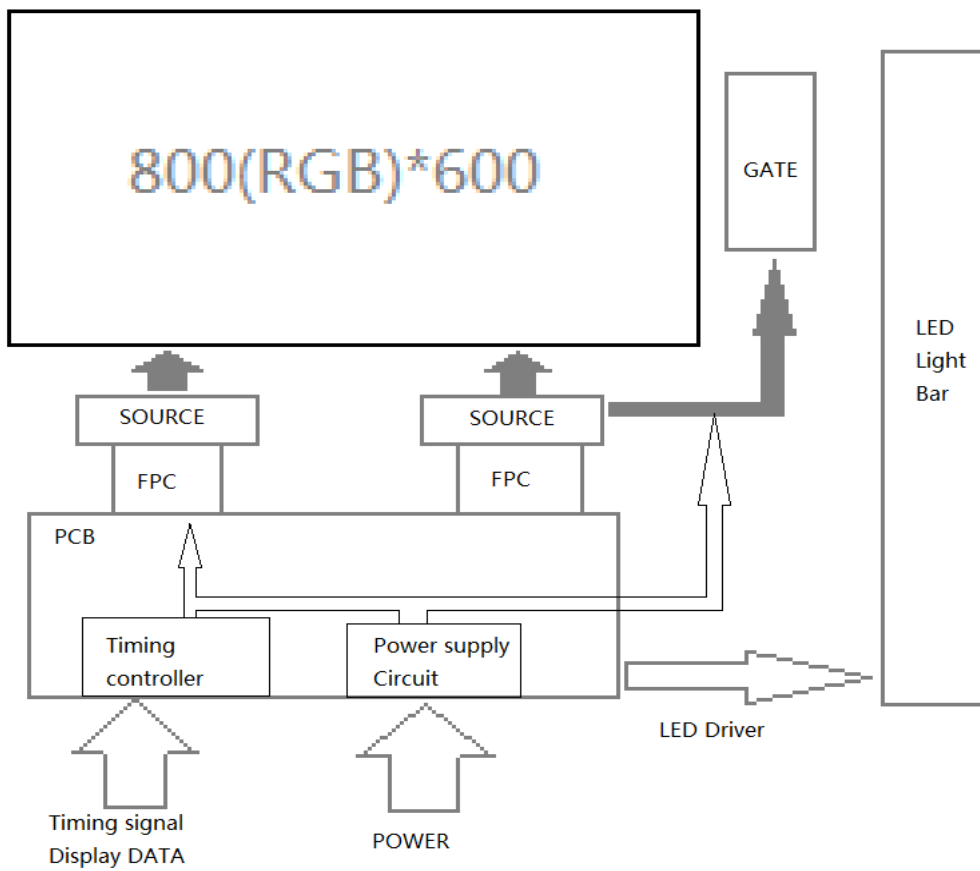

5 DISPLAY COLORS AND INPUT DATA SIGNALS

This product can display in equivalent to 16.7M colors in 256 scales. Also the relation between display colors and input data signals is as the following table.

Display colors		Data signal (0:Low level, 1:High Level)																							
		R7	R6	R5	R4	R3	R2	R1	R0	G7	G6	G5	G4	G3	G2	G1	G0	B7	B6	B5	B4	B3	B2	B1	B0
Basic Color	Black	0	0	0	0	0	0	0	0	0	0	0	0	0	0	0	0	0	0	0	0	0	0	0	0
	Blue	0	0	0	0	0	0	0	0	0	0	0	0	0	0	0	0	1	1	1	1	1	1	1	1
	Red	1	1	1	1	1	1	1	1	0	0	0	0	0	0	0	0	0	0	0	0	0	0	0	0
	Magenta	1	1	1	1	1	1	1	1	0	0	0	0	0	0	0	0	1	1	1	1	1	1	1	1
	Green	0	0	0	0	0	0	0	0	1	1	1	1	1	1	1	1	0	0	0	0	0	0	0	0
	Cyan	0	0	0	0	0	0	0	0	1	1	1	1	1	1	1	1	1	1	1	1	1	1	1	1
	Yellow	1	1	1	1	1	1	1	1	1	1	1	1	1	1	1	1	0	0	0	0	0	0	0	0
	White	1	1	1	1	1	1	1	1	1	1	1	1	1	1	1	1	1	1	1	1	1	1	1	1
Red grayscale	Black	0	0	0	0	0	0	0	0	0	0	0	0	0	0	0	0	0	0	0	0	0	0	0	0
	Dark	0	0	0	0	0	0	0	1	0	0	0	0	0	0	0	0	0	0	0	0	0	0	0	0
	↑	:																							
	↓	:																							
	Bright	1	1	1	1	1	1	0	1	0	0	0	0	0	0	0	0	0	0	0	0	0	0	0	0
	Red	1	1	1	1	1	1	1	0	0	0	0	0	0	0	0	0	0	0	0	0	0	0	0	0
Green grayscale	Black	0	0	0	0	0	0	0	0	0	0	0	0	0	0	0	0	0	0	0	0	0	0	0	0
	Dark	0	0	0	0	0	0	0	0	0	0	0	0	0	0	0	1	0	0	0	0	0	0	0	0
	↑	:																							
	↓	:																							
	Bright	0	0	0	0	0	0	0	0	1	1	1	1	1	1	0	1	0	0	0	0	0	0	0	0
	Green	0	0	0	0	0	0	0	0	1	1	1	1	1	1	1	0	0	0	0	0	0	0	0	0
Blue grayscale	Black	0	0	0	0	0	0	0	0	0	0	0	0	0	0	0	0	0	0	0	0	0	0	0	0
	Dark	0	0	0	0	0	0	0	0	0	0	0	0	0	0	0	0	0	0	0	0	0	0	0	1
	↑	:																							
	↓	:																							
	Bright	0	0	0	0	0	0	0	0	0	0	0	0	0	0	0	0	1	1	1	1	1	1	0	1
	Blue	0	0	0	0	0	0	0	0	0	0	0	0	0	0	0	0	1	1	1	1	1	1	1	0
		0	0	0	0	0	0	0	0	0	0	0	0	0	0	0	1	1	1	1	1	1	1	1	

6 TIMING Chart

6.1 DC Characteristics

Parameter	Symbol	Min	Typ.	Max.	Unit	Conditions
Power supply voltage	VCC	3.0	3.3	3.6	V	
Low level input voltage	VIL	0	-	0.3x VCC	V	CMOS I/F digital circuit
High level input voltage	VIH	0.7x VCC	-	VCC	V	CMOS I/F digital circuit
Input leakage current	ILEAK	-	-	+/-1	uA	CMOS I/F digital circuit
Pull low/high resistor	RPULL	180K	250K	320K	ohm	For the digital input pin @VCC=3.3V
Digital operation Current	IVCC	-	24	36	mA	F _{CLK} =45MHz, F _{LD} =48K @VCC=3.3V Data pattern=55/H -> AA/H (loop)

6.2 LVDS AC Electrical Characteristics

Parameter	Symbol	Min.	Typ.	Max.	Unit	Conditions
Clock Frequency	R _x FCLK	20		80	MHz	
Clock Period	R _x TCLK	12.5		50	ns	
1 data bit time	UI	-	1/7	-	R _x TCLK	
Clock high time	T _{LVCH}		4		UI	
Clock low time	T _{LVCL}		3		UI	
Position 1	T _{POS1}	-0.25	0	0.25	UI	
Position 2	T _{POS2}	0.75	-	1.25	UI	
Position 3	T _{POS3}	0.75	1	1.25	UI	
Position 4	T _{POS4}	1.75	-	2.25	UI	
Position 5	T _{POS5}	1.75	2	2.25	UI	
Position 6	T _{POS6}	2.75	-	3.25	UI	
Position 7	T _{POS7}	2.75	3	3.25	UI	
Position 8	T _{POS8}	3.75	-	4.25	UI	

The information contained herein is the exclusive property of TIANMA MICRO-ELECTRONICS Corporation, and shall not be distributed, reproduced, or disclosed in whole or in part without prior written permission of TIANMA MICRO-ELECTRONICS Corporation.

Position 9	T_{POS9}	3.75	4	4.25	UI	
Position 10	T_{POS10}	4.75	-	5.25	UI	
Position 11	T_{POS11}	4.75	5	5.25	UI	
Position 12	T_{POS12}	5.75	-	6.25	UI	
Position 13	T_{POS13}	5.75	6	6.25	UI	
Position 14	T_{POS14}	6.75	-	7.25	UI	
Input eye width	T_{EYEW}	0.5	-	-	UI	
Input eye border	T_{EX}	-	-	0.25	UI	

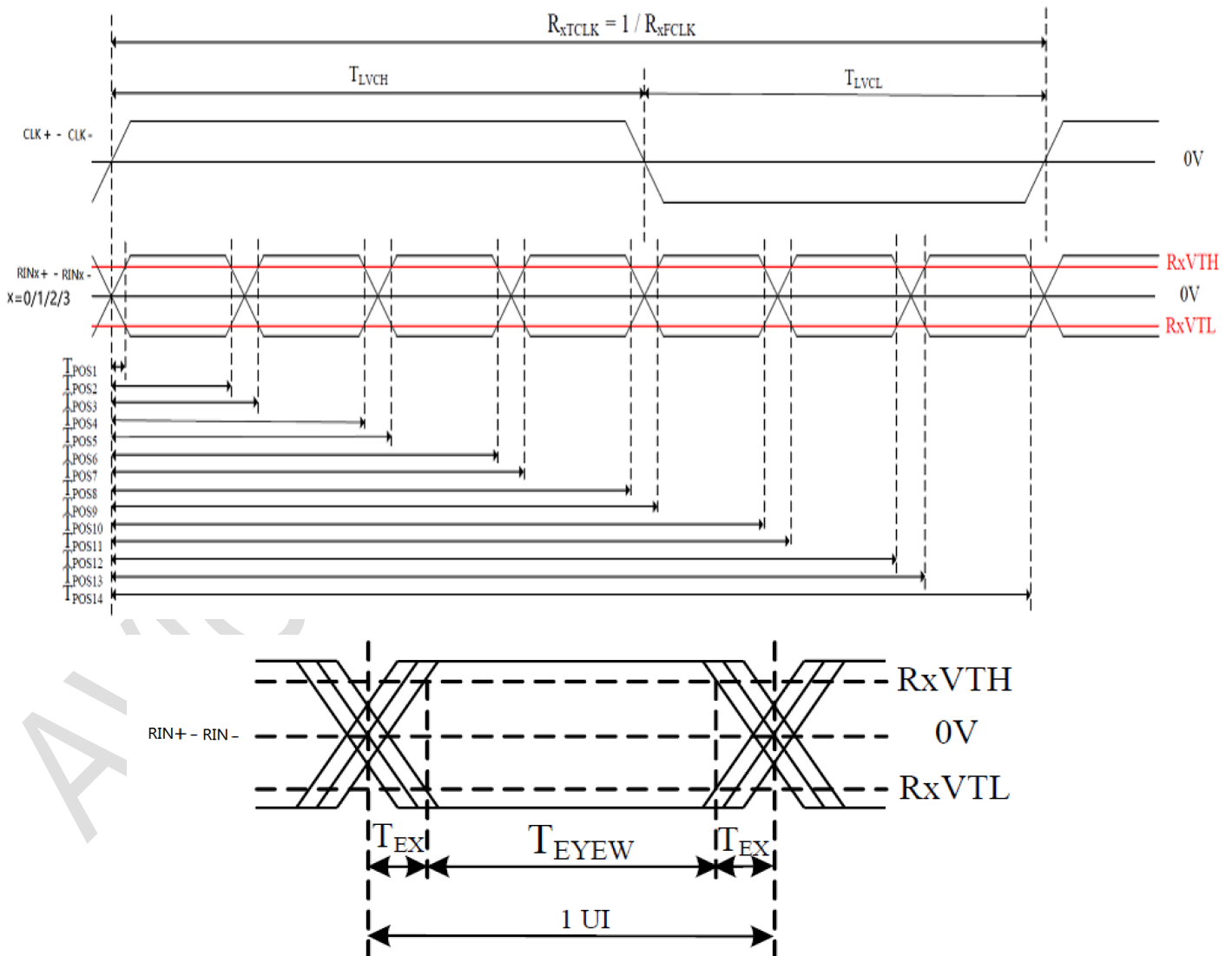

6.3 LVDS DC Electrical Characteristics

 $V_{CC}=3.3V, GND=0V, T_a=25^{\circ}C$

Parameter	Symbol	Min.	Typ.	Max.	Unit	Remark
Differential input high Threshold voltage	R_{XVTH}			0.1	V	
Differential input Low Threshold voltage	R_{XVTL}	-0.1			V	
Input voltage range(single-end)	R_{XVIN}	0		$V_{CC}-1.0$	V	
Differential input common Mode voltage	R_{XVCM}	0.6	1.2	$2.4- V_{ID} /2$	V	
Differential input voltage	$ V_{ID} $	0.2	0.4	0.6	V	
Differential input leakage current	R_{Vxliz}	-10		10	μA	

Single end signals

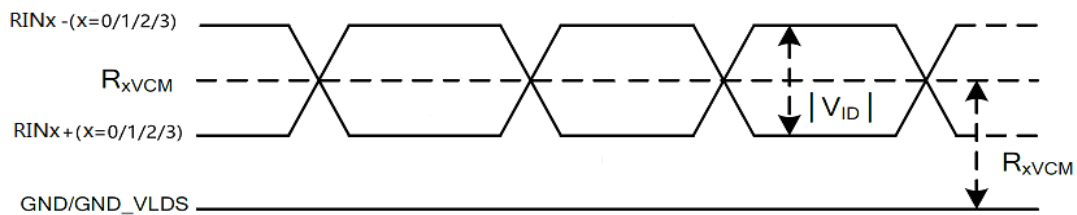

Differential signals

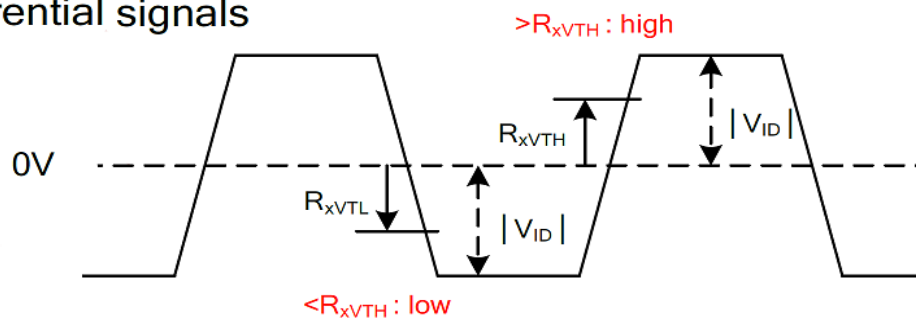

6.4 Input timing

Parameter	Symbol	MIN	Typ	MAX	Unit	Remark
CLK frequency	tclk	30.38	31.63	40.27	MHz	
Horizontal display area	thd	800			tclk	
Horizontal pulse width	thpw	2	2	8	tclk	
Horizontal back porch	thbp	8	16	40	tclk	
Horizontal front porch	thfp	16	16	100	tclk	
HSYNC period	th	826	834	948	tclk	
Vertical display area	tvd	600			th	
Vertical plus width	tvpw	2	2	8	th	
Vertical back porch	tvbp	3	10	40	th	
Vertical front porch	tvfp	8	20	60	th	
VSD period	tv	613	632	708	th	
Frame rate	FR	60			Hz	

Vertical input timing

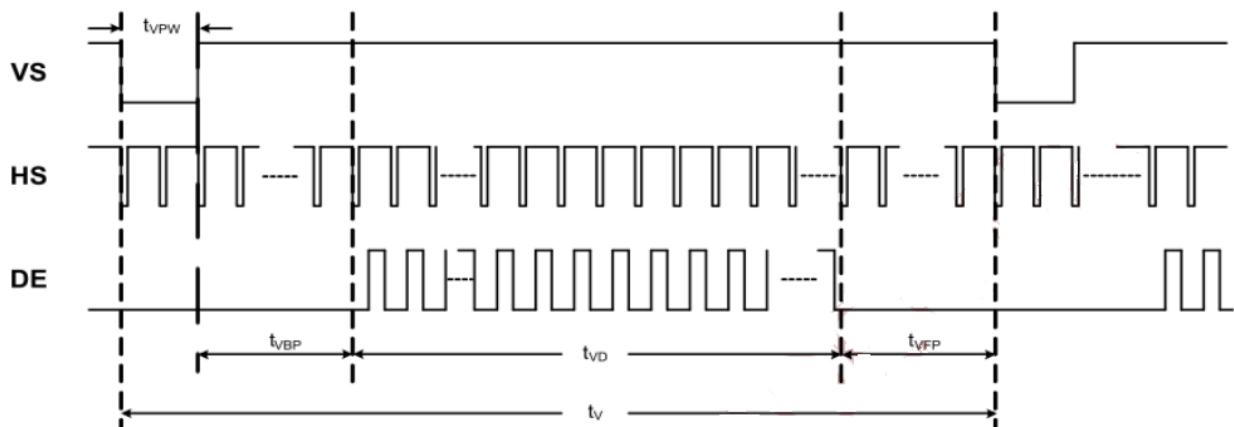

Horizontal input timing

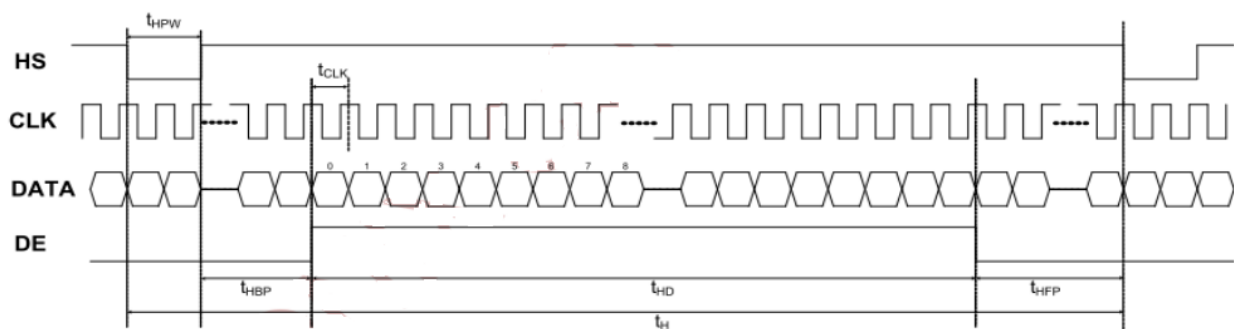

6.5 Data Input Format VESA Data Mapping

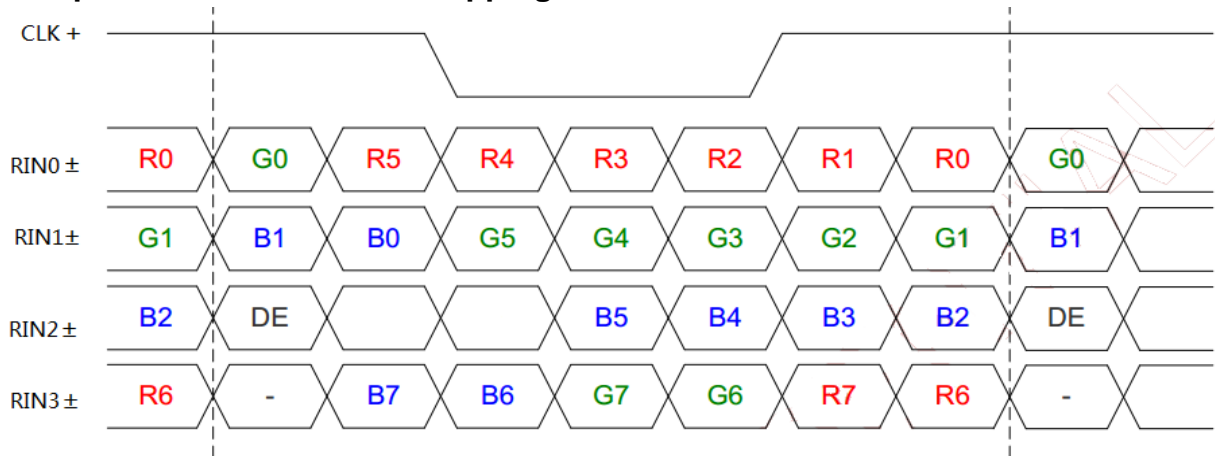

6.6 Power On/Off Timing

Item	Symbol	MIN	Typ	MAX	Unit	Remark
VCC on to VCC stable	Tp1	0.5	-	3	ms	
VCC stable to signal on	Tp2	20	-	100	ms	
Signal stable to ENABLE(BL_EN) on	Tp3	200	-	-	ms	
Dimming(BL_PWM) on to ENABLE(BL_EN) on	Tp4	0	-	200	ms	
VDD to Dimming(BL_PWM) on	Tp5	10	-	-	ms	
VDD on to VDD stable	Tp6	0.5	-	10	ms	
VCC off time	Tp7	0.5	-	10	ms	
VCC off to next VCC on	Tp8	500	-	-	ms	
Signal off before VCC off	Tp9	123	-	500	ms	
ENABLE(BL_EN) off before signal off	Tp10	200	-	-	ms	
ENABLE(BL_EN) off before Dimming(BL_PWM) off	Tp11	0	-	200	ms	
Dimming(BL_PWM) off before VDD off	Tp12	10	-	-	ms	

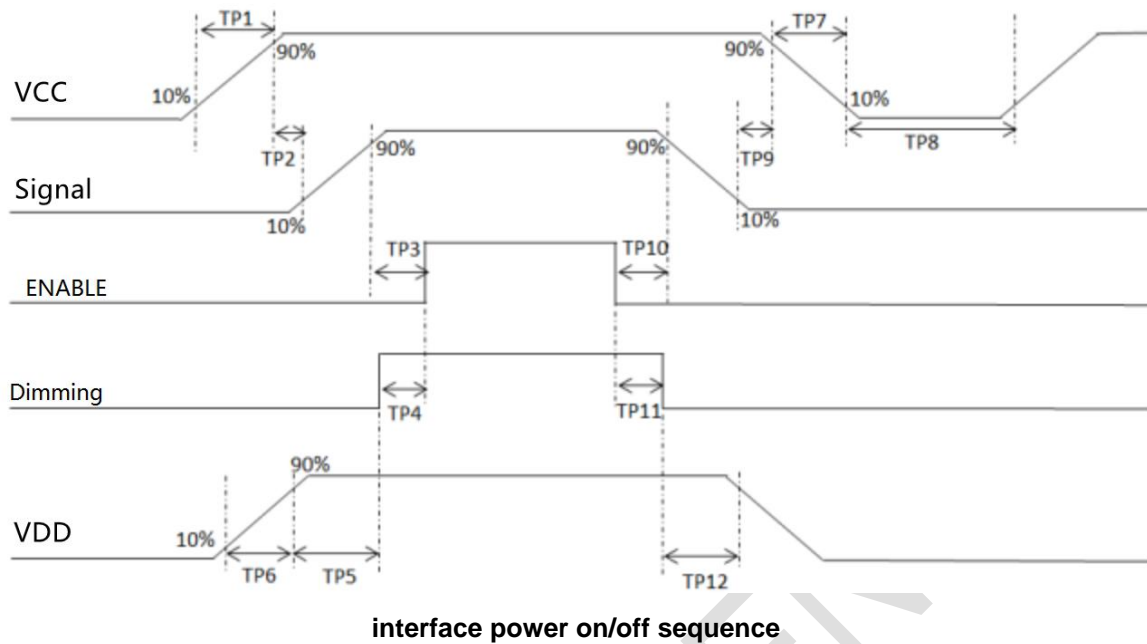

interface power on/off sequence

6.4.3 Fuse

Parameter	Fuse		Rating	Fusing current	Remarks
	Type	Supplier			
VCC	FCC16152ABTP	KAMAYA	1.5A 32V	3.0A/5smax	Note1
VDD	FCC16202ABTP	KAMAYA	2A 32V	4.0A/5smax	Note1

Note1: There are different power supply systems from the power input terminal. The power supply capacity should be less than the fusing current. If the power supply capacity is above the fusing current, the fuse may blow in a short time, and then nasty smell, smoking and so on may occur.

7 Optical Characteristics

Item	Symbol	Condition	Min	Typ.	Max	Unit	Remark	
View Angles	θT	$CR \geq 10$	80	88	-	Degree	Note 2	
	θB		80	88	-			
	θL		80	88	-			
	θR		80	88	-			
Contrast Ratio	CR	$\theta=0^\circ$		1000	-	-	Note1 Note3	
Luminance uniformity	U		70		%	-	Note6	
Response Time	T_{ON}	25°C	-	25	35	ms	Note1	
	T_{OFF}						Note4	
Chromaticity	White	Backlight is on	x	0.252	0.302	0.352	-	Note5 Note1
			y	0.281	0.331	0.381		
	Red		x	0.586	0.636	0.686		
			y	0.285	0.335	0.385		
	Green		x	0.239	0.289	0.339		
			y	0.565	0.615	0.665		
	Blue		x	0.101	0.151	0.201		
			y	0.011	0.061	0.111		
NTSC				72	-	%	Note5	
Luminance	L			500	-	cd/m ²	Note7	

Test Conditions:

- The ambient temperature is 25°C. VDD= 3.3V, VCC=12V, 100% brightness,
- The test systems refer to Note 1 and Note2.

Note 1: Definition of optical measurement system.

The optical characteristics should be measured in dark room. After 5 Minutes operation, the optical properties are measured at the center point of the LCD screen. All input terminals LCD panel must be ground when measuring the center area of the panel.

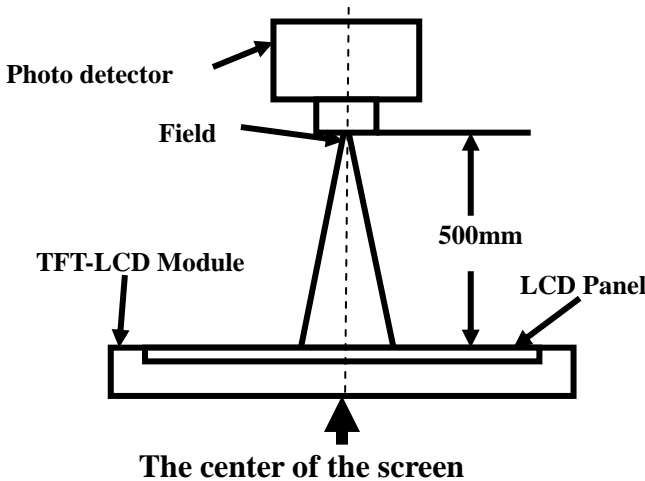

Note 2: Definition of viewing angle range and measurement system.

viewing angle is measured at the center point of the LCD by CONOSCOPE(ergo-80).

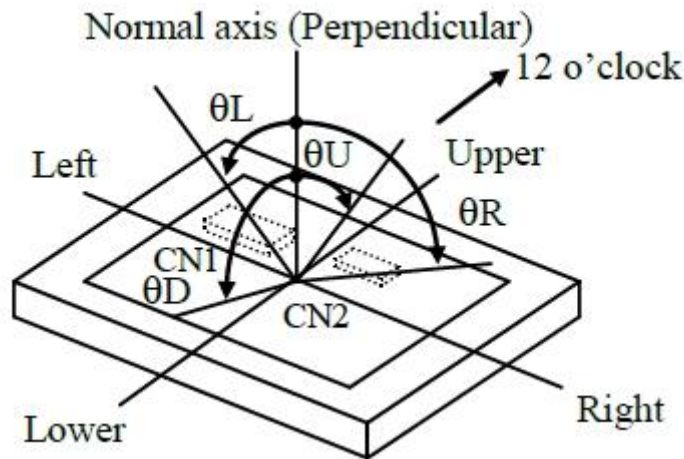

Note 3: Definition of contrast ratio

$$\text{Contrast ratio (CR)} = \frac{\text{Luminance measured when LCD is on the "White" state}}{\text{Luminance measured when LCD is on the "Black" state}}$$

“White state “: The state is that the LCD should drive by V_{white} .

“Black state”: The state is that the LCD should drive by V_{black} .

V_{white} : To be determined V_{black} : To be determined.

Note 4: Definition of Response time

The response time is defined as the LCD optical switching time interval between “White” state and “Black” state. Rise time (T_{ON}) is the time between photo detector output intensity changed from 90% to 10%. And fall time (T_{OFF}) is the time between photo detector output intensity changed from 10% to 90%.

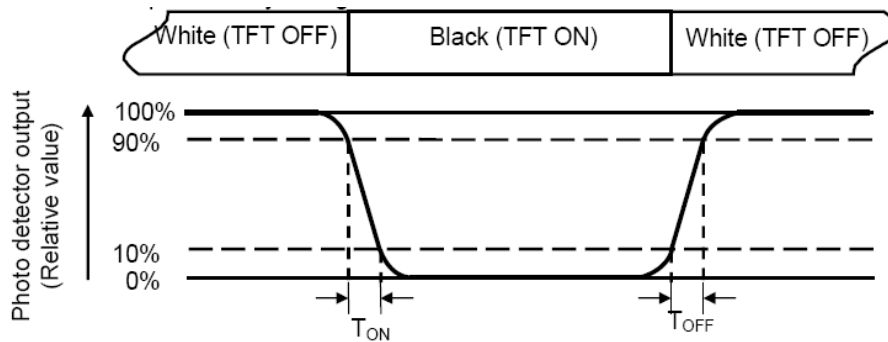

Note 5: Definition of color chromaticity (CIE1931)

Color coordinates measured at center point of LCD.

Note 6: Definition of Luminance Uniformity

Active area is divided into 9 measuring areas (Refer Fig. 2). Every measuring point is placed at the center of each measuring area.

$$\text{Luminance Uniformity (U)} = L_{\min} / L_{\max}$$

L-----Active area length W----- Active area width

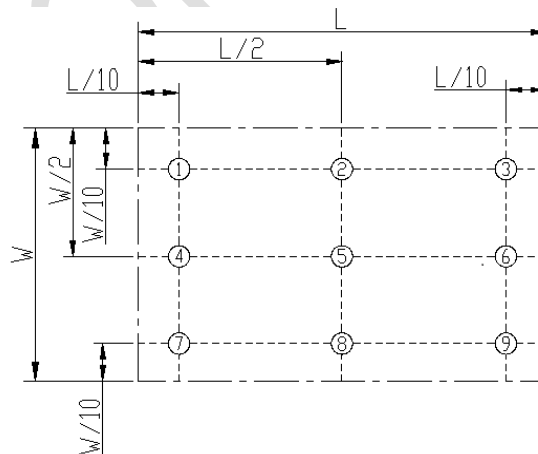

L_{\max} : The measured Maximum luminance of all measurement position.

L_{\min} : The measured Minimum luminance of all measurement position.

Note 7: Definition of Luminance:

Measure the luminance of white state at center point.

8 Environmental / Reliability Test

No.	Test Item	Condition	Remark
1	High Temperature & High Humidity Operation	60°C, 90%RH, 240hrs	IEC60068-2-78 GB/T2423.3
2	High Temperature Storage	+80°C, 240hrs	IEC60068-2-1 GB2423.2
3	Low Temperature Storage	-30°C, 240hrs	EC60068-2-1 GB2423.1
4	High Temperature Operation	+70°C, 240hrs	IEC60068-2-1,GB2423.2
5	Low Temperature Operation	-20°C, 240hrs	IEC60068-2-1 GB2423.1
6	Thermal Shock (Non-operation)	-30°C,30min;80°C,30min;1H/cycle, Change time:5min, 100 Cycles	Start with cold temperature nd with high temperature, EC60068-2-14,GB2423.22
7	Vibration	10~55HZ Stroke:1.5mm Sweep:10HZ~55HZ~10HZ 2H For X\Y\Z	IEC60068-2-6:1982 GB/T2423.10—1995
8	Package condition	5-20 -200HZ, PSD : 0.01-0.01 -0.001 Total:0.781g2/HZ, ,x/y/z every direction every direction 30min)	
9	ESD	150PF、330Ω 5points、5times Air: ±8KV Connect: ±4KV	IEC61000-4-2 GB/T17626.2

9 Mechanical Drawing

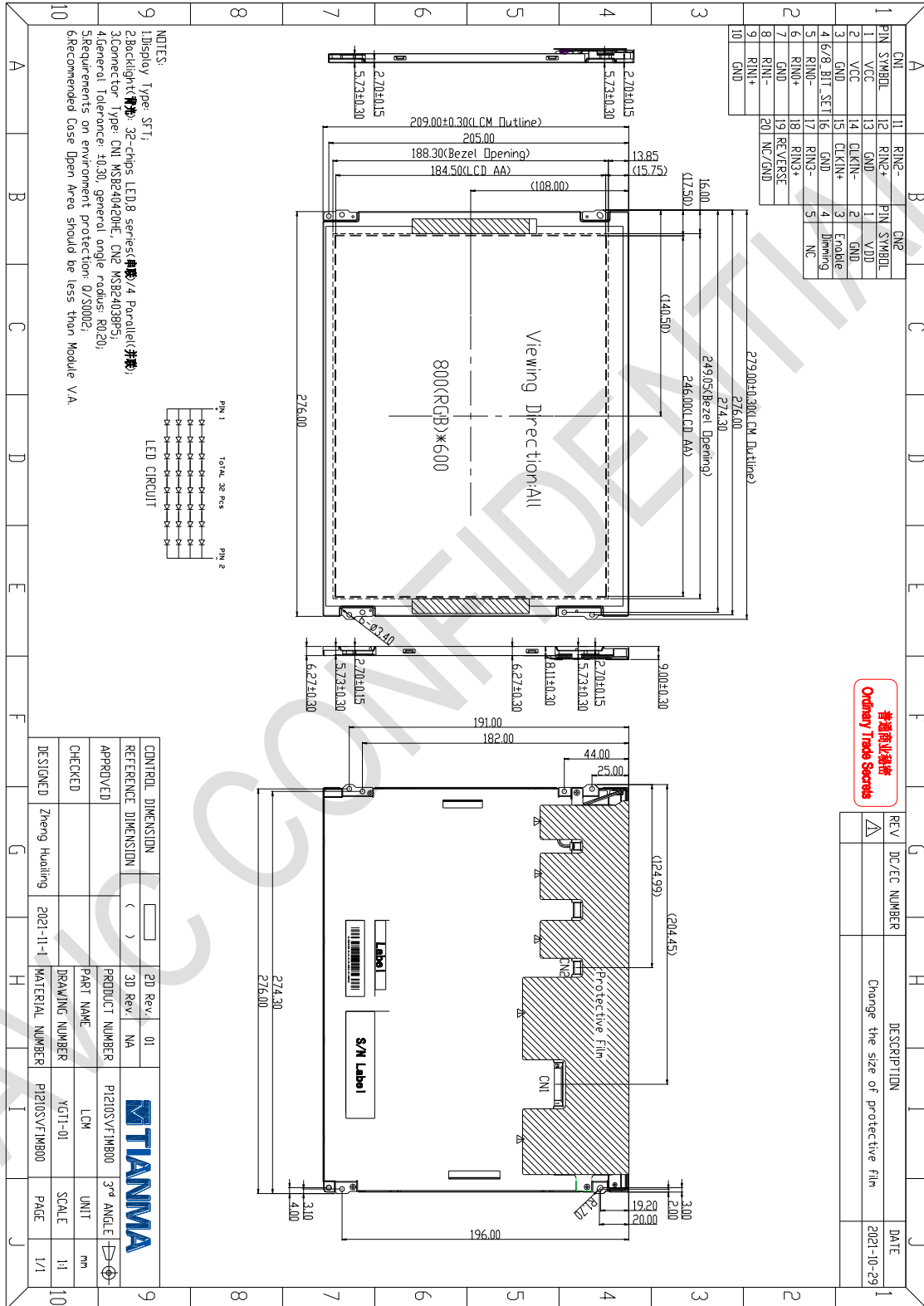

普通商业机密
Ordinary Trade Secrets

REV	DC/EC NUMBER	DESCRIPTION	DATE
Δ		Change the size of protective film	2021-10-29

CONTROL DIMENSION	2D Rev.	01
REFERENCE DIMENSION	()	3D Rev. NA
APPROVED	PRODUCT NUMBER	P1210SVF1MB00
CHECKED	PART NAME	LCH
DESIGNED	DRAWING NUMBER	YG11-01
	MATERIAL NUMBER	P1210SVF1MB00
	UNIT	mm
	SCALE	1:1
	PAGE	1/1

10 MARKINGS

The various markings are attached to this product. See “11.2 INDECATION LOCATIONS” for attachment positions.

10.1 PRODUCT LABEL (TBD)

UL MARK (After certification, we will add it)



ROHS Mark

Note1: The meaning of OEM number, Example:

LOT NO : SR1AM0B12

SR	1	A	M	0	B	12
Rev: SR or A Sample: SR Mp:A	Year: 0~9	Month: 1~9,A,B,C	Line	Srank	Day: 1~9,A~V	Serial No: 11~19,1A~1Z,2A~2ZA1.....ZZ

SN: 116180581510---panel SN

1	1	6	18	058	15	10
Line: 1~	Year: 0~9	Month: 1~9,A,B,C	Day: 1~31	Serial: 001~999, Except I、S、O	Sheet No: 01~20	Sheet area

10.2 INDICATION LOCATIONS

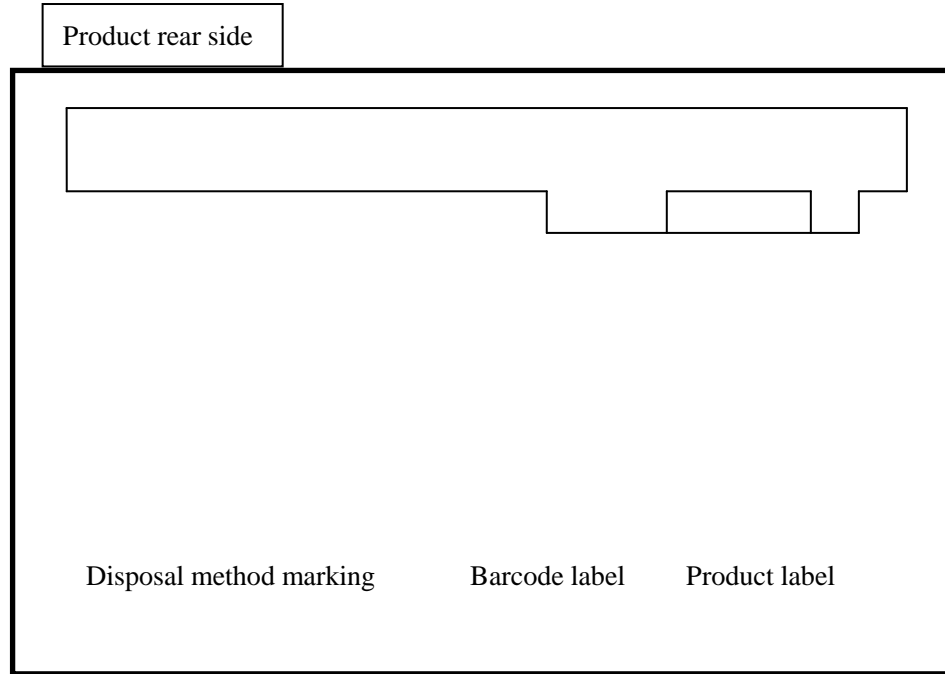

11 PACKING, TRANSPORTATION AND DELIVERY

AVIC will pack products to deliver to customer in accordance with AVIC packing specifications, and will deliver products to customer in such a state that products will not suffer from a damage during transportation .The delivery conditions are as follows.

11.1 PACKING

(1) Packing box

8 products are packed up with the maximum in a packing box(See “**12.5 OUTLINE FIGURE FOR PACKING** “). Products are put into a plastic bag for prevention of moisture with cushion, and then the bag is sealed up with heat sealing.

The type name and quality are shown on outside of the packing box, either labeling or printing.

(2) Pallet Packing (See”**12.5 OUTLINE FIGURE FOR PACKING** “)

- ① Packing boxes are tied on a cardboard pallet.(8 boxes×4 tiers maximum)
- ② Cardboard sleeve and top cap are attached to the packing boxes, then they are fixed by a band.

11.2 INSPECTION RECORD SHEET

Inspection record sheets are included in the packing box with delivery products to customer. It is summarized to a number of products for pass/fail assessment.

11.3 TRANSPORTATION

The product is transported by vehicle, aircraft or shipment in the state of pallet packing.

11.4 SIZE AND WEIGHT FOR PACKING BOX

Parameter	Packing box	Unit
Size	577 (L) ×421 (W) ×326 (H) (typ.)	mm
LCD Weight	0.492±5% (typ.)	kg
Total weight	14.48 (typ.)	kg

11.5 OUTLINE FIGURE FOR PACKING

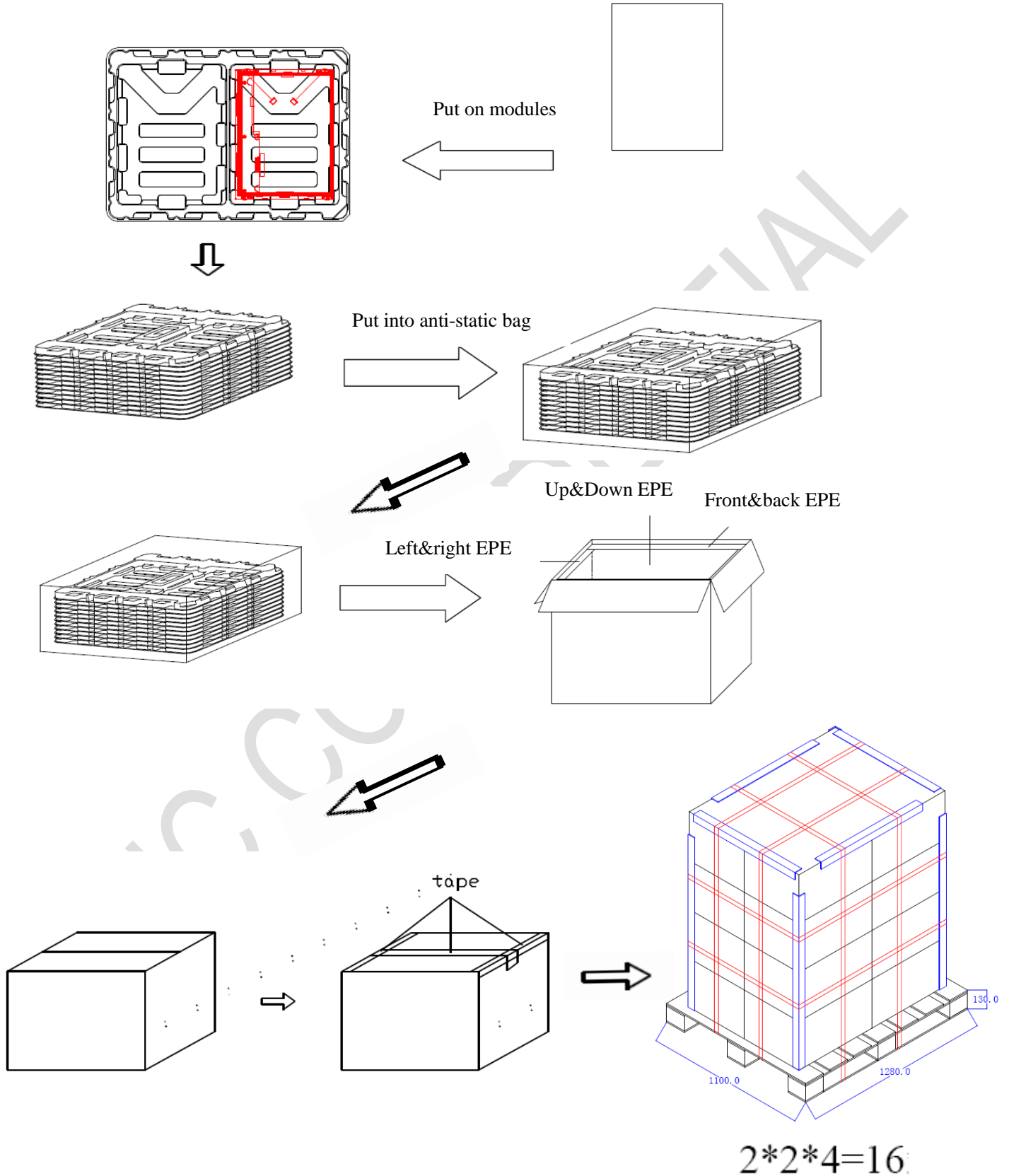

12 PRECAUTIONS

12.1 Handling Precautions

12.1.1 The display panel is made of glass. Do not subject it to a mechanical shock by dropping it from a high place, etc.

12.1.2 If the display panel is damaged and the liquid crystal substance inside it leaks out, be sure not to get any in your mouth, if the substance comes into contact with your skin or clothes, promptly wash it off using soap and water.

12.1.3 Do not apply excessive force to the display surface or the adjoining areas since this may cause the color tone to vary.

12.1.4 The polarizer covering the display surface of the LCD module is soft and easily scratched. Handle this polarizer carefully.

12.1.5 If the display surface is contaminated, breathe on the surface and gently wipe it with a soft dry cloth. If still not completely clear, moisten cloth with one of the following solvents:

- Isopropyl alcohol
- Ethyl alcohol

Solvents other than those mentioned above may damage the polarizer. Especially, do not use the following:

- Water
- Ketone
- Aromatic solvents

12.1.6 Do not attempt to disassemble the LCD Module.

12.1.7 If the logic circuit power is off, do not apply the input signals.

12.1.8 To prevent destruction of the elements by static electricity, be careful to maintain an optimum work environment.

12.1.8.1 Be sure to ground the body when handling the LCD Modules.

12.1.8.2 Tools required for assembly, such as soldering irons, must be properly ground.

12.1.8.3 To reduce the amount of static electricity generated, do not conduct assembly and other work under dry conditions.

12.1.8.4 The LCD Module is coated with a film to protect the display surface. Be care when peeling off this protective film since static electricity may be generated.

12.2 Storage precautions

12.2.7 When storing the LCD modules, avoid exposure to direct sunlight or to the light of fluorescent lamps.

12.2.8 The LCD modules should be stored under the storage temperature range. If the LCD modules will be stored for a long time, the recommend condition is:

Temperature : 0℃ ~ 40℃ Relatively humidity: ≤80%

12.2.9 The LCD modules should be stored in the room without acid, alkali and harmful gas.

12.3 Transportation Precautions

12.3.7 The LCD modules should be no falling and violent shocking during transportation, and also should avoid excessive press, water, damp and sunshine.

12.4 Do not display the fixed pattern for a long time because it may cause image sticking. Use a screen saver, if the fixed pattern is displayed on the screen

12.5 Safety Precautions

12.5.1. When you waste damaged or unnecessary LCDs, it is recommended to crush LCDs into pieces and wash them off with solvents such as acetone and ethanol, which should later be burned.

12.5.2. If any liquid leaks out of a damaged glass cell and comes in contact with the hands, wash off thoroughly with soap and water.

12.5.3. Be sure to turn off the power supply when inserting or disconnecting the LED backlight cable.

d. LED driver should be designed carefully to limit or stop its function when over current is detected on the LED.