



# Product Specification

AU OPTRONICS CORPORATION

( ) Preliminary Specifications

(✓) Final Specifications

<b>Module</b>	15.6" FHD Color TFT-LCD
<b>Model Name</b>	G156HTN02.0
<b>Note</b>	LED backlight with driving circuit design

<b>Customer</b>	<b>Date</b>
<b>Checked &amp; Approved by</b>	<b>Date</b>
Note: This Specification is subject to change without notice.	

<b>Approved by</b>	<b>Date</b>
<u>Crystal Hsieh</u>	<u>04/18/2016</u>
<b>Prepared by</b>	<b>Date</b>
<u>Sandy Su</u>	<u>04/18/2016</u>
<b>GDBU Marketing Division AU Optronics Corporation</b>	



# Product Specification

AU OPTRONICS CORPORATION

## Contents

<b>1. Handling Precautions</b>	<b>4</b>
<b>2. General Description</b>	<b>5</b>
2.1 General Specification	5
2.2 Optical Characteristics	6
<b>3. Functional Block Diagram</b>	<b>10</b>
<b>4. Absolute Maximum Ratings</b>	<b>11</b>
4.1 Absolute Ratings of TFT LCD Module	11
4.2 Absolute Ratings of Environment	11
<b>5. Electrical Characteristics</b>	<b>12</b>
5.1 TFT LCD Module	12
5.1.1 Power Specification	12
5.1.2 Signal Electrical Characteristics	13
5.2 Backlight Unit	14
<b>6. Signal Interface Characteristic</b>	<b>15</b>
6.1 Pixel Format Image	15
6.2 The Input Data Format	16
6.3 Signal Description	17
6.4 Interface Timing (LVDS)	18
6.5 Power ON/OFF Sequence	19
<b>7. Connector &amp; Pin Assignment</b>	<b>20</b>
7.1 TFT LCD Module	20
7.2 Backlight Unit	20
<b>8. Panel Reliability Test</b>	<b>22</b>
<b>9. Shipping and Package</b>	<b>23</b>
9.1 Shipping Label Format	23
9.2 Carton Package	23
9.3 Shipping Package of Palletizing Sequence	24
<b>10. Handling guide</b>	<b>25</b>
<b>11. Mechanical Characteristics</b>	<b>27</b>
11.1 LCM Outline Dimension (Front View)	27
11.2 LCM Outline Dimension (Rear View)	28



# Product Specification

AU OPTRONICS CORPORATION

## Record of Revision

Version and Date	Page	Old Description	New Description	Remark
0.0 2015/05/15	All	1 <sup>st</sup> Edition for Customers		
1.0 2016/04/18	5	Luminance Uniformity: TBD Contrast Ratio: 500:1 LCD Power Consumption: 3.76 LED Power Consumption: 10.6 Weight: TBD Support Color: 16.2M (6-bits +2FRC)	→Delete →700:1 →3.37 →10.5 →940 (Typ.) 1100 (Max.) →16.7M (RGB 8-bits)	
	6	Viewing Angle R/L/U/L: Min.60/60/45/50;Typ.70/70/60/60 Luminance Uniformity 5 Points:TBD 13 Points: TBD Contrast Ratio: Min.400; Typ.500 Color Coordinates: TBD	→Min.70/70/60/60;Typ.80/80/70/70 Update 9 point: Min.62; Typ.70 →Delete → Min.500; Typ.700 → Value	
	13	Power Specification PDD Typ: 3.14 Max:3.76 IDD Typ: 950; Max:1140 IRush Max: TBD VDDrp Max: TBD	→ Typ: 2.8; Max: 3.37 → Typ: 850; Max: 1020 →2500 →200	
	15	Backlight Power Consumption: Max:10.6 Backlight input signal characteristics: NA NA	→10.5  Add LED Input Current: Typ 0.73; Max0.88 Add LED Inrush Current: Max: 2	
	26	NA	Add Handling guide	
	29	LCM Outline Dimension (Rear View)	Update	



# Product Specification

AU OPTRONICS CORPORATION

## 1. Handling Precautions

- 1) Since front polarizer is easily damaged, please be cautious and not to scratch it.
- 2) Be sure to turn off power supply when inserting or disconnecting from input connector.
- 3) Wipe off water drop immediately. Long contact with water may cause discoloration or spots.
- 4) When the panel surface is soiled, wipe it with absorbent cotton or soft cloth.
- 5) Since the panel is made of glass, it may be broken or cracked if dropped or bumped on hard surface.
- 6) To avoid ESD (Electro Static Discharge) damage, be sure to ground yourself before handling TFT-LCD Module.
- 7) Do not open nor modify the module assembly.
- 8) Do not press the reflector sheet at the back of the module to any direction.
- 9) In case if a module has to be put back into the packing container slot after it was taken out from the container, do not press the center of the LED light bar edge. Instead, press at the far ends of the LED light bar edge softly. Otherwise the TFT Module may be damaged.
- 10) At the insertion or removal of the Signal Interface Connector, be sure not to rotate nor tilt the Interface Connector of the TFT Module.
- 11) TFT-LCD Module is not allowed to be twisted & bent even force is added on module in a very short time. Please design your display product well to avoid external force applying to module by end-user directly.
- 12) Small amount of materials without flammability grade are used in the TFT-LCD module. The TFT-LCD module should be supplied by power complied with requirements of Limited Power Source (IEC60950 or UL1950), or be applied exemption.
- 13) Severe temperature condition may result in different luminance, response time and lamp ignition voltage.
- 14) Continuous operating TFT-LCD display under low temperature environment may accelerate lamp exhaustion and reduce luminance dramatically.
- 15) The data on this specification sheet is applicable when LCD module is placed in landscape position.
- 16) Continuous displaying fixed pattern may induce image sticking. It's recommended to use screen saver or shuffle content periodically if fixed pattern is displayed on the screen.



# Product Specification

AU OPTRONICS CORPORATION

## 2. General Description

G156HTN02.0 is a Color Active Matrix Liquid Crystal Display composed of a TFT LCD panel, a driver circuit, and LED backlight system. The screen format is intended to support the 16:9 FHD, 1920(H) x1080(V) screen and 16.7M colors (RGB 8-bits data driver) with LED backlight driving circuit.

G156HTN02.0 is designed for a display unit of industrial machine.

### 2.1 General Specification

The following items are characteristics summary on the table at 25 °C condition:

Items	Unit	Specifications			
Screen Diagonal	[inch]	15.6"			
Active Area	[mm]	344.16(H) x 193.59(V)			
Pixels H x V		1920 x 3(RGB) x 1080			
Pixel Pitch	[mm]	0.17925 x 0.17925			
Pixel Format		R.G.B. Vertical Stripe			
Display Mode		TN Mode, Normally White			
White Luminance ( Center ) (ILED=50mA,Note: ILED is LED current)	[cd/m <sup>2</sup> ]	400 Typ. 320 Min.			
Contrast Ratio		700:1 (Typ.)			
Response Time	[ms]	8 (Typ.)/ 16 (Max.)			
Nominal Input Voltage VDD	[Volt]	+3.3 (Typ.)			
LCD Power Consumption	[Watt]	3.37 W (Max.)			
LED Power Consumption	[Watt]	10.5 W (Max.)			
Weight	[Grams]	940 (Typ.); 1100 (Max.)			
Physical Size Without bracket.	[mm]		Min.	Typ.	Max.
		Length	363.3	363.8	364.3
		Width	215.4	215.9	216.4
		Thickness	8.8	9.3	9.8
Electrical Interface		Two channel LVDS			
Surface Treatment		Anti-glare, 3H			
Support Color		16.7M Colors ( RGB 8-bits)			
Temperature Range					
Operating	[°C]	-10 to +70			
Storage (Non-Operating)	[°C]	-20 to +70			



# Product Specification

AU OPTRONICS CORPORATION

## 2.2 Optical Characteristics

The optical characteristics are measured under stable conditions at 25°C (Room Temperature) .

Item	Unit	Conditions	Min.	Typ.	Max.	Note
Central Luminance ILED=50mA	cd/m2		320	400	-	1, 3
Viewing Angle	degree	Horizontal (Right) CR = 10 (Left)	70 70	80 80	- -	1, 2
		Vertical (Upper) CR = 10 (Lower)	60 60	70 70	- -	
Luminance Uniformity	[%]	9 Point	62	70	-	1, 4
Contrast Ratio			500	700	-	1, 5
Cross talk			-	-	4	1, 6
Response Time	msec	Rising + Falling	-	8	16	1, 7
Color/ Chromaticity Coordinates	Red	Rx	0.588	0.638	0.688	1, 8
		Ry	0.293	0.343	0.393	
	Green	Gx	0.276	0.326	0.376	
		Gy	0.576	0.626	0.676	
	Blue	Bx	0.106	0.156	0.206	
		By	0.003	0.053	0.103	
	White	Wx	0.263	0.313	0.363	
		Wy	0.279	0.329	0.379	
NTSC	%		-	72	-	

## Note 1: Measurement method

The LCD module should be stabilized at given temperature for 30 minutes to avoid abrupt temperature change during measuring (at surface 35 °C). In order to stabilize the luminance, the measurement should be executed after lighting Backlight for 30 minutes in a stable, windless and dark room, and it should be measured in the center of screen.

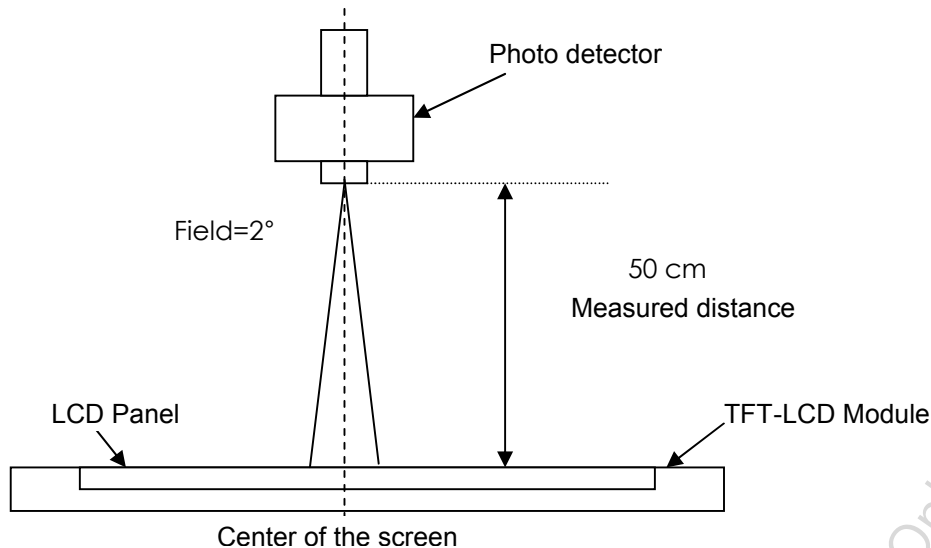

## Note 2: Definition of viewing angle measured by ELDIM (EZContrast 88)

Viewing angle is the measurement of contrast ratio  $\geq 10$  and  $\geq 5$ , at the screen center, over a 180° horizontal and 180° vertical range (off-normal viewing angles). The 180° viewing angle range is broken down as follows; 90° ( $\theta$ ) horizontal left and right and 90° ( $\Phi$ ) vertical, high (up) and low (down). The measurement direction is typically perpendicular to the display surface with the screen rotated about its center to develop the desired measurement viewing angle.

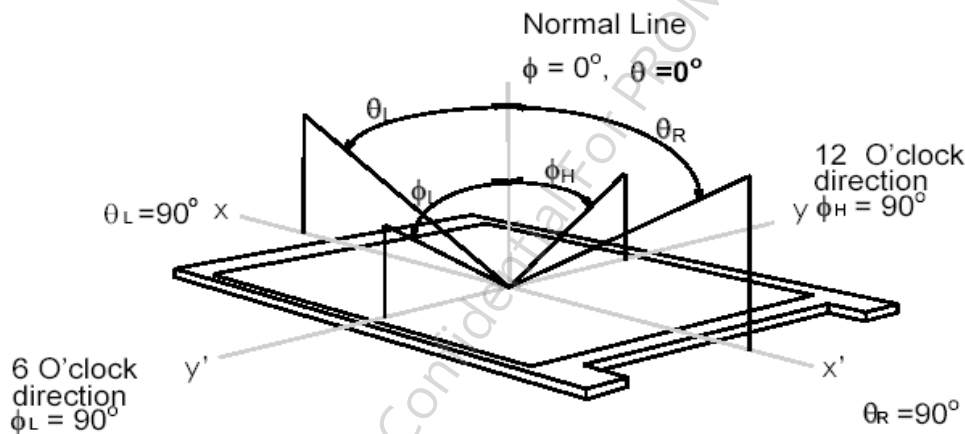

**Note 3: Central luminance** is measured by TOPCON SR-3.

**Note 4: Luminance uniformity** of these 9 points is defined as below and measured by TOPCON SR-3.

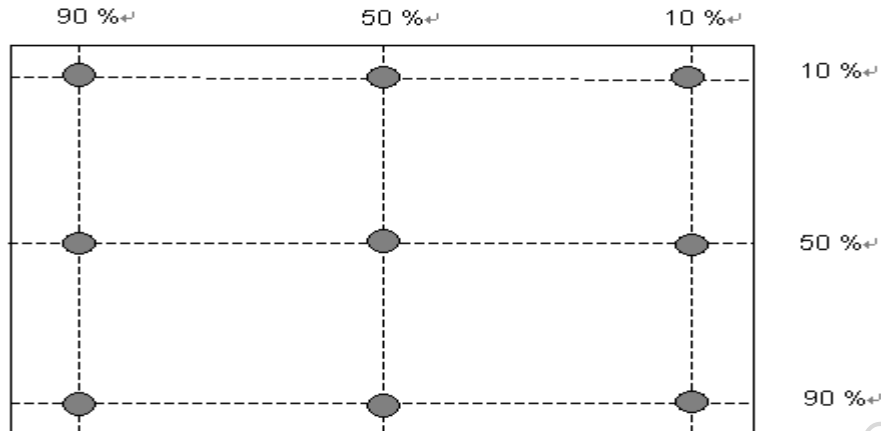

$$\text{Uniformity} = \frac{\text{Minimum Luminance in 9 points (1-9)}}{\text{Maximum Luminance in 9 Points (1-9)}}$$

**Note 5 : Contrast ratio** is measured by TOPCON SR-3

Contrast ratio is calculated with the following formula.

$$\text{Contrast ratio (CR)} = \frac{\text{Brightness on the "White" state}}{\text{Brightness on the "Black" state}}$$

**Note 6 :** Definition of **Cross Talk (CT)**

$$\text{CT} = | \text{YB} - \text{YA} | / \text{YA} \times 100 (\%)$$

Where

YA = Luminance of measured location without gray level 0 pattern (cd/m<sup>2</sup>)

YB = Luminance of measured location with gray level 0 pattern (cd/m<sup>2</sup>)

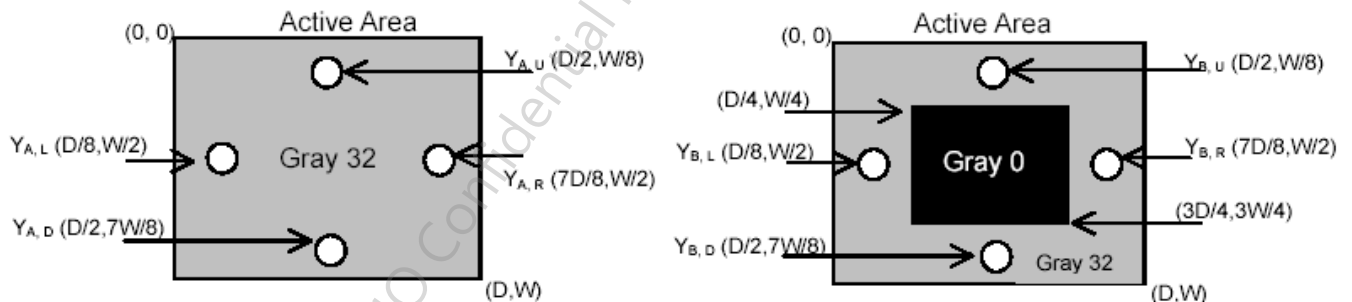



**Note 7: Definition of Response Time:**

The output signals of BM-7 or equivalent are measured when the input signals are changed from "Black" to "White" (falling time) and from "White" to "Black" (rising time), respectively. The response time interval between the 10% and 90% of amplitudes. Refer to figure as below.

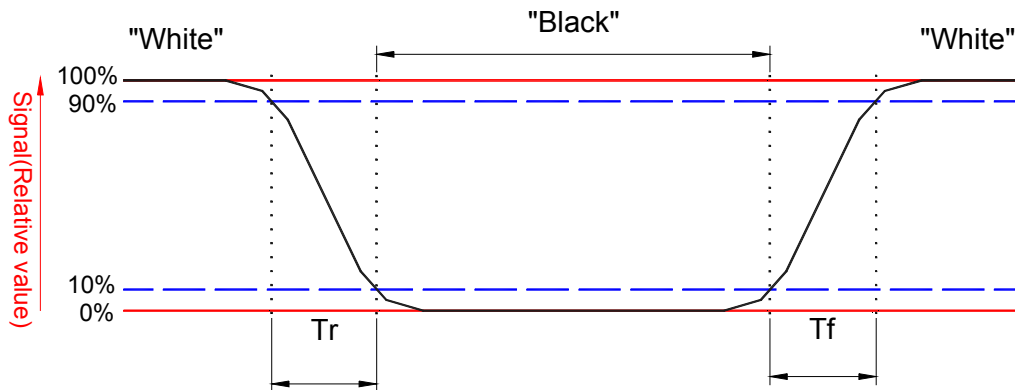

**Note 8: Color chromaticity and coordinates (CIE)** is measured by TOPCON SR-3.

### 3. Functional Block Diagram

The following diagram shows the functional block of the 15.6 inch Color TFT-LCD Module:

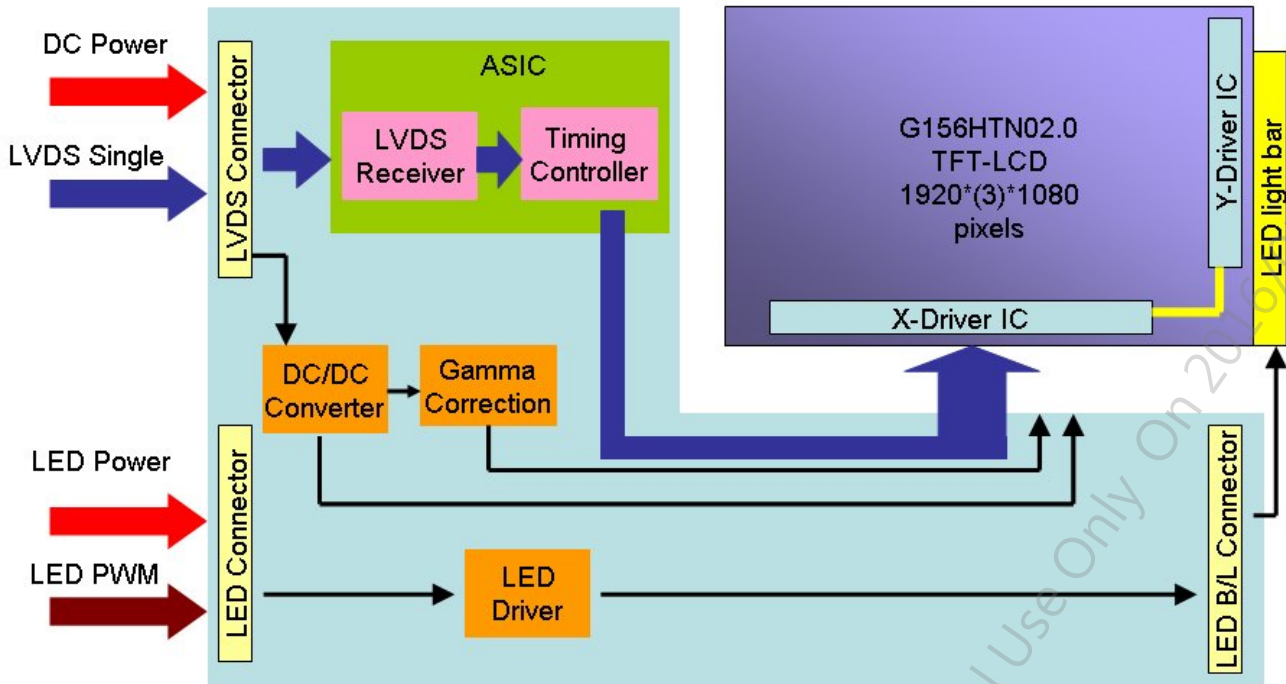



#### 4. Absolute Maximum Ratings

An absolute maximum rating of the module is as following:

##### 4.1 Absolute Ratings of TFT LCD Module

Item	Symbol	Min	Max	Unit	Conditions
Logic/LCD Drive	Vin	-0.3	+5.0	[Volt]	Note 1,2

##### 4.2 Absolute Ratings of Environment

Item	Symbol	Min	Max	Unit	Conditions
Operating Temp.	TOP	-10	+70	[°C]	Note 4
Operation Humidity	HOP	8	95	[%RH]	Note 4
Storage Temperature	TST	-20	+70	[°C]	Note 4
Storage Humidity	HST	5	95	[%RH]	Note 4

**Note 1:** At Ta (25°C)

**Note 2:** Permanent damage to the device may occur if exceed maximum values

**Note 3:** LED specification refer to section 5.2

**Note 4:** For quality performance, please refer to AUO IIS (Incoming Inspection Standard)

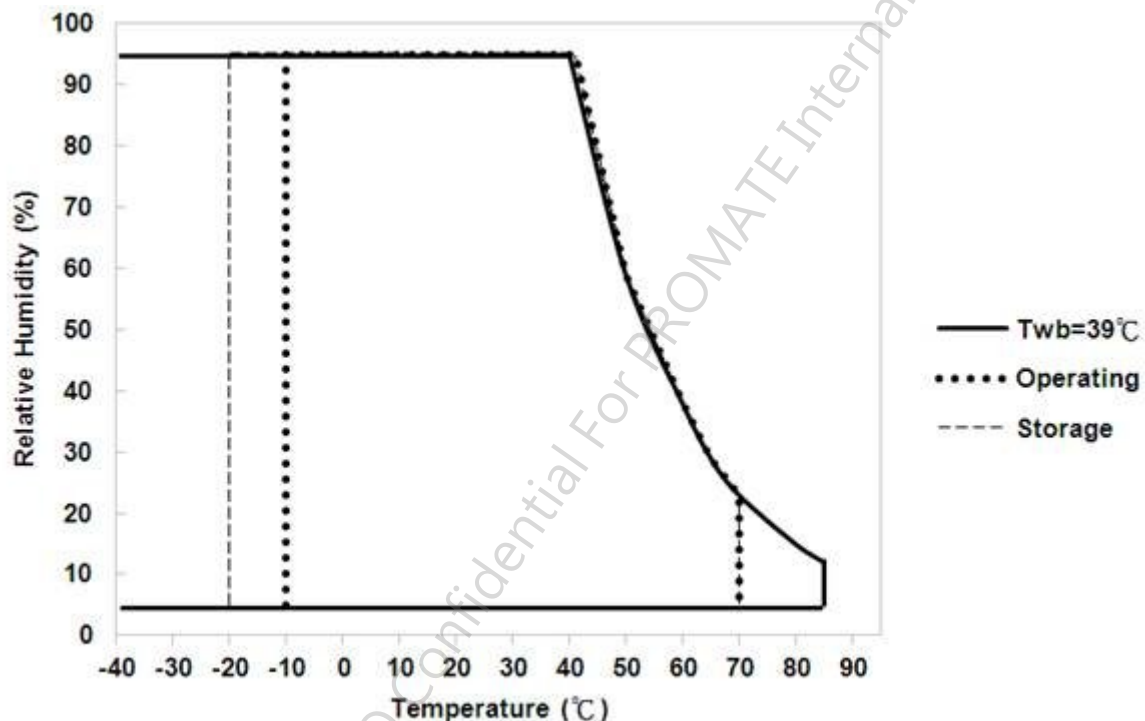

## 5. Electrical Characteristics

### 5.1 TFT LCD Module

#### 5.1.1 Power Specification

Input power specifications are as follows;

The power specification are measured under 25°C and frame frequency under 60Hz

Symble	Parameter	Min	Typ	Max	Units	Note
VDD	Logic/LCD Drive Voltage	3.0	3.3	3.6	[Volt]	
PDD	VDD Power	-	2.8	3.37	[Watt]	Note 1
IDD	IDD Current	-	850	1020	[mA]	Note 1
IRush	Inrush Current	-	-	2500	[mA]	Note 2
VDDrp	Allowable Logic/LCD Drive Ripple Voltage	-	-	200	[mV] p-p	

**Note 1:** Maximum Measurement Condition : Red Pattern

**Note 2:** Measure Condition

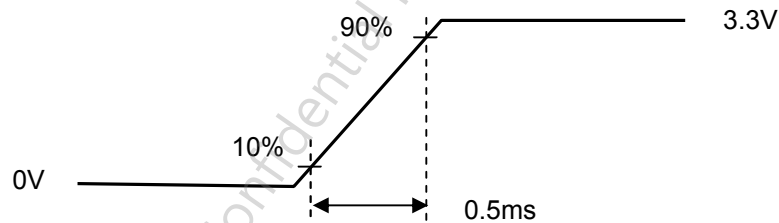
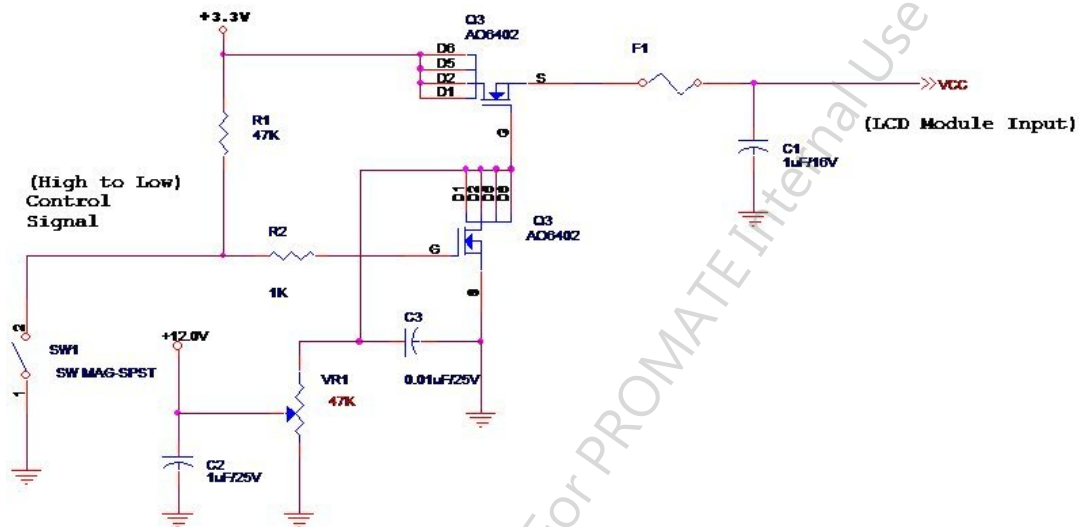

Vin rising time

## 5.1.2 Signal Electrical Characteristics

Input signals shall be low or High-impedance state when VDD is off.  
Signal electrical characteristics are as follows;

Symbol	Parameter	Min	Typ	Max	Units	Condition
$V_{TH}$	Differential Input High Threshold	-	-	+100	[mV]	$V_{CM} = 1.2V$ Note 1
$V_{TL}$	Differential Input Low Threshold	-100	-	-	[mV]	$V_{CM} = 1.2V$ Note 1
$ V_{ID} $	Input Differential Voltage	100	400	600	[mV]	Note 1
$V_{CM}$	Differential Input Common Mode Voltage	1.125	-	1.375	[Volt]	$V_{TH}-V_{TL} = 200mV$ (max)

**Note 1:** LVDS Signal Waveform

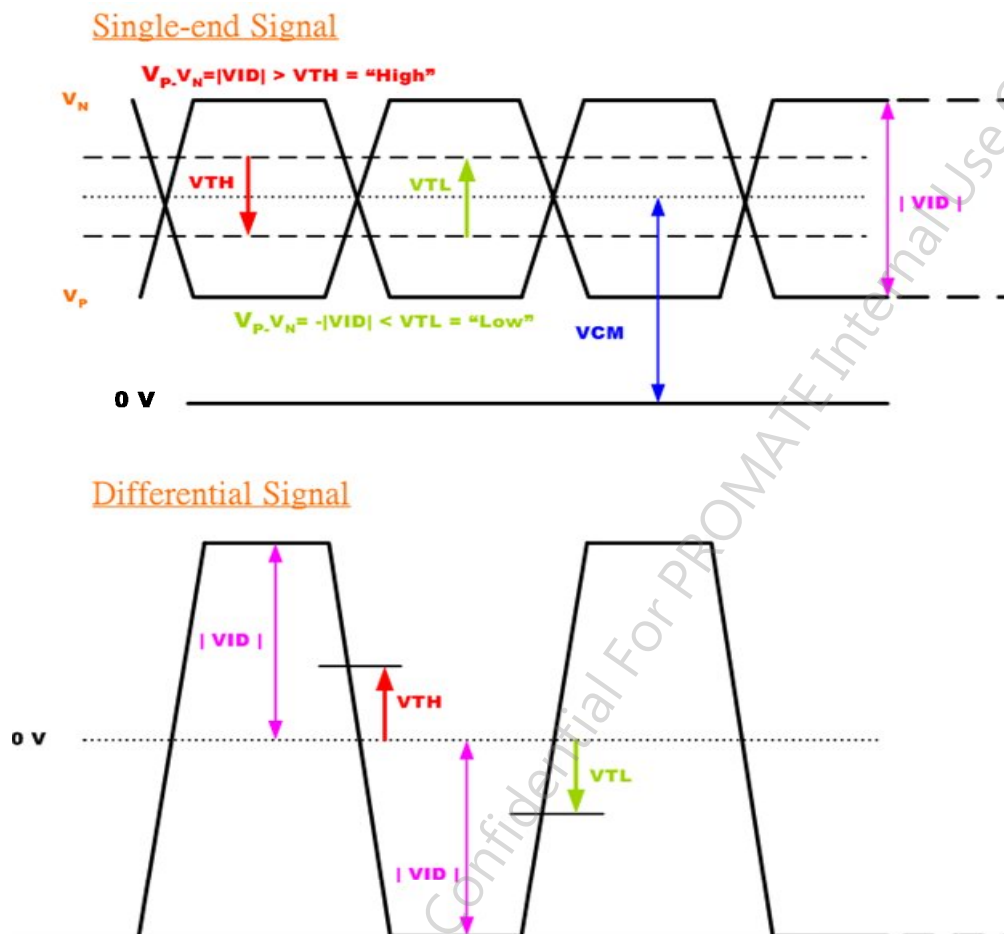



## 5.2 Backlight Unit

### 5.2.1 LED characteristics

Parameter	Symbol	Min	Typ	Max	Units	Condition
Backlight Power Consumption	PLED	-	-	10.5	[Watt]	(Ta=25°C), Note 1
LED Life-Time	N/A	30,000	50,000	-	Hour	(Ta=25°C), Note 2

**Note 1:** Calculator value for reference  $P_{LED} = V_F$  (Normal Distribution) \*  $I_F$  (Normal Distribution) / Efficiency  
**Note 2:** LED lifetime is definition: brightness is decreased to 50% of the initial value. The minimum life time of LED unit is on the condition of  $I_{R_{LED}} = 50mA$  and  $25\pm 2^\circ C$  (Room temperature).

### 5.2.2 Backlight input signal characteristics

Parameter	Symbol	Min	Typ	Max	Units	Remark
LED Power Supply	VLED	10.8	12.0	13.2	[Volt]	Define as Connector Interface (Ta=25°C)
LED Input Current	ILED		0.73	0.88	[A]	
LED Enable Input High Level	VLED_EN	2.5	-	5	[Volt]	
LED Enable Input Low Level		-	-	0.8	[Volt]	
PWM Logic Input High Level	VPWM_EN	2.5	-	5	[Volt]	
PWM Logic Input Low Level		-	-	0.8	[Volt]	
PWM Input Frequency	FPWM	200	-	15K	Hz	
PWM Duty Ratio	Duty	5	-	100	%	
LED Inrush Current	ILED <sub>Rush</sub>	-	-	2	[A]	

**Note 1:** Ta means ambient temperature of TFT-LCD module.

**Note 2:** VLED, ILED, PLED are defined for LED backlight. (100% duty of PWM)

**Note 3:** If module is driven by high current or at high ambient temperature & humidity condition. The operating life will be reduced.

**Note 4:** Operating life means brightness goes down to 50% initial brightness. Minimum operating life time is estimated data.

## 6. Signal Interface Characteristic

### 6.1 Pixel Format Image

Following figure shows the relationship of the input signals and LCD pixel format.

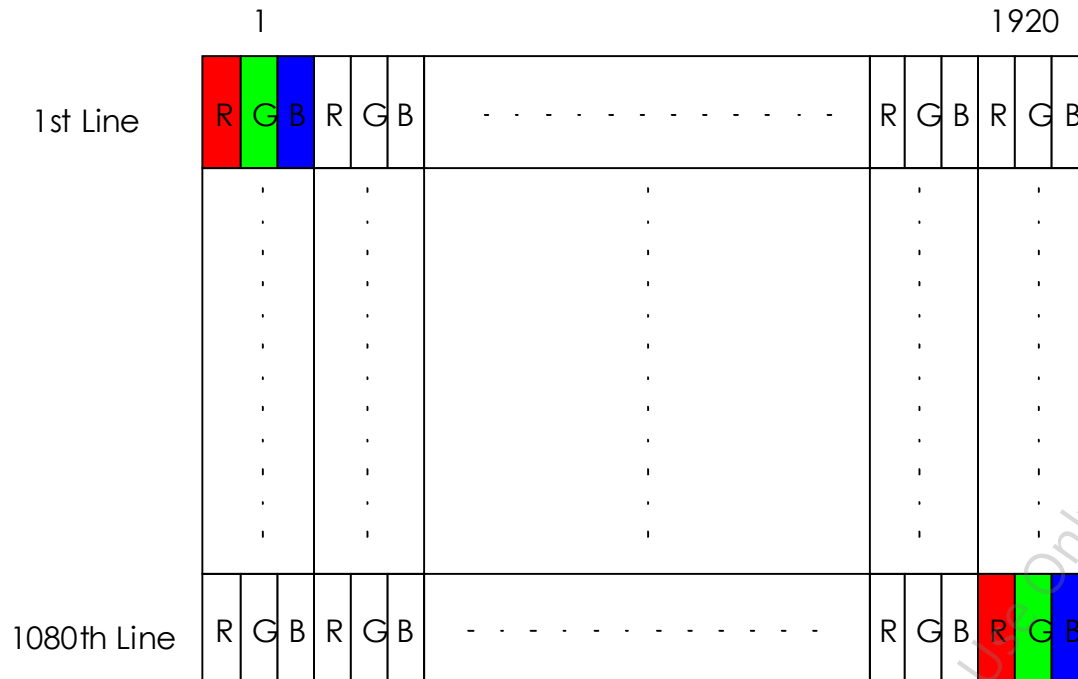

## 6.2 The Input Data Format

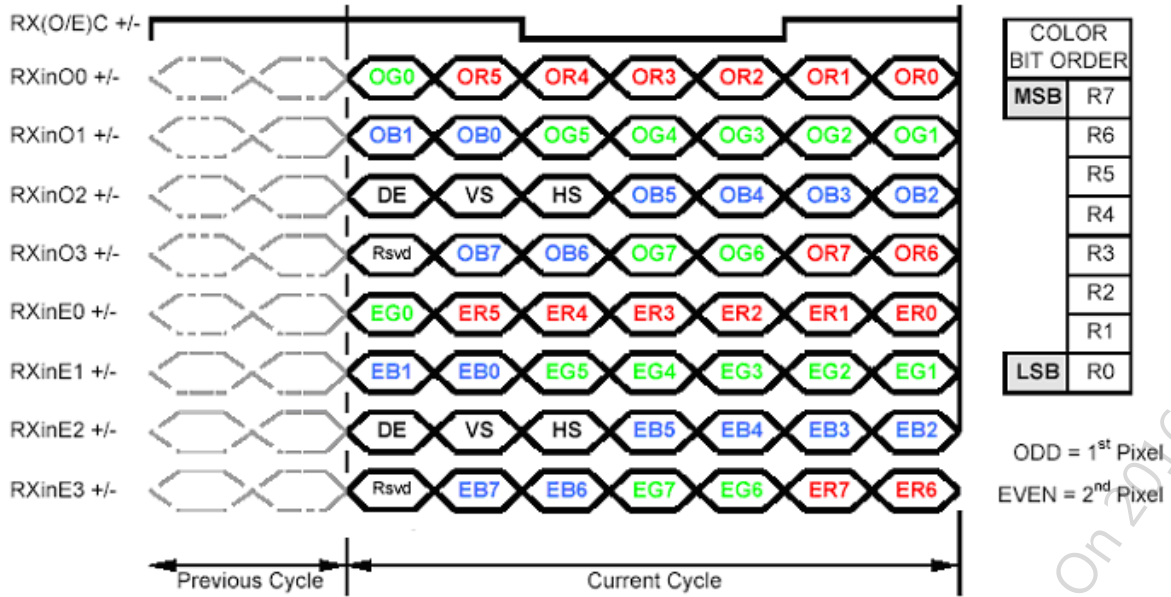





# Product Specification

AU OPTRONICS CORPORATION

## 6.3 Signal Description

The module using one LVDS receiver SN75LVDS82(Texas Instruments). LVDS is a differential signal technology for LCD interface and high speed data transfer device. LVDS transmitters shall be SN75LVDS83 (negative edge sampling). The first LVDS port (RxOxxx) transmits odd pixels while the second LVDS port(RxExxx) transmits even pixels.

Pin	Signal	Description
1	REIN3+	+ LVDS differential data input (Even CH3)
2	REIN3-	- LVDS differential data input (Even CH3)
3	RECLKIN+	+ LVDS differential data input (Even CLK)
4	RECLKIN-	- LVDS differential data input (Even CLK)
5	REIN2+	+ LVDS differential data input (Even CH2)
6	REIN2-	- LVDS differential data input (Even CH2)
7	GND	Ground
8	REIN1+	+ LVDS differential data input (Even CH1)
9	REIN1-	- LVDS differential data input (Even CH1)
10	GND	Ground
11	REIN0+	+ LVDS differential data input (Even CH0)
12	REIN0-	- LVDS differential data input (Even CH0)
13	ROIN3+	+ LVDS differential data input (Odd CH3)
14	ROIN3-	- LVDS differential data input (Odd CH3)
15	ROCLKIN+	+ LVDS differential data input (Odd CLK)
16	ROCLKIN-	- LVDS differential data input (Odd CLK)
17	GND	Ground
18	ROIN2+	+ LVDS differential data input (Odd CH2)
19	ROIN2-	- LVDS differential data input (Odd CH2)
20	ROIN1+	+ LVDS differential data input (Odd CH1)
21	ROIN1-	- LVDS differential data input (Odd CH1)
22	ROIN0+	+ LVDS differential data input (Odd CH0)
23	ROIN0-	- LVDS differential data input (Odd CH0)
24	GND	Ground
25	GND	Ground
26	GND	Ground
27	GND	Ground
28	VDD	+3.3V
29	VDD	+3.3V
30	VDD	+3.3V

## 6.4 Interface Timing (LVDS)

### 6.4.1 Timing Characteristics

Basically, interface timings should match the 1920x1080/ 60Hz manufacturing guide line timing.

Parameter		Symbol	Min.	Typ.	Max.	Unit
Frame Rate		-	40	60	60	Hz
Clock frequency		$1/T_{\text{Clock}}$	50	70.93	75	MHz
Horizontal Section	Period	$T_H$	1050	1065	1075	$T_{\text{clock}}$
	Active	$T_{HD}$	960			
	Blanking	$T_{HB}$	90	105	115	
Vertical Section	Period	$T_V$	1090	1110	1130	$T_{\text{line}}$
	Active	$T_{VD}$	1080			
	Blanking	$T_{VB}$	10	30	50	

**Note 1:** DE mode only.

### 6.4.2 Timing Diagram

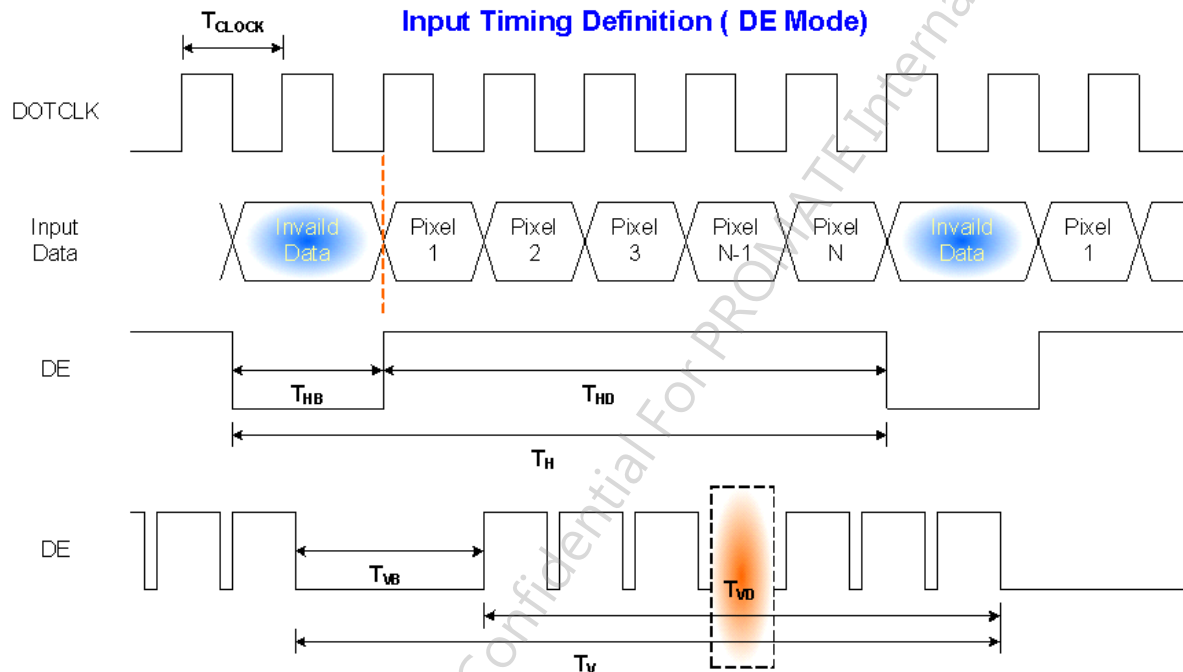

## 6.5 Power ON/OFF Sequence

LED on/off sequence is as follows. Interface signals are also shown in the chart.

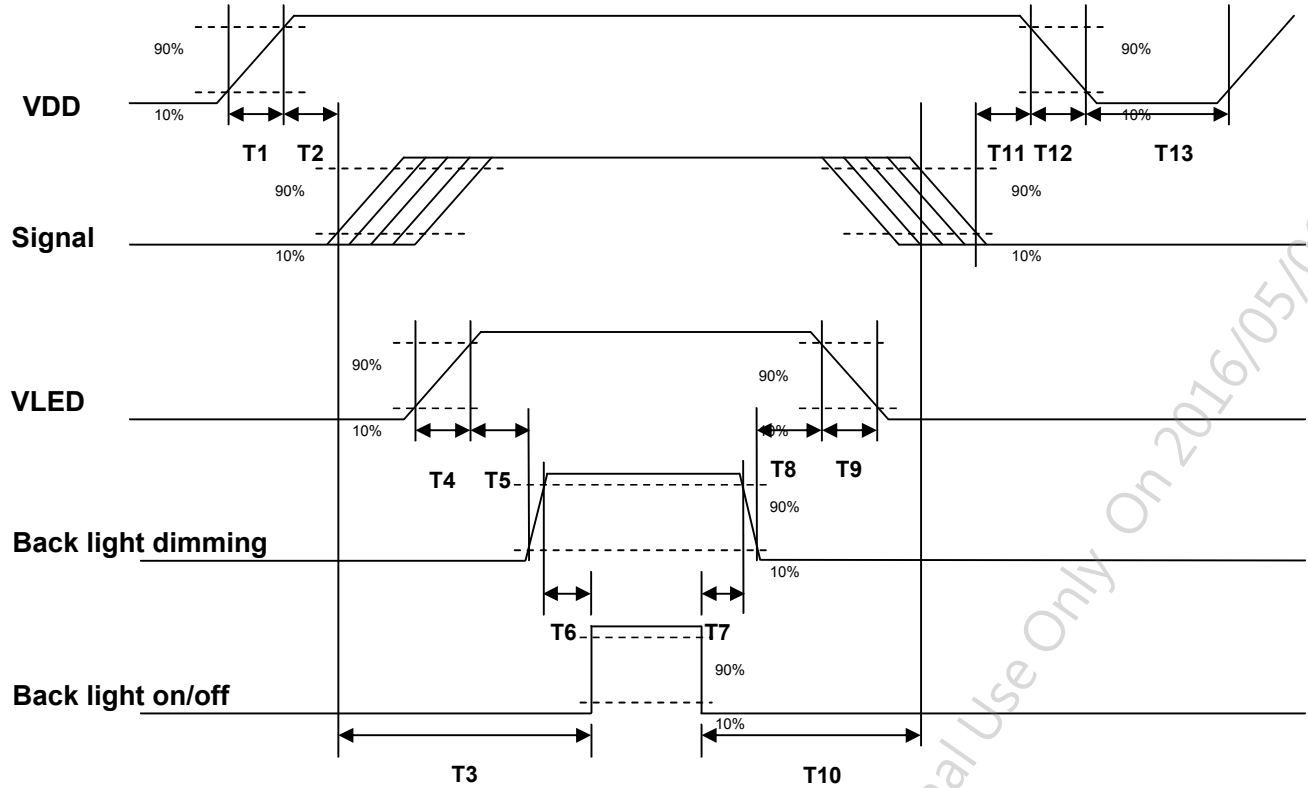

Parameter	Value			Units
	Min.	Typ.	Max.	
T1	0.5	-	10	[ms]
T2	60	-	70	[ms]
T3	400	-	-	[ms]
T4	0.5	-	10	[ms]
T5	10	-	-	[ms]
T6	10	-	180	[ms]
T7	10	-	180	[ms]
T8	10	-	-	[ms]
T9	-	-	10	[ms]
T10	110	-	-	[ms]
T11	0.5	16	50	[ms]
T12	-	-	10	[ms]
T13	1000	-	-	[ms]



## 7. Connector & Pin Assignment

Physical interface is described as for the connector on module. These connectors are capable of accommodating the following signals and will be following components.

### 7.1 TFT LCD Module

Connector Name / Designation	Interface Connector / Interface card
Manufacturer	HRS
Type Part Number	DF14H-30P-1.25H
Mating Housing Part Number	DF14H-30S-1.25C

#### 7.1.1 Pin Assignment

Pin#	Signal Name	Pin#	Signal Name
1	REIN3+	2	REIN3-
3	RECLKIN+	4	RECLKIN-
5	REIN2+	6	REIN2-
7	GND	8	REIN1+
9	REIN1-	10	GND
11	REIN0+	12	REIN0-
13	ROIN3+	14	ROIN3-
15	ROCLKIN+	16	ROCLKIN-
17	GND	18	ROIN2+
19	ROIN2-	20	ROIN1+
21	ROIN1-	22	ROIN0+
23	ROIN0-	24	GND
25	GND	26	GND
27	GND	28	VDD
29	VDD	30	VDD

### 7.2 Backlight Unit

Physical interface is described as for the connector on module. These connectors are capable of accommodating the following signals and will be following components.

Connector Name / Designation	LED Connector
Manufacturer	E&T
Type Part Number	3710K-Q10N-01R
Mating Housing Part Number	H113K-D10N-01B

## 7.2.1 LED Driver Connector Pin Assignment

Pin#	Symbol	Signal Name
1	VCC	+12V
2	VCC	+12V
3	VCC	+12V
4	VCC	+12V
5	GND	Ground
6	GND	Ground
7	GND	Ground
8	GND	Ground
9	ENABLE	LED enable pin
10	PWM	System PWM Single Input

**Note1:** Start from right side

**Note2:** Connector Illustration

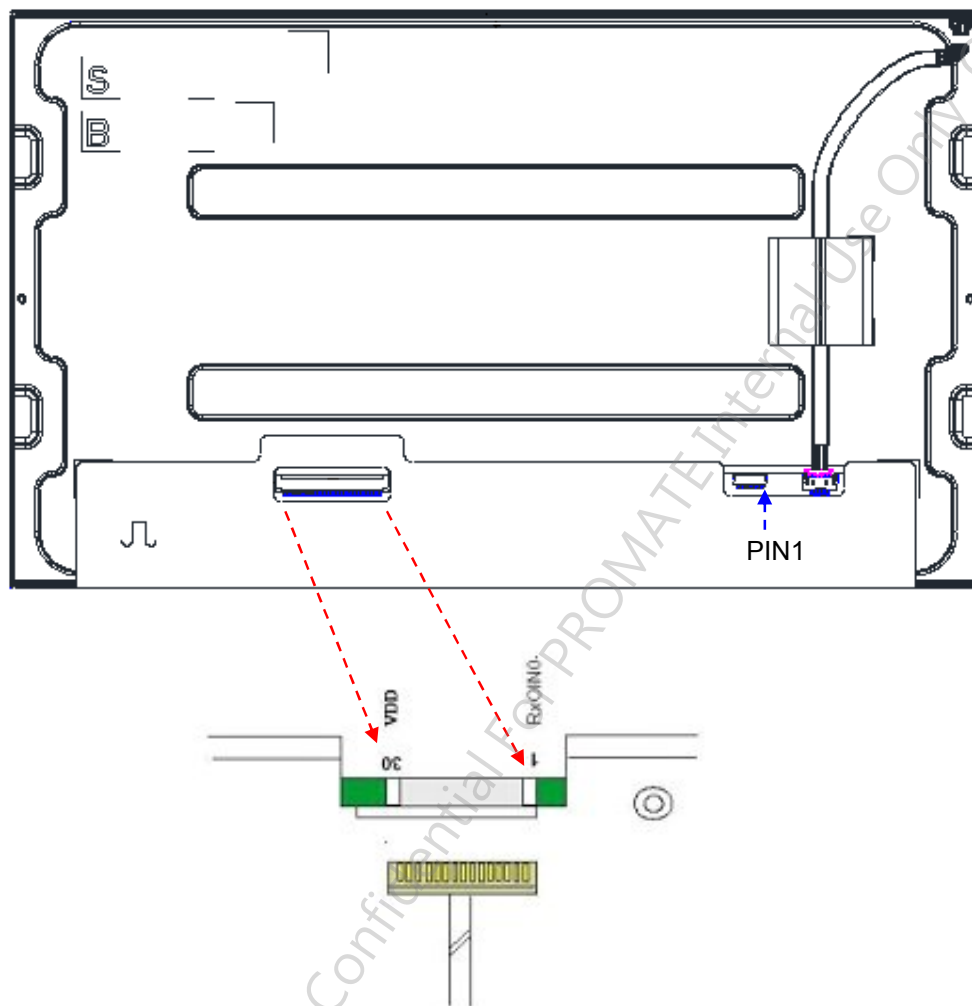



## 8. Panel Reliability Test

Environment test conditions are listed as following table.

Test items	Conditions	Note
High temperature and high humidity(THB)	Ta= 40°C, 90%RH, 300hrs	Note 1, 2
High Temperature Operation(HTO)	Ta= 70°C , Dry, 300hrs	
Low Temperature Operation(LTO)	Ta= -10°C, 300hrs	
High Temperature Storage(HTS)	Ta= 70°C, Dry, 300hrs	
Low Temperature Storage(LTS)	Ta= -20°C, 300hrs	
Thermal Shock Test(TST)	Ta=-20°C to 60°C, Duration at 30 min, 100 cycles	
Vibration Test (Non-operation)	Test method: Non-Operation Acceleration: 1.5 G Frequency:10 - 200 -10Hz Sweep: Sin wave vibration; 30 minutes each axis (X, Y, Z)	
Shock Test (Non-operation)	Test method: Non-Operation Acceleration: 50 G; Wave: Half-sin Active time: 20 ms Direction: ±X,±Y,±Z (one time for each axis)	
Electro Static discharge (ESD)	Contact Discharge: ±8 KV, Air Discharge: ±15 KV	Note 1

**Note 1:** According to EN 61000-4-2 , ESD class B: Some performance degradation allowed. Self-recoverable. No data lost, No hardware failures.

**Note 2:**

- Water condensation is not allowed for each test items.
- Each test is done by new TFT-LCD module. Don't use the same TFT-LCD module repeatedly for reliability test.
- The reliability test is performed only to examine the TFT-LCD module capability.
- To inspect TFT-LCD module after reliability test, please store it at room temperature and room humidity for 24 hours at least in advance.
- No function failure occurs. Mura shall be ignored after high temperature reliability test.

## 9. Shipping and Package

### 9.1 Shipping Label Format

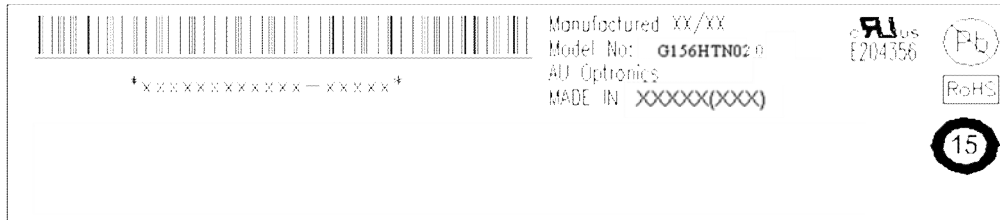

**Note 1:** For Pb Free products, AUO will add for identification.

**Note 2:** For RoHS compatible products, AUO will add for identification.

**Note 3:** For China RoHS compatible products, AUO will add for identification.

**Note 4:** The Green Mark will be presented only when the green documents have been ready by AUO Internal Green Team.

### 9.2 Carton Package

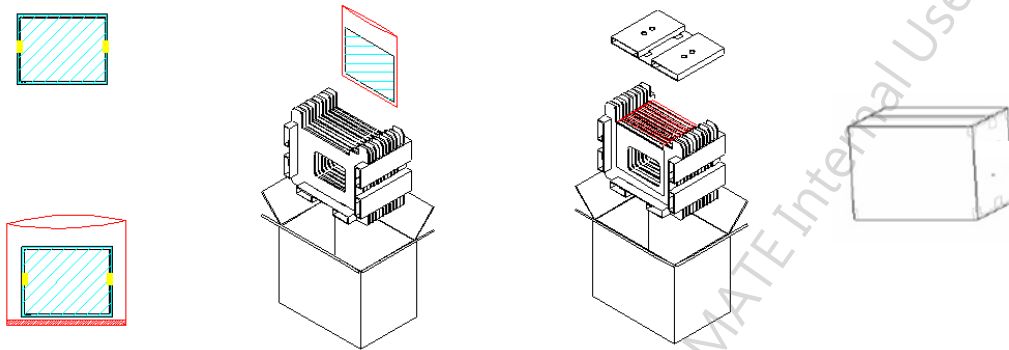

Max capacity : 16 TFT-LCD module per carton

Max weight: 16.3 kg per carton

Outside dimension of carton: 450mm(L)\*375mm(W)\*319mm(H)

Pallet size : 1150 mm \* 910 mm \* 132mm

#### Box stacked

Module by air : (2 \*3) \*4 layers , one pallet put 24 boxes , total 384pcs module

Module by sea : (2 \*3) \*4 layers+(2 \*3) \*1 layers , two pallet put 30 boxes , total 480pcs module

Module by sea\_HQ : (2 \*3) \*4 layers+(2 \*3) \*2 layers , two pallet put 42 boxes , total 576 pcs module

### 9.3 Shipping Package of Palletizing Sequence

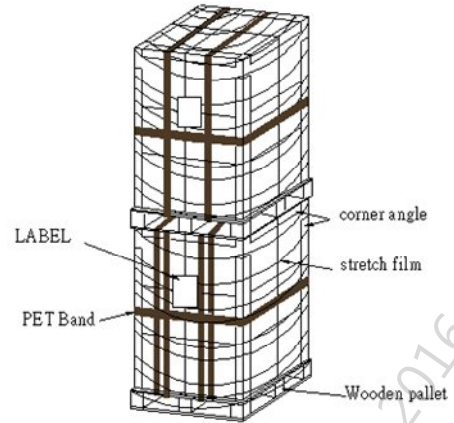
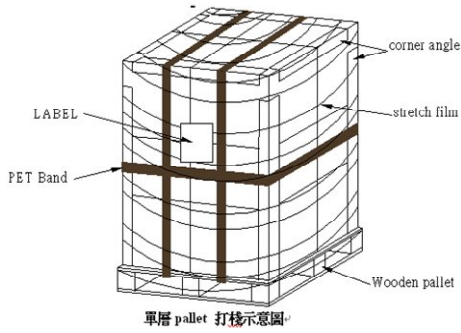

AUO Confidential For PROMATE Internal Use Only On 2016/05/06



## 10. Handling guide

This is a LCD model, and please be cautious when pulling it out of package or assembling it onto platform. Careless handlings, e.g. twist, bending, pressing, or collision, will result malfunction of LCD models.

### (1) Handling method notice



Do not lift and hold the panel with single hand at right or left side from tray.

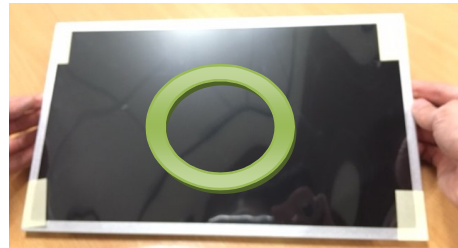

Lift and hold the panel up with both hands from tray.

### (2) On the table notice

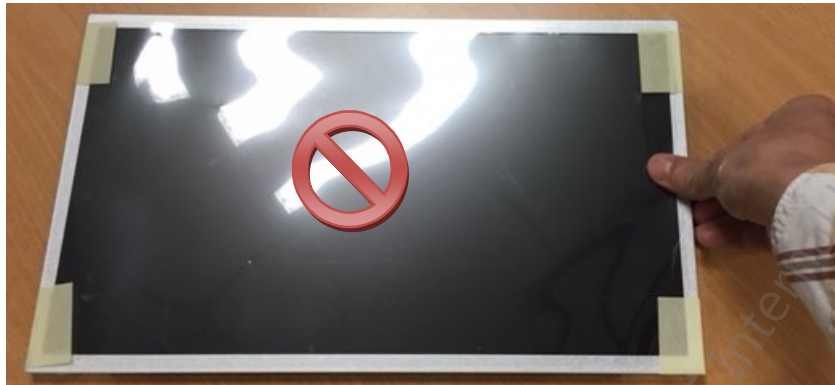

Do not press edge of panel to avoid glass broken.



Do not press the surface of the panel to avoid the glass broken or polarizer scratch.



Do not put anything or tool on the panel to avoid the glass broken or polarizer scratch.

### (3) Cable assembly notice



Do not insert the connector with single hand and touching the PCBA.

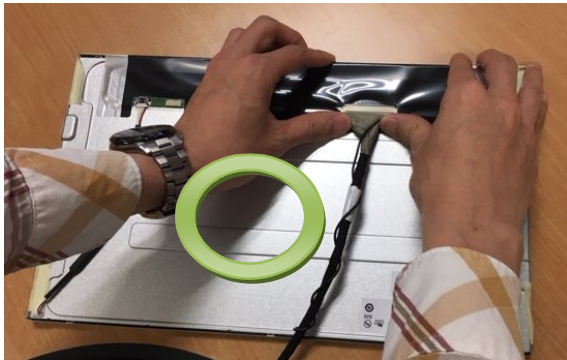

Insert the connector by pushing right and left edge.

AUO Confidential For PROMATE Internal Use Only On 2016/05/06



# Product Specification

AU OPTRONICS CORPORATION

## 11 .Mechanical Characteristics

### 11.1 LCM Outline Dimension (Front View)

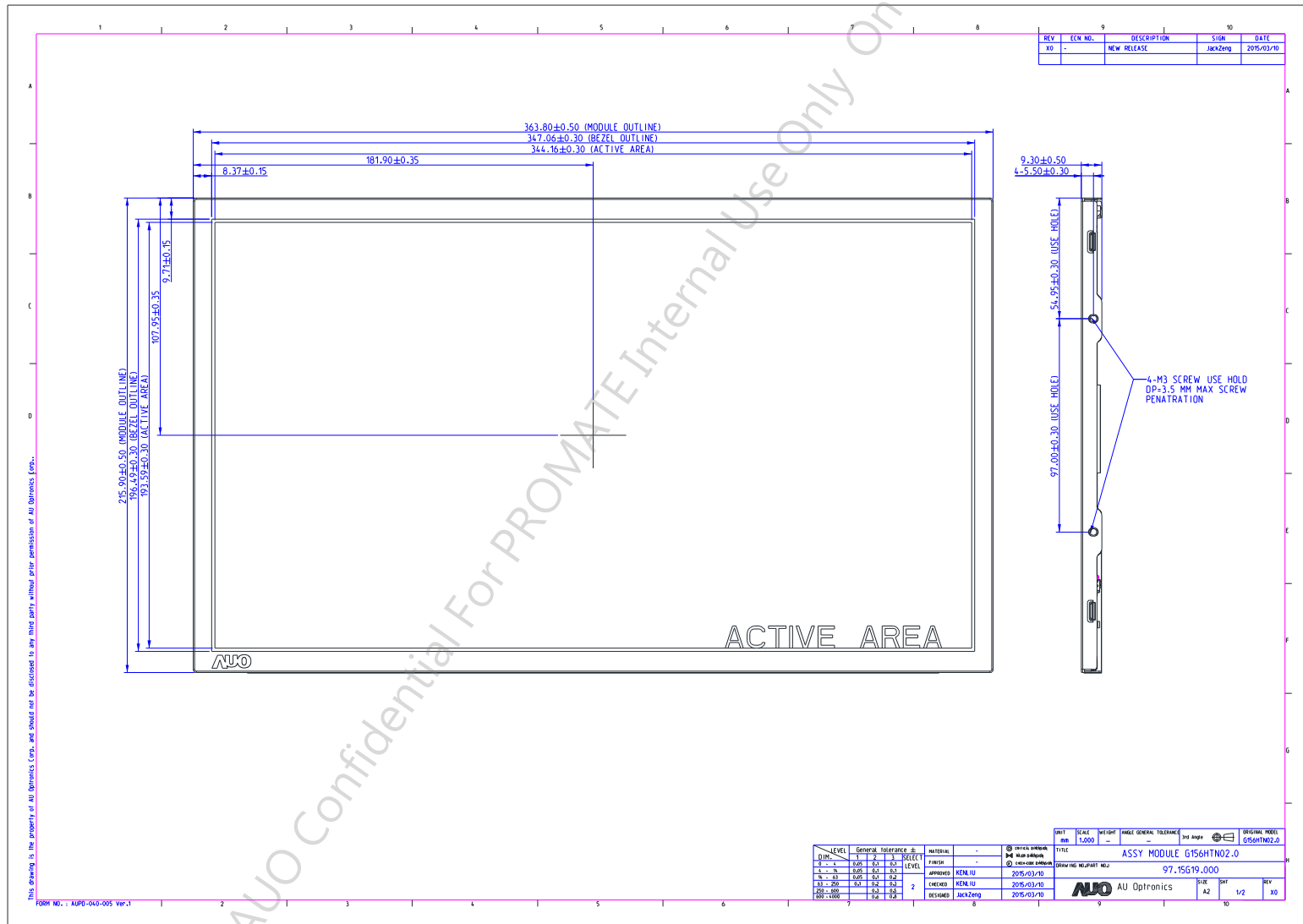



# Product Specification

AU OPTRONICS CORPORATION

## 11.2 LCM Outline Dimension (Rear View)

