

InfoVision Optoelectronics (Kunshan) Co.,LTD.

	Document Title	M123AWF4 R0 Product Specification			Page 1 of 31	
	Document No.	M123AWF4-R0	Issue Date	2022/8/31	Ver.	01

Customer Approved Specification

To:

Product Name:

Document Issue Date:

Customer	InfoVision Optoelectronics
<p style="text-align: center;"><u>SIGNATURE</u></p> <p style="text-align: center;">_____</p> <p style="text-align: center;">_____</p> <p style="text-align: center;">_____</p> <p>Please return 1 copy for your confirmation with your signature and comments.</p>	<p style="text-align: center;"><u>SIGNATURE</u></p> <p style="text-align: center;">QA</p> <p style="text-align: center;">_____</p> <p style="text-align: center;">PREPARED BY</p> <p style="text-align: center;">FAE</p> <p style="text-align: center;">_____</p>

- Note: 1. Please contact IforVision Company. before designing your product based on this product.
2. The information contained herein is presented merely to indicate the characteristics and performance of our products. No responsibility is assumed by IVO for any intellectual property claims or other problems that may result from application based on the module described herein.

FQ-7-30-0-009-03D

InfoVision Optoelectronics (Kunshan) Co.,LTD.

	Document Title	M123AWF4 R0 Product Specification			Page 3 of 31	
	Document No.	M123AWF4-R0	Issue Date	2022/8/31	Ver.	01

CONTENTS

1.0	GENERAL DESCRIPTIONS	4
2.0	ABSOLUTE MAXIMUM RATINGS	7
3.0	OPTICAL CHARACTERISTICS	6
4.0	ELECTRICAL CHARACTERISTICS	10
5.0	MECHANICAL CHARACTERISTICS	24
6.0	RELIABILITY CONDITIONS	25
7.0	PACKAGE SPECIFICATION	27
8.0	LOT MARK	28
9.0	GENERAL PRECAUTION	28

InfoVision Optoelectronics (Kunshan) Co.,LTD.

	Document Title	M123AWF4 R0 Product Specification			Page 4 of 31	
	Document No.	M123AWF4-R0	Issue Date	2022/8/31	Ver.	01

1.0 General Descriptions

1.1 Introduction

The M123AWF4 R0 is a Color Active Matrix Liquid Crystal Display with a back light system. The matrix uses a-Si Thin Film Transistor as a switching device. This TFT LCD has a 12.3 inch diagonally measured active display area with FHD resolution (1,920 horizontal by 720 vertical pixels array).

1.2 Features

- Supported FHD Resolution
- LVDS Interface
- Wide View Angle
- Compatible with RoHS Standard

1.3 Product Summary

Items	Specifications	Unit
Screen Diagonal	12.3	inch
Active Area (H x V)	292.032 x 109.512	mm
Number of Pixels (H x V)	1,920 x 720	-
Pixel Pitch (H x V)	0.1521 x 0.1521	mm
Pixel Arrangement	R.G.B. Vertical Stripe	-
Display Mode	Normally Black	-
White Luminance	940 (Typ.)	cd /m ²
Contrast Ratio	1000 (Typ.)	-
Response Time	30 (Max.)@25°C	ms
Input Voltage	3.3 (Typ.)	V
Power Consumption	14.48 (Max.) @ Mosaic,FV=60Hz	W
Weight	380(Max.)	g
Outline Dimension (H x V x D) With PCBA	299.032(Typ.) x 123.012(Typ.) x 8.023 (Max.)	mm
Electrical Interface (Logic)	LVDS	-
Support Color	16.7 M	-
NTSC	73%(Typ)	%
SCI	6(Typ)	%
Optimum Viewing Direction	All O'clock	-
Surface Treatment	HC/3H	-

	Document Title	M123AWF4 R0 Product Specification			Page 5 of 31	
	Document No.	M123AWF4-R0	Issue Date	2022/8/31	Ver.	01

1.4 Functional Block Diagram

Figure 1 shows the functional block diagram of the LCD module.

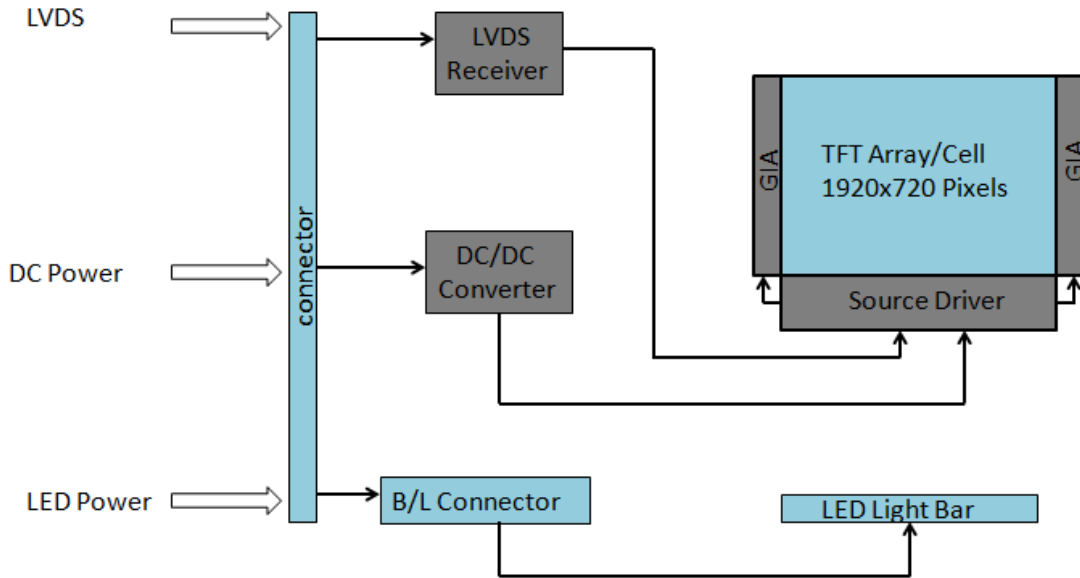

Figure 1 Block Diagram

1.5 Pixel Mapping

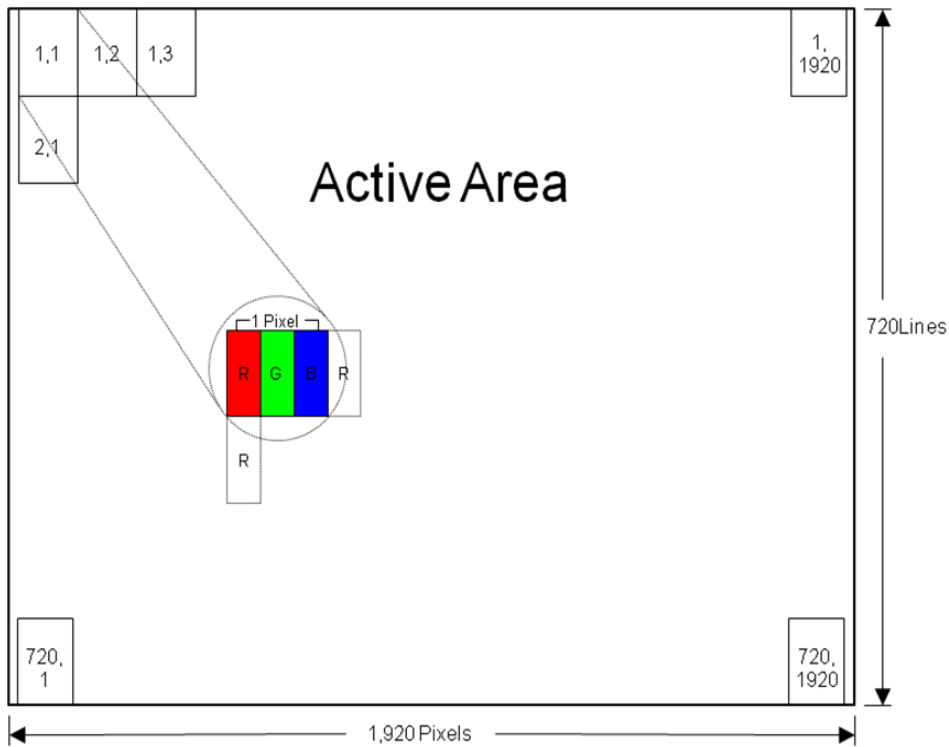

Figure 2 Pixel Mapping

2.0 Absolute Maximum Ratings

InfoVision Optoelectronics (Kunshan) Co.,LTD.

	Document Title	M123AWF4 R0 Product Specification			Page 6 of 31	
	Document No.	M123AWF4-R0	Issue Date	2022/8/31	Ver.	01

Table 1 Electrical & Environment Absolute Rating

Item	Symbol	Min.	Max.	Unit	Note
Logic Supply Voltage	V_{CC}	-0.3	4.0	V	(1),(2), (3),(4)
Logic Input Signal Voltage	V_{Signal}	-0.3	$V_{CC}+0.3$	V	
Operating Temperature	T_{gs}	-30	85	°C	
Storage Temperature	T_a	-40	90	°C	

Note (1) All the parameters specified in the table are absolute maximum rating values that may cause faulty operation or unrecoverable damage, if exceeded. It is recommended to follow the typical value.

Note (2) All the contents of electro-optical specifications and display fineness are guaranteed under Normal Conditions. All the display fineness should be inspected under normal conditions. Normal conditions are defined as follow: Temperature: 25°C, Humidity: 55± 10%RH.

Note (3) Unpredictable results may occur when it was used in extreme conditions. T_a = Ambient Temperature, T_{gs} = Glass Surface Temperature. All the display fineness should be inspected under normal conditions.

Note (4) Temperature and relative humidity range are shown in the figure below. Wet bulb temperature should be lower than 57.8°C, and no condensation of water. Besides, protect the module from static electricity.

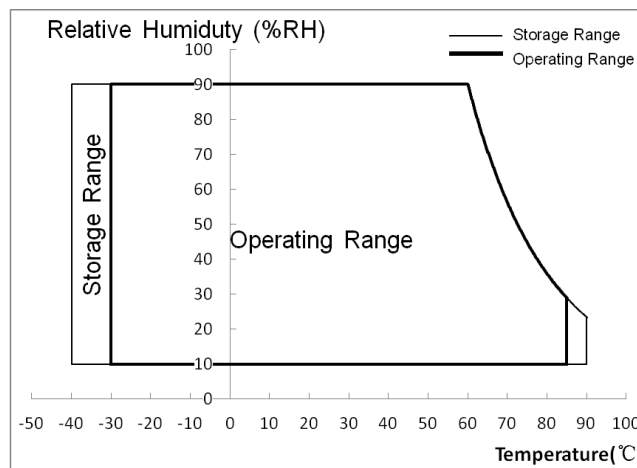



Figure 3 Absolute Ratings of Environment of the LCD Module

InfoVision Optoelectronics (Kunshan) Co.,LTD.

	Document Title	M123AWF4 R0 Product Specification			Page 7 of 31	
	Document No.	M123AWF4-R0	Issue Date	2022/8/31	Ver.	01

3.0 Optical Characteristics

The optical characteristics are measured under stable conditions as following notes.

Table 2 Optical Characteristics

Item	Conditions	Min.	Typ.	Max.	Unit	Note
Viewing Angle (CR>10)	Horizontal	θ_{x+}	80	85	-	degree (1),(2),(3),(4)(8)
		θ_{x-}	80	85	-	
	Vertical	θ_{y+}	80	85	-	
		θ_{y-}	80	85	-	
Contrast Ratio	Center	800	1000	-	-	(1),(2),(4),(8) $\theta_x=\theta_y=0^\circ$
Response Time T=25℃	Rising + Falling	-	25	30	ms	(1),(2),(5),(8) $\theta_x=\theta_y=0^\circ$
Response Time T=-20℃		-	170	250	ms	
Response Time T=-30℃		-	360	450	ms	
Color Chromaticity (CIE1931)	Red x	Typ. -0.04	0.621	Typ. +0.04	-	(1),(2),(3),(8) $\theta_x=\theta_y=0^\circ$
	Red y		0.313		-	
	Green x		0.304		-	
	Green y		0.650		-	
	Blue x		0.157		-	
	Blue y		0.054		-	
	White x		0.300		-	
	White y		0.320		-	
NTSC	-	70	73	-	%	(1),(2),(3),(8) $\theta_x=\theta_y=0^\circ$
White Luminance	Center Point	800	940	-	cd/m ²	(1),(2),(6),(8) $\theta_x=\theta_y=0^\circ$
Luminance Uniformity	9 Points@white	70	80	-	%	(1),(2),(7),(8) $\theta_x=\theta_y=0^\circ$
	9 Points@black	50	60	-		

Note (1) Measurement Setup:

The LCD module should be stabilized at given ambient temperature (25℃) for 30 minutes to avoid abrupt temperature changing during measuring. In order to stabilize the luminance, the

InfoVision Optoelectronics (Kunshan) Co.,LTD.

	Document Title	M123AWF4 R0 Product Specification			Page 8 of 31	
	Document No.	M123AWF4-R0	Issue Date	2022/8/31	Ver.	01

measurement should be executed after lighting backlight for 30 minutes in the windless room.

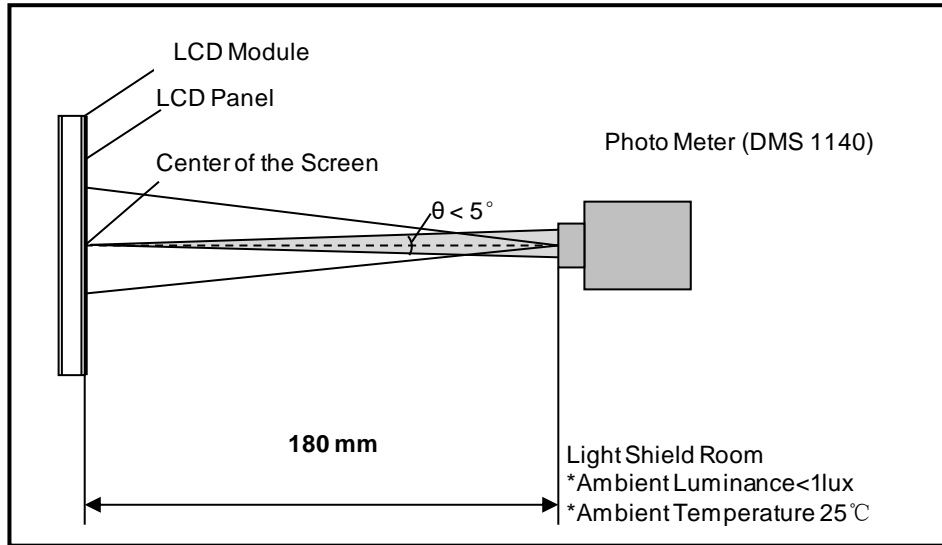

Figure 4 Measurement Setup

Note (2) The LED input parameter setting as:

$$I_{LED}: 360mA$$

Note (3) Definition of Viewing Angle

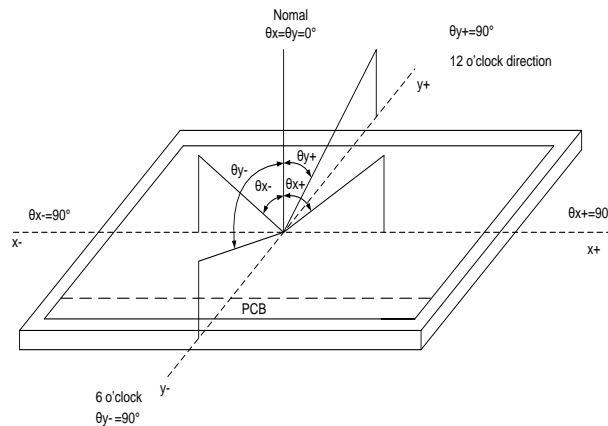

Figure 5 Definition of Viewing Angle

Note (4) Definition of Contrast Ratio (CR)

The contrast ratio can be calculated by the following expression:

Contrast Ratio (CR) = The luminance of White pattern / The luminance of Black pattern

Note (5) Definition of Response Time (T_R , T_F)

InfoVision Optoelectronics (Kunshan) Co.,LTD.

	Document Title	M123AWF4 R0 Product Specification			Page 9 of 31	
	Document No.	M123AWF4-R0	Issue Date	2022/8/31	Ver.	01

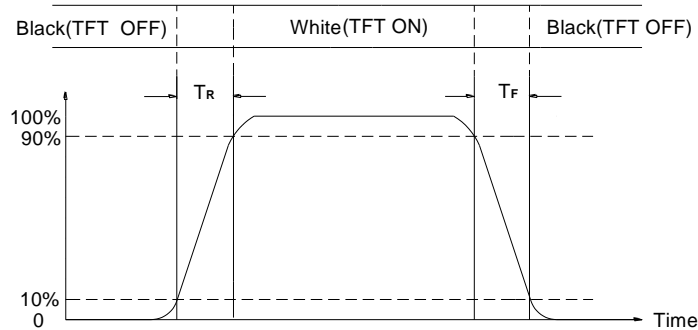

Figure 6 Definition of Response Time

Note (6) Definition of Luminance of White

Measure the luminance of White pattern (Ref.: Active Area)

Display Luminance=L1 (center point)

H—Active Area Width, V—Active Area Height, L—Luminance

Note (7) Definition of Luminance Uniformity (Ref.: Active Area)

Measure the luminance of White pattern at X points.

Luminance Uniformity= $\text{Min.}(L1, L2, \dots L9) / \text{Max.}(L1, L2, \dots L9)$

H—Active Area Width, V—Active Area Height, L—Luminance

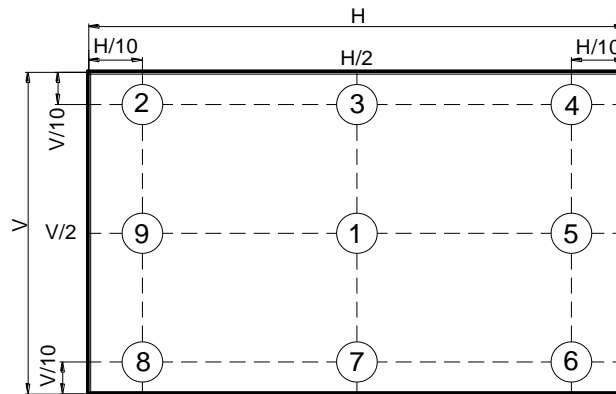



Figure 7 Measurement Locations of 9 Points

Note (8) All optical data are based on IVO given system & nominal parameter & testing machine in this document.

InfoVision Optoelectronics (Kunshan) Co.,LTD.

	Document Title	M123AWF4 R0 Product Specification			Page 10 of 31	
	Document No.	M123AWF4-R0	Issue Date	2022/8/31	Ver.	01

4.0 Electrical Characteristics

4.1 Interface Connector

Table 3 Signal Connector Type

Item	Description
Manufacturer / Type	BJD-101049-205050

Table 4 Signal Connector Pin Assignment

Pin No.	Symbol	Description	Remarks
1	GND	Digital ground	-
2	BIST	LCD Panel Self Test Enable, When it is not used, connecting to GND is recommended, don't floating	Active as3.3V
3	VCC	Digital Power/Vin =3.3V	-
4	VCC	Digital Power/Vin =3.3V	-
5	GND	Power ground	-
6	GND	Power ground	-
7	OTP	Serial interface OTP power	(1) 8.6V
8	NC	No connection	-
9	GND	Power ground	-
10	ORXIN0-	Negative LVDS differential data input(Odd data)	-
11	ORXIN0+	Positive LVDS differential data input(Odd data)	-
12	ORXIN1-	Negative LVDS differential data input(Odd data)	-
13	ORXIN1+	Positive LVDS differential data input(Odd data)	-
14	ORXIN2-	Negative LVDS differential data input(Odd data)	-
15	ORXIN2+	Positive LVDS differential data input(Odd data)	-
16	ORXCLKIN-	Negative LVDS differential data input(Odd clock)	-
17	ORXCLKIN+	Positive LVDS differential data input(Odd clock)	-
18	ORXIN3-	Negative LVDS differential data input(Odd data)	-

InfoVision Optoelectronics (Kunshan) Co.,LTD.

	Document Title	M123AWF4 R0 Product Specification			Page 11 of 31	
	Document No.	M123AWF4-R0	Issue Date	2022/8/31	Ver.	01

19	ORXIN3+	Positive LVDS differential data input(Odd data)	-
20	ERXIN0-	Negative LVDS differential data input(Even data)	-
21	ERXIN0+	Positive LVDS differential data input(Even data)	-
22	ERXIN1-	Negative LVDS differential data input(Even data)	-
23	ERXIN1+	Positive LVDS differential data input(Even data)	-
24	ERXIN2-	Negative LVDS differential data input(Even data)	-
25	ERXIN2+	Positive LVDS differential data input(Even data)	-
26	ERXCLKIN-	Negative LVDS differential data input(Even clock)	-
27	ERXCLKIN+	Positive LVDS differential data input(Even clock)	-
28	ERXIN3-	Negative LVDS differential data input(Even data)	-
29	ERXIN3+	Positive LVDS differential data input(Even data)	-
30	GND	Power ground	-
31	FAULT	FAULT signal output(normal=H,abnormal=L)	-
32	RESET	Global reset pin. Active low, if RESET connected to GND, the chip is in reset state. This pin must meet the sequence of power on/off.	-
33	STBYB	Standby mode setting pin. STBYB=H, normal operation. STBYB=L, timing controller, output buffer, DAC and power circuit all off. This pin must meet the sequence of power on/off.	-
34	CSB	Serial interface chip enable	(1)
35	SCL	Serial interface clock input	
36	SDAI	Serial interface data input	
37	SDAO	Serial interface data output.	
38	GND	Power ground	-
39	GND	Power ground	-
40	NC	No connection	-

InfoVision Optoelectronics (Kunshan) Co.,LTD.

	Document Title	M123AWF4 R0 Product Specification			Page 12 of 31	
	Document No.	M123AWF4-R0	Issue Date	2022/8/31	Ver.	01

41	LEDA	LED power(Anode)	36.3V
42	LEDA	LED power(Anode)	
43	LEDA	LED power(Anode)	
44	NC	No connection	-
45	LEDK	Cathode1	90mA
46	LEDK	Cathode2	90mA
47	LEDK	Cathode3	90mA
48	LEDK	Cathode4	90mA
49	NTC_A	NTC_Anode	-
50	NTC_K	NTC_Cathode	-

Note(1): Pin 7,34-37 only for IVO use, NC is recommended.

4.2 Signal Electrical Characteristics

4.2.1 Signal Electrical Characteristics For LVDS Receiver

The built-in LVDS receiver is compatible with (ANSI/TIA/TIA-644) standard.

Table 5 LVDS Receiver Electrical Characteristics

Parameter	Symbol	Min.	Typ.	Max.	Unit	Conditions
Differential Input High Threshold	V _{th}	+150	-	-	mV	V _{CM} =+1.2V
Differential Input Low Threshold	V _{tl}	-	-	-150	mV	-
Magnitude Differential Input Voltage	V _{ID}	150	-	600	mV	-
LVDS Input Voltage	V _{INLV}	0.7	-	1.7	V	-
Common Mode Voltage	V _{CM}	1.0	1.2	1.7- V _{ID} /2	V	-

Note (1) Input signals shall be low or Hi- resistance state when VCC is off.

Note (2) All electrical characteristics for LVDS signal are defined and shall be measured at the interface connector of LCD.

IVO	Document Title	M123AWF4 R0 Product Specification			Page 13 of 31	
	Document No.	M123AWF4-R0	Issue Date	2022/8/31	Ver.	01

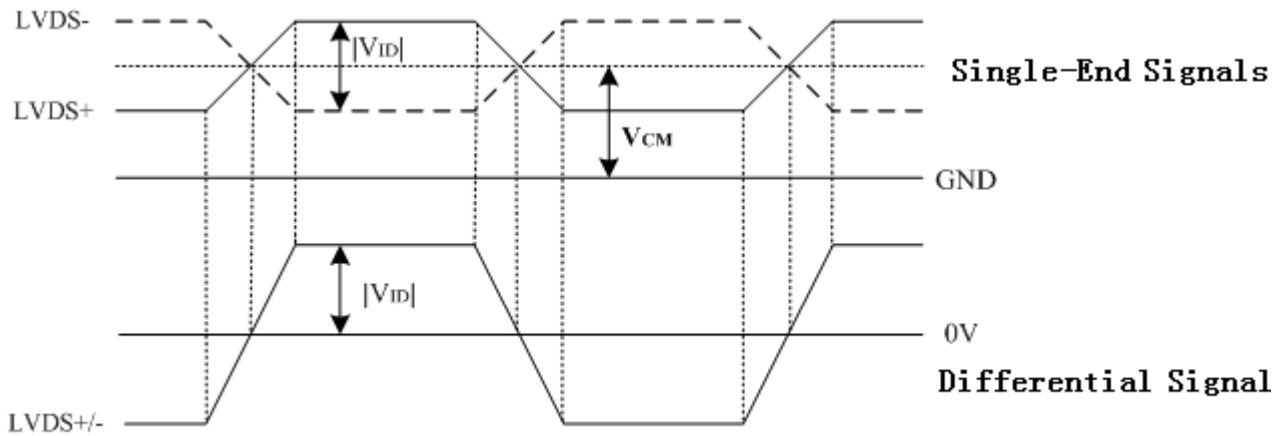



Figure 8 Voltage Definitions

Table 6 LVDS mode AC electrical characteristics

Parameter	Symbol	Spec			Unit
		Min	Typ	Max	
Clock frequency(1-port)	Flvcyc	40.8	-	48.2	MHz
Clock period(1-port)	Tlvcyc	20.7	-	-	ns
1 data bit time	UI	-	1/7	-	Tlvcyc
Clock high time	TLVHW	-	4	-	UI
Clock low time	TLVLW	-	3	-	UI
Position1	Tpos1	-0.2	0	0.2	UI
Position0	Tpos0	0.8	1	1.2	UI
Position6	Tpos6	1.8	2	2.2	UI
Position5	Tpos5	2.8	3	3.2	UI
Position4	Tpos4	3.8	4	4.2	UI
Position3	Tpos3	4.8	5	5.2	UI
Position2	Tpos2	5.8	6	6.2	UI
Input eye width	TEYEW	0.6	-	-	UI
Input eye border	TEX	-	-	0.2	UI
LVDS clock to clock skew	TSKEW_EO	-1	-	1	UI

	Document Title	M123AWF4 R0 Product Specification			Page 14 of 31	
	Document No.	M123AWF4-R0	Issue Date	2022/8/31	Ver.	01

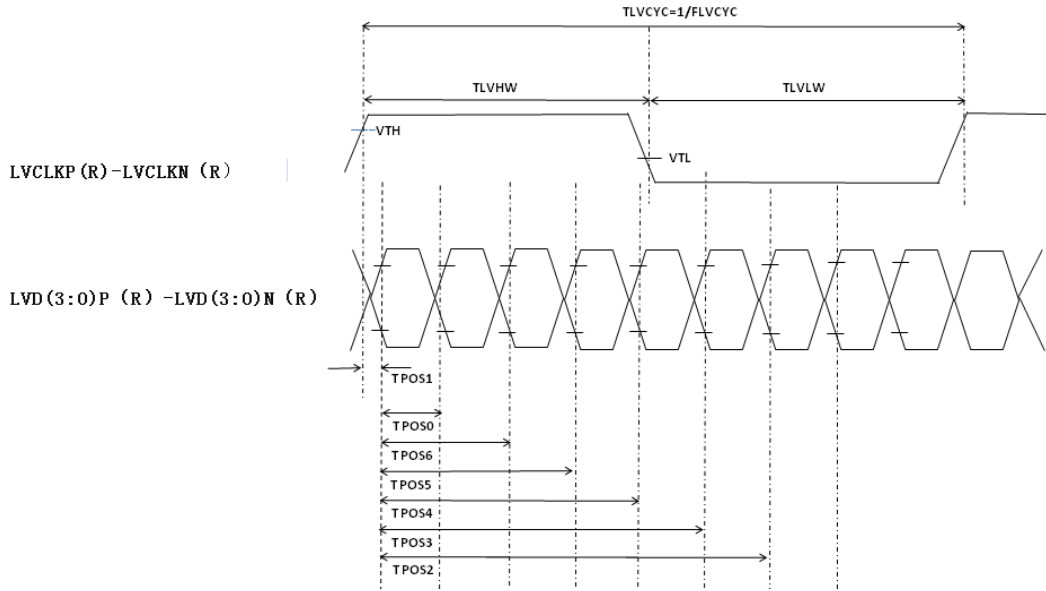

Figure 9 LVDS input timing

Single-ended:
LVDS[3:0]P,
LVDS[3:0]N

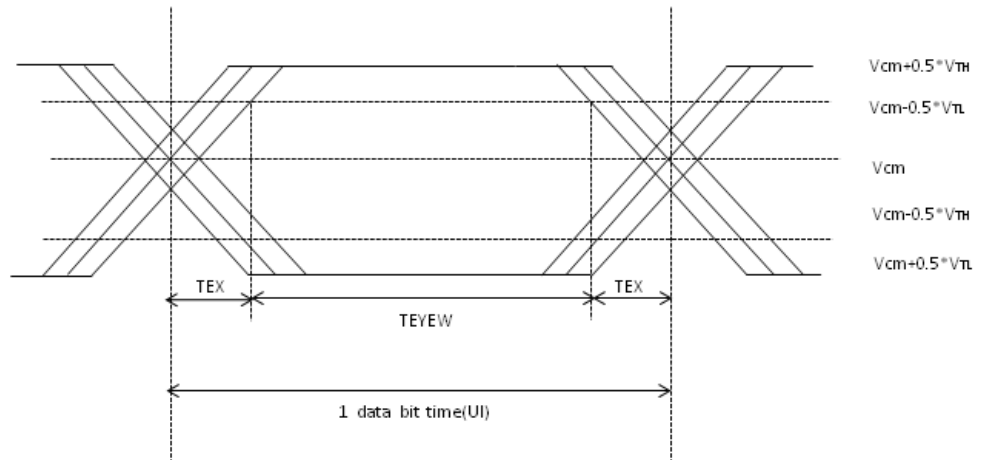



Figure 10 LVDS input eye diagram

	Document Title	M123AWF4 R0 Product Specification			Page 15 of 31	
	Document No.	M123AWF4-R0	Issue Date	2022/8/31	Ver.	01

Differential:
LVD[3:0]P-LVD[3:0]N

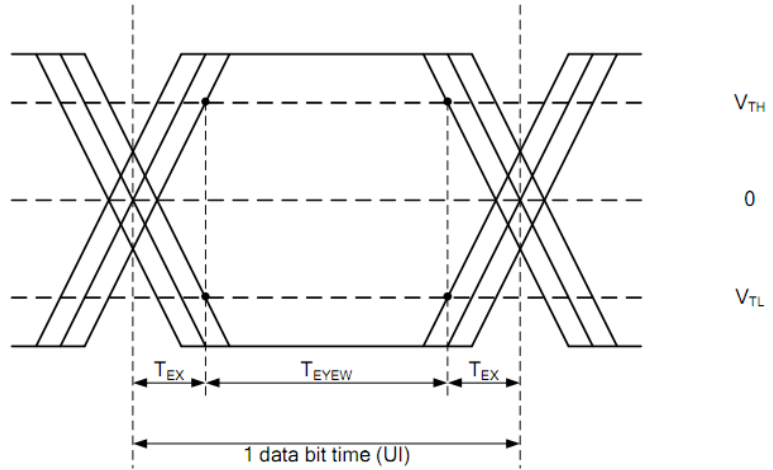

Figure 11 LVDS input eye diagram

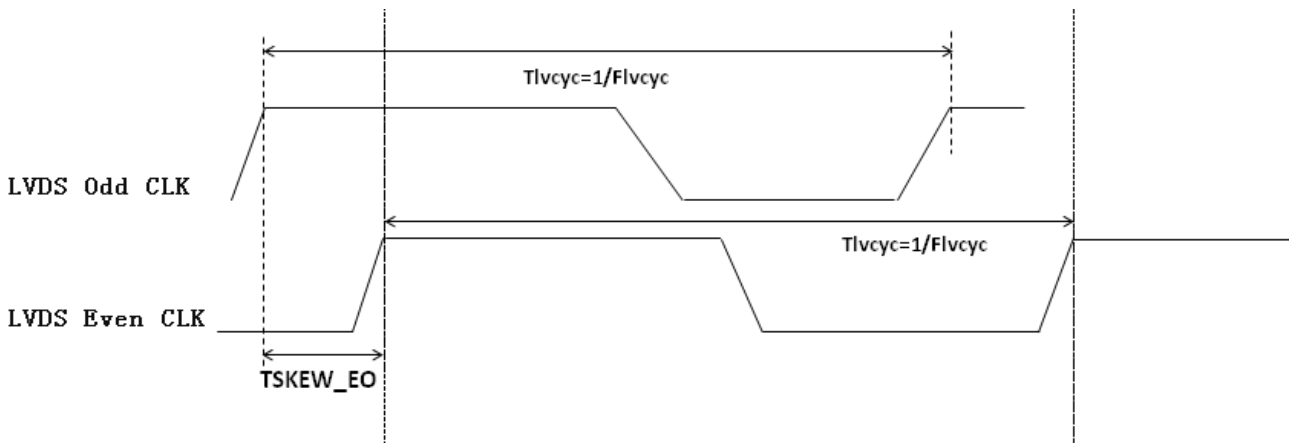

Figure 12 LVDS clock to clock skew

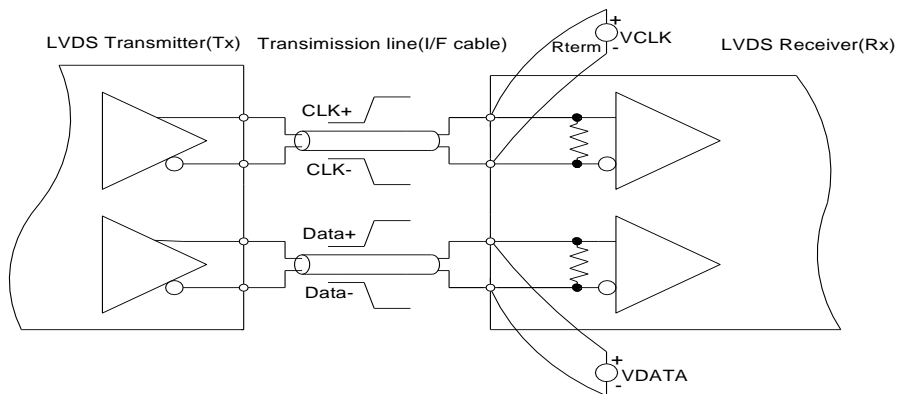



Figure 13 Measurement System

	Document Title	M123AWF4 R0 Product Specification			Page 16 of 31	
	Document No.	M123AWF4-R0	Issue Date	2022/8/31	Ver.	01

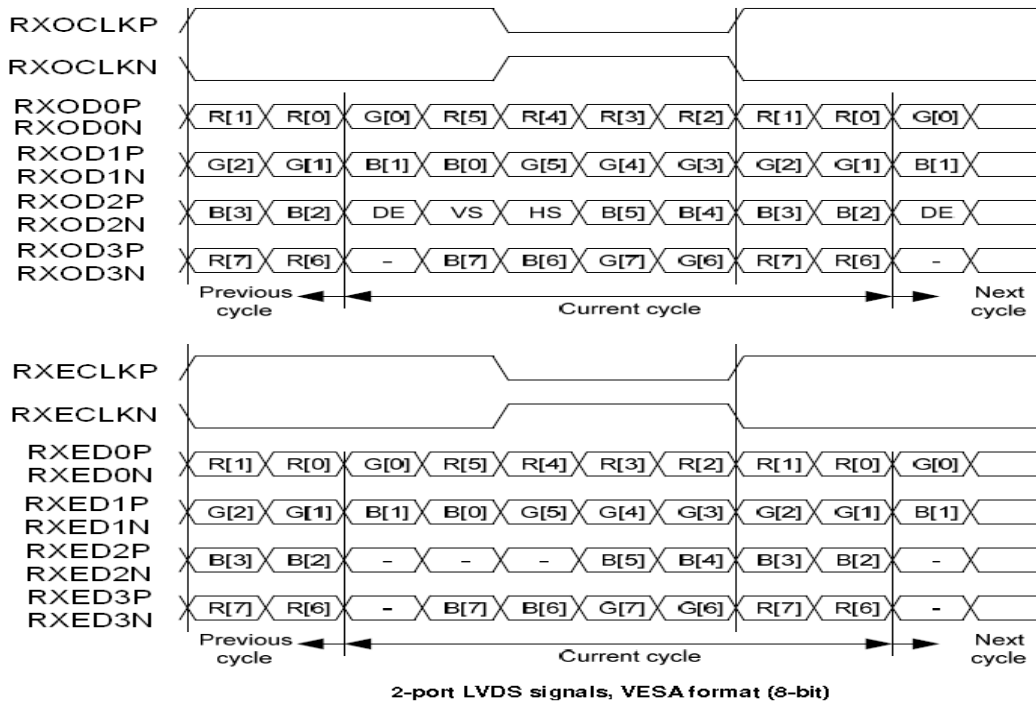



Figure 14 Data Mapping

	Document Title	M123AWF4 R0 Product Specification			Page 17 of 31	
	Document No.	M123AWF4-R0	Issue Date	2022/8/31	Ver.	01

4.2.2 LVDS Receiver Internal Circuit

Figure 11 shows the internal block diagram of the LVDS receiver. This LCD module equips termination resistors for LVDS link.

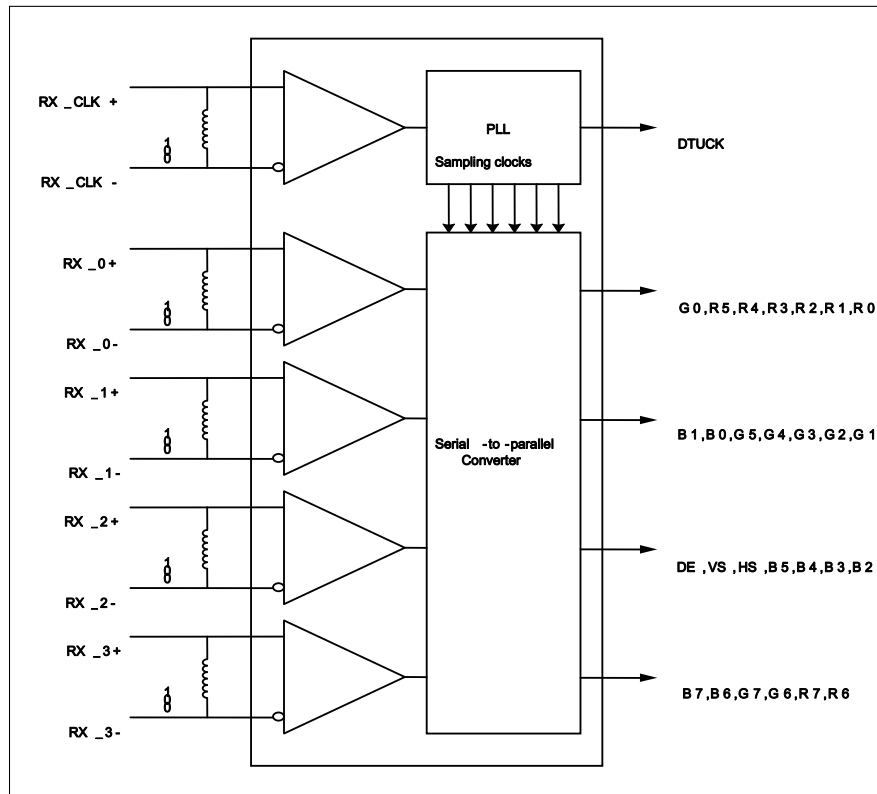



Figure 15 LVDS Receiver Internal Circuit

	Document Title	M123AWF4 R0 Product Specification			Page 18 of 31	
	Document No.	M123AWF4-R0	Issue Date	2022/8/31	Ver.	01

4.3 Interface Timings

Table 6 Interface Timings

Parameter	Symbol	Min.	Typ.	Max.	Unit	Note
LVDS Clock Frequency	Fclk	81.6	89.0	96.5	MHz	(1)
H Total Time	HT	1,975	2030	2880	Clocks	-
H Active Time	HA	1920			Clocks	-
V Total Time	VT	728	731	1080	Lines	-
V Active Time	VA	720			Lines	-
Frame Rate	FV	55	60	65	Hz	-

Note1: This module actually uses 2-port.

Note2: $HT * VT * \text{Frame Frequency} \leq 48.25\text{MHz}$ (1-port) .

Note3: All reliabilities are specified for timing specification based on refresh rate of 60Hz.

DE Only Mode

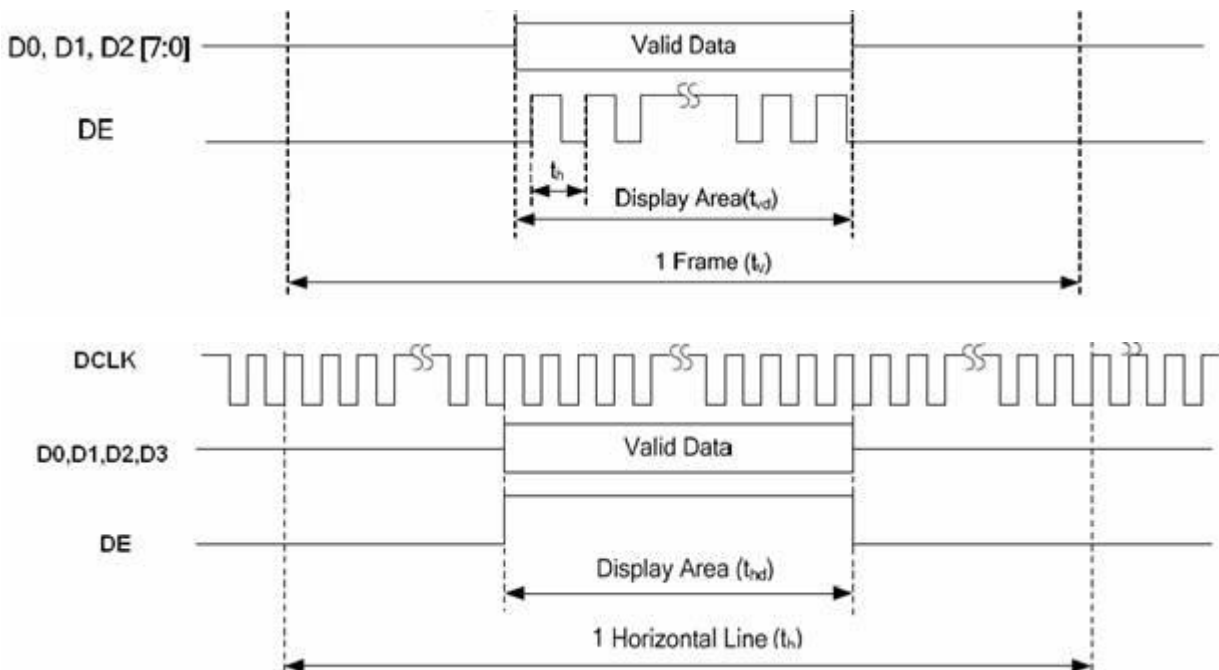

Figure 16 Timing Diagram

4.4 Input Power Specifications

Input power specifications are as follows.

InfoVision Optoelectronics (Kunshan) Co.,LTD.

	Document Title	M123AWF4 R0 Product Specification			Page 19 of 31	
	Document No.	M123AWF4-R0	Issue Date	2022/8/31	Ver.	01

Table 7 Input Power Specifications

Parameter	Symbol	Min.	Typ.	Max.	Unit	Note
<i>System Power Supply</i>						
Power Supply Input Voltage	V_{CC}	3.0	3.3	3.6	V	(1),(2)
Power Supply Input Current	Mosaic I_{CC}	-	-	460	mA	(1),(3)
PCC Power Consumption	Mosaic P_{CC}	-		1.38	W	
Logic Input Signal	High level voltage V_{IH}	3.0	-	3.6	V	(1)
	Low level voltage V_{IL}	0	-	0.4	V	
Logic Output Signal	High level voltage V_{OH}	3.0	-	3.6	V	(1)
	Low level voltage V_{OL}	0	-	0.5	V	
Rush Current	I_{Rush}	-	-	1500	mA	(1),(4)
Allowable Logic/LCD Drive Ripple Voltage	V_{VCC-RP}	-	-	200	mV	(1)
<i>LED Power Supply</i>						
LED Input Voltage	V_{LED}	-	-	36.3	V	(1),(2),(7)
LED Power Consumption	P_{LED}	-	-	13.1	W	(1),(7)
LED Forward Voltage	V_F	-	-	3.3	V	(1),(2),(8)
LED Forward Current	I_F	-	90	-	mA	
LED Life Time	LT	30,000	-	-	Hours	(1),(6)

Note (1) All of the specifications are guaranteed under normal conditions. Normal conditions are defined as follow: Temperature: 25°C, Humidity: 55± 10%RH.

Note (2) All of the absolute maximum ratings specified in the table, if exceeded, may cause faulty operation or unrecoverable damage.It is recommended to follow the typical value.

Note (3) The specified I_{CC} current and power consumption are measured under the $V_{CC} = 3.3 V$, $FV= 60 Hz$ condition and Mosaic pattern.

InfoVision Optoelectronics (Kunshan) Co.,LTD.

	Document Title	M123AWF4 R0 Product Specification			Page 20 of 31	
	Document No.	M123AWF4-R0	Issue Date	2022/8/31	Ver.	01

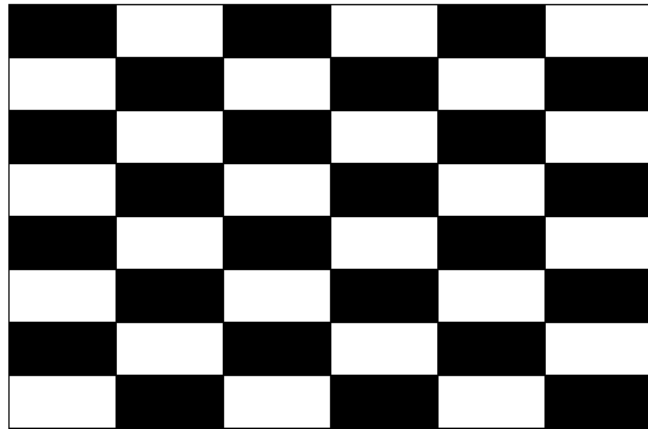

Note (4) The figures below is the measuring condition of V_{CC} Rush current can be measured when T_{RUSH} is 0.5 ms.

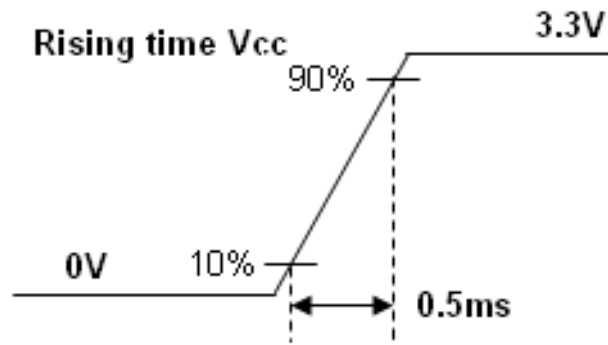

Figure 17 V_{CC} Rising Time

Note (5) Although acceptable range as defined, the dimming ratio is not effective at all conditions. The PWM frequency should be fixed and stable for more consistent luminance control at any specific level desired.

Note (6) The life time is determined as the sum of the lighting time till the luminance of LCD at the typical LED current reducing to 50% of the minimum value under normal operating condition.

Note (7) Definition of VLED and PLED

$$V_{LED} = V_F \times 11, I_{LED} = I_F \times 4, P_{LED} = V_{LED} \times I_{LED}$$

InfoVision Optoelectronics (Kunshan) Co.,LTD.

	Document Title	M123AWF4 R0 Product Specification			Page 21 of 31	
	Document No.	M123AWF4-R0	Issue Date	2022/8/31	Ver.	01

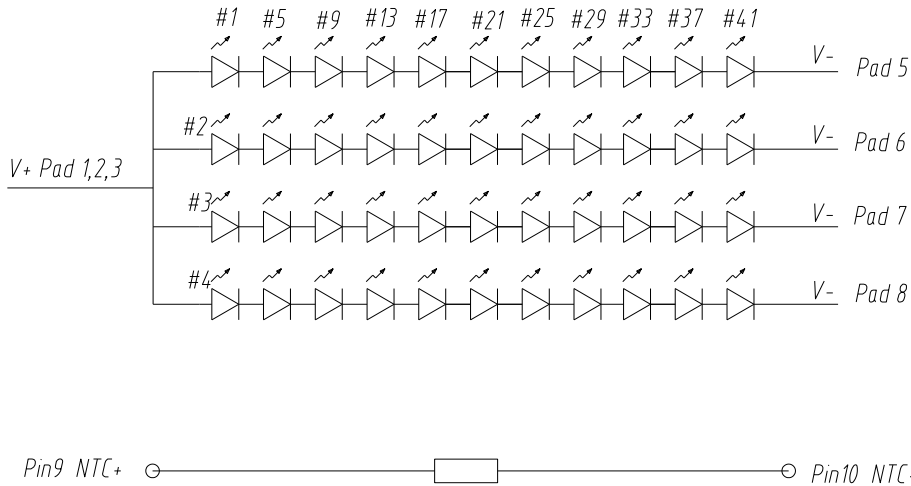

Note (8) The allowable forward current of LED vary with environmental temperature (Type: Murata NCU15XH103F6SRC):

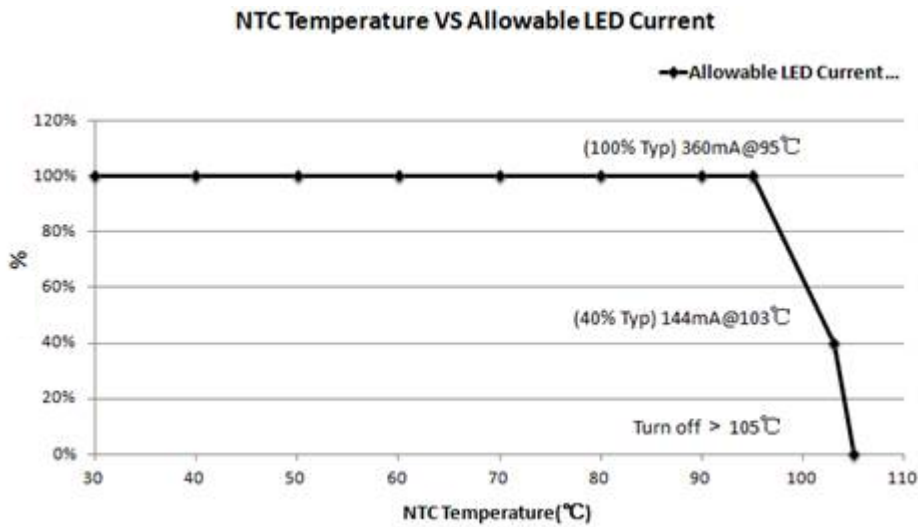

Figure 18 Backlight Current De-rating Curve

InfoVision Optoelectronics (Kunshan) Co.,LTD.



	Document Title	M123AWF4 R0 Product Specification			Page 22 of 31	
	Document No.	M123AWF4-R0	Issue Date	2022/8/31	Ver.	01

Table 9 The relationship of temperature and resistance for NTC

Temperature/°C	Resistance/Kohm	Temperature/°C	Resistance/Kohm
-40	195.652	60	3.014
-35	148.171	65	2.586
-30	113.347	70	2.228
-25	87.559	75	1.925
-20	68.237	80	1.669
-15	53.650	85	1.452
-10	42.506	90	1.268
-5	33.892	95	1.110
0	27.219	100	0.974
5	22.021	105	0.858
10	17.926	110	0.758
15	14.674	115	0.672
20	12.081	120	0.596
25	10.000	125	0.531
30	8.315	130	0.474
35	6.948	135	0.424
40	5.834	140	0.381
45	4.917	145	0.342
50	4.161	150	0.309
55	3.535		

	Document Title	M123AWF4 R0 Product Specification			Page 23 of 31	
	Document No.	M123AWF4-R0	Issue Date	2022/8/31	Ver.	01

4.5 Power ON/OFF Sequence

- Interface signals are also shown in the chart. Signals from any system shall be Hi-resistance state or low level when VCC voltage is off.
- When system first start up, should keep the VCC high time longer than 200ms, otherwise may cause image sticking when VCC drop off.

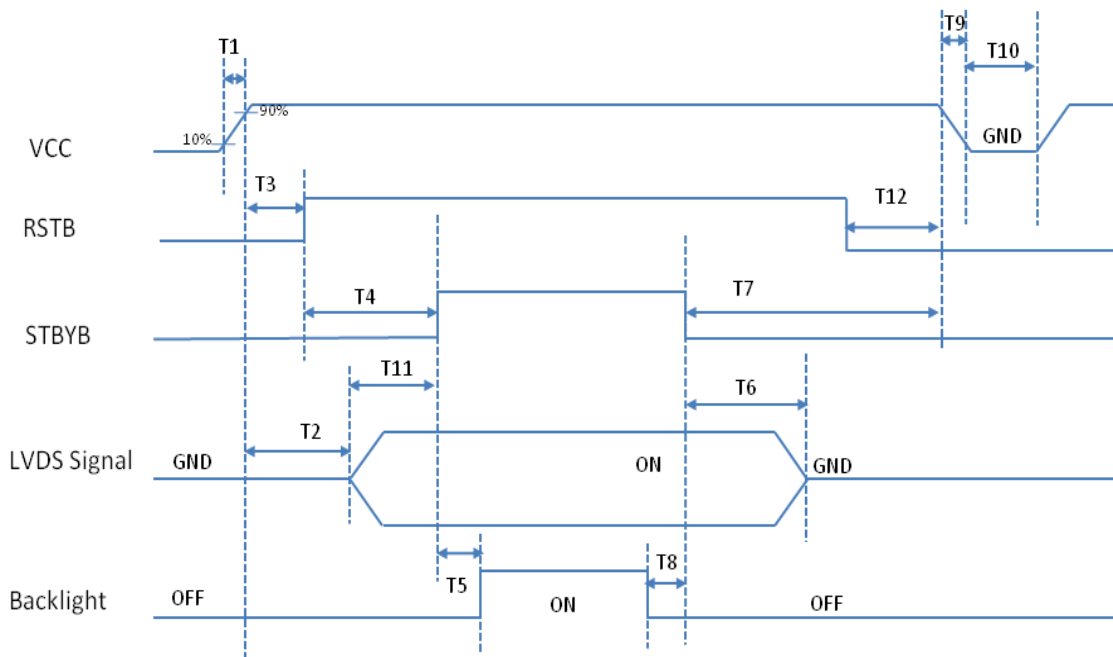



Figure 19 Power Sequence

Table 10 Power Sequencing Requirements

Parameter	Symbol	Unit	Min.	Typ.	Max.
VCC Rising Time	T1	ms	0.5	-	10
VCC to LVDS	T2	ms	0	-	50
VCC to RSTB	T3	us	10	-	-
RSTB to STBYB pull H	T4	ms	36	-	-
STBYB pull H to BL power On	T5	ms	200	-	-
BL power off to STBYB pull L	T8	ms	200	-	-
STBYB pull L to LVDS Disable	T6	ms	50	67	83
STBYB pull L to VCC Power off	T7	ms	50	67	83
VCC Fall Time	T9	ms	0.5	-	30

InfoVision Optoelectronics (Kunshan) Co.,LTD.

	Document Title	M123AWF4 R0 Product Specification			Page 24 of 31	
	Document No.	M123AWF4-R0	Issue Date	2022/8/31	Ver.	01

VCC Power off	T10	s	0.5	14.2	-
LVDS Enable to STBYB pull high	T11	ms	0	10	-
RSTB pull L to VCC Power off	T12	ms	10	-	-

Note: IVO recommend T6, T7, T10, T11 to setting Typical value. There will be unknown risks if not.

5.0 Mechanical Characteristics

5.1 Outline Drawing

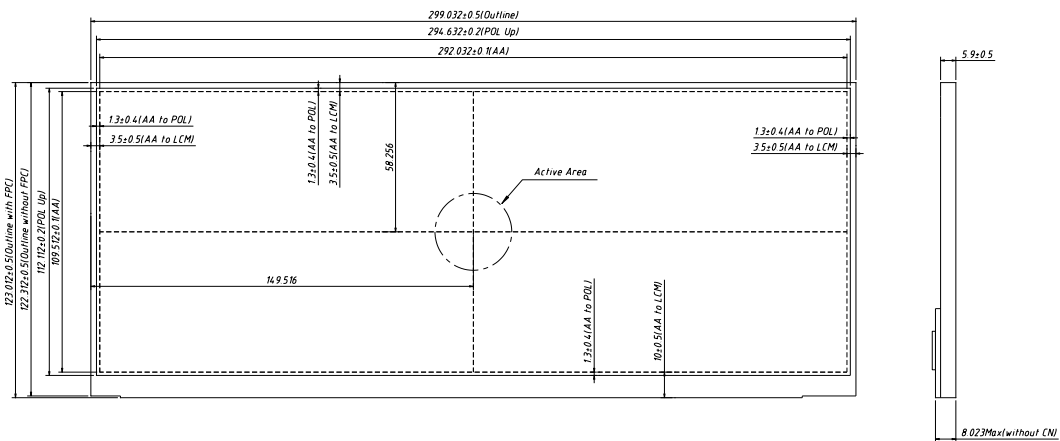
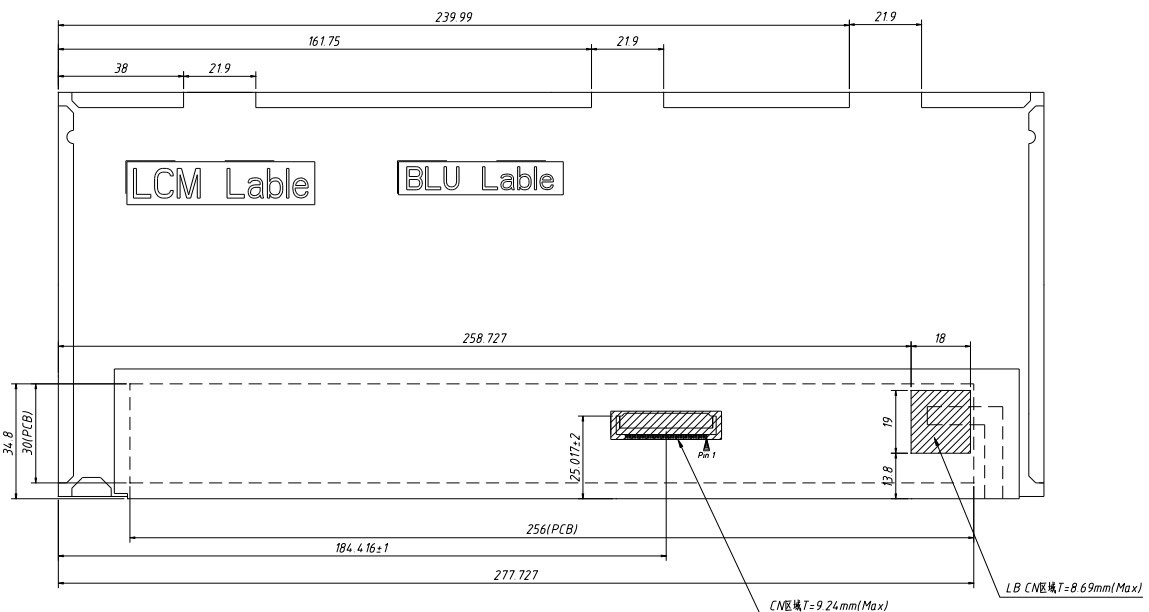



Figure 20 Reference Outline Drawing (Front Side)



Notes: Unmarked tolerance ± 0.5

Figure 21 Reference Outline Drawing (Back Side)

InfoVision Optoelectronics (Kunshan) Co.,LTD.

	Document Title	M123AWF4 R0 Product Specification			Page 25 of 31	
	Document No.	M123AWF4-R0	Issue Date	2022/8/31	Ver.	01

5.2 Dimension Specifications

Table 11 Module Dimension Specifications

Item		Min.	Typ.	Max.	Unit
Width		298.532	299.032	299.532	mm
Height		122.512	123.012	123.512	mm
Thickness	With PCBA	-	-	8.023	mm
Weight		-	348.5	380	g

Note: Outline dimension measure instrument: Vernier Caliper.

6.0 Reliability Conditions

Table 12 Reliability Condition

Item		Package	Test Conditions		Note
High Temperature/High Humidity Operating Test		Module	T _{gs} =60°C, 90%RH, 500 hours		(1),(2),(3),(4), (8)
High Temperature Operating Test		Module	T _{gs} =85°C, 500 hours		
Low Temperature Operating Test		Module	T _a =-30°C, 500 hours		
High Temperature Storage Test		Module	T _a =90°C, 500 hours		(1),(3),(4)
Low Temperature Storage Test		Module	T _a =-40°C, 500 hours		
Shock Non-operating Test		Module	100G,6ms,sin wave,±XYZ×3times,Total 18times		(1),(3),(5)
Vibration Non-operating Test		Module	half-sine Frequency: 8Hz ~ 33Hz Stroke: 1.3mm Sweep: 2.9G 33.3Hz ~ 400Hz X,Z Cycle : 15 minutes 2 hrs for each direction of X,Z ; 4 hours for Y direction		
ESD Test	Operating	Module	Contact	±8KV, 150 pF,R=330Ω	(1),(2),(6)
			Air	±15KV, 150pF, R=330Ω	
Image Sticking	High temperature (65°C)	Module	chessboard 6*8, 1hrs, change 50% Gray pattern,release 15 min, ND 8% invisible.		(1),(2),(7)

Note (1) A sample can only have one test. Outward appearance, image quality and optical data can only be checked at normal conditions according to the IVO document before reliable test. Only check the function of the module after reliability test.

Note (2) The setting of electrical parameters should follow the typical value before reliability test.

InfoVision Optoelectronics (Kunshan) Co.,LTD.

	Document Title	M123AWF4 R0 Product Specification			Page 26 of 31	
	Document No.	M123AWF4-R0	Issue Date	2022/8/31	Ver.	01

Note (3) During the test, it is unacceptable to have condensate water remains. Besides, protect the module from static electricity.

Note (4) The sample must be released for 24 hours under normal conditions before judging. Furthermore, all the judgment must be made under normal conditions. Normal conditions are defined as follow: Temperature: 25°C, Humidity: 55± 10%RH. T_a = Ambient Temperature, T_{gs} = Glass Surface Temperature.

Note (5) The module should be fixed firmly in order to avoid twisting and bending.

Note (6) It could be regarded as pass, when the module recovers from function fault caused by ESD after resetting.

Note (7) It is recommended to follow the nominal parameter specified by IVO before the Image Sticking test. Besides, V_{com} must be adjusted to optimize display quality.

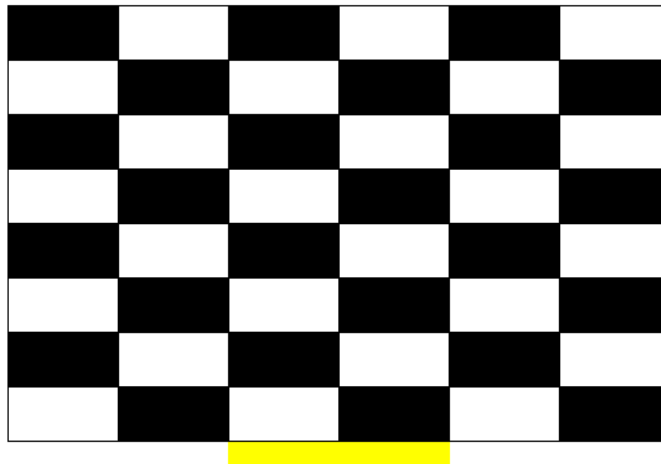



Figure 22 Image Sticking Pattern

Note(8) LED forward current should follow the current of LED vary with environmental temperature (Figure 13 Backlight De-rating Curve)

InfoVision Optoelectronics (Kunshan) Co.,LTD.

	Document Title	M123AWF4 R0 Product Specification			Page 27 of 31	
	Document No.	M123AWF4-R0	Issue Date	2022/8/31	Ver.	01

7.0 Package Specification

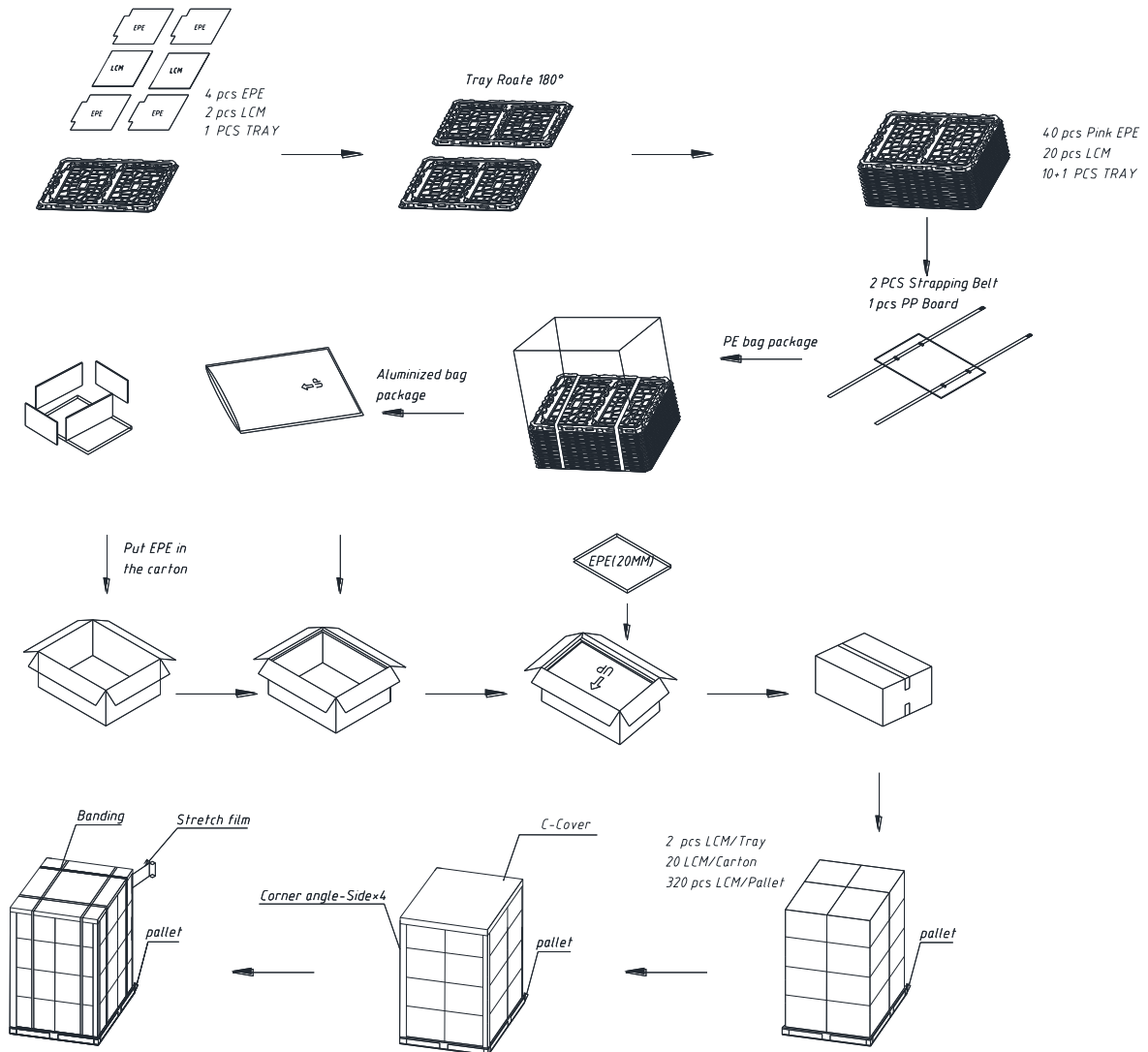



Figure 23 Packing Method

InfoVision Optoelectronics (Kunshan) Co.,LTD.

	Document Title	M123AWF4 R0 Product Specification			Page 28 of 31	
	Document No.	M123AWF4-R0	Issue Date	2022/8/31	Ver.	01

8.0 Lot Mark

8.1 Module label



Note: This picture is only an example.

8.1.1 Lot Mark

1	2	3	4	5	6	7	8	9	10	11	12	13	14	15	16	17	18	19	20
---	---	---	---	---	---	---	---	---	----	----	----	----	----	----	----	----	----	----	----

Code 1,2,4,5,6,7,8,9,10,11,16: IVO internal flow control code.

Code 3: Production Location.

Code 12: Production Year.

Code 13: Production Month.

Code 14,15: Production Day.

Code 17,18,19,20: Serial Number.

8.1.2 23 Customer Code

1	2	3	4	5	6	7	8	9	10	11	12	13	14	15	16	17	18	19	20	21	22	23
---	---	---	---	---	---	---	---	---	----	----	----	----	----	----	----	----	----	----	----	----	----	----

Code 1,2: Manufacture District.

Code 3,4,5,6,7: IVO internal module name.

Code 8,9,10,13,16: IVO internal flow control code.

Code 11,12: Cell location Suzhou, China defined as "KS".

Code 14,15: Module location Kunshan, China defined as "KS"; Yangzhou, China defined as "YZ"; Shenzhen, China defined as "SE"; Zhuhai, China defined as "ZH"; Suzhou, China defined as "SZ".

Code 17,18,19 : Year, Month, Day refer to Note(1), Note(2) and Note(3).

Note (1) Production Year

Year	2006	2007	2008	2009	2010	2011	2012	2013	2035
Mark	6	7	8	9	A	B	C	D	Z

Note (2) Production Month

InfoVision Optoelectronics (Kunshan) Co.,LTD.

	Document Title	M123AWF4 R0 Product Specification				Page 29 of 31	
	Document No.	M123AWF4-R0	Issue Date	2022/8/31	Ver.	01	

Month	Jan.	Feb.	Mar.	Apr.	May.	Jun.	Jul.	Aug.	Sep.	Oct	Nov.	Dec.
Mark	1	2	3	4	5	6	7	8	9	A	B	C

Note (3) Production Day: 1~V.

Code 20~23 : Serial Number.

8.2 Carton label

型號	(Module)	M123AWF4 R0
版本	(Rev.)	HW 1.1 FW 0.0
數量	(QTY)	20PCS / Carton
重量	(Weight)	11.000kg
箱號	(Carton ID)	S011E10K2ZL11500207
		
備註	(Remark)	E10Z000103 ZB

Note: This picture is only an example.

9.0 General Precaution

9.1 Using Restriction

This product is not authorized for using in life supporting systems, aircraft navigation control systems, military systems and any other appliance where performance failure could be life-threatening or lead to be catastrophic.

9.2 Operation Precaution

(1)The LCD product should be operated under normal conditions.

Normal conditions are defined as below:

Temperature: 25°C

Humidity: 55±10%

Display pattern: continually changing pattern (Not stationary)

(2) Brightness and response time depend on the temperature. (It needs more time to reach normal brightness in low temperature.)

(3) It is necessary for you to pay attention to condensation when the ambient temperature drops suddenly. Condensate water would damage the polarizer and electrical contacted parts of the module. Besides, smear or spot will remain after condensate water evaporating.

(4) If the absolute maximum rating value was exceeded, it may damage the module.

(5) Do not adjust the variable resistor located on the module.

InfoVision Optoelectronics (Kunshan) Co.,LTD.

	Document Title	M123AWF4 R0 Product Specification			Page 30 of 31	
	Document No.	M123AWF4-R0	Issue Date	2022/8/31	Ver.	01

- (6) Sufficient suppression to the electromagnetic interference shall be done by system manufacturers. Grounding and shielding may be important to minimize the interference.
- (7) Image sticking may occur when the module displayed the same pattern for long time.
- (8) Do not connect or disconnect the module in the “power on” condition. Power supply should always be turned on/off by the “power on/off sequence”
- (9) Ultra-violet ray filter is necessary for outdoor operation.

9.3 Mounting Precaution

- (1) All the operators should be electrically grounded and with Ion-blown equipment turning on when mounting or handling. Dressing finger-stalls out of the gloves is important for keeping the panel clean during the incoming inspection and the process of assembly.
- (2) It is unacceptable that the material of cover case contains acetic or chloric. Besides, any other material that could generate corrosive gas or cause circuit break by electro-chemical reaction is not desirable.
- (3) The case on which a module is mounted should have sufficient strength so that external force is not transmitted to the module directly.
- (4) It is obvious that you should adopt radiation structure to satisfy the temperature specification.
- (5) So as to acquire higher luminance, the cable of the power supply should be connected directly with a minimize length.
- (6) It should be attached to the system tightly by using all holes for mounting, when the module is assembled. Be careful not to apply uneven force to the module, especially to the PCB on the back.
- (7) A transparent protective film needs to be attached to the surface of the module.
- (8) Do not press or scratch the polarizer exposed with anything harder than HB pencil lead. In addition, don't touch the pin exposed with bare hands directly.
- (9) Clean the polarizer gently with absorbent cotton or soft cloth when it is dirty.
- (10) Wipe off saliva or water droplet as soon as possible. Otherwise, it may cause deformation and fading of color.
- (11) Clean the panel gently with absorbent cotton or soft cloth when it is dirty. Ethanol(C_2H_5OH) is allowed to be used. Ketone (ex. Acetone), Toluene, Ethyl acid, Methyl chloride, etc are not allowed to be used for cleaning the panel, which might react with the polarizer to cause permanent damage.
- (12) Do not disassemble or modify the module. It may damage sensitive parts in the LCD module, and cause scratches or dust remains. IVO does not warrant the module, if you disassemble or modify the module.

9.4 Handling Precaution

- (1) Static electricity will generate between the film and polarizer, when the protection film is peeled off. It should be peeled off slowly and carefully by operators who are electrically grounded and with Ion-blown equipment turning on. Besides, it is recommended to peel off the film from the bonding

InfoVision Optoelectronics (Kunshan) Co.,LTD.

	Document Title	M123AWF4 R0 Product Specification			Page 31 of 31	
	Document No.	M123AWF4-R0	Issue Date	2022/8/31	Ver.	01

area.

(2) The protection film is attached to the polarizer with a small amount of glue. When the module with protection film attached is stored for a long time, a little glue may remain after peeling.

(3) If the liquid crystal material leaks from the panel, keep it away from the eyes and mouth. In case of contact with hands, legs or clothes, it must be clean with soap thoroughly.

9.5 Storage Precaution

When storing modules as spares for long time, the following precautions must be executed.

(1) Store them in a dark place. Do not expose to sunlight or fluorescent light. Keep the temperature between 5°C and 35°C at normal humidity.

(2) The polarizer surface should not come in contact with any other object. It is recommended that they be stored in the container in which they were shipped.

(3) It is recommended to use it in a short-time period, after it's unpacked. Otherwise, we would not guarantee the quality.

9.6 Others

When disposing LCD module, obey the local environmental regulations.