

MODEL NO : TM156VDSG16

MODEL VERSION: 00

SPEC VERSION : V1.0

ISSUED DATE: 2019-11-04

Document number: PDB-工业 1-19-C-130

- Preliminary Specification
 Final Product Specification

Customer : _____

Approved by	Notes

TIANMA Confirmed :

Prepared by	Checked by	Approved by
Yongqiang_Han		

This technical specification is subjected to change without notice

The information contained herein is the exclusive property of Tianma Microelectronics Co., Ltd, and shall not be distributed, reproduced, or disclosed in whole or in part without prior written permission of Tianma Microelectronics Co., Ltd.

Table of Contents

Table of Contents.....	2
Record of Revision	3
1 General Specifications	4
2 Input/Output Terminals	5
2.1 TFT LCD Panel.....	5
2.2 Positions of Socket	6
3 Absolute Maximum Ratings	7
4 Electrical Characteristics.....	8
4.1 Driving TFT LCD Panel.....	8
4.2 Driving Backlight.....	8
4.3 Block Diagram	10
5 Timing Chart	11
5.1 Timing Characteristics	11
5.2 Input Signal Timing Chart.....	12
5.3 Power On/Off Sequence	13
5.4 eDP SIGNAL TIMING SPECIFICATIONS	15
6 Optical Characteristics	16
7 Environmental / Reliability Test	20
8 Mechanical Drawing.....	21
9 Packing Drawing	22
10 Precautions For Use of LCD Modules.....	22
10.1 Handling Precautions.....	22
10.2 Storage Precautions	23
10.3 Transportation Precautions	23

Record of Revision

Rev	Issued Date	Description	Editor
1.0	2019-7-29	Preliminary Specification Released.	Han Yongqiang

1 General Specifications

	Feature	Spec
Display Spec.	Size (inch)	15.6
	Resolution	1920(RGB) x 1080
	Technology Type	SFT
	Pixel Configuration	R.G.B. Vertical Stripe
	Pixel Pitch (mm)	0.17925 x 0.17925
	Display Mode	Transmissive, Normally Black
	Polarizer pencil-hardness	3H (min.) [by JIS K5600]
	Surface Treatment (Up Polarizer)	Antiglare
	Viewing Direction	-
	Gray Scale Inversion Direction	-
Optical Characteristics	Luminance (cd/m ²)	400 Typ.
	Contrast ratio	1000:1 Typ.
	Color gamut (%)	72 Typ.
	Response time Ton+Toff (ms)	25 Typ.
	Viewing angle R/L/U/D (Degree)	88/88/88/88 Typ.
Mechanical Characteristics	LCM (W x H x D) (mm)	363.8 x 215.9 x 6.3 Typ.
	Active Area (mm)	344.16 x 193.59
	With /Without TSP	Without TSP
	Weight (g)	(610) Typ.
	Backlight LED replacement	Not Available
Electrical Characteristics	Interface	eDP 2lines, 8bit
	Power supply voltage (V)	LCD panel: 3.3 Typ.
		Backlight: 12.0 Typ.
	Color Depth	16.7M
	Backlight LED driver	Build in.
Power consumption (W)	(13.9) Typ.	

Note 1: The 12 o'clock direction is upper side of outline in **"8 Mechanical Drawing"**.

Note 2 : Requirements on Environmental Protection: Q/S0002

Note 3 : LCM weight max. tolerance : +10%

Note 4: Color gamut is against NTSC color space.

Note 5: Power consumption is defined at the maximum luminance control, with checkered flag pattern.

2 Input/Output Terminals

2.1 TFT LCD Panel

CN1 socket (LCD module side): 20455-040E (IPEX)

Adaptable plug: 20453-240T-11 (IPEX, Plug Set)

20454-240T (IPEX, HOUSING) or equivalent

Pin	Signal Name	Description	Remarks
1	N.C.	Keep this pin Open.	-
2	N.C.		
3	N.C.		
4	N.C.		
5	N.C.		
6	N.C.		
7	N.C.		
8	H_GND	High Speed Ground	Note1
9	Lane1_N	Complement Signal Link Lane 1	-
10	Lane1_P	True Signal Link Lane 1	-
11	H_GND	High Speed Ground	Note1
12	Lane0_N	Complement Signal Link Lane 0	-
13	Lane0_P	True Signal Link Lane 0	-
14	H_GND	High Speed Ground	Note1
15	AUX_CH_P	True Signal Auxiliary Channel	-
16	AUX_CH_N	Complement Signal Auxiliary Channel	-
17	H_GND	High Speed Ground	Note1
18	VCC	Power supply for LCD panel signal processing board	Note1
19	VCC		
20	VCC		
21	VCC		
22	RSVD	Keep this pin Open.	-
23	GND	Ground	Note1
24	GND		
25	GND		
26	GND		
27	HPD	HPD Signal Pin	-
28	GNDB	LED driver ground	Note1
29	GNDB		
30	GNDB		
31	GNDB		
32	BRTC	Backlight ON/OFF control High or Open: ON Low: OFF	-
33	PWM	PWM signal input for dimming (Luminance control)	-
34	N.C.	Keep this pin Open.	-
35	N.C.		
36	VDD	Power supply for LED driver	Note1
37	VDD		
38	VDD		
39	VDD		
40	N.C.	Keep this pin Open.	-

Note1: All H_GND, GND, GNDB, VCC and VDD terminals should be used without any non-connected lines

2.2 Positions of Socket

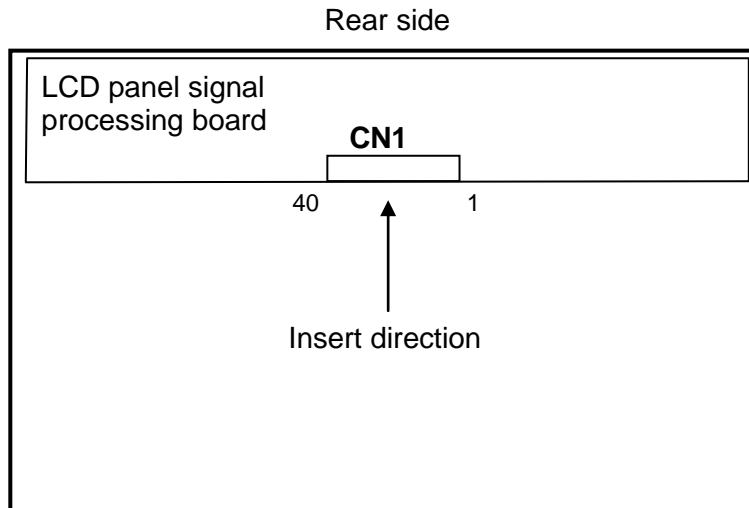

3 Absolute Maximum Ratings

GND=0V

Parameter		Symbol	Rating	Unit	Remarks
Power supply voltage	LCD panel signal processing board	VCC	-0.3to +4.0	V	Ta= 25°C
	LED driver	VDD	0.3to +15.0		
Input voltage for signals	Display signals	VD	-0.3to +4.0	V	
	Function signal for LED driver	PWM	-0.3to +5.5	V	
		BRTC	-0.3to +5.5	V	
Storage temperature		Tst	-20 to +70	°C	
Operating temperature	Front surface	TopF	-20 to +70	°C	Note1
	Rear surface	TopR	-20 to +70	°C	Note2
Relative humidity Note3		RH	≤ 95	%	Ta ≤ 40°C
			≤ 85	%	40°C < Ta ≤ 50°C
			≤ 55	%	50°C < Ta ≤ 60°C
			≤ 36	%	60°C < Ta ≤ 70°C
Absolute humidity Note3		AH	≤ 70 Note4	g/m ³	Ta = 70°C

Note1: Measured at LCD panel surface (including self-heat)

Note2: Measured at LCD module's rear shield surface (including self-heat)

Note3: No condensation

Note4: Water amount at Ta= 70°C and RH= 36%

4 Electrical Characteristics

4.1 Driving TFT LCD Panel

(Ta= 25°C)

Parameter	Symbol	min.	typ.	max.	Unit	Remarks
Power supply voltage	VCC	3.0	3.3	3.6	V	-
Power supply current	ICC	-	580 Note1	1000 Note2	mA	at VCC= 3.3V
Permissible ripple voltage	VRPC	-	-	100	mVp-p	for VCC Note3, Note4, Note5

Note1: Checkered flag pattern [by IEC 61747-6]

Note2: Pattern for maximum current

Note3: This product works if the ripple voltage levels are over the permissible values, but there might be noise on the display image.

Note4: The permissible ripple voltage includes spike noise.

Note5: The load variation influence does not include.

4.2 Driving Backlight

(Ta= 25°C)

Parameter	Symbol	min.	typ.	max.	Unit	Remarks	
Power supply voltage	VDD	10.8	12.0	13.2	V	Note1	
Power supply current Note2	IDD	-	1,000	1400 Note3	mA	at VDD= 12.0V Note4	
Permissible ripple voltage	VRPD	-	-	200	mVp-p	for VDD Note2, Note5, Note6	
Input voltage for PWM signal	High	VDFH1	2.0	-	5.0	V	Note7
	Low	VDFL1	0	-	0.4	V	
Input voltage for BRTC signal	High	VDFH2	2.0	-	5.0	V	
	Low	VDFL2	0	-	0.8	V	
Input current for PWM signal	High	IDFH1	-	-	300	μA	
	Low	IDFL1	-300	-	-	μA	
Input current for BRTC signal	High	IDFH2	-	-	300	μA	
	High	IDFL2	-300	-	-	μA	
PWM frequency	f _{PWM}	200	-	1k	Hz	Note8, Note9	
PWM duty ratio	DR _{PWM}	1	-	100	%	Note10, Note11	
PWM pulse width	t _{PWH}	20	-	-	μs		
LED life time	Hr	-	50000	-	Hour	Note 12	

Note1: When designing of the power supply, take the measures for the prevention of surge voltage.

Note2: The power supply lines (VDD and GND) may have ripple voltage during luminance control of LED. There is the possibility that the ripple voltage produces acoustic noise and signal wave noise in audio circuit and so on.

Note3: This value excludes peak current such as overshoot current.

Note4: At the maximum luminance control.

Note5: This product works if the ripple voltage levels are over the permissible values, but there might be noise on the display image.

Note6: The permissible ripple voltage includes spike noise.

Note7: See "**4.4 BLOCK DIAGRAM**".

Note8: A recommended fPWM value is as follows.

$$f_{\text{PWM}} = \frac{2n-1}{4} \times f_v$$

(n = integer, f_v = frame frequency of LCD module)

Note9: Depending on the frequency used, some noise may appear on the screen, please conduct a thorough evaluation.

Note10: While the BRTC signal is high, do not set the tPWH (PWM pulse width) is less than minimum value. It may cause abnormal working of the backlight. In this case, turn the backlight off and then on again by BRTC signal.

Note11: Regardless of the PWM frequency, both PWM duty ratio and PWM pulse width must be always more than the minimum values.

Note12: Optical performance should be evaluated at Ta=25°C. Only If LED is driven by high current, high ambient temperature & humidity condition. The life time of LED will be reduced. Operating life means brightness goes down to 50% of initial brightness. Typical operating life time is an estimated data.

4.3 Block Diagram

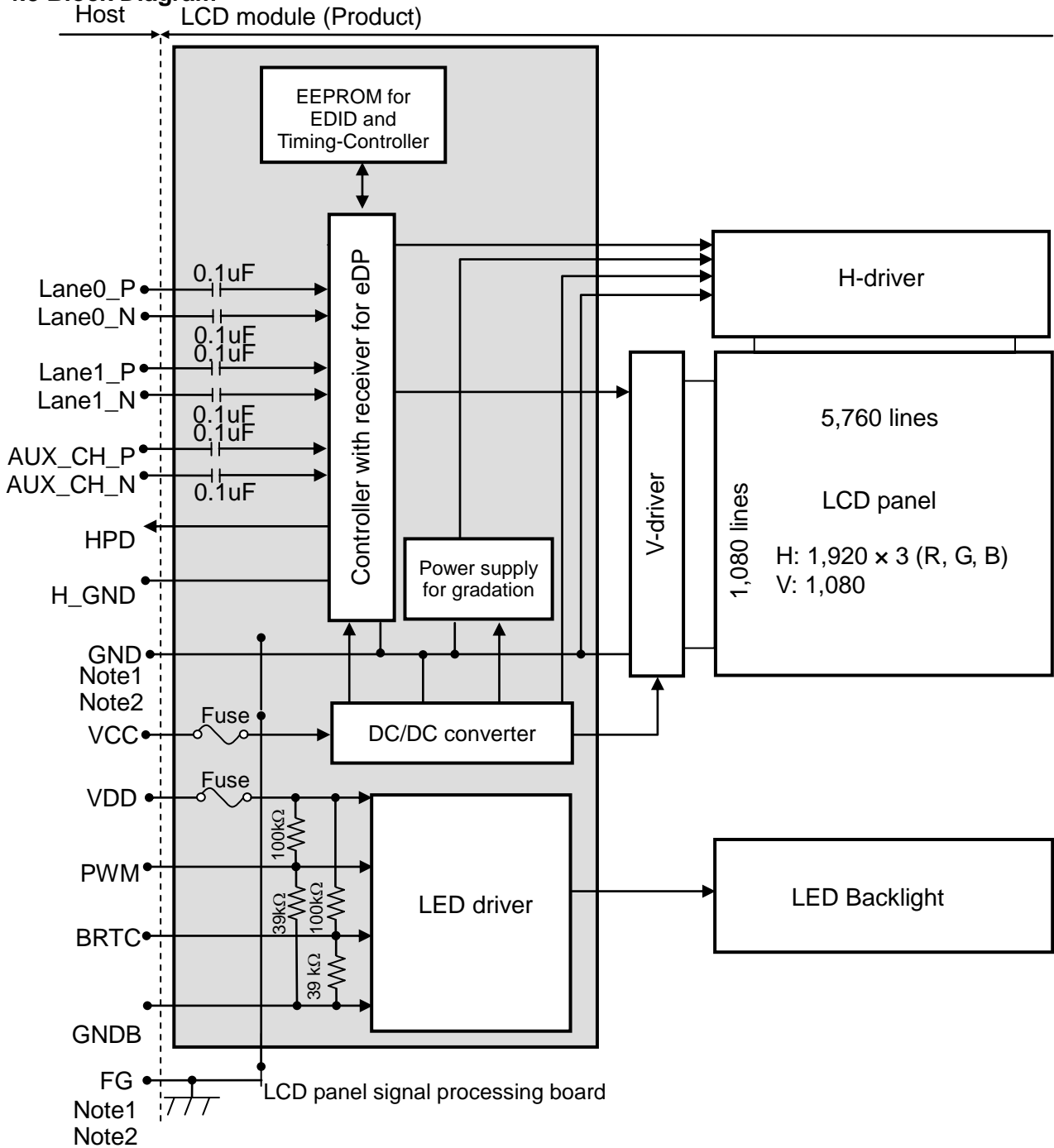

Note1: Relation between H_GND (High Speed Ground), GND (Signal ground), GNDB (LED driver ground) and FG (Frame ground) in the LCD module are as follows.

H_GND- GND	Connected
H_GND- GNDB	Connected
H_GND- FG	Connected
GND- GNDB	Connected
GND- FG	Connected
GNDB- FG	Connected

Note2: H_GND, GND, GNDB and FG must be connected to customer equipment's ground,

and it is recommended that these grounds to be connected together in customer equipment.

5 Timing Chart

5.1 Timing Characteristics

(Note1)

Parameter		Symbol	min.	typ.	max.	Unit	Remarks	
CLK	Frequency	1/tc	111.0	138.5	166.5	MHz	-	
	Duty ratio	-	-			-	-	
	Rise time, Fall time	-				ns		
DE	Horizontal	Cycle	th	-	15.02	-	μs	66.59 kHz (typ.)
		Display period	thd	2,040	2,080	2,280		
	Vertical (One frame)	Cycle	tv	-	16.70	-	ms	59.88Hz (typ.)
		Display period	tvd	1,111	1,112	1,212	H	
				1,080				-

Note1: Definition of parameters is as follows.
tc= 1CLK, th= 1H

5.2 Input Signal Timing Chart

Horizontal timing

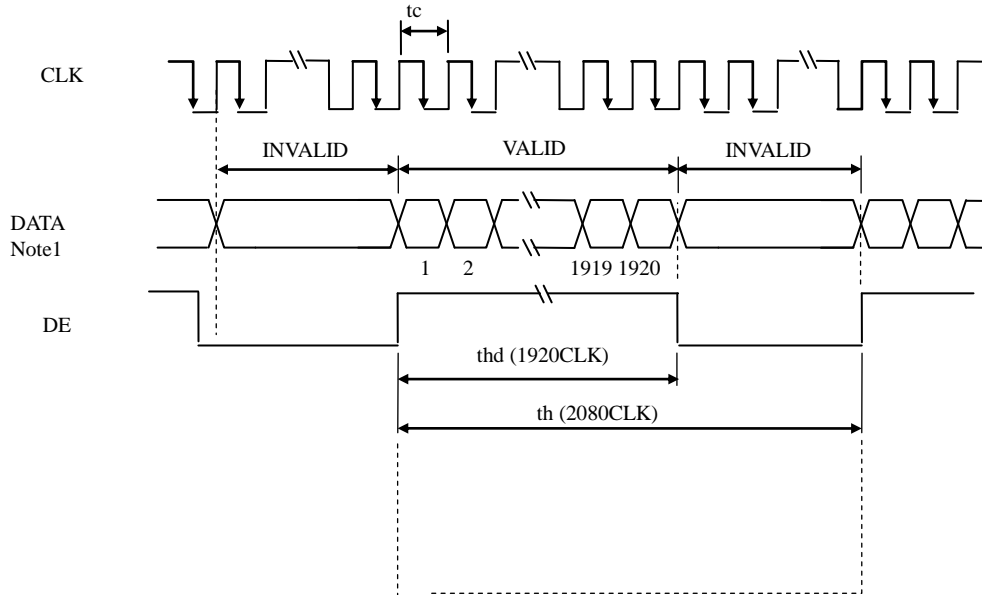

Vertical timing

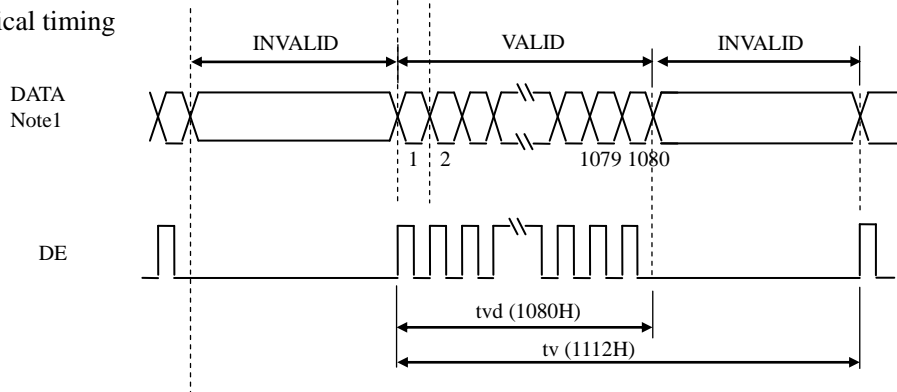

Note1: DATA = R0-R7, G0-G7, B0-B7

5.3 Power On/Off Sequence

5.3.1 LCD panel signal processing board

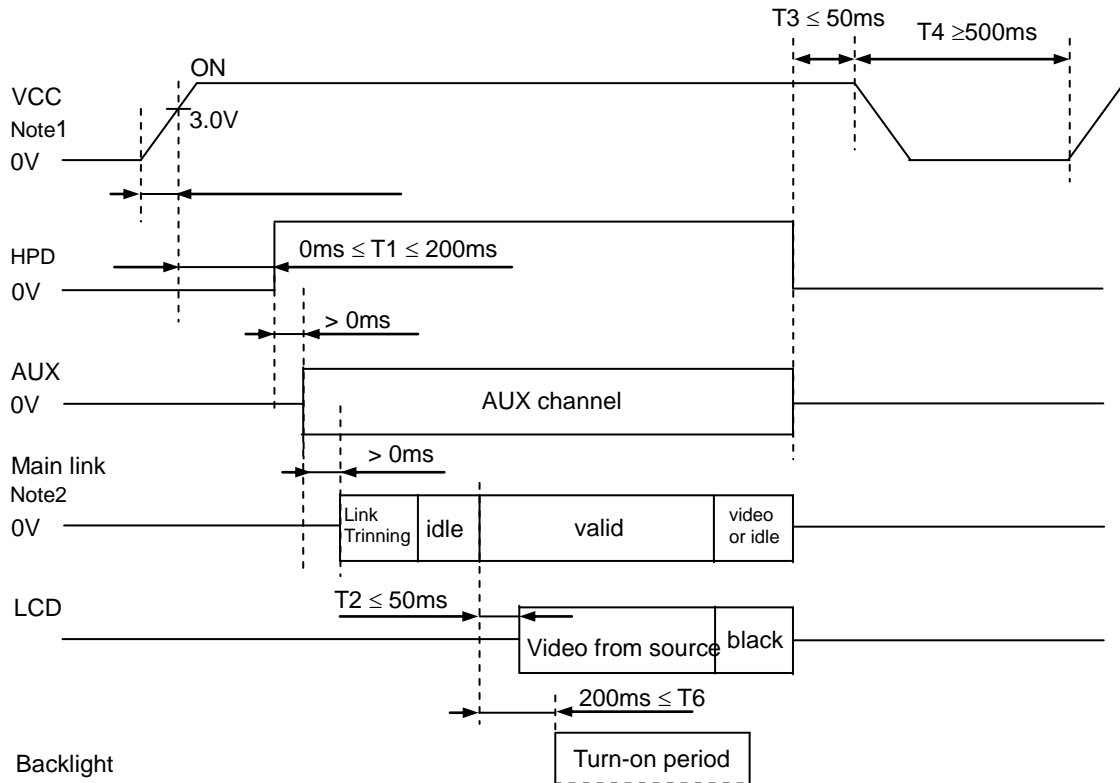

Note1: If there is a voltage variation (voltage drop) at the rising edge of VCC below 3.0V, there is a possibility that a product does not work due to a protection circuit.

Note2: Display signals (Lane0_P/N, Lane1_P/N) must be set to Low or High-impedance, except the VALID period (See above sequence diagram), in order to avoid the circuitry damage.
 If some of display and function signals of this product are cut while this product is working, even if the signal input to it once again, it might not work normally. If a customer stops the display and function signals, VCC also must be shut down.

5.3.2 LED driver

The information contained herein is the exclusive property of Tianma Microelectronics Co., Ltd, and shall not be distributed, reproduced, or disclosed in whole or in part without prior written permission of Tianma Microelectronics Co., Ltd.

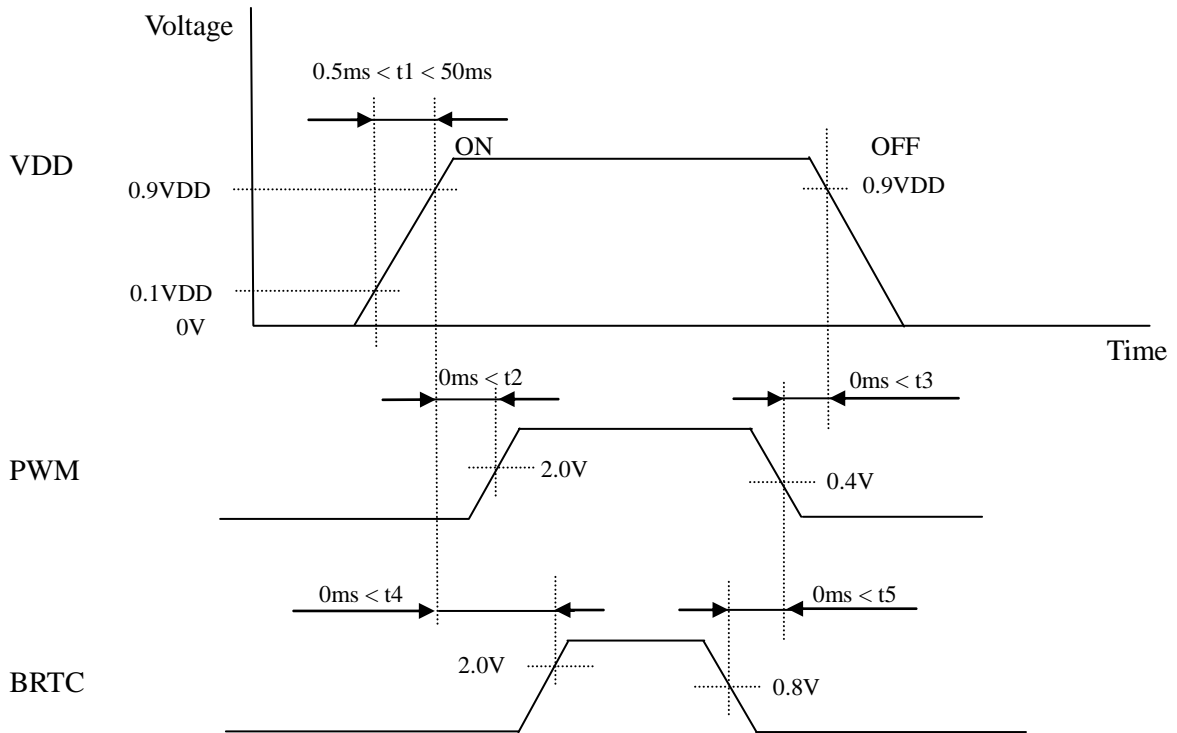

5.4 eDP SIGNAL TIMING SPECIFICATIONS

5.4.1 Display port main link signal

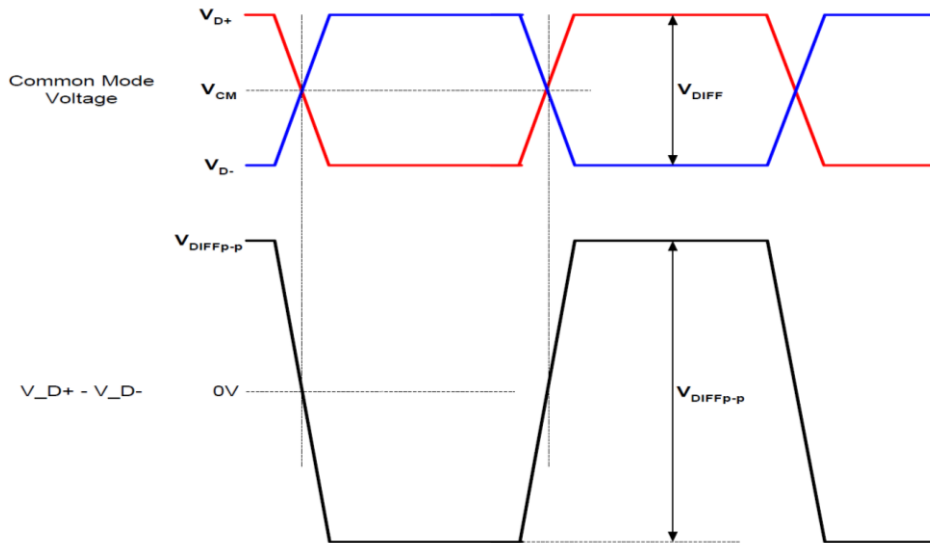

Parameter	Symbol	min.	typ.	max.	Unit	Remarks
Differential peak-to-peak input voltage	V _{DIFFp-p}	100	-	1,320	mV	-
Rx input DC common mode voltage	V _{CM}	-	0	-	V	-
Jitter tracking bandwidth	-	10	-	-	MHz	-
Link clock down spreading	-	-	0.5	-	%	-

5.4.2 Display port HPD signal

Description	Symbol	min.	typ.	max.	Unit	Remarks
Hot plug detect	HPD	2.0	-	2.5	V	I/O type: LVTTTL

5.4.3 Display port AUX signal

Description	Symbol	min.	typ.	max.	Unit	Remarks
AUX differential peak-to-peak voltage When driving	-	0.4	-	1	V	-
AUX differential peak-to-peak voltage When receiving	-	0.25	-	1.36	V	-
AUX common-mode voltage When transmitting	-	-	0.15	-	V	-
AUX common-mode voltage When receiving	-	-	GND	-	V	-
AUX differential termination resistance	-	80	100	120	Ω	-
Unit interval	-	0.4	0.5	0.6	μs	-
Cycle-toCycle jitter time	-	-	-	0.04	UI	-

6 Optical Characteristics

Ta=25°C

Item	Symbol	Condition	Min	Typ	Max	Unit	Remark	
View Angles	θT	$CR \geq 10$	70	88	-	Degree	Note 2	
	θB		70	88	-			
	θL		70	88	-			
	θR		70	88	-			
Contrast Ratio	CR	$\theta=0^\circ$	600	1000	-	-	Note1 Note3	
Response Time	$T_{ON}+T_{OFF}$	25°C	-	25	40	ms	Note1 Note4	
Chromaticity	White	x	Backlight is on	0.263	0.313	0.363	-	Note5 Note1
		y		0.279	0.329	0.379		
	Red	x		-	0.630	-		
		y		-	0.335	-		
	Green	x		-	0.290	-		
		y		-	0.620	-		
	Blue	x		-	0.155	-		
		y		-	0.065	-		
Uniformity	U	-	72	80	-	%	Note1 Note6	
NTSC	-	-	65	72	-	%	Note 5	
Luminance	L		280	400	-	cd/m ²	Note1 Note7	

Test Conditions:

1. The ambient temperature is $25 \pm 2^\circ\text{C}$. humidity is $65 \pm 7\%$. PWM duty ratio is 100%.
2. The test systems refer to Note 1 and Note 2.
3. Contrast Ratio, Chromaticity, Uniformity, and Luminance is measured by SR-UL, SR-3AR or equivalent.
4. Response Time is measured by TRD-100, LCD-5200 or equivalent.

Note 1: Definition of optical measurement system.

The optical characteristics should be measured in dark room. After 20 minutes operation, the optical properties are measured at the center point of the LCD screen. All input terminals LCD panel must be ground when measuring the center area of the panel.

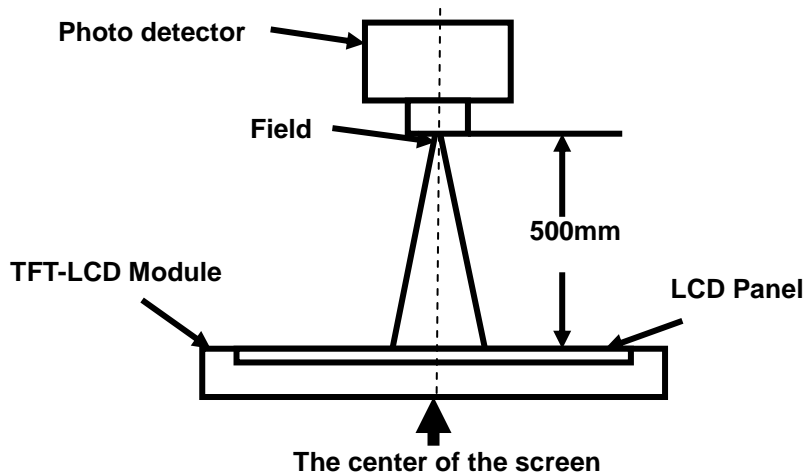

Note 2: Definition of viewing angle range and measurement system.

Viewing angle is measured at the center point of the LCD by LCD5200.

The 12 o'clock direction is upper side of outline in "8 Mechanical Drawing".

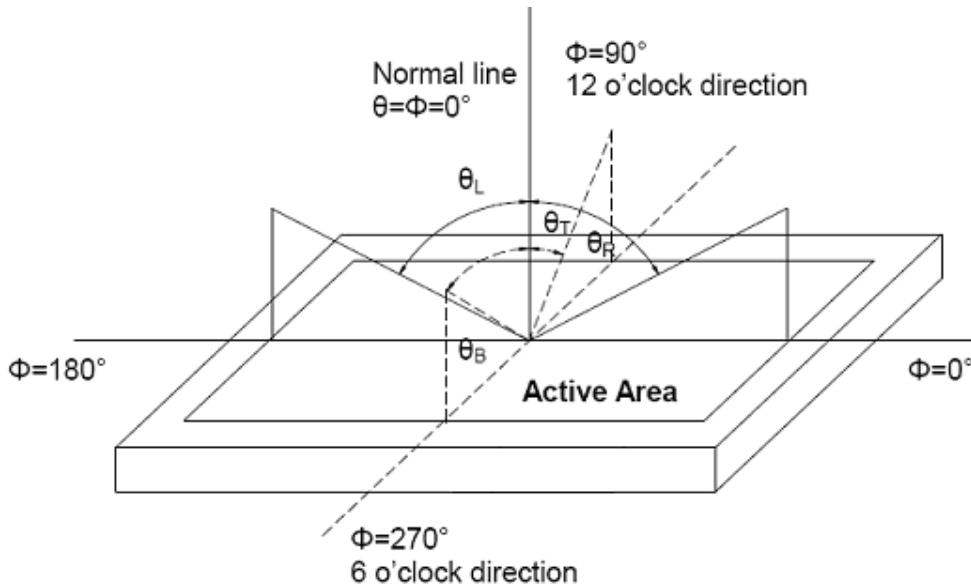

Fig. 1 Definition of viewing angle

Note 3: Definition of contrast ratio

The contrast ratio is calculated by using the following formula.

$$\text{Contrast ratio (CR)} = \frac{\text{Luminance of white screen}}{\text{Luminance of black screen}}$$

Note 4: Definition of Response time

The response time is defined as the LCD optical switching time interval between “Black” state and “White” state. Rise time (Ton) is the time between photo detector output intensity changed from 10% to 90%. And fall time (Toff) is the time between photo detector output intensity changed from 90% to 10%.

Product surface temperature: TopF= 29℃.

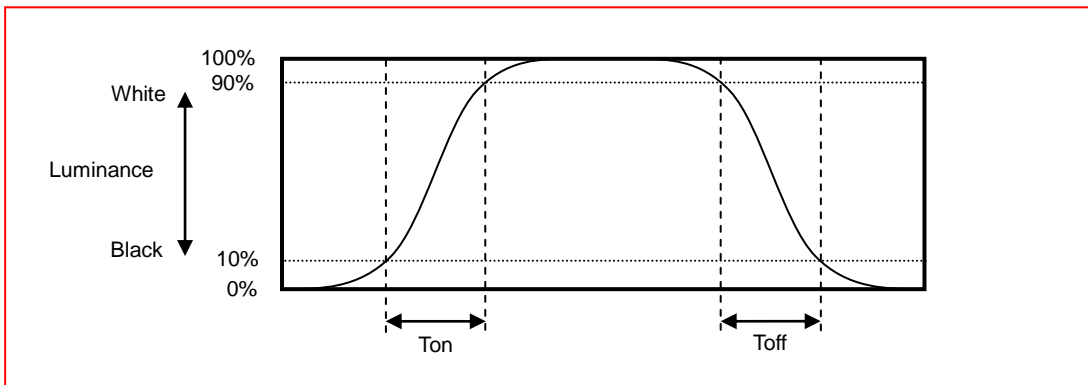

Note 5: Definition of color chromaticity (CIE1931)

Color coordinates measured at center point of LCD.

Note 6: Definition of Luminance Uniformity

The luminance uniformity is calculated by using following formula.

$$\text{Luminance uniformity (LU)} = \frac{\text{Minimum luminance from ① to ⑤}}{\text{Maximum luminance from ① to ⑤}}$$

The luminance is measured at near the 5 points shown below.

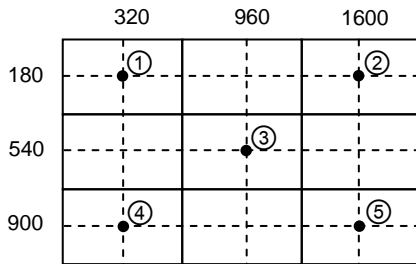

Fig. 2 Definition of uniformity

Note 7: Definition of Luminance :

Measure the luminance of white state at center point.

7 Environmental / Reliability Test

No	Test Item	Condition	Judgment Note1	
1	High Temperature Operation	①Ts = +70±3°C, 240 hours (Note1) ②Display data is white.	No display malfunctions	
2	Low Temperature Operation	Ts = -20±3°C, 240 hours (Note1)		
3	High Temperature & High Humidity Operation	①Ta = +60°C, 60% RH max, 240hours ②Display data is white.		
4	Thermal Shock (non-operation)	① -20 ± 3°C...30minutes +60 ± 3°C...30minutes ② 100cycles, 1hour/cycle ③ Temperature transition time is within 5 minutes.		
5	ESD(Operation)	① 150pF, R=150Ω, 10kV ② 9 places on a panel surface Note2 ③ 10 times each point at 1 sec interval		
6	Vibration (Non-operation)	① 5 to 100Hz, 11.76m/s ² ② 1 minute/cycle ③ X, Y, Z directions ④ 50 times each direction		No display malfunctions No physical damages
7	Shock (Non-operation)	① 294m/ s ² , 11ms ② ±X, ±Y, ±Z directions ③ 3 times each direction		

Note1: Display and appearance are checked under environmental conditions equivalent to the inspection conditions of defect criteria.

Note2: See the following figure for discharge points.

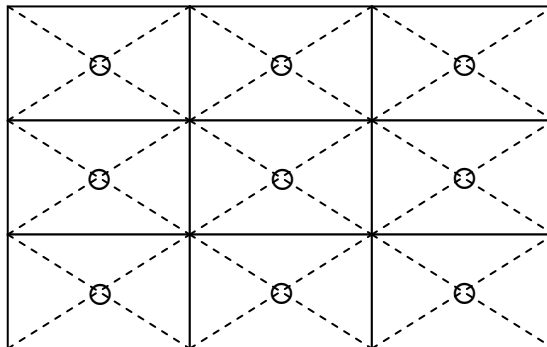

8 Mechanical Drawing

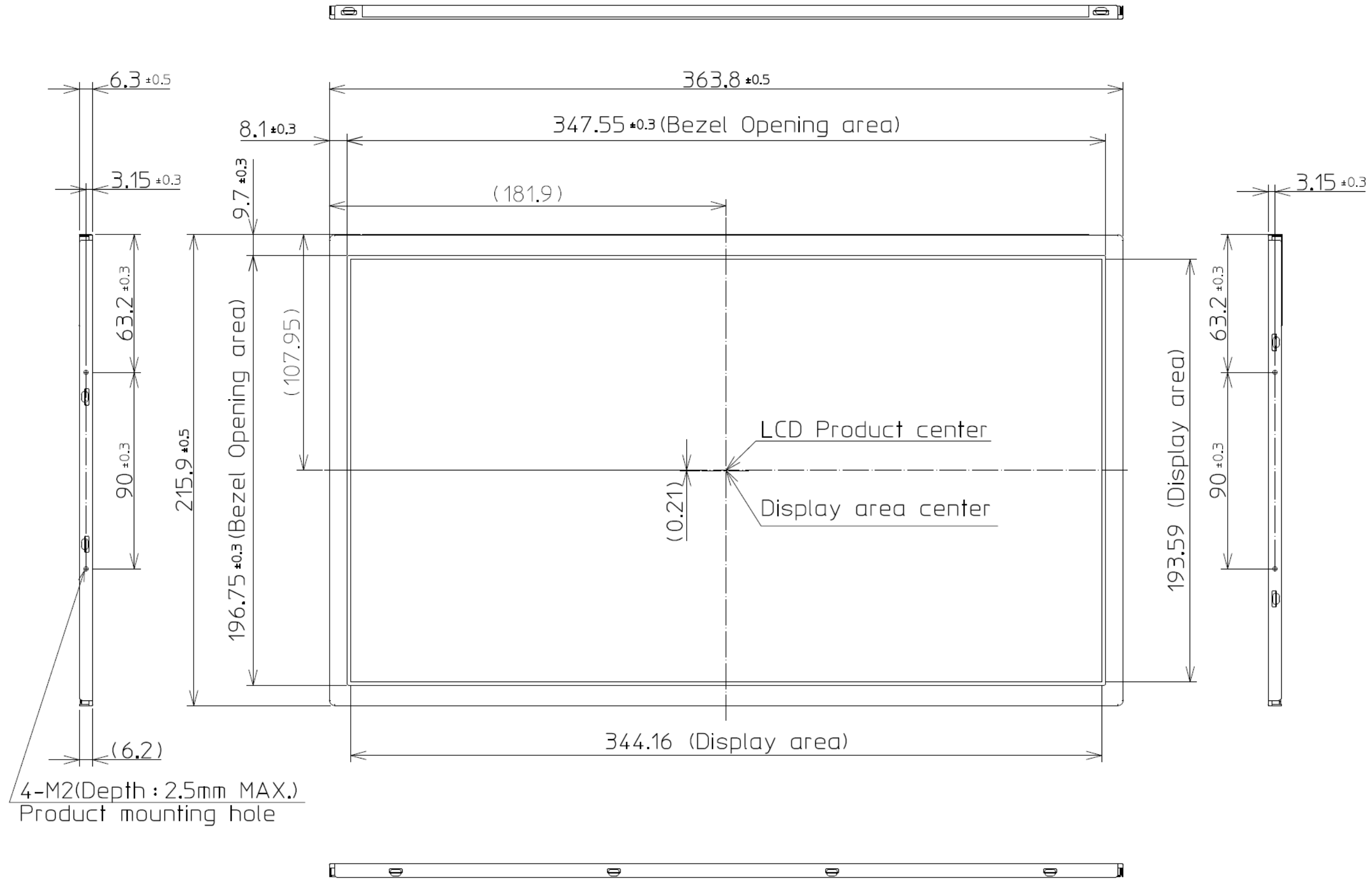

9 Packing Drawing

Parameter	Inner packing box	Unit
Size	394(W) × 520(H) × 524(D) (typ.)	mm
Weight	1.8 (typ.)	kg
Total weight	7.9(typ.) (with 10 products)	kg

10 Precautions For Use of LCD Modules

10.1 Handling Precautions

10.1.1 The display panel is made of glass. Do not subject it to a mechanical shock by dropping it from a high place, etc.

10.1.2 If the display panel is damaged and the liquid crystal substance inside it leaks out, be sure not to get any in your mouth, if the substance comes into contact with your skin or clothes, promptly wash it off using soap and water.

10.1.3 Do not apply excessive force to the display surface or the adjoining areas since this may cause the color tone to vary.

10.1.4 The polarizer covering the display surface of the LCD module is soft and easily scratched. Handle this polarizer carefully.

10.1.5 If the display surface is contaminated, breathe on the surface and gently wipe it with a soft dry cloth. If still not completely clear, moisten cloth with one of the following solvents:

- Isopropyl alcohol
- Ethyl alcohol

Solvents other than those mentioned above may damage the polarizer. Especially, do not use the following:

- Water
- Ketone
- Aromatic solvents

10.1.6 Do not attempt to disassemble the LCD Module.

10.1.7 If the logic circuit power is off, do not apply the input signals.

10.1.8 To prevent destruction of the elements by static electricity, be careful to maintain an optimum work environment.

10.1.8.1 Be sure to ground the body when handling the LCD Modules.

10.1.8.2 Tools required for assembly, such as soldering irons, must be properly ground.

10.1.8.3 To reduce the amount of static electricity generated, do not conduct assembly and other work under dry conditions.

10.1.8.4 The LCD Module is coated with a film to protect the display surface. Be care when peeling off this protective film since static electricity may be generated.

10.2 Storage Precautions

10.2.1 When storing the LCD modules, avoid exposure to direct sunlight or to the light of fluorescent lamps.

10.2.2 The LCD modules should be stored under the storage temperature range. If the LCD modules will be stored for a long time, the recommend condition is:

Temperature : 0°C ~ 40°C Relatively humidity: ≤80%

10.2.3 The LCD modules should be stored in the room without acid, alkali and harmful gas.

10.3 Transportation Precautions

The LCD modules should be no falling and violent shocking during transportation, and also should avoid excessive press, water, damp and sunshine.