



FS84/FS85C

Fail-safe system basis chip with multiple SMPS and LDO

Rev. 6 — 4 September 2020

Product brief



1 About this document

This Product brief is intended to provide overview/summary information for the purpose of evaluating a product for design suitability. It is intended for quick reference only and should not be relied upon to contain detailed and full information.

Some of the content in this product brief is extracted from the product's full data sheet. In case of any inconsistency or conflict, the full data sheet shall prevail.

For detailed and full information, see the relevant FS84_FS85 full data sheet, available via the NXP DocStore at <https://www.docstore.nxp.com>.

2 General description

The FS85/FS84 device family is developed in compliance with ASIL D process, FS84 is ASIL B capable and FS85 is ASIL D capable. All device options are pin to pin and software compatible.

The FS85/FS84 is an automotive functionally safe multi-output power supply integrated circuit, with focus on Radar, Vision, ADAS domain controller, Radio and Infotainment applications. It includes multiple switch mode and linear voltage regulators. It offers external frequency synchronization input and output, for optimized system EMC performance.

The FS85/FS84 includes enhanced safety features, with fail-safe output, becoming a full part of a safety-oriented system partitioning, covering both ASIL B and ASIL D safety integrity level. It is developed in compliance with ISO 26262 standard and is qualified in compliance with AEC-Q100 rev H (Grade1, MSL3).

Several device versions are available, offering choice in number of output rails, output voltage setting, operating frequency and power up sequencing, to address multiple applications.

3 Features and benefits

- 60 V DC maximum input voltage for 12 V and 24 V applications
- VPRE synchronous buck controller with external MOSFETs. Configurable output voltage, switching frequency, and current capability up to 10 A peak.
- Low voltage integrated synchronous BUCK1 converter, dedicated to MCU core supply with SVS capability. Configurable output voltage and current capability up to 3.6 A peak.
- **Based on device options (see Table 1):** low voltage integrated synchronous BUCK2 converter. Configurable output voltage and current capability up to 3.6 A peak. Multi-phase capability with BUCK1 to extend the current capability up to 7.2 A peak on a single rail. Static voltage scaling capability.



- **Based on device options (see Table 1):** low voltage integrated synchronous BUCK3 converter. Configurable output voltage and current capability up to 3.6 A peak.
- BOOST converter with integrated low-side switch. Configurable output voltage and max input current up to 1.5 A peak.
- EMC optimization techniques including SMPS frequency synchronization, spread spectrum, slew rate control, manual frequency tuning
- 2x linear voltage regulators for MCU IOs and ADC supply, external physical layer. Configurable output voltage and current capability up to 400 mA DC.
- OFF mode (power down) with very low quiescent current (10 μ A typ)
- 2x input pins for wake-up detection and battery voltage sensing
- Device control via 32 bits SPI or I2C interface with CRC
- Power synchronization pin to operate 2x FS85 devices or FS85 plus an external PMIC
- Scalable portfolio from ASIL B to ASIL D with independent monitoring circuitry, dedicated interface for MCU monitoring, simple and challenger watchdog function, power good, reset and interrupt, built-in self-test, fail-safe output
- Configuration by OTP programming. Prototype enablement to support custom setting during project development in engineering mode.

4 Applications

- Radar (corner radar, imaging radar, ...)
- Vision (mono camera, stereo camera, night vision, ...)
- ADAS domain controller
- Infotainment
- V2x

5 Ordering information

Table 1. Device options

Device options	BUCK1	BUCK2	BUCK3	FCCU	VMONx	ASIL
FS8400	Yes	No	No	No	up to 2	B
FS8405	Yes	No	No	optional	up to 4	B
FS8410	Yes	No	Yes	No	up to 2	B
FS8415	Yes	No	Yes	optional	up to 4	B
FS8420	Yes	Yes	No	No	up to 2	B
FS8425	Yes	Yes	No	optional	up to 4	B
FS8430	Yes	Yes	Yes	No	up to 2	B
FS8435	Yes	Yes	Yes	optional	up to 4	B
FS8500	Yes	No	No	Yes	up to 4	D
FS8510	Yes	No	Yes	Yes	up to 4	D
FS8520	Yes	Yes	No	Yes	up to 4	D
FS8530	Yes	Yes	Yes	Yes	up to 4	D

Table 2. Ordering information

Part number ^[1]	Application target	Package		
		Name	Description	Version
MC33FS8400G0ES	Superset covering FS8400 configurations	HPQFN56	HPQFN56, plastic, thermally enhanced very thin quad flat package, no lead, wettable flanks	SOT684-23
MC33FS8400G5ES	Camera			
MC33FS8405G0ES	Superset covering FS8405 configurations			
MC33FS8410G0ES	Superset covering FS8410 configurations			
MC33FS8410G3ES	Radar with NXP S32R274 MCU			
MC33FS8410G6ES	Gateway with NXP MPC5748G MCU			
MC33FS8415G0ES	Superset covering FS8415 configurations			
MC33FS8420G0ES	Superset covering FS8420 configurations			
MC33FS8425G0ES	Superset covering FS8425 configurations			
MC33FS8430G0ES	Superset covering FS8430 configurations			
MC33FS8430G1ES	Camera with NXP S32V MCU and PF8x PMIC			
MC33FS8430G2ES	Camera with NXP S32V MCU			
MC33FS8430G4ES	Camera			
MC33FS8435G0ES	Superset covering FS8435 configurations			
MC33FS8500A0ES	Superset covering FS8500 configurations			
MC33FS8510A0ES	Superset covering FS8510 configurations			
MC33FS8510A2ES	Domain controller			
MC33FS8510D3ES	Battery monitoring system			
MC33FS8520A0ES	Superset covering FS8520 configurations			
MC33FS8530A0ES	Superset covering FS8530 configurations			
MC33FS8530A1ES	Camera			
MC33FS8530A4ES	Imaging radar with NXP S32R MCU			

[1] To order parts in tape and reel, add the R2 suffix to the part number.

A0 and G0 parts are non-programmed OTP configurations. Pre-programmed OTP configurations (other than BUCK regulators and ASIL level) are managed through part number extension: A1 to FZ for FS85 and G1 to LZ for FS84.

For a custom OTP configuration, please contact you local NXP sales representative.

6 Simplified application diagram

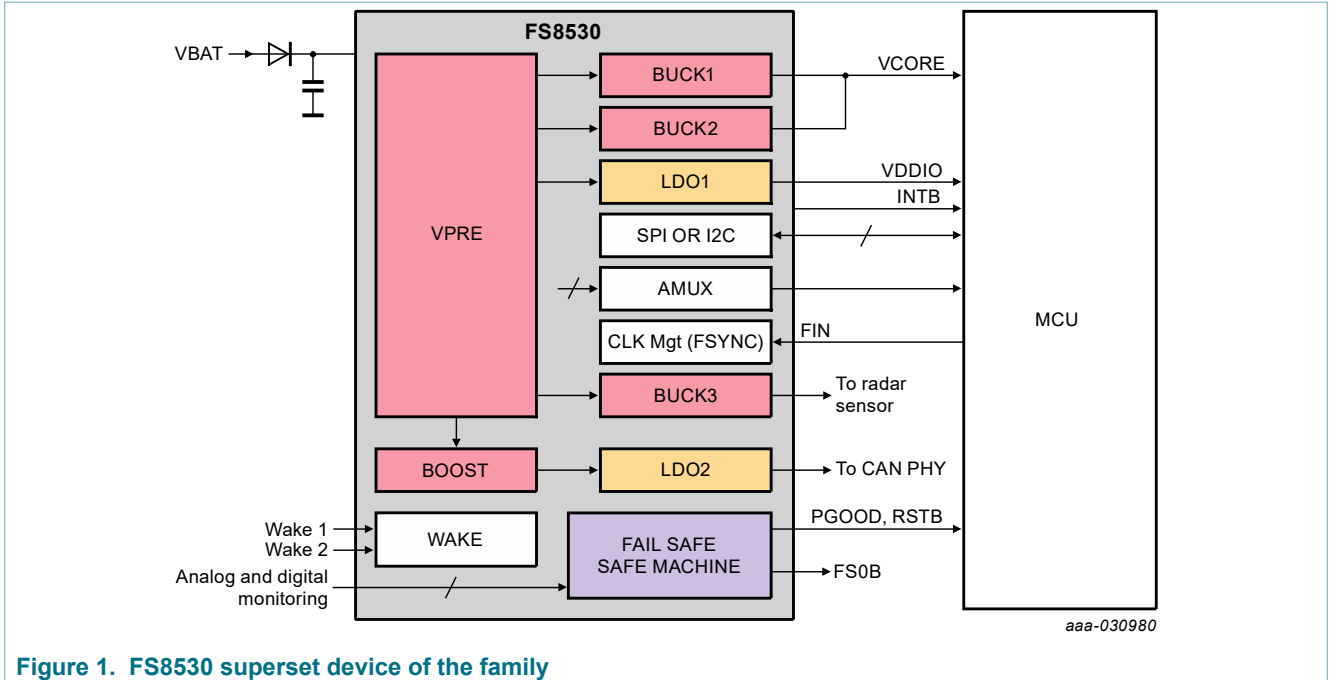

Figure 1. FS8530 superset device of the family

7 Pinning information

7.1 Pinning

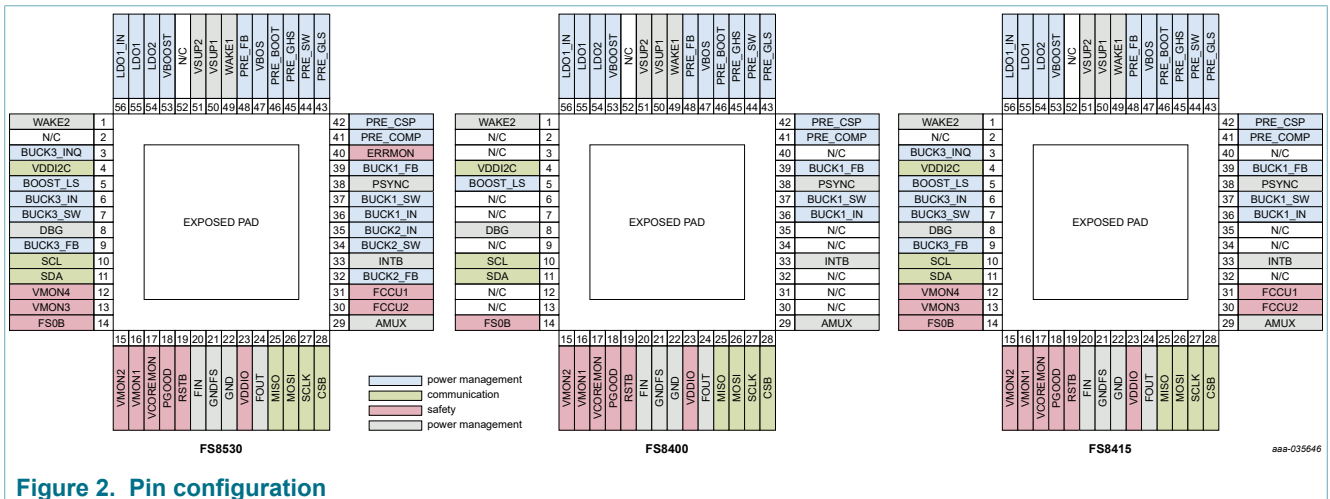

Figure 2. Pin configuration

7.2 Pin description

Table 3. Pin description

Symbol	Pin	Type	Description
WAKE2	1	A_IN / D_IN	Wake-up input 2 An external serial resistor is required if WAKE2 is a global pin

Symbol	Pin	Type	Description
N/C	2	N/C	Not connected pin
BUCK3_INQ	3	A_IN	Low voltage Buck3 quiet input voltage
VDDI2C	4	A_IN	Input voltage for I2C buffers
BOOST_LS	5	A_IN	Boost low-side drain of internal MOSFET
BUCK3_IN	6	A_IN	Low voltage Buck3 input voltage
BUCK3_SW	7	A_OUT	Low voltage Buck3 switching node
DBG	8	A_IN	Debug mode entry
BUCK3_FB	9	A_IN	Low voltage Buck3 voltage feedback
SCL	10	D_IN	I2C bus Clock input
SDA	11	D_IN/OUT	I2C bus Bidirectional data line
VMON4	12	A_IN	Voltage monitoring input 4
VMON3	13	A_IN	Voltage monitoring input 3
FS0B	14	D_OUT	Fail-safe output 0 Active low Open drain structure
VMON2	15	A_IN	Voltage monitoring input 2
VMON1	16	A_IN	Voltage monitoring input 1
VCOREMON	17	A_IN	VCORE monitoring input: Must be connected to Buck1 output voltage
PGOOD	18	D_OUT	Power good output Active low Pull up to VDDIO mandatory
RSTB	19	D_OUT	Reset output Active low The main function is to reset the MCU. Reset input voltage is monitored to detect external reset and fault condition. Pull up to VDDIO mandatory
FIN	20	D_IN	Frequency synchronization input
GNDFS	21	GND	Fail-safe ground
GND	22	GND	Main ground
VDDIO	23	A_IN	Input voltage for SPI, FOUT and AMUX buffers Allow voltage compatibility with MCU I/Os
FOUT	24	D_OUT	Frequency synchronization output
MISO	25	D_OUT	SPI bus Master input slave output
MOSI	26	D_IN	SPI bus Master output slave Input
SCLK	27	D_IN	SPI bus Clock input
CSB	28	D_IN	Chip select (active low)
AMUX	29	A_OUT	Multiplexed output to connect to MCU ADC Selection of the analog parameter through SPI or I2C
FCCU2	30	D_IN	MCU error monitoring input 2
FCCU1	31	D_IN	MCU error monitoring input 1

Symbol	Pin	Type	Description
BUCK2_FB	32	A_IN	Low voltage Buck2 voltage feedback
INTB	33	D_OUT	Interrupt output
BUCK2_SW	34	A_OUT	Low voltage Buck2 switching node
BUCK2_IN	35	A_IN	Low voltage Buck2 input voltage
BUCK1_IN	36	A_IN	Low voltage Buck1 input voltage
BUCK1_SW	37	A_OUT	Low voltage Buck1 switching node
PSYNC	38	D_IN/OUT	Power synchronization input/output
BUCK1_FB	39	A_IN	Low voltage Buck1 voltage feedback
ERRMON	40	D_IN	External IC error monitoring input
PRE_COMP	41	A_IN	VPRE compensation network
PRE_CSP	42	A_IN	VPRE positive current sense input
PRE_GLS	43	A_OUT	VPRE low-side gate driver for external MOSFET
PRE_SW	44	A_OUT	VPRE switching node
PRE_GHS	45	A_OUT	VPRE high-side gate driver for external MOSFET
PRE_BOOT	46	A_IN/OUT	VPRE bootstrap capacitor
VBOS	47	A_OUT	Best of supply output voltage
PRE_FB	48	A_IN	VPRE voltage feedback and negative current sense input
WAKE1	49	A_IN / D_IN	Wake up input 1 An external serial resistor is required if WAKE1 is a global pin
VSUP1	50	A_IN	Power supply 1 of the device An external reverse battery protection diode in series is mandatory
VSUP2	51	A_IN	Power supply 2 of the device An external reverse battery protection diode in series is mandatory
N/C	52	N/C	Not connected pin
VBOOST	53	A_IN	VBOOST voltage feedback
LDO2	54	A_OUT	Linear regulator 2 output voltage
LDO1	55	A_OUT	Linear regulator 1 output voltage
LDO1_IN	56	A_IN	Linear regulator 1 input voltage
EP	57	GND	Expose pad (BUCK1, BUCK2 and BUCK3 low-side GNDs are connected to the expose pad) Must be connected to GND

8 Maximum ratings

Table 4. Maximum ratings

All voltages are with respect to ground, unless otherwise noted. Exceeding these ratings may cause a malfunction or permanent damage to the device.

Symbol	Parameter	Conditions	Min	Max	Unit
Voltage ratings					
VSUP1/2	DC voltage	power supply VSUP1,2 pins	-0.3	60	V
WAKE1/2	DC voltage	WAKE1,2 pins; external serial resistor mandatory	-1.0	60	V
PRE_SW	DC voltage	PRE_SW pin	-2.0	60	V
	Transient voltage < 20 ns		-3.0	60	V
VMONx, FS0B	DC voltage	VMON1,2,3,4, VCOREMON, FS0B pins	-0.3	60	V
PRE_GHS, PRE_BOOT	DC voltage	PRE_GHS, PRE_BOOT pins	-0.3	65.5	V
DBG	DC voltage	DBG pin	-0.3	10	V
BOOST_LS	DC voltage	BOOST_LS pin	-0.3	8.5	V
VBOOST, LDO1_IN	DC voltage	VBOOST, LDO1_IN pins	-0.3	6.5	V
BUCKx_IN	DC voltage	BUCK1_IN, BUCK2_IN, BUCK3_IN, BUCK3_INQ	-1.0	5.5	V
BUCKx_IN	Transient voltage < 3 μ s	BUCK1_IN, BUCK2_IN, BUCK3_IN, BUCK3_INQ	-1.0	6.5	V
BUCKx_SW	Transient voltage < 20 ns	BUCK1_SW, BUCK2_SW, BUCK3_SW	-3.0	6.5	V
All other pins	DC voltage	at all other pins	-0.3	5.5	V
Current ratings					
I_WAKE	Maximum current capability	WAKE1,2	-5.0	5.0	mA
I_SUP	Maximum current capability	VSUP1,2	-5.0	—	mA

9 Electrostatic discharge

9.1 Human body model (JESD22/A114)

The device is protected up to ± 2 kV, according to the human body model at 100 pF and 1.5 k Ω . This protection is ensured at all pins.

9.2 Charged device model

The device is protected up to ± 500 V, according to the AEC Q100 - 011 charged device model standard. This protection is ensured at all pins.

9.3 Discharged contact test

The device is protected up to ± 8 kV, according to the following discharged contact tests.

Discharged contact test (IEC61000-4-2) at 150 pF and 330 Ω

Discharged contact test (ISO10605.2008) at 150 pF and 2 k Ω

Discharged contact test (ISO10605.2008) at 330 pF and 2 kΩ

This protection is ensured at VSUP1, VSUP2, WAKE1, WAKE2, FS0B pins.

10 Operating range

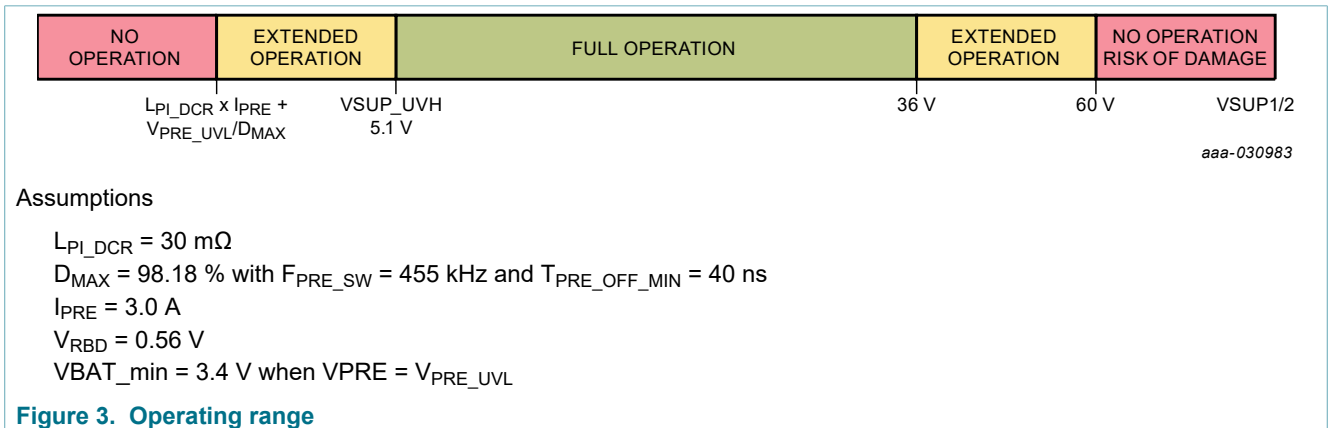

Figure 3. Operating range

- Below VSUP_UVH threshold, the extended operation range depends on VPRE output voltage configuration and external components.
 - When VPRE is configured at 5.0 V, VPRE may not remain in its regulation range.
 - VSUP minimum voltage depends on external components (LPI_DCR) and application conditions (IPRE, FPRE_SW).
- When VPRE is switching at 455 kHz, the FS85/FS84 maximum continuous operating voltage is 36 V. It has been validated at 48 V for limited duration of 15 minutes at room temperature to satisfy the jump start requirement of 24 V applications. It can sustain 58 V load dump without external protection.
- When VPRE is switching at 2.2 MHz, the FS85/FS84 maximum continuous operating voltage is 18 V. It will be validated at 26 V for limited duration of 2 minutes at room temperature to satisfy the jump start requirement of 12 V applications and 35 V load dump.

11 Thermal ratings

Table 5. Thermal ratings

Symbol	Parameter	Conditions	Min	Max	Unit
R _{θJA}	Thermal resistance junction to ambient	2s2p circuit board [1]	—	31	°C/W
R _{θJA}	Thermal resistance junction to ambient	2s6p circuit board [1]	—	23	°C/W
R _{θJB}	Thermal resistance junction to board	2s2p circuit board [1]	—	15	°C/W
R _{θJB}	Thermal resistance junction to board	2s6p circuit board [1]	—	10	°C/W
R _{θJC_BOT}	Thermal resistance junction to case bottom	between the die and the solder pad on the bottom of the package [1]	—	1	°C/W
R _{θJP_TOP}	Thermal resistance junction to package top	between package top and the junction temperature [1]	—	3	°C/W
T _A	Ambient temperature (Grade 1)		-40	125	°C

Symbol	Parameter	Conditions	Min	Max	Unit
T _J	Junction temperature (Grade 1)		-40	150	°C
T _{STG}	Storage temperature		-55	150	°C

[1] per JEDEC JESD51-2 and JESD51-8

12 Characteristics

Table 6. Electrical characteristics

T_A = -40 °C to 125 °C, unless otherwise specified. VSUP = VSUP_UVH to 36 V, unless otherwise specified. All voltages referenced to ground.

Symbol	Parameter	Min	Typ	Max	Unit
Power supply					
I _{SUP_NORMAL}	Current in Normal mode, all regulators ON (I _{OUT} = 0)	—	15	25	mA
I _{SUP_STANDBY}	Current in Standby mode, all regulators OFF except VBOS	—	5	10	mA
I _{SUP_OFF1}	Current in OFF mode (Power Down), T _A < 85 °C	—	10	15	μA
I _{SUP_OFF2}	Current in OFF mode (Power Down), T _A = 125 °C	—	—	25	μA
V _{SUP_UV7}	VSUP undervoltage threshold (7.0 V)	7.2	7.5	7.8	V
V _{SUP_UVH}	VSUP undervoltage threshold high (during power up and V _{sup} rising) OTP_VSUP_CFG = 0	4.7	—	5.1	V
	VSUP undervoltage threshold high (during power up and V _{sup} rising) OTP_VSUP_CFG = 1	6.0	—	6.4	V
V _{SUP_UVL}	VSUP undervoltage threshold low (during power up and V _{sup} falling) OTP_VSUP_CFG = 0	4.0	—	4.4	V
	VSUP undervoltage threshold low (during power up and V _{sup} falling) OTP_VSUP_CFG = 1	5.3	—	5.7	V
T _{SUP_UV}	V _{SUP_UV7} , V _{SUP_UVH} and V _{SUP_UVL} filtering time	6.0	10	15	μs

13 Package information

FS85/FS84 package is a QFN (sawn), thermally enhanced wettable flanks, 8 x 8 x 0.85 mm, 0.5 mm pitch, 56 pins.

13.1 Package outline

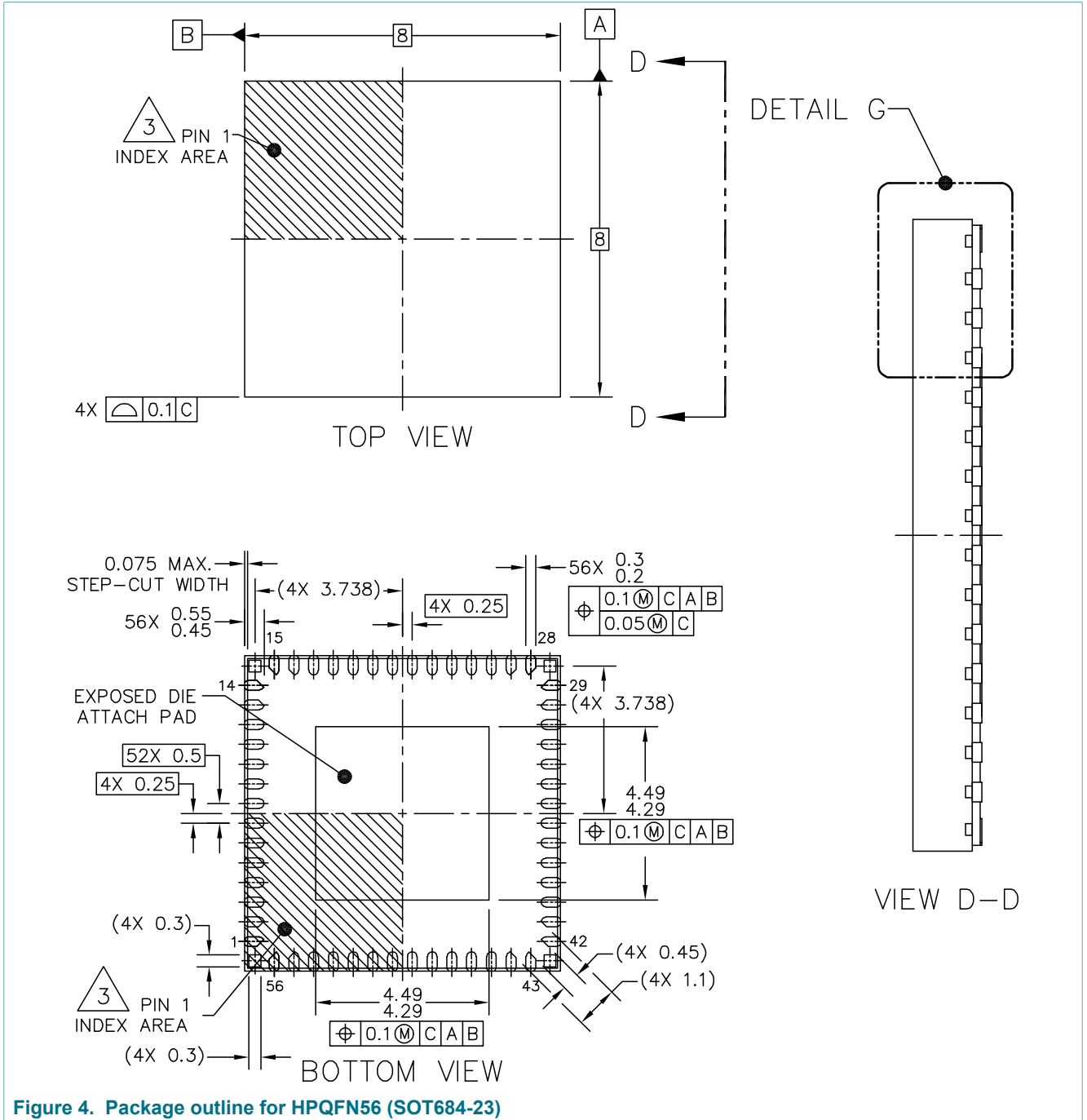

Figure 4. Package outline for HPQFN56 (SOT684-23)

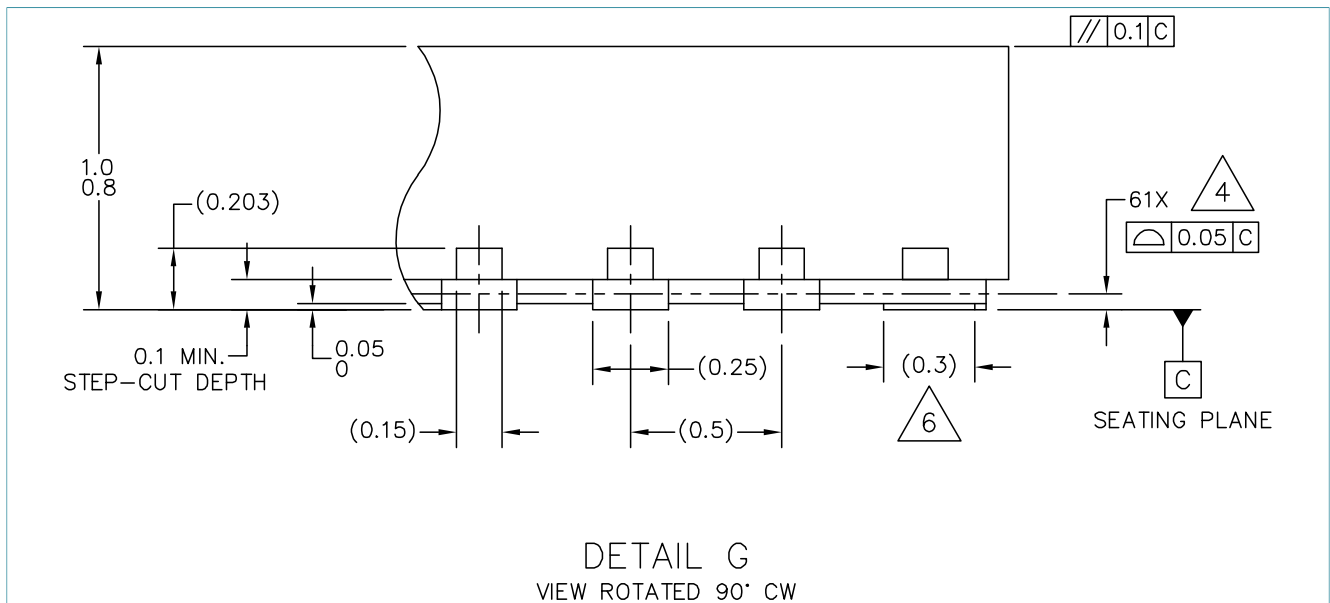

Figure 5. Package outline detail for HPQFN56 (SOT684-23)

NOTES:

1. ALL DIMENSIONS ARE IN MILLIMETERS.
2. DIMENSIONING AND TOLERANCING PER ASME Y14.5M-1994.
3. PIN 1 FEATURE SHAPE, SIZE AND LOCATION MAY VARY.
4. COPLANARITY APPLIES TO LEADS, DIE ATTACH FLAG AND CORNER NON-FUNCTIONAL PADS.
5. MIN. METAL GAP SHOULD BE 0.25 MM.
6. ANCHORING PADS.

Figure 6. Package outline notes for HPQFN56 (SOT684-23)

13.2 Landing pad information

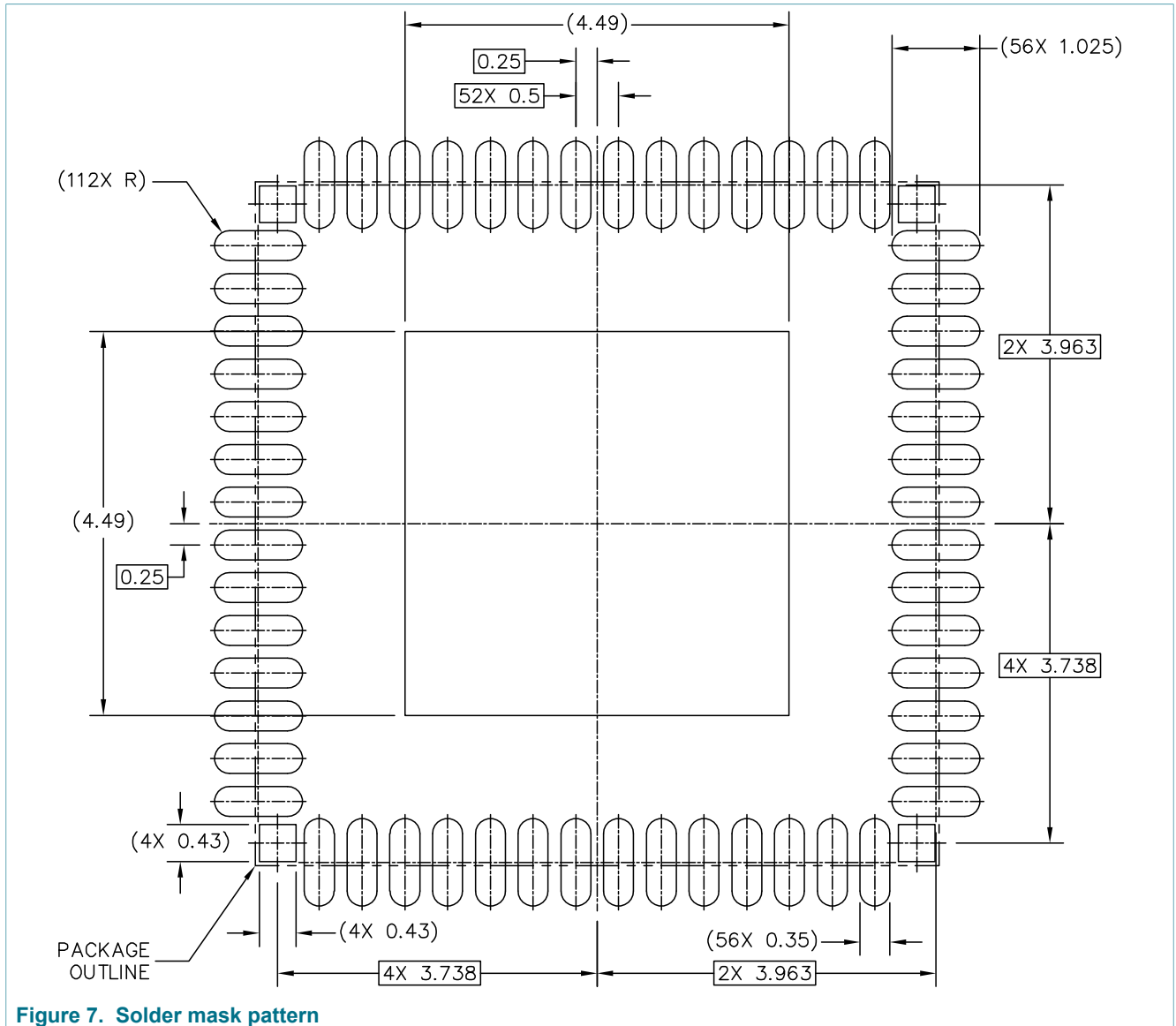

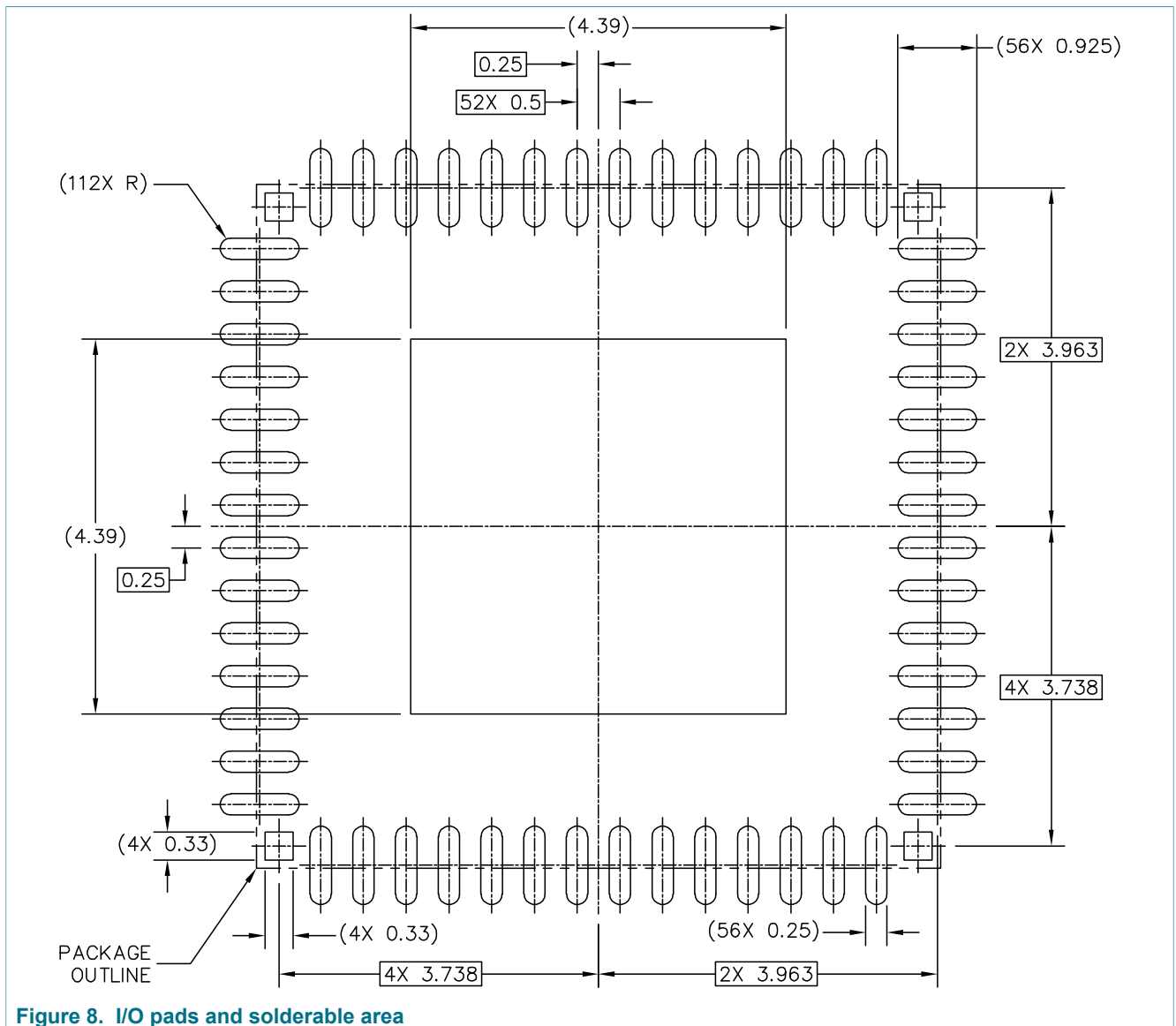

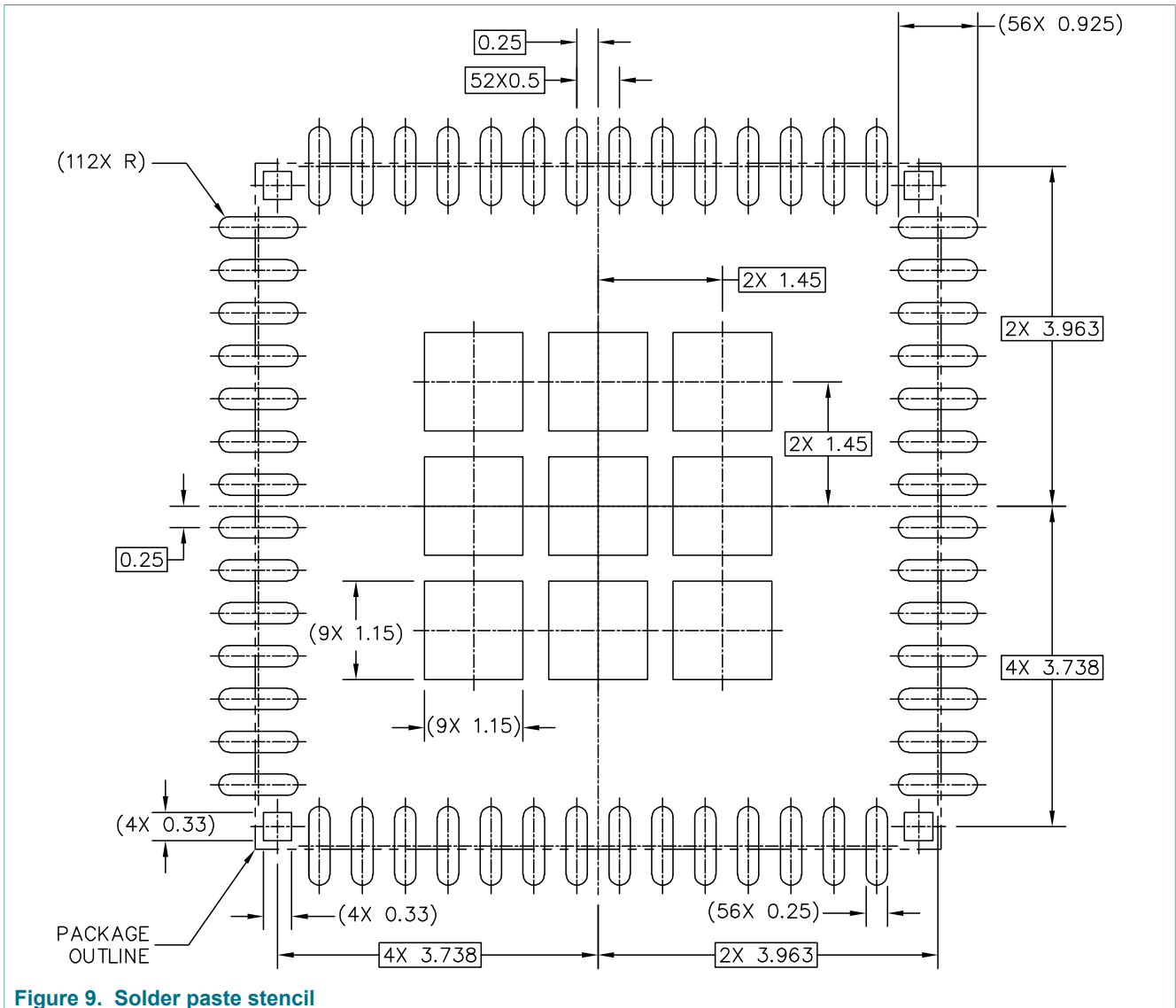

Figure 9. Solder paste stencil

14 References

- [1] **FS8400** — Safety System Basis Chip for S32 Microcontrollers, fit for ASIL B
<http://www.nxp.com/FS8400>
- [2] **FS8500** — Safety System Basis Chip for S32 Microcontroller, fit for ASIL D
<http://www.nxp.com/FS8500>
- [3] **FS85_PDTCALC** — VPRE compensation network calculation and power dissipation tool (Excel file)
<https://www.nxp.com/downloads/en/calculators/FS85-PDTCALC.xlsx>
- [4] **FS85_FMEDA** — FMEDA analysis ^[1]
- [5] **FS85_VPRE_Simplis_Model** Simplis model for stability and transient simulations ^[1]
- [6] **KITFS85FRDMEVM** — detailed information on this board, including documentation, downloads, and software and tools
<http://www.nxp.com/KITFS85FRDMEVM>

- [7] **KITFS85SKTEVM** — detailed information on this board, including documentation, downloads, and software and tools
<http://www.nxp.com/KITFS85SKTEVM>
- [8] **KITFS85AEEVM** — detailed information on this board, including documentation, downloads, and software and tools
<http://www.nxp.com/KITFS85AEEVM>
- [9] **AN12333** — FS84, FS85 product guidelines application note
https://www.nxp.com/webapp/sps/download/mod_download.jsp?colCode=AN12333
- [10] **FS85_FS84_OTP_Config.xlsm** — OTP configuration file
<https://www.nxp.com/webapp/Download?colCode=FS85-FS84-OTP>
- [11] **FS85_FS84SMUG** — Safety manual ^[1]
- [12] **ES_FS84_FS85** — Errata sheet
<https://www.nxp.com/webapp/Download?colCode=ES-FS84-FS85>

[1] Contact NXP sales representative.

15 Legal information

15.1 Definitions

Draft — The document is a draft version only. The content is still under internal review and subject to formal approval, which may result in modifications or additions. NXP Semiconductors does not give any representations or warranties as to the accuracy or completeness of information included herein and shall have no liability for the consequences of use of such information.

15.2 Disclaimers

Limited warranty and liability — Information in this document is believed to be accurate and reliable. However, NXP Semiconductors does not give any representations or warranties, expressed or implied, as to the accuracy or completeness of such information and shall have no liability for the consequences of use of such information. NXP Semiconductors takes no responsibility for the content in this document if provided by an information source outside of NXP Semiconductors. In no event shall NXP Semiconductors be liable for any indirect, incidental, punitive, special or consequential damages (including - without limitation - lost profits, lost savings, business interruption, costs related to the removal or replacement of any products or rework charges) whether or not such damages are based on tort (including negligence), warranty, breach of contract or any other legal theory. Notwithstanding any damages that customer might incur for any reason whatsoever, NXP Semiconductors' aggregate and cumulative liability towards customer for the products described herein shall be limited in accordance with the Terms and conditions of commercial sale of NXP Semiconductors.

Right to make changes — NXP Semiconductors reserves the right to make changes to information published in this document, including without limitation specifications and product descriptions, at any time and without notice. This document supersedes and replaces all information supplied prior to the publication hereof.

Applications — Applications that are described herein for any of these products are for illustrative purposes only. NXP Semiconductors makes no representation or warranty that such applications will be suitable for the specified use without further testing or modification. Customers are responsible for the design and operation of their applications and products using NXP Semiconductors products, and NXP Semiconductors accepts no liability for any assistance with applications or customer product design. It is customer's sole responsibility to determine whether the NXP Semiconductors product is suitable and fit for the customer's applications and products planned, as well as for the planned application and use of customer's third party customer(s). Customers should provide appropriate design and operating safeguards to minimize the risks associated with their applications and products. NXP Semiconductors does not accept any liability related to any default, damage, costs or problem which is based on any weakness or default in the customer's applications or products, or the application or use by customer's third party customer(s). Customer is responsible for doing all necessary testing for the customer's applications and products using NXP Semiconductors products in order to avoid a

default of the applications and the products or of the application or use by customer's third party customer(s). NXP does not accept any liability in this respect.

Limiting values — Stress above one or more limiting values (as defined in the Absolute Maximum Ratings System of IEC 60134) will cause permanent damage to the device. Limiting values are stress ratings only and (proper) operation of the device at these or any other conditions above those given in the Recommended operating conditions section (if present) or the Characteristics sections of this document is not warranted. Constant or repeated exposure to limiting values will permanently and irreversibly affect the quality and reliability of the device.

Terms and conditions of commercial sale — NXP Semiconductors products are sold subject to the general terms and conditions of commercial sale, as published at <http://www.nxp.com/profile/terms>, unless otherwise agreed in a valid written individual agreement. In case an individual agreement is concluded only the terms and conditions of the respective agreement shall apply. NXP Semiconductors hereby expressly objects to applying the customer's general terms and conditions with regard to the purchase of NXP Semiconductors products by customer.

No offer to sell or license — Nothing in this document may be interpreted or construed as an offer to sell products that is open for acceptance or the grant, conveyance or implication of any license under any copyrights, patents or other industrial or intellectual property rights.

Suitability for use in automotive applications — This NXP Semiconductors product has been qualified for use in automotive applications. Unless otherwise agreed in writing, the product is not designed, authorized or warranted to be suitable for use in life support, life-critical or safety-critical systems or equipment, nor in applications where failure or malfunction of an NXP Semiconductors product can reasonably be expected to result in personal injury, death or severe property or environmental damage. NXP Semiconductors and its suppliers accept no liability for inclusion and/or use of NXP Semiconductors products in such equipment or applications and therefore such inclusion and/or use is at the customer's own risk.

Export control — This document as well as the item(s) described herein may be subject to export control regulations. Export might require a prior authorization from competent authorities.

Translations — A non-English (translated) version of a document is for reference only. The English version shall prevail in case of any discrepancy between the translated and English versions.

15.3 Trademarks

Notice: All referenced brands, product names, service names and trademarks are the property of their respective owners.

NXP — is a trademark of NXP B.V.

SafeAssure — is a trademark of NXP B.V.

Tables

Tab. 1.	Device options	2	Tab. 4.	Maximum ratings	7
Tab. 2.	Ordering information	3	Tab. 5.	Thermal ratings	8
Tab. 3.	Pin description	4	Tab. 6.	Electrical characteristics	9

Figures

Fig. 1.	FS8530 superset device of the family	4	Fig. 6.	Package outline notes for HPQFN56 (SOT684-23)	11
Fig. 2.	Pin configuration	4	Fig. 7.	Solder mask pattern	12
Fig. 3.	Operating range	8	Fig. 8.	I/O pads and solderable area	13
Fig. 4.	Package outline for HPQFN56 (SOT684-23) ...	10	Fig. 9.	Solder paste stencil	14
Fig. 5.	Package outline detail for HPQFN56 (SOT684-23)	11			

Contents

1	About this document	1
2	General description	1
3	Features and benefits	1
4	Applications	2
5	Ordering information	2
6	Simplified application diagram	4
7	Pinning information	4
7.1	Pinning	4
7.2	Pin description	4
8	Maximum ratings	7
9	Electrostatic discharge	7
9.1	Human body model (JEDEC22/A114)	7
9.2	Charged device model	7
9.3	Discharged contact test	7
10	Operating range	8
11	Thermal ratings	8
12	Characteristics	9
13	Package information	9
13.1	Package outline	10
13.2	Landing pad information	12
14	References	14
15	Legal information	16

Please be aware that important notices concerning this document and the product(s) described herein, have been included in section 'Legal information'.

© NXP B.V. 2020.

All rights reserved.

For more information, please visit: <http://www.nxp.com>

For sales office addresses, please send an email to: salesaddresses@nxp.com

Date of release: 4 September 2020
Document identifier: PB_FS84_FS85C