

Product Specification

SPECIFICATION FOR APPROVAL

 Preliminary Specification

 Final Specification

Title	23.8" UHD TFT LCD
-------	-------------------

BUYER	General
MODEL	

SUPPLIER	LG Display Co., Ltd.
*MODEL	LM238WR2
SUFFIX	SPE1

*When you obtain standard approval,
please use the above model name without suffix

APPROVED BY	SIGNATURE DATE
/	
/	
/	

Please return 1 copy for your confirmation with your signature and comments.

APPROVED BY	SIGNATURE DATE
REVIEWED BY	
PREPARED BY	

Product Engineering Dept.
LG Display Co., Ltd

Product Specification
APPENDIX
Contents

No	ITEM	Page
	COVER	1
	CONTENTS	2
	RECORD OF REVISIONS	3
1	GENERAL DESCRIPTION	4
2	ABSOLUTE MAXIMUM RATINGS	5
3	ELECTRICAL SPECIFICATIONS	6
3-1	ELECTRICAL CHARACTERISTICS	6
3-2	INTERFACE CONNECTIONS	9
3-3	eDP SIGNAL SPECIFICATIONS	11
3-4	SIGNAL TIMING SPECIFICATIONS	15
3-5	SIGNAL TIMING WAVEFORMS	16
3-6	COLOR INPUT DATA REFERENCE	17
3-7	POWER SEQUENCE & DIP CONDITION FOR LCD MODULE	18
4	OPTICAL SPECIFICATIONS	20
5	MECHANICAL CHARACTERISTICS	24
6	RELIABILITY	27
7	INTERNATIONAL STANDARDS	28
7-1	SAFETY	28
7-2	ENVIRONMENT	28
8	PACKING	29
8-1	DESIGNATION OF LOT MARK	29
8-2	PACKING FORM	30
9	PRECAUTIONS	31
	# APPENDIX (Serial / Box / Pallet Label)	33

Product Specification

RECORD OF REVISIONS

Revision No	Revision Date	Page	Before	After	Application Date
1.0	Jan., 21,2019	-	First Draft, Final Specifications		

Product Specification

1. General Description

LM238WR2 is a Color Active Matrix Liquid Crystal Display with a Light Emitting Diode (LED) backlight system without LED driver. The matrix employs a-Si Thin Film Transistor as the active element. It is a transmissive type display operating in the normally black mode. It has a 23.8 inch diagonally measured active display area with UHD resolution (3840 horizontal by 2160 vertical pixel array) Each pixel is divided into Red, Green and Blue sub-pixels or dots which are arranged in vertical stripes. Gray scale or the brightness of the sub-pixel color is determined with a 10-bit gray scale signal for each dot, thus, presenting a palette of more than 1.07Billion colors with A-FRC (Advanced Frame Rate Control).

It has been designed to apply eDP(HBR2, 5.4Gbps) interface.

It is intended to support displays where high brightness, super wide viewing angle, high color saturation, and high color are important.

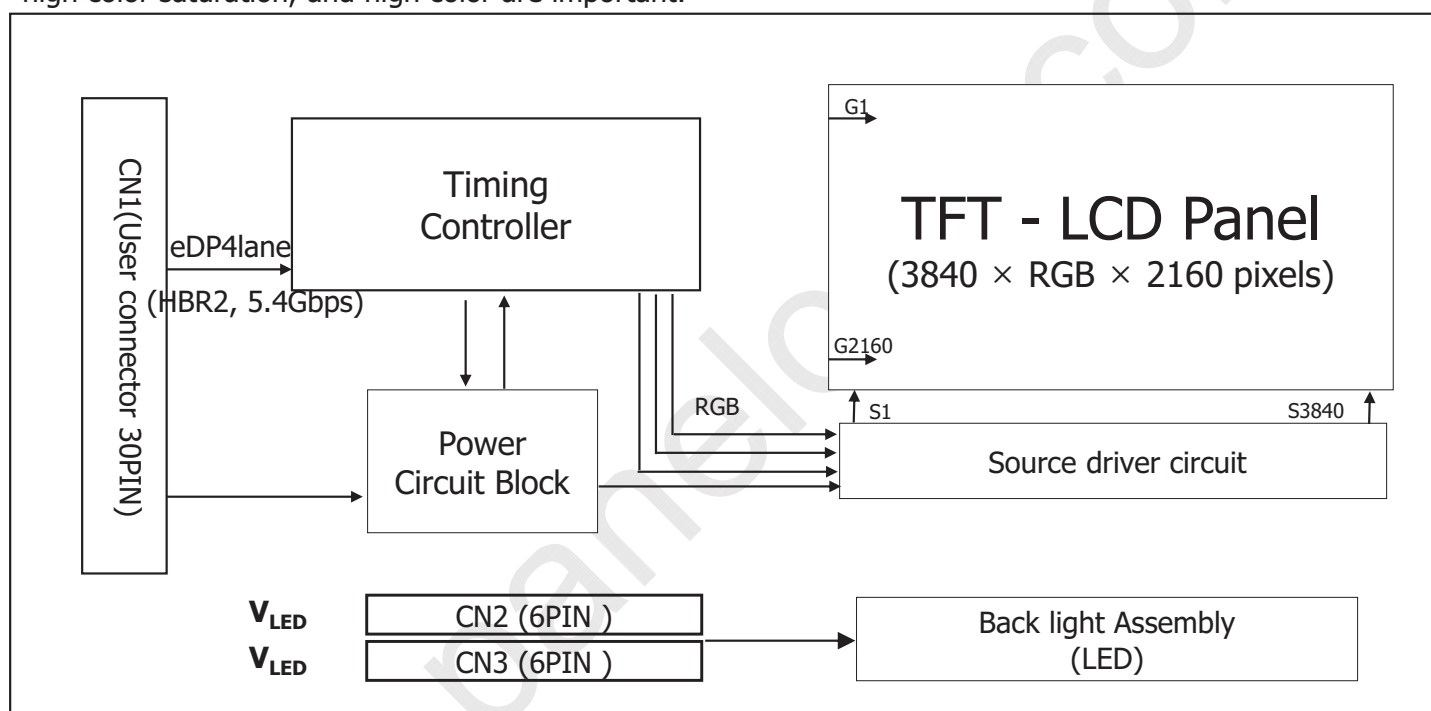

[FIG.1] Block diagram

General Features

Active Screen Size	23.74 inches(60.31cm) diagonal
Outline Dimension	544.7(H) x 323.2(V) x 13.8(D) mm (Typ.)
Pixel Pitch	0.1369 mm x 0.1369 mm
Pixel Format	3840 horiz. By 2160 vert. Pixels RGB stripes arrangement
Color Depth	1.07 Billion colors, 10Bit (8Bit + A-FRC)
Luminance, White	540 cd/m ² (Center 1 Point, Typ.)
Viewing Angle(CR>10)	View Angle Free (R/L 178(Typ.), U/D 178(Typ.))
Power Consumption	Total 38.7 Watt (Typ.) (6.3 Watt @V _{LCD} , 32.4 Watt @I _s =100mA)
Weight	2,190g (Typ.)
Display Operating Mode	Transmissive mode, normally black
Panel type	Reverse type
Surface Treatment	Low-Reflective treatment of the front polarizer (2H)

Product Specification

2. Absolute Maximum Ratings

The following are maximum values which, if exceeded, may cause faulty operation or damage to the unit.

Table 1. ABSOLUTE MAXIMUM RATINGS

Parameter	Symbol	Values		Units	Notes
		Min	Max		
Power Supply Input Voltage	V_{LCD}	-0.3	12.0	V_{DC}	At 25 °C
Operating Temperature	T_{OP}	0	50	°C	1,2,3
Storage Temperature	T_{ST}	-20	60	°C	
Operating Ambient Humidity	H_{OP}	10	90	%RH	
Storage Humidity	H_{ST}	10	90	%RH	
LCM Surface Temperature (Operation)	$T_{Surface}$	0	65	°C	1, 4

Notes :

- Temperature and relative humidity range are shown in the figure below.
Wet bulb temperature should be 39 °C Max., and no condensation of water.
- Maximum storage humidity is up to 40 °C, 70% RH only for 4 corner light leakage mura.
- Storage condition is guaranteed under packing condition
- LCM surface temperature should be measured under the condition of $V_{LCD}=10.0V$, $f_v=60Hz$, $T_a=25\text{ °C}$, no humidity and typical LED string current.
※. T_a = Ambient temperature

FIG. 2 Temperature and relative humidity

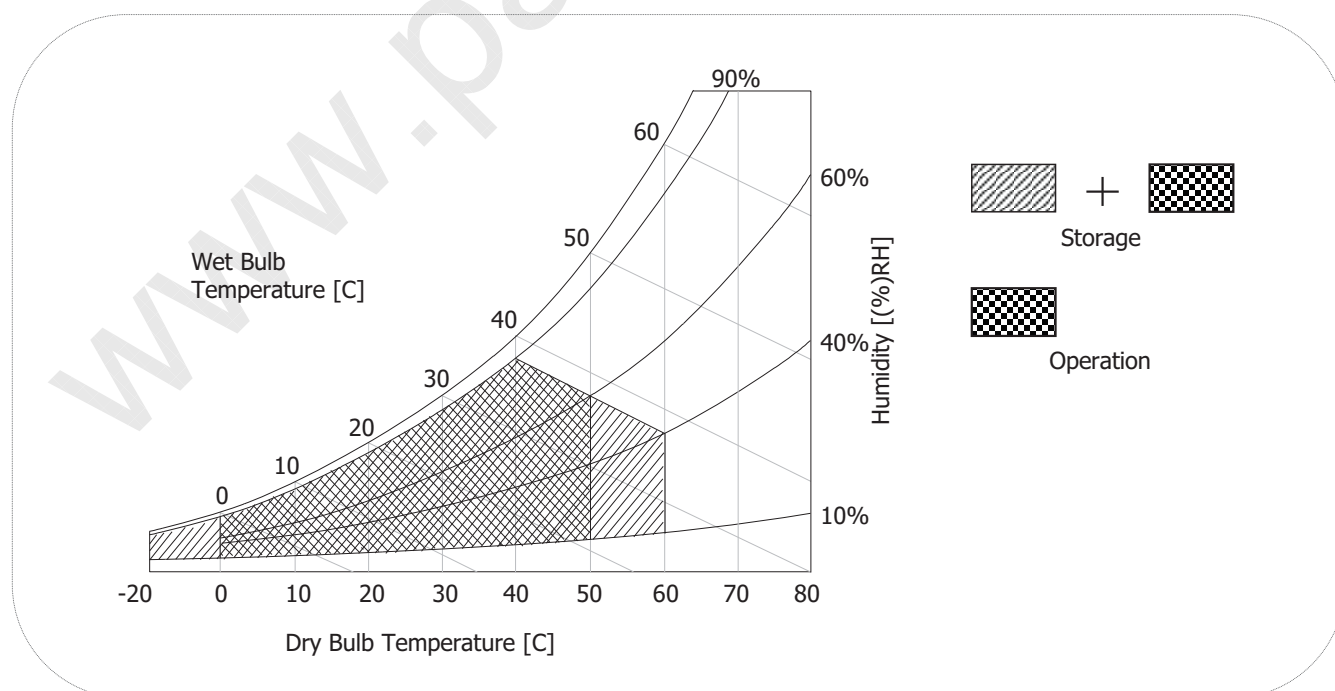

Product Specification

3. Electrical Specifications

3-1. Electrical Characteristics

It requires two power inputs. One is employed to power the LCD electronics and to drive the TFT array and liquid crystal. The other input power for the LED/Backlight, is typically generated by a LED Driver. The LED Driver is an external unit to the LCDs.

Table 2-1. ELECTRICAL CHARACTERISTICS

Parameter	Symbol	Values			Unit	Notes
		Min	Typ	Max		
MODULE :						
Power Supply Input Voltage	V _{LCD}	9.5	10.0	10.5	V _{dc}	5
Permissive Power Input Ripple	V _{dRF}			400	mV _{p-p}	1
Power Supply Input Current	I _{LCD}	-	630	788	mA	2
		-	840	1050	mA	3
Power Consumption	P _c TYP	-	6.3	7.88	Watt	2
	P _c MAX	-	8.4	10.5	Watt	3
Rush current	I _{RUSH}	-		3	A	4

Note :

- Permissive power ripple should be measured under the condition of V_{LCD}=10.0V, 25°C,* f_v=60Hz
Refer to page 7 for the pattern and more information.
- The specified current and power consumption can be measured under the V_{LCD}=10.0V, 25°C, f_v=60Hz and the pattern should be changed according to the typical or maximum power condition.
The Max current can be measured only with the maximum power pattern.
See the page 7 for details.
- Maximum Condition of Inrush current :
The duration of rush current is about 5ms and rising time of power Input is 500us ± 20%. (min.)
- V_{LCD} level must be measured between two points on PCB of LCM (V_{LCD} (test point) ~ LCM Ground)
(Test condition : maximum power pattern, 25°C, f_v=60Hz)

*f_v=frame frequency

Product Specification

- **Permissive Power input ripple** ($V_{LCD} = 10.0V$, $25^{\circ}C$, f_v (frame frequency)=MAX condition)

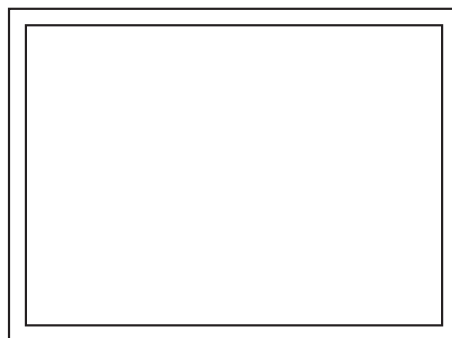
**White pattern**

For the exact ripple measurement, the condition of Max 20Mhz is recommended in the Bandwidth configuration of oscilloscope.

- **Power consumption** ($V_{LCD} = 10V$, $25^{\circ}C$, f_v (frame frequency)=60Hz condition)

**Typical power Pattern****Maximum power Pattern**

FIG. 3 Mosaic pattern & White Pattern for power consumption measurement

Product Specification
Table 2-2. ELECTRICAL CHARACTERISTICS of LED bar in normal operating condition

Parameter	Symbol	Values			Unit	Notes
		Min.	Typ.	Max.		
LED String Current	Is	-	100	105	mA	1, 2
LED String Voltage	Vs	37.7	40.5	43.3	V	1, 3
Power Consumption	PBar	-	32.4	34.6	Watt	1, 2, 5
LED Life Time	LED_LT	30,000	-	-	Hrs	4

Notes) The LED Bar consists of 56ea LED packages, 4 strings (parallel) x 14 packages (serial) x 2 bar

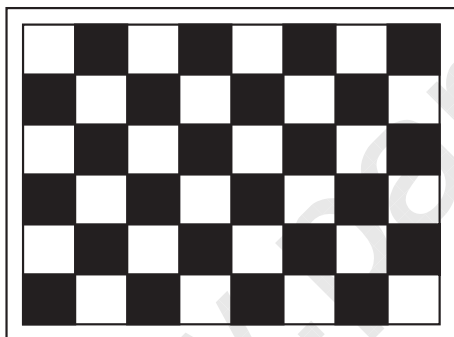
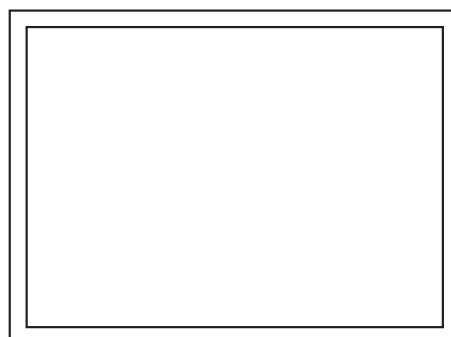
1. The specified values are for single LED bar.
2. The specified current is defined as the input current for single LED string with 100% duty cycle.
3. The specified voltage is the input LED string voltage at typical current 100% duty cycle.
4. The LED life time is defined as the time when brightness of LED itself reach to the 50% of initial value under the conditions at $T_a = 25 \pm 2^\circ\text{C}$ and typical LED string current.
5. The power consumption shown above does not include the loss of external LED driver.
 The typical power consumption is calculated as $P_{\text{Bar}} = V_s(\text{Typ.}) \times I_s(\text{Typ.}) \times \text{No. of strings}$.
 The maximum power consumption is calculated as $P_{\text{Bar}} = V_s(\text{Max.}) \times I_s(\text{Typ.}) \times \text{No. of strings}$.

Product Specification

3-2. Interface Connections

3-2-1. LCD Module

- LCD Connector(CN1) : GT05Q-30S-H10-MN (LSMtron), HD2S030HA2 (JAE), KN38B-30S-0.5H(HIROSE) or Equivalent
- Mating Connector : 20453-030T-## (Manufactured by I-PEX) or Equivalent

Table 3. MODULE CONNECTOR(CN1) PIN CONFIGURATION

No	Symbol	Description	No	Symbol	Description
1	VLCD	Power Supply +10.0V	16	Lane0P	True Signal for Main Link 0
2	VLCD	Power Supply +10.0V	17	Lane0N	Component Signal for Main Link 0
3	VLCD	Power Supply +10.0V	18	GND	Ground
4	VLCD	Power Supply +10.0V	19	Lane1P	True Signal for Main Link 1
5	VLCD	Power Supply +10.0V	20	Lane1N	Component Signal for Main Link 1
6	NC	No connection	21	GND	Ground
7	GND	Ground	22	Lane2P	True Signal for Main Link 2
8	NC	No Connection(I2C serial interface for LCM)	23	Lane2N	Component Signal for Main Link 2
9	NC	No Connection(I2C serial interface for LCM)	24	GND	Ground
10	GND	Ground	25	Lane3P	True Signal for Main Link 3
11	HPD	Hot Plug Detect Signal	26	Lane3N	Component Signal for Main Link 3
12	GND	Ground	27	GND	Ground
13	AUX_CHN	Component Signal for Auxiliary Channel	28	GND	Ground
14	AUX_CHP	True Signal for Auxiliary Channel	29	BL_EN	Enable signal for Backlight
15	GND	Ground	30	GND	Ground

- Note: 1. All GND(ground) pins should be connected together and to Vss which should also be connected to the LCD's metal frame.
 2. All VLCD (power input) pins should be connected together.
 3. BL_EN (Enable signal for backlight) : If you don't use this pin, it should be NC (No connection).

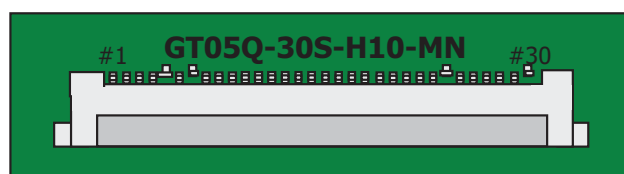

Rear view of LCM

FIG.4 Connector diagram

Product Specification
3-2-2. BACKLIGHT CONNECTOR PIN CONFIGURATION(CN2,3)

The LED interface connector is a model 10035WS-H06D(HF) Manufactured by Yeonho or equivalent.
 The mating connector is a SHJP-06V-S(HF), 10035HS-H06C(HF) or equivalent.
 The pin configuration for the connector is shown in the table below.

Table 3-1. LED CONNECTOR PIN CONFIGURATION (CN2,3)

Pin	Symbol	Pin-description (CN2)	Remark	Pin	Symbol	Pin-description (CN3)	Remark
#1	FB1	Channel 1 current feedback	Upper LED Bar	#1	FB1	Channel 1 current feedback	Bottom LED Bar
#2	FB2	Channel 2 current feedback		#2	FB2	Channel 2 current feedback	
#3	V LED	LED power supply (common anode)		#3	V LED	LED power supply (common anode)	
#4	V LED	LED power supply (common anode)		#4	V LED	LED power supply (common anode)	
#5	FB3	Channel 3 current feedback		#5	FB3	Channel 3 current feedback	
#6	FB4	Channel 4 current feedback		#6	FB4	Channel 4 current feedback	

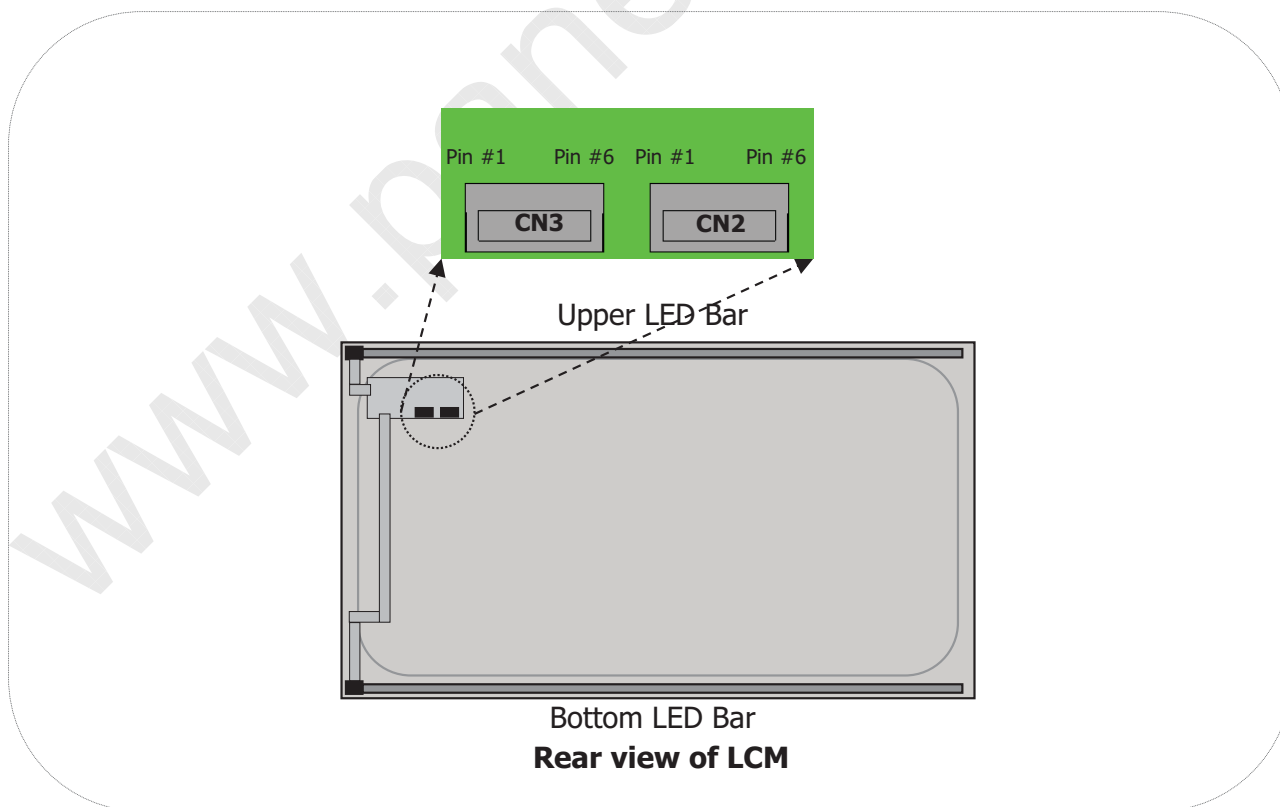
[FIG. 5] Backlight connector view

Product Specification

3-3. eDP Signal Specifications

3-3-1. eDP Main Link Signal

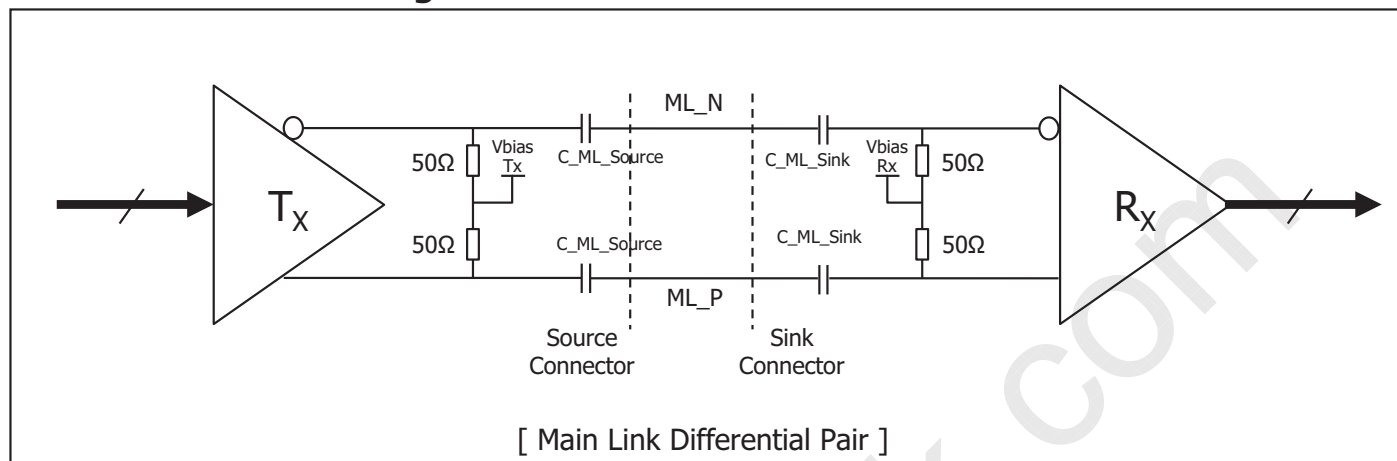

Parameter	Symbol	Min	Typ	Max	Unit	Notes
Unit Interval for high bit rate (5.4Gbps / lane)	UI_HBR2	-	185	-	ps	
Link Clock Down Spreading	Amplitude	0	-	0.5	%	
	Frequency	30		33	kHz	
Maximum output voltage level at Source side connector	$V_{TX-DIFFp-p-Max}$	-	-	1.38	V	Note 6)
Differential peak-to-peak voltage at Sink side connector	$V_{RX-DIFFp-p}$	0.09	-	-	V	Note 7)
EYE width at Sink side connector	$T_{RX-EYE-CONN}$	0.38	-	-	UI	Note 6,7)
Lane intra-pair skew	$L_{RX-SKEW-INTRA_PAIR}$	-	-	50	ps	
AC Coupling Capacitor	$C_{SOURCE-ML}$	75		200	nF	Source side

Note)

1. Termination resistor is typically integrated into the transmitter and receiver implementations.
2. In cabled embedded system, it is recommended the system designer ensure that EYE width and voltage are met at the sink side connector pins.
3. Mismatched common mode voltage will occur abnormal display.
4. All eDP electrical spec is measured at sink connector side.
5. eDP cable Impedance should be $100\text{ohm} \pm 5\%$.

Product Specification

Note6) Definition of Differential Voltage

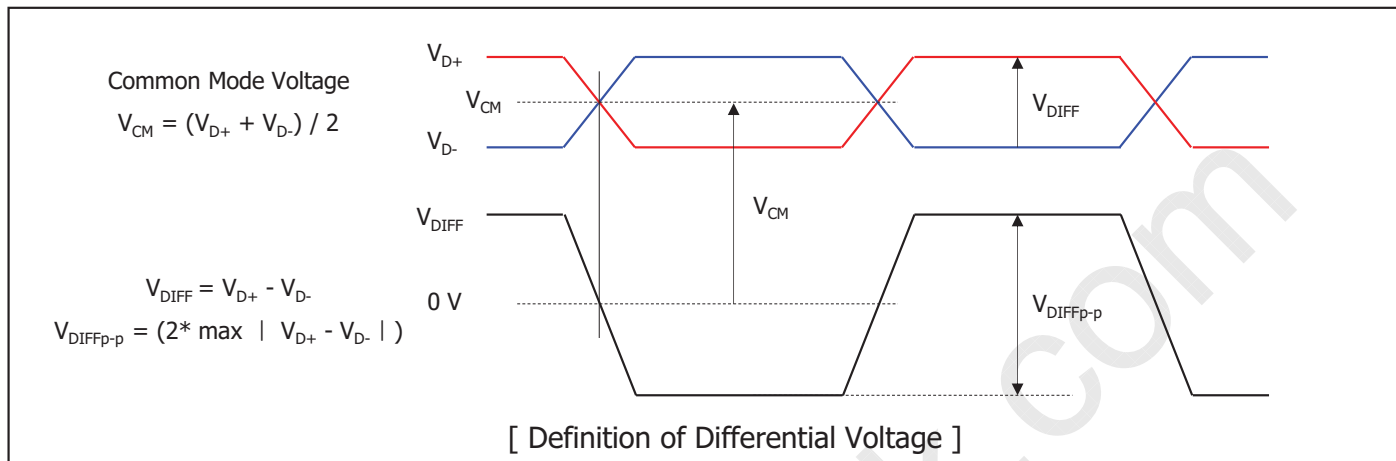

Note7) Main Link EYE Diagram

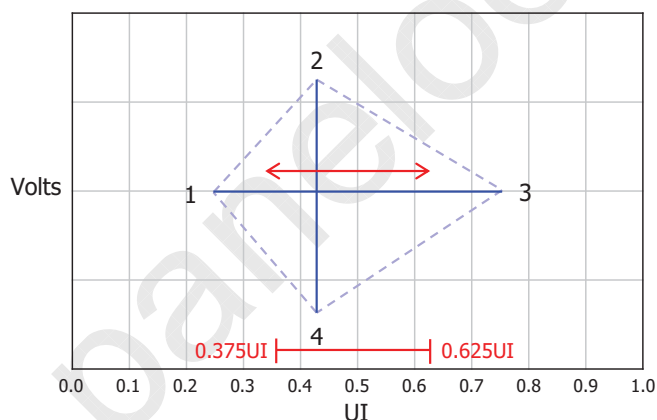

Point	High Bit Rate 2 @ TP3 EQ	
	Time(UI)	Voltage(V)
1	Any UI location (x) where the eye width is open from x to x+0.38UI	0.000
2	Any passing UI location between 0.375UI-0.625UI	0.045
3	Point 1 + 0.38UI	0.000
4	Same as Point 2	-0.045

[EYE Mask Vertices at embedded DP Sink Connector Pins]

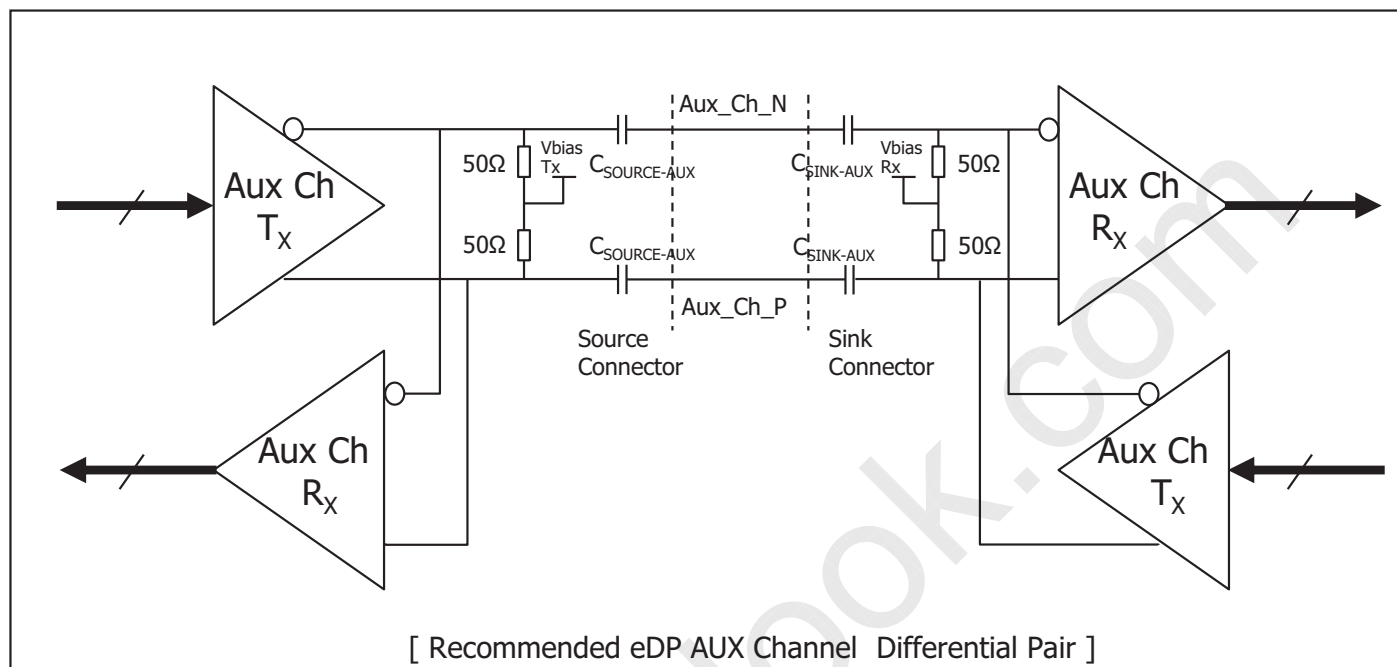
Product Specification
3-3-2. eDP AUX Channel Signal

Parameter	Symbol	Min	Typ	Max	Unit	Notes
AUX Unit Interval	UI	0.4	-	0.6	us	
AUX Jitter at Rx IC Package Pins	T_{jitter}	-	-	0.05	UI	Equal to 30ns
AUX Peak-to-peak voltage at Connector Pins of Receiving	$V_{AUX-DIFFp-p}$	0.32	-	1.36	V	
AUX Peak-to-peak voltage at Connector Pins of Transmitting		0.39	-	1.38	V	
AUX EYE width at Connector Pins of Tx and Rx		0.98	-	-	UI	
AUX AC Coupling Capacitor	$C_{SOURCE-AUX}$	75		200	nF	Source side

Note)

1. Termination resistor is typically integrated into the transmitter and receiver implementations.
2. $V_{AUX-DIFFp-p} = 2 * |V_{AUXP} - V_{AUXN}|$
3. Termination resistor should be $\pm 50\Omega$ at source side to AUX level.
4. Mismatched common mode voltage will occur abnormal display.

Product Specification

3-3-5. eDP HPD Signal

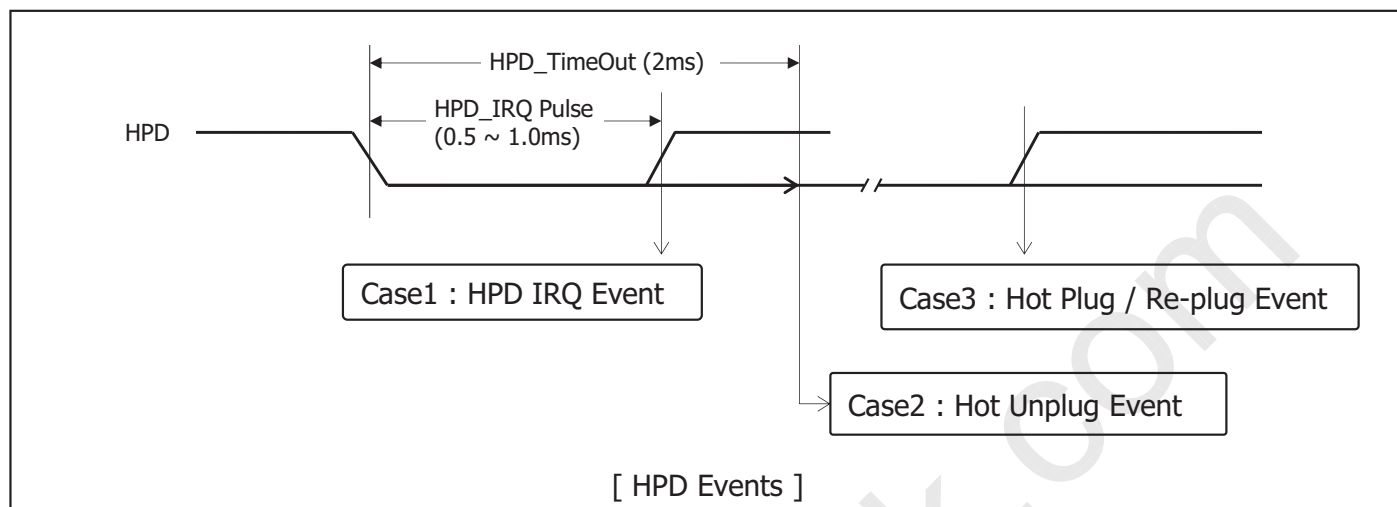

Parameter	Symbol	Min	Typ	Max	Unit	Notes
HPD Voltage	HPD	2.25	-	3.6	V	Sink side Driving
Hot Plug Detection Threshold		2.0	-	-	V	Source side Detecting
Hot Unplug Detection Threshold		-	-	0.8	V	
HPD_IRQ Pulse Width	HPD_IRQ	0.5	-	1.0	ms	
HPD_TimeOut		2.0	-	-	ms	HPD Unplug Event

Note)

1. HPD IRQ : Sink device wants to notify the Source device that Sink's status has changed so it toggles HPD line, forcing the Source device to read its Link / Sink Receiver DPCD field via the AUX-CH
2. HPD Unplug : The Sink device is no longer attached to the Source device and the Source device may then disable its Main Link as a power saving mode
3. Plug / Re-plug : The Sink device is now attached to the Source device, forcing the Source device to read its Receiver capabilities and Link / Sink status Receiver DPCD fields via the AUX-CH

Product Specification
3-4. Signal Timing Specifications

This is signal timing required at the input of the TMDS transmitter. All of the interface signal timing should be satisfied with the following specifications for its proper operation.

ITEM		SYMBOL	Min	Typ	Max	Unit	Note
DCLK	Period	tCLK	1.82	1.875	1.93	ns	
	Frequency	fCLK	518.25	533.25	548.25	MHz	-
Hsync	Period	tHP	3968	4000	4032	tCLK	1,2,3,4
	Width-Active	tWH	28	32	36		
Vsync	Period	tVP	2220	2222	2268	tHP	2,4 ※Adaptive sync :40~60Hz
	Frequency	fV	58.2	59.997	61.68	Hz	
	Width-Active	tWV	5	5	5	tHP	
Data Enable	Horizontal Valid	tHV	3840	3840	3840	tCLK	1,2,3,4
	Horizontal Back Porch	tHBP	52	80	108		
	Horizontal Front Porch	tHFP	48	48	48		
	Horizontal Blank	-	128	160	192		tWH+ tHBP+ tHFP
	Vertical Valid	tVV	2160	2160	2160	tHP	2,4
	Vertical Back Porch	tVBP	52	54	100		
	Vertical Front Porch	tVFP	3	3	3		
	Vertical Blank	-	60	62	108		

Notes :

- The value of Hsync period, Hsync width and Hsync valid should be even number times of tCLK.
If the value is odd number times of tCLK, it can make asynchronous signal timing and cause abnormal display.
- The performance of the electro-optical characteristics may be influenced by variance of the vertical refresh rates.
- The value of Hsync Period, Hsync Width, and Horizontal Back Porch should be divided by 4 without a remainder.
- The polarity of Hsync, Vsync is not restricted.

※ This panel supports adaptive sync timing(40~60Hz) only under moving picture in room temperature(25 ± 5℃).

- It would not work usually under still image & reliability test.

Under those condition, the phenomenon such as image sticking and flickering could be found on the screen.

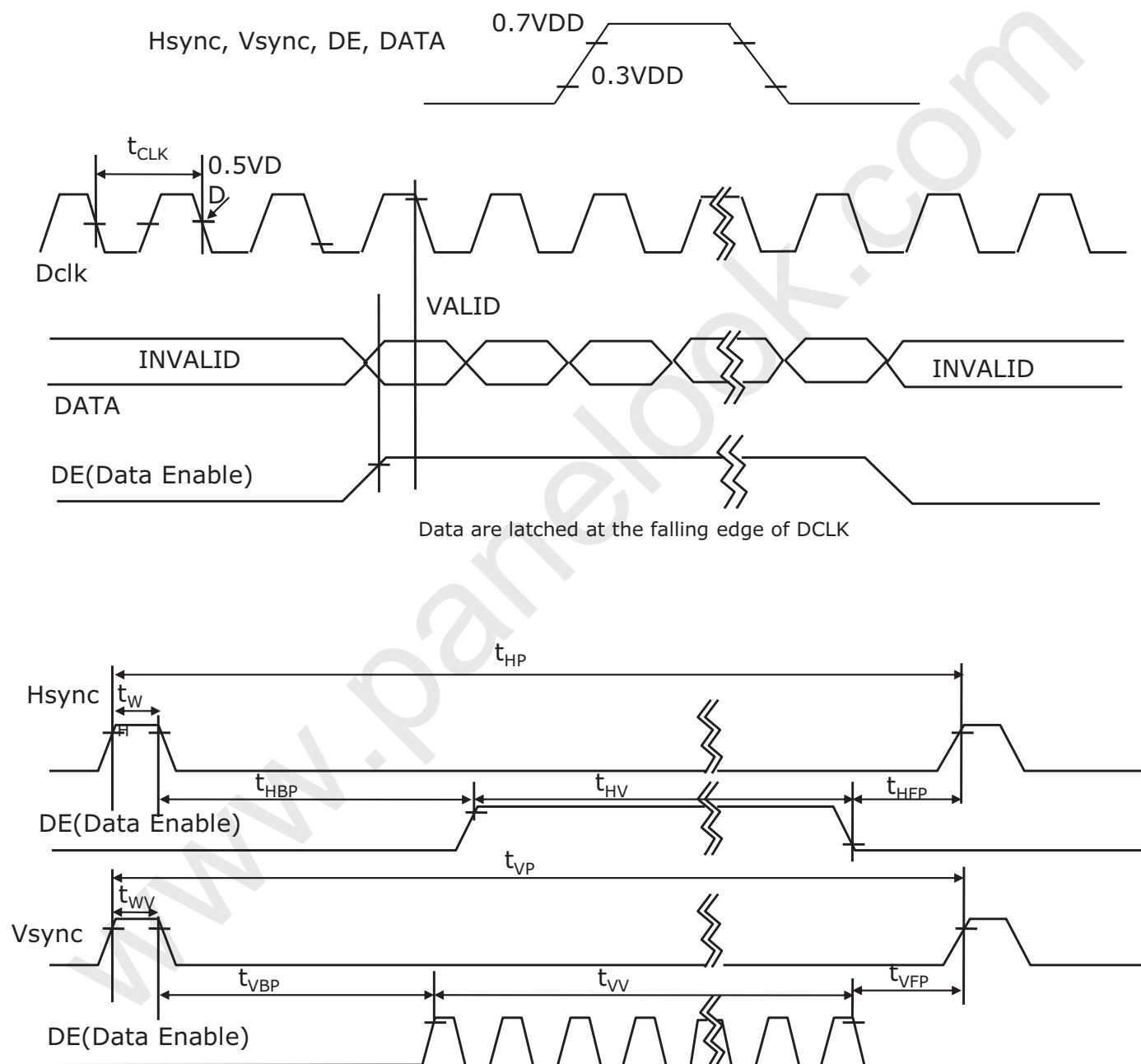
Product Specification
3-5. Signal Timing Waveforms

Product Specification
3-6. Color Input Data Reference

The Brightness of each primary color(red,green,blue) is based on the 10-bit gray scale data input for the color; the higher the binary input, the brighter the color. The table below provides a reference for color versus data input.

Table 5. COLOR DATA REFERENCE

Color		Input Color Data																													
		RED										GREEN										BLUE									
		MSB	LSB								MSB	LSB								MSB	LSB										
		R9	R8	R7	R6	R5	R4	R3	R2	R1	R0	G9	G8	G7	G6	G5	G4	G3	G2	G1	G0	B9	B8	B7	B6	B5	B4	B3	B2	B1	B0
Basic Color	Black	0	0	0	0	0	0	0	0	0	0	0	0	0	0	0	0	0	0	0	0	0	0	0	0	0	0	0	0	0	0
	Red (1023)	1	1	1	1	1	1	1	1	1	1	0	0	0	0	0	0	0	0	0	0	0	0	0	0	0	0	0	0	0	0
	Green (1023)	0	0	0	0	0	0	0	0	0	0	1	1	1	1	1	1	1	1	1	1	0	0	0	0	0	0	0	0	0	0
	Blue (1023)	0	0	0	0	0	0	0	0	0	0	0	0	0	0	0	0	0	0	0	0	1	1	1	1	1	1	1	1	1	1
	Cyan	0	0	0	0	0	0	0	0	0	0	1	1	1	1	1	1	1	1	1	1	1	1	1	1	1	1	1	1	1	1
	Magenta	1	1	1	1	1	1	1	1	1	1	0	0	0	0	0	0	0	0	0	0	1	1	1	1	1	1	1	1	1	1
	Yellow	1	1	1	1	1	1	1	1	1	1	1	1	1	1	1	1	1	1	1	1	0	0	0	0	0	0	0	0	0	0
	White	1	1	1	1	1	1	1	1	1	1	1	1	1	1	1	1	1	1	1	1	1	1	1	1	1	1	1	1	1	1
RED	RED (000)	0	0	0	0	0	0	0	0	0	0	0	0	0	0	0	0	0	0	0	0	0	0	0	0	0	0	0	0	0	
	RED (001)	0	0	0	0	0	0	0	0	0	0	0	0	0	0	0	0	0	0	0	0	0	0	0	0	0	0	0	0	0	
		
	RED (1022)	1	1	1	1	1	1	1	1	1	0	0	0	0	0	0	0	0	0	0	0	0	0	0	0	0	0	0	0	0	
	RED (1023)	1	1	1	1	1	1	1	1	1	0	0	0	0	0	0	0	0	0	0	0	0	0	0	0	0	0	0	0	0	
GREEN	GREEN (000)	0	0	0	0	0	0	0	0	0	0	0	0	0	0	0	0	0	0	0	0	0	0	0	0	0	0	0	0	0	
	GREEN (001)	0	0	0	0	0	0	0	0	0	0	0	0	0	0	0	0	0	0	0	0	0	0	0	0	0	0	0	0	0	
		
	GREEN (1022)	0	0	0	0	0	0	0	0	0	1	1	1	1	1	1	1	1	1	1	0	0	0	0	0	0	0	0	0	0	
	GREEN (1023)	0	0	0	0	0	0	0	0	0	1	1	1	1	1	1	1	1	1	1	0	0	0	0	0	0	0	0	0	0	
BLUE	BLUE (000)	0	0	0	0	0	0	0	0	0	0	0	0	0	0	0	0	0	0	0	0	0	0	0	0	0	0	0	0	0	
	BLUE (001)	0	0	0	0	0	0	0	0	0	0	0	0	0	0	0	0	0	0	0	0	0	0	0	0	0	0	0	0	0	
		
	BLUE (1022)	0	0	0	0	0	0	0	0	0	0	0	0	0	0	0	0	0	0	0	1	1	1	1	1	1	1	1	1	0	
	BLUE (1023)	0	0	0	0	0	0	0	0	0	0	0	0	0	0	0	0	0	0	0	1	1	1	1	1	1	1	1	1	1	

Product Specification

3-7. Power Sequence

3-7-1. Power Sequence

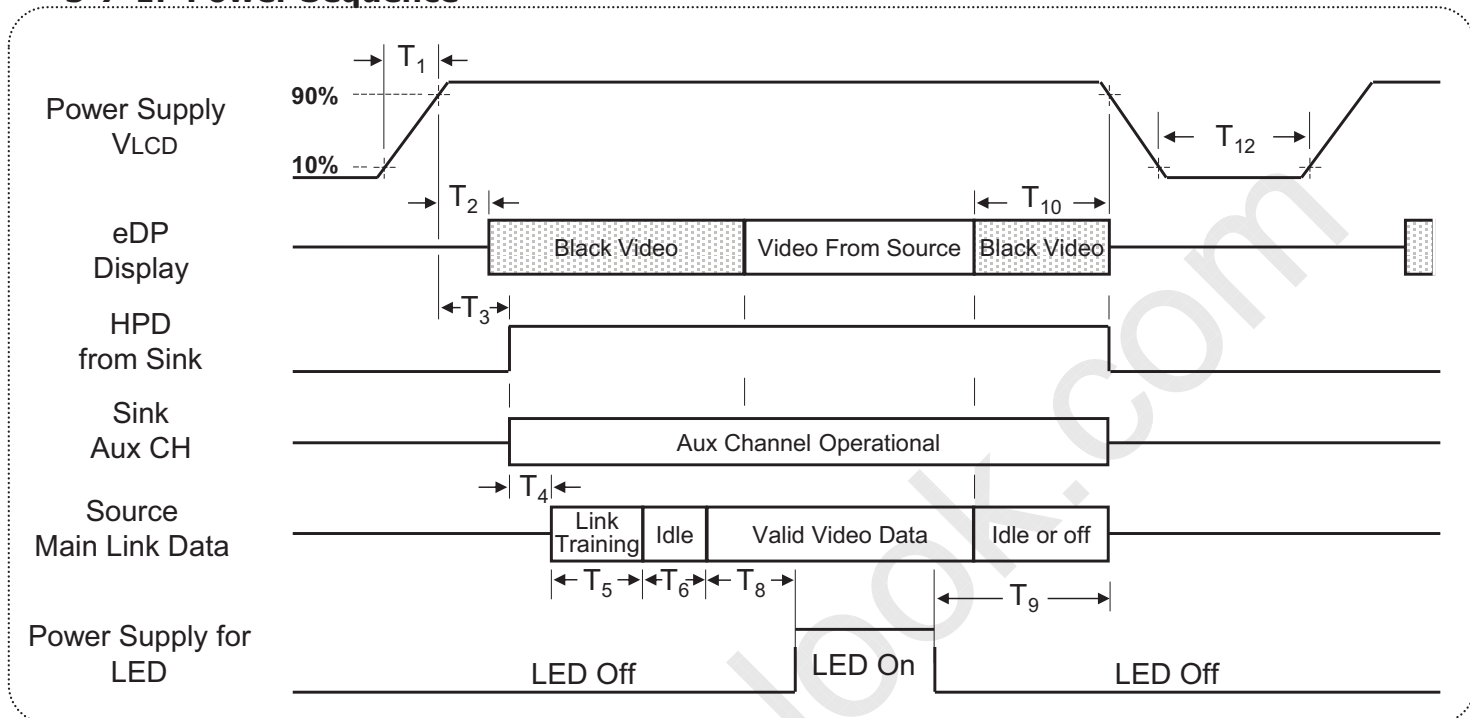

Table 6. POWER SEQUENCE TABLE

Timing	Required By	Limits		Units	Notes
		Min	Max		
T_1	Source	0.5	10	ms	-
T_2	Sink	10	200	ms	-
T_3	Sink	15	200	ms	-
T_4	Source	-	-	ms	Note 5)
T_5	Source	-	-	ms	Note 5)
T_6	Source	-	100	ms	Note 6)
T_8	Source	200	-	ms	-
T_9	Source	200	-	ms	Note 4)

Timing	Required By	Limits		Units	Notes
		Min	Max		
T_{10}	Source	0	500	ms	-
T_{12}	Source	1000	-	ms	-

Note:

- Power sequence should be kept all the time including below cases for normal operation.
 - AC/DC Power On/Off
 - Mode change (resolution, frequency, timing, sleep mode, color depth change, etc.)
 The violation of power sequence can cause a significant trouble in display and reliability.
- Please avoid floating state of interface signal during signal invalid period.
- When the interface signal is invalid, be sure to pull down the VLCD.(0V)
- Please turn off the power supply for LED when the level of VLCD changes to prevent noise issue.
- Link training duration is dependent on the customer's system.
- It includes Source Frame Synchronization time.

Source Frame Synchronization: Time to prepare before Tx(Source) sends valid data(Invalid period)

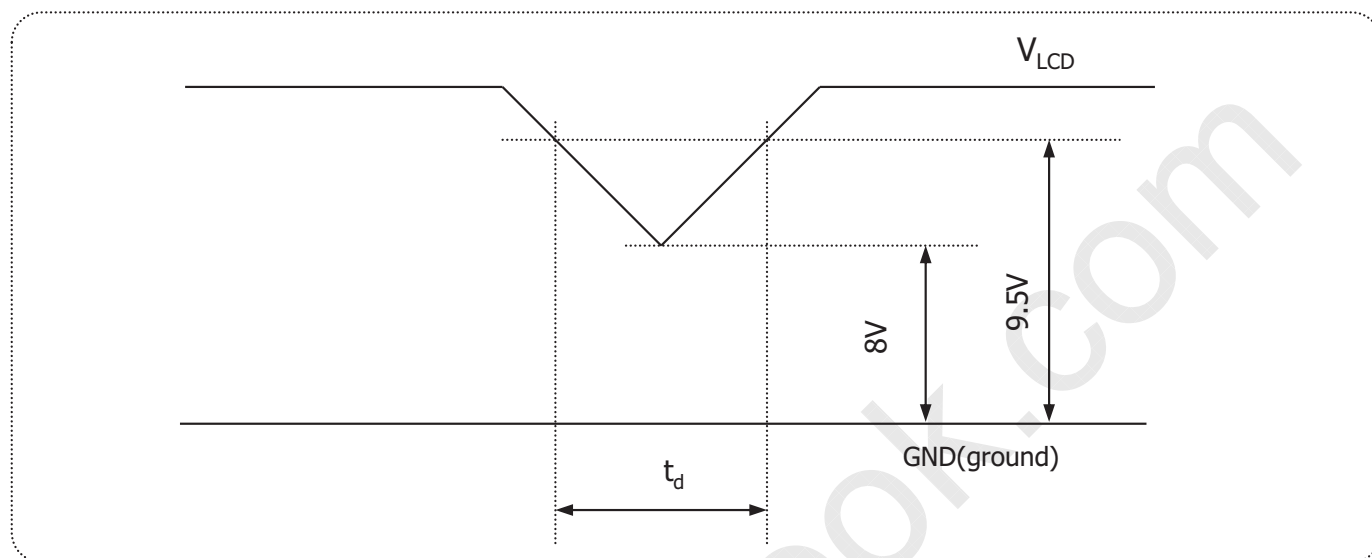
Product Specification
3-7-2. V_{LCD} Power Dip Condition

FIG.6 Power dip condition

For proper operation, stable power supply of V_{LCD} is necessary and power dip is allowed only in below condition. Except this condition, power on/off should follow power sequence specification in page 18 exactly.

1) Dip condition

$$8V \leq V_{LCD} < 9.5V, t_d \leq 20ms$$

Product Specification

4. Optical Specifications

Optical characteristics are determined after the unit has been 'ON' for approximately 30 minutes in a dark environment at $25 \pm 2^\circ\text{C}$. The values specified are at an approximate distance 50cm from the LCD surface at a viewing angle of Φ and θ equal to 0° and aperture 1 degree.

FIG. 6 presents additional information concerning the measurement equipment and method.

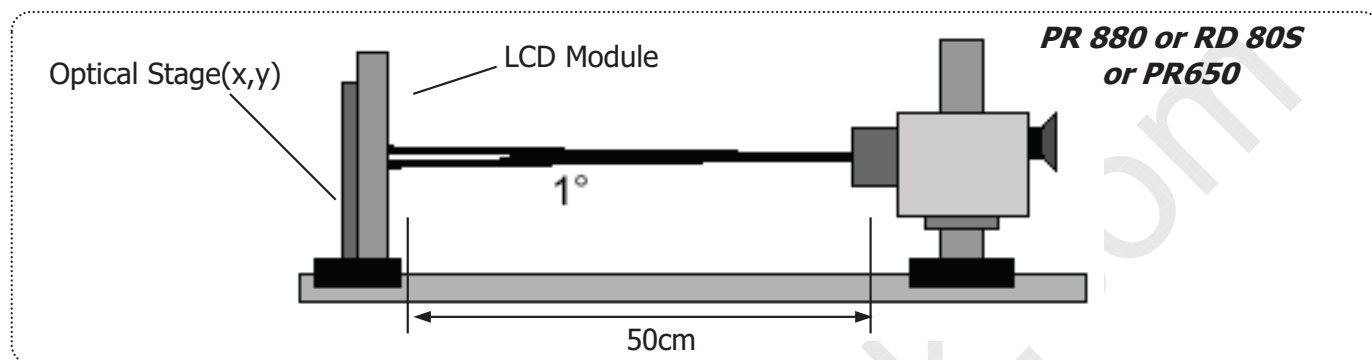

FIG.7 Optical Characteristic Measurement Equipment and Method

Table 7. OPTICAL CHARACTERISTICS

($T_a=25^\circ\text{C}$, $V_{\text{LCD}}=10\text{V}$, $f_v=60\text{Hz}$, $D_{\text{clk}}=533.25\text{MHz}$, $I_s=100\text{mA}$)

Parameter	Symbol	Values			Units	Notes	
		Min	Typ	Max			
Contrast Ratio	CR	840	1200	-		1	
Surface Luminance, white	L_{WH}	430	540	-	cd/m^2	2	
Luminance Variation	δ_{WHITE}	75	-	-	%	3	
Response Time	Gray To Gray	$T_{\text{GTG_AVR}}$	-	14	25	ms	4
Color gamut (CIE1976)		DCI-P3	90	98	-	%	
Color Coordinates [CIE1931] (By PR650)	RED	Rx	Typ -0.03	0.681	Typ +0.03		
		Ry		0.312			
	GREEN	Gx		0.264			
		Gy		0.689			
	BLUE	Bx		0.152			
		By		0.051			
	WHITE	Wx		0.313			
		Wy		0.329			
Viewing Angle (CR > 10)							
General	Horizontal	θ_H	170	178	-	Degree	5
	Vertical	θ_V	170	178	-		
Gray Scale		-	-	2.2	-		6

Product Specification

Notes :

1. Contrast Ratio(CR) is defined mathematically as : **(By PR880)**

$$\text{Contrast Ratio} = \frac{\text{Surface luminance with all white pixels}}{\text{Surface luminance with all black pixels}}$$

It is measured at center point(Location P1)

2. Surface luminance(L_{WH}) is luminance value at Center 1 point(P1) across the LCD surface 50cm from the surface with all pixels displaying white. For more information see FIG.7 **(By PR880)**
3. The variation in surface luminance , δ_{WHITE} is defined as : **(By PR880)**

$$\delta_{WHITE} = \frac{\text{Minimum}(L_{P1}, L_{P2}, \dots, L_{P9})}{\text{Maximum}(L_{P1}, L_{P2}, \dots, L_{P9})} \times 100$$

Where L1 to L9 are the luminance with all pixels displaying white at 9 locations.
 For more information see FIG.8

<Measuring point for luminance variation>

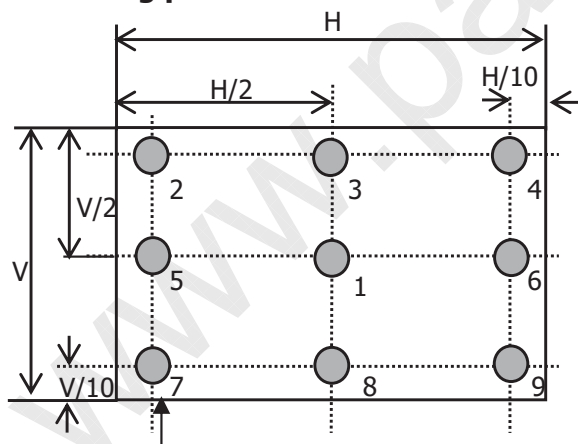

<Measuring point for surface luminance>

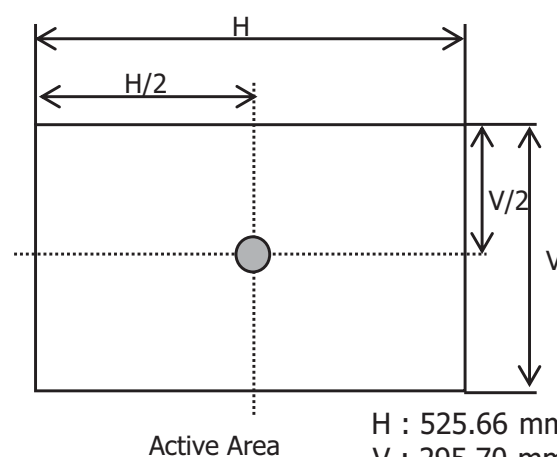

Active Area

H : 525.66 mm
 V : 295.70 mm
 @ H,V : Active Area

[FIG.8] Measure point for luminance

Product Specification

4. The Gray To Gray response time is defined as the following figure and shall be measured by switching the input signal for "Gray To Gray".

- Gray step : 5 Step
- TGTG_AVR is the total average time at rising time and falling time for "Gray To Gray".
- By RD80S

Table 8. GTG Gray table

Gray To Gray		Rising time				
		G255	G191	G127	G63	G0
Falling time	G255					
	G191					
	G127					
	G63					
	G0					

Response time is defined as the following figure and shall be measured by switching the input signal for "Gray(N)" and "Gray(M)".

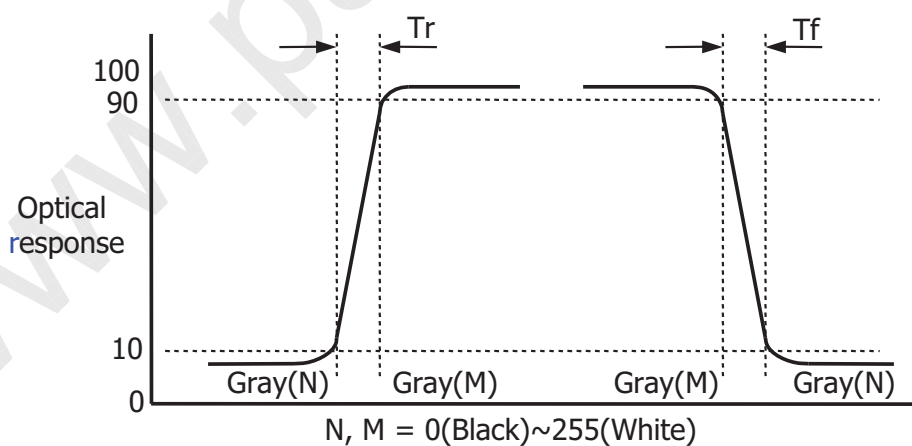

[FIG. 9] Response Time

Product Specification

5. Viewing angle is the angle at which the contrast ratio is greater than 10. The angles are determined for the horizontal or x axis and the vertical or y axis with respect to the z axis which is normal to the LCD surface. For more information see FIG.10 **(By PR880)**

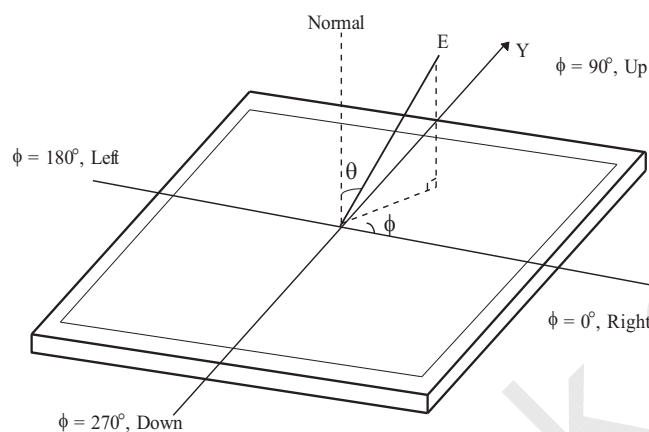

[FIG. 10] Viewing angle

6. Gamma Value is approximately 2.2. For more information see Table 9.

Table 9. Gray Scale Specification

Gray Level	Relative Luminance [%] (Typ.)
0	0.10
63	0.30
127	1.08
191	2.50
255	4.71
319	7.70
383	11.52
447	16.18
511	21.72
575	28.15
639	35.51
703	43.81
767	53.07
831	63.30
895	74.52
959	86.75
1023	100

Product Specification
5. Mechanical Characteristics

The contents provide general mechanical characteristics. In addition the figures in the next page are detailed mechanical drawing of the LCD.

Outline Dimension	Horizontal	544.7mm
	Vertical	323.2mm
	Depth	13.8mm
Bezel Area	Horizontal	-
	Vertical	-
Active Display Area	Horizontal	525.6576mm
	Vertical	295.704mm
Weight	2,190g (Typ.) / 2,300g (Max.)	
Surface Treatment	Low-Reflective treatment of the front polarizer (2H)	

Notes : Please refer to a mechanic drawing in terms of tolerance at the next page.

Outline dimensions (horizontal, vertical and outside depth) are measured by using vernier calipers.
 The inside depth dimensions are measured by using height gauge, when LCM is put face down onto a flat surface.

Product Specification

<FRONT VIEW>

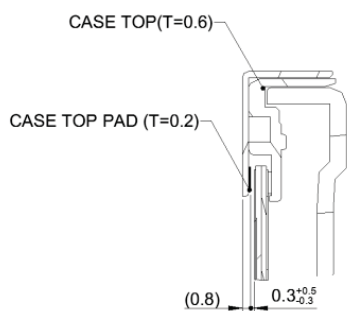
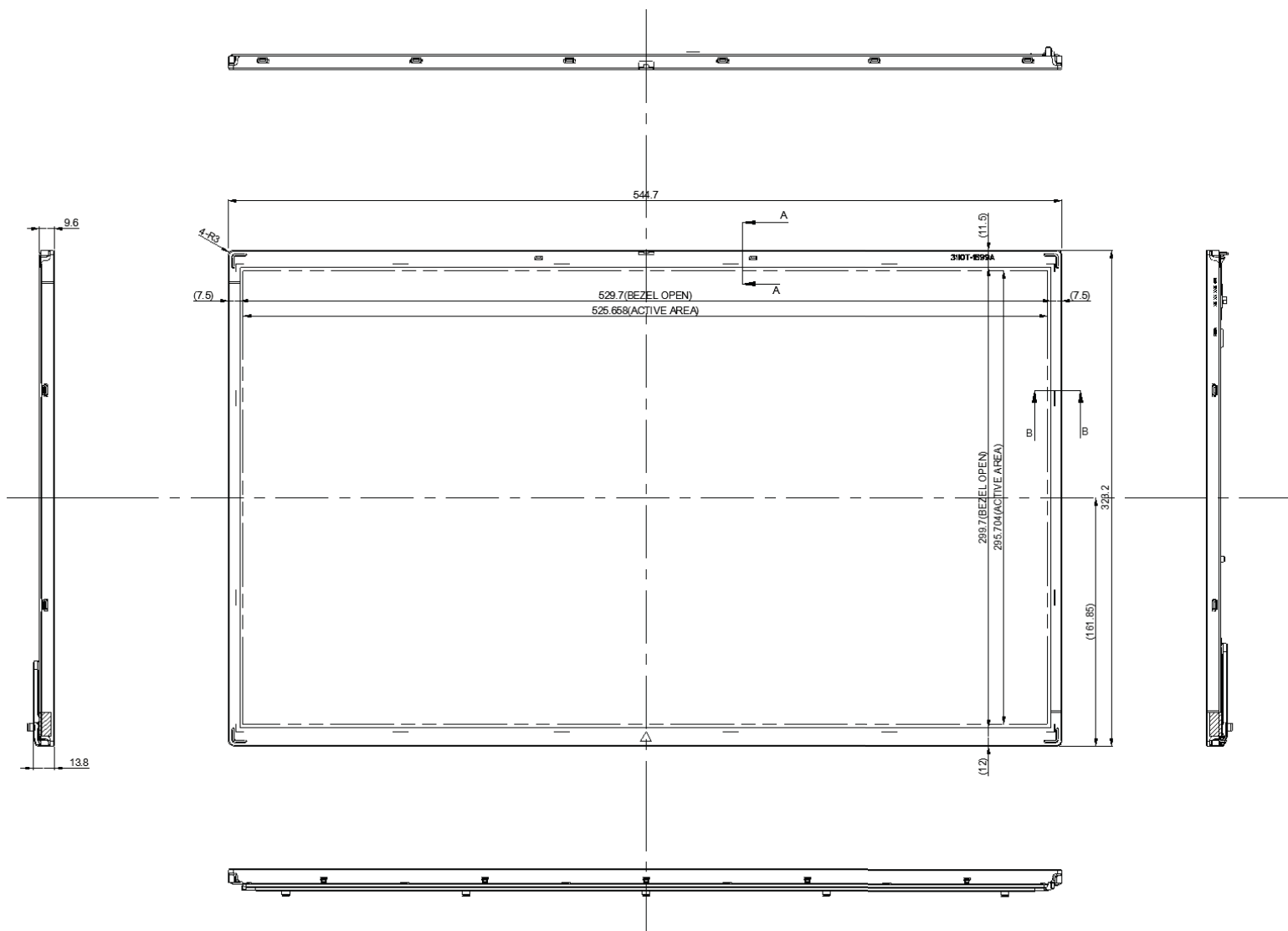

SECTION A-A
SCALE 2/1

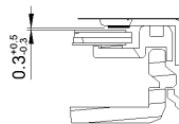

SECTION B-B
SCALE 2/1



LM238WR2
Liquid Crystal Display

Product Specification

<REAR VIEW>

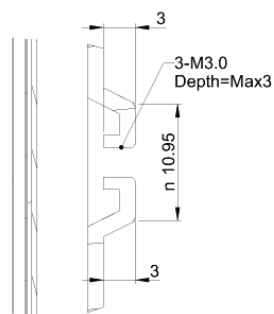
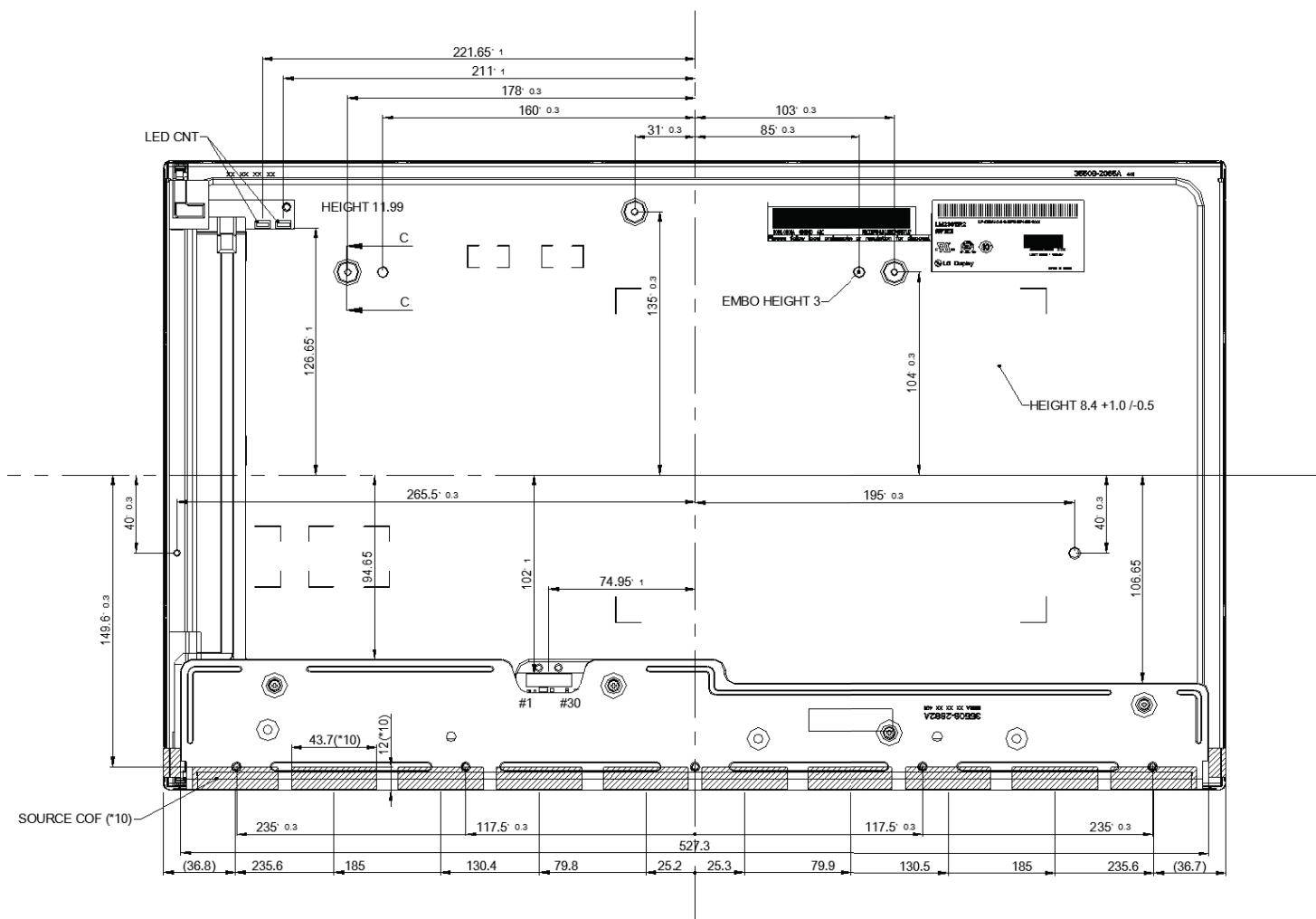

SECTION C-C
SCALE 2/1

Notes

1. Unspecified tolerances are to be ± 0.5
2. Tilt and partial disposition tolerance of display area are as following
 - (1) Y-direction : | A-B | ≤ 1.4
 - (2) X-direction : | C-D | ≤ 1.4

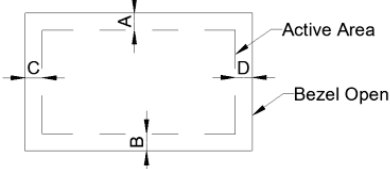

3. Torque SPEC of Mounting : 3.0 ~4.0kgf.cm, M3.0 Machine Screw
4. I/F Connector Specification(CN1) : GT05Q-30S-H10-MN(LSMtron) or Equivalent.
5. LED Connector Specification : 05010HR-H06C3 or Equivalent
6. The COF area is weak & sensitive, so please don't press the COF area
7. The LCM warp(warpage) is less than 1.0 on the surface plate
8. Undefined height should follow the 3D modeling data

Product Specification
6. Reliability

Environment test condition

No	Test Item	Condition
1	High temperature storage test	Ta= 60°C 240h
2	Low temperature storage test	Ta= -20°C 240h
3	High temperature operation test	Ta= 50°C 50%RH 240h
4	Low temperature operation test	Ta= 0°C 240h
5	Vibration test (non-operating)	Wave form : random Vibration level : 1.0G RMS Bandwidth : 10-300Hz Duration : X,Y,Z, 10 min One time each direction
6	Shock test (non-operating)	Shock level : 100Grms Waveform : half sine wave, 2ms Direction : ±X, ±Y, ±Z One time each direction
7	Altitude Operating Storage / Shipment	0 - 10,000 feet (3,048m) 0 - 40,000 feet (12,192m)

Note. Result Evaluation Criteria:

TFT-LCD panels test should take place after cooling enough at room temperature.

In the standard condition, there should be no particular problems that may affect the display function.

 ※. T_a= Ambient Temperature

Product Specification**7. International Standards****7-1. Safety**

- a) UL 60950-1, Underwriters Laboratories Inc.
Information Technology Equipment - Safety - Part 1 : General Requirements.
- b) CAN/CSA-C22.2 No. 60950-1-07, Canadian Standards Association.
Information Technology Equipment - Safety - Part 1 : General Requirements.
- c) EN 60950-1, European Committee for Electrotechnical Standardization (CENELEC).
Information Technology Equipment - Safety - Part 1 : General Requirements.
- d) IEC 60950-1, The International Electrotechnical Commission (IEC).
Information Technology Equipment - Safety - Part 1 : General Requirements

7-2. Environment

- a) RoHS, Directive 2011/65/EU of the European Parliament and of the council of 8 June 2011

Product Specification

8. Packing

8-1. Designation of Lot Mark

a) Lot Mark

A	B	C	D	E	F	G	H	I	J	K	L	M
---	---	---	---	---	---	---	---	---	---	---	---	---

A,B,C : SIZE(INCH)

E : MONTH

D : YEAR

F ~ M : SERIAL NO.

Note

1. YEAR

Year	2011	2012	2013	2014	2015	2016	2017	2018	2019	2020
Mark	A	B	C	D	E	F	G	H	J	K

2. MONTH

Month	Jan	Feb	Mar	Apr	May	Jun	Jul	Aug	Sep	Oct	Nov	Dec
Mark	1	2	3	4	5	6	7	8	9	A	B	C

b) Location of Lot Mark

Serial No. is printed on the label. The label is attached to the backside of the LCD module.
 This is subject to change without prior notice.

Product Specification
8-2. Packing form

- a) Package quantity in one box : 10ea
 Package quantity in one Pallet : 120ea
 b) Box Size : 635mm X 370mm X 400mm
 c) Pallet Ass'y Size: 1140mmX1300mmX930mm

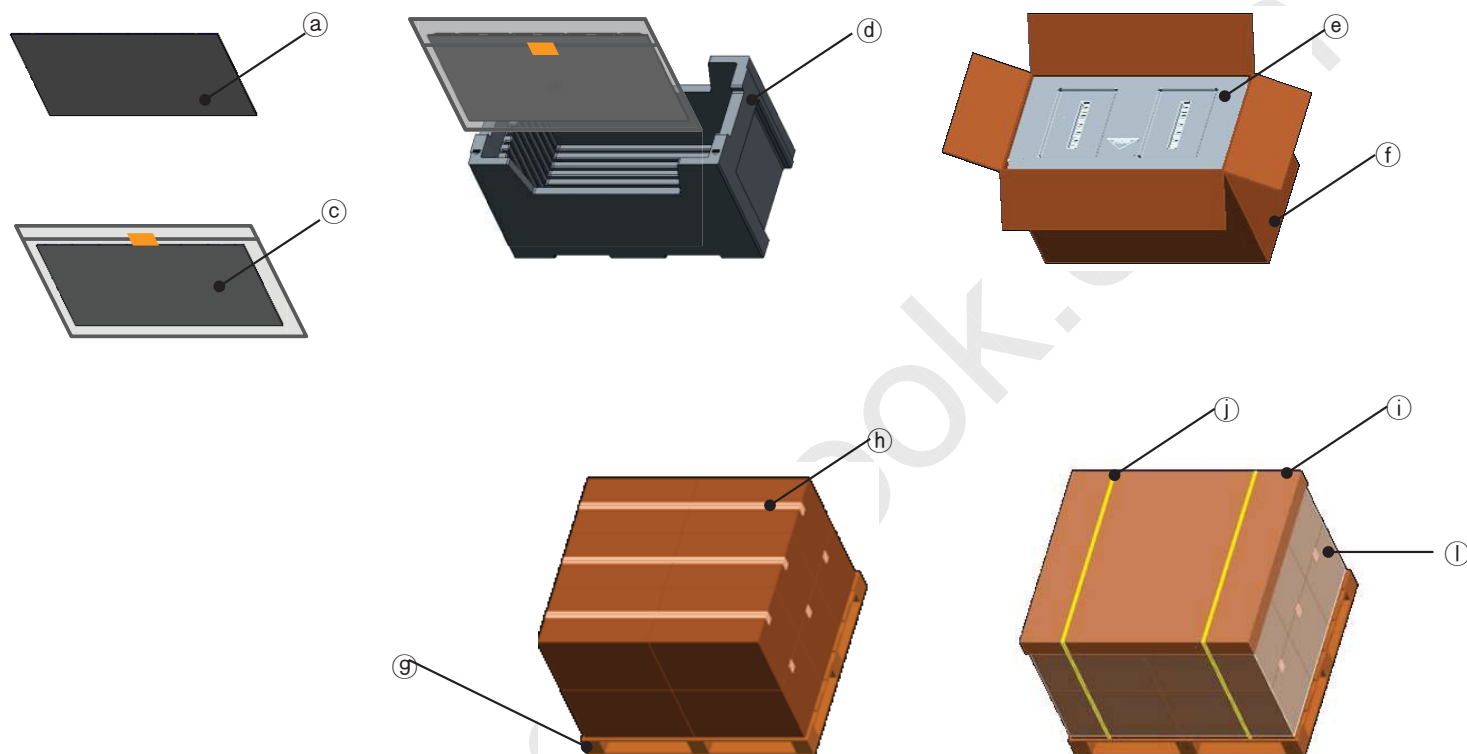

No.	Description	Material
Ⓐ	LCM	-
Ⓒ	AL-Bag	AL
Ⓓ	Packing,Bottom	EPS
Ⓔ	Packing,Top	EPS
Ⓕ	Box	Paper(SW)
Ⓖ	Pallet	Plywood
Ⓗ	Tape	OPP
Ⓘ	Angle Cover	Paper(SW)
Ⓙ	BAND	PP
Ⓚ	LABEL	YUPO PAPER
Ⓛ	Wrap	-

Product Specification**9. PRECAUTIONS**

Please pay attention to the followings when you use this TFT LCD module.

9-1. MOUNTING PRECAUTIONS

- (1) You must mount a module using holes arranged in four corners or four sides.
- (2) You should consider the mounting structure so that uneven force (ex. Twisted stress) is not applied to the module. And the case on which a module is mounted should have sufficient strength so that external force is not transmitted directly to the module.
- (3) Please attach the surface transparent protective plate to the surface in order to protect the polarizer. Transparent protective plate should have sufficient strength in order to resist external force.
- (4) You should adopt radiation structure to satisfy the temperature specification.
- (5) Acetic acid type and chlorine type materials for the cover case are not desirable because the former generates corrosive gas of attacking the polarizer at high temperature and the latter causes circuit break by electro-chemical reaction.
- (6) Do not touch, push or rub the exposed polarizers with glass, tweezers or anything harder than HB pencil lead. And please do not rub with dust clothes with chemical treatment. Do not touch the surface of polarizer for bare hand or greasy cloth. (Some cosmetics are detrimental to the polarizer.)
- (7) When the surface becomes dusty, please wipe gently with absorbent cotton or other soft materials like chamois soaks with petroleum benzene. Normal-hexane is recommended for cleaning the adhesives used to attach front / rear polarizers. Do not use acetone, toluene and alcohol because they cause chemical damage to the polarizer.
- (8) Wipe off saliva or water drops as soon as possible. Their long time contact with polarizer causes deformations and color fading.
- (9) Do not open the case because inside circuits do not have sufficient strength.
- (10) As The IPS panel is sensitive & slim, please recommend the metal frame of the system supports the panel by the double side-mount.

9-2. OPERATING PRECAUTIONS

- (1) Response time depends on the temperature. (In lower temperature, it becomes longer.)
- (2) Brightness depends on the temperature. (In higher temperature, it becomes lower.)
And in lower temperature, response time (required time that brightness is stable after turned on) becomes longer.
- (3) Be careful for condensation at sudden temperature change. Condensation makes damage to polarizer or electrical contacted parts. And after fading condensation, smear or spot will occur.
- (4) When fixed patterns are displayed for a long time, remnant image is likely to occur.
- (5) Module has high frequency circuits. Sufficient suppression to the electromagnetic interference shall be done by system manufacturers. Grounding and shielding methods may be important to minimize the interference.
- (6) Please do not give any mechanical and/or acoustical impact to LCM. Otherwise, LCM can't be operated its full characteristics perfectly.
- (7) A screw which is fastened up the steels should be a machine screw.
(If not, it causes metallic foreign material and deal LCM a fatal blow)
- (8) Please do not set LCD on its edge.
- (9) When LCMs are used for public display, defects such as Yogore & image sticking can not be guaranteed.
- (10) LCM cannot support "Interlaced scan method"
- (11) When this reverse model is used as a forward-type model (PCB on top side), LGD can not guarantee any defects of LCM.
- (12) Please conduct image sticking test after 2-hour aging with Rolling pattern and normal temperature.
(25~40°C)

Product Specification**9-3. Electrostatic discharge control**

Since a module is composed of electronic circuits, it is not strong to electrostatic discharge. Make certain that treatment persons are connected to ground through wrist band etc. And don't touch interface pin directly.

9-4. PRECAUTIONS FOR STRONG LIGHT AND HAZARDOUS MATERIALS EXPOSURE

Strong light exposure causes degradation of polarizer and color filter.

The LCM should be avoided direct contact with Hazardous materials such as sulfur, acetic acid, chlorine, etc. These materials may cause chemical reaction such as sulfurization, corrosion, discoloration, etc.

9-5. Storage

When storing modules as spares for a long time, the following precautions are necessary.

- (1) Store them in a dark place. Do not expose the module to sunlight or fluorescent light. Keep the temperature between 5°C and 35°C at normal humidity.
- (2) The polarizer surface should not come in contact with any other object.
It is recommended that they be stored in the container in which they were shipped.

9-6. Handling precautions for protection film

- (1) The protection film is attached to the bezel with a small masking tape.
When the protection film is peeled off, static electricity is generated between the film and polarizer. This should be peeled off slowly and carefully by people who are electrically grounded and with well ion-blown equipment or in such a condition, etc.
- (2) When the module with protection film attached is stored for a long time, sometimes there remains a very small amount of glue still on the bezel after the protection film is peeled off.
- (3) You can remove the glue easily. When the glue remains on the bezel surface or its vestige is recognized, please wipe them off with absorbent cotton waste or other soft material like chamois soaked with normal-hexane.