

### FEATURES

1. Compact SIP8 Package
2. Operating Temperature Range: -40°C - +105°C
3. I/O Isolation Test Voltage 1.6KVDC
4. Wide 2:1 Input Voltage Range
5. High efficiency up to 87%
6. With the input undervoltage protection,output
7. short-circuit protection and overcurrent protection mechanism
8. Fields of application: electric power, industrial control, communication, Internet of Things,automobile, rail transit, etc



3 years  
Warranty

### Selection Guide

Part No.	Input Voltage(VDC)		Output		Full Load Efficiency% (Typ.)	Capacitive Load Max. (μF)
	Nominal (Range)	Maximum	Voltage (VDC)	Current(mA) Max./Min.		
MFB0505S-6WR3	5 (4.5-9)	12	5	1200/0	80	1000
MFB0512S-6WR3			12	500/0	84	470
MFB0515S-6WR3			15	400/0	84	220
MFB0524S-6WR3			24	250/0	84	100
MFB1203S-6WR3	12 (9-18)	20	3.3	1350/0	76	1800
MFB1205S-6WR3			5	1200/0	80	1000
MFB1209S-6WR3			9	667/0	82	470
MFB1212S-6WR3			12	500/0	84	470
MFB1215S-6WR3			15	400/0	84	220
MFB1224S-6WR3			24	250/0	84	100
MFB2403S-6WR3	24 (18-36)	40	3.3	1350/0	78	1800
MFB2405S-6WR3			5	1200/0	82	1000
MFB2409S-6WR3			9	667/0	84	470
MFB2412S-6WR3			12	500/0	86	470
MFB2415S-6WR3			15	400/0	87	220
MFB2424S-6WR3			24	250/0	85	100
MFB4805S-6WR3	48 (36-75)	80	5	1200/0	81	1000
MFB4809S-6WR3			9	667/0	83	470
MFB4812S-6WR3			12	500/0	85	470
MFB4815S-6WR3			15	400/0	86	330
MFB4824S-6WR3			24	250/0	84	100

# each output

## Input Specifications

Item	Operating Conditions	Min.	Typ.	Max.	Unit	
Input Current (full load/no load)	5VDC nominal input series, nominal input voltage	--	1538/28	1579/45	mA	
	12VDC nominal input series,nominal input voltage	3.3VDC Output	--	489/12		502/18
		Other Output	--	625/12		641/18
	24VDC nominal input series,nominal input voltage	3.3VDC Output	--	238/5		245/12
		5VDC Output	--	305/5		313/12
		Other Output	--	305/10		313/16
	48VDC nominal input series, nominal input voltage	--	156/5	160/12		
Reflected Ripple Current		--	50	--		
Impulse Voltage	5VDC nominal input series	-0.7	--	12	VDC	
	12VDC nominal input series	-0.7	--	25		
	24VDC nominal input series	-0.7	--	50		
	48VDC nominal input series	-0.7	--	100		
Starting Voltage	5VDC nominal input series	--	--	4.5		
	12VDC nominal input series	--	--	9		
	24VDC nominal input series	--	--	18		
	48VDC nominal input series	--	--	36		
Undervoltage Protection	5VDC nominal input series	--	--	4.5		
	12VDC nominal input series	5.5	6.5	--		
	24VDC nominal input series	12	15.5	--		
	48VDC nominal input series	26	30	--		
Input Filter		Capacitance Filter				
Hot Plug		Unavailable				
CTRL	Module off	0-1.2V turn off				
	Module on	No connect or 3.5-12V on				

## Output Specifications

Item	Operating Conditions	Min.	Typ.	Max.	Unit	
Output Voltage Accuracy	5% - 100% Load	--	±1.0	±2.0	%	
Linear Regulation	Full load, Input voltage from low limit to high limit	--	±0.5	±1.0		
Load Regulation	5% - 100% Load	--	±0.5	±1.5		
Transient Recovery Time	25% load step change	--	0.3	0.5	ms	
Transient Response Deviation		3.3V、5V output	--	±5	±8	%
		Other voltage output	--	±3	±5	

Temperature Coefficient	Full Load	--	--	±0.03	%/°C
Ripple & Noise	20MHz Bandwidth,5% - 100% Load	--	50	100	mVp-p
Over Current Protection	Input Voltage Range	110	160	230	%Io
Short-circuit Protection		Continuous, Self-Recovery			

### General Specifications

Item	Operating Conditions	Min.	Typ.	Max.	Unit
Insulation Voltage	Input-output, test time 1 minute, leakage current less than 1mA	1600	--	--	VDC
Insulation Resistance	Input-output, insulated voltage 500VDC	1000	--	--	MΩ
Isolation Capacitance	Input-output, 100KHz/0.1V	--	1000	--	pF
Operating Temperature	Derating when operating temperature ≥ 85°C, (See Figure 1)	-40	--	+105	°C
Storage Temperature		-55	--	+125	
Storage Humidity	Non-condensing	5	--	95	%RH
Pin welding can withstand the highest temperature	Soldering spot is 1.5mm away from case for 10 seconds	--	--	+300	°C
Switching Frequency	Full load, nominal input voltage	--	500	--	kHz
MTBF	MIL-HDBK-217F@25°C	>1000Kh			

### Mechanical Specifications

Case Material	Black plastic; flame-retardant and heat-resistant (UL94V-0)
Package Dimensions	22.00 * 9.50 * 12.00 mm
Weight	4.6g(Typ.)
Cooling Method	Free air convection

### EMC Specifications

EMI	CE	CISPR32/EN55032 CLASS B (The recommended circuit is shown in Figure 3-②)	
	RE	CISPR32/EN55032 CLASS B (The recommended circuit is shown in Figure 3-②)	
EMS	ESD	IEC/EN61000-4-2 Contact±4KV perf.Criteria B	
	RS	IEC/EN61000-4-3 10V/m Perf.Criteria A	
	EFT	IEC/EN61000-4-4 ±2KV (The recommended circuit is shown in Figure 3-①)	Perf.Criteria B
	Surge	IEC/EN61000-4-5 line to line±2KV (The recommended circuit is shown in Figure 3-①)	Perf.Criteria B
	CS	IEC/EN61000-4-6 3 Vr.m.s Perf.Criteria A	

**Typical Characteristic Curves**

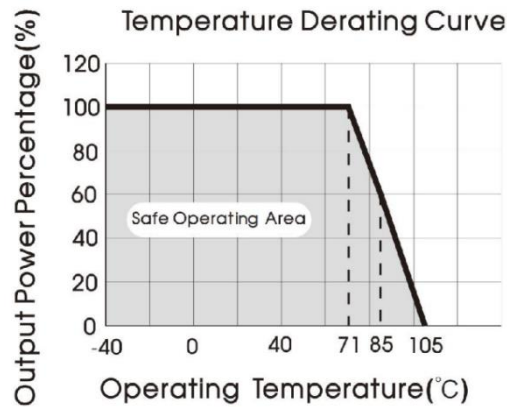
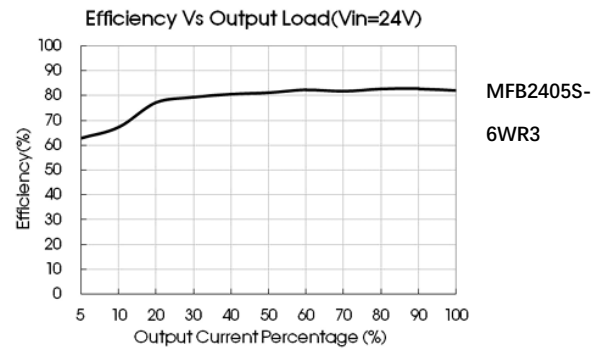
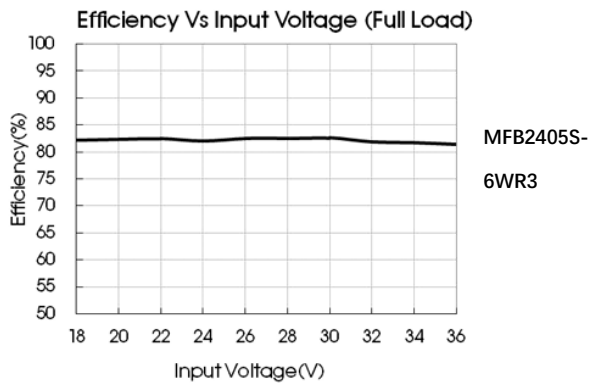
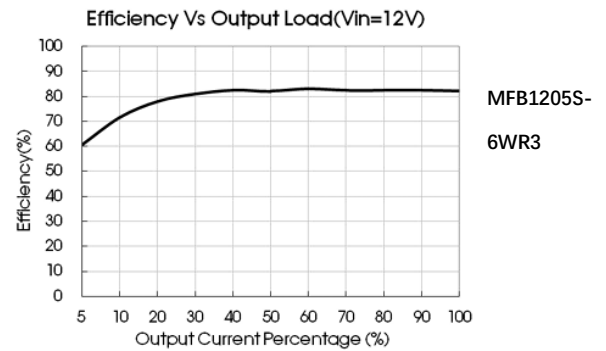
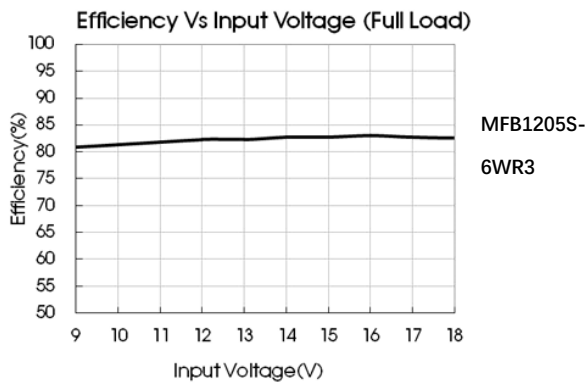

Fig. 1



### Circuit Design and Application

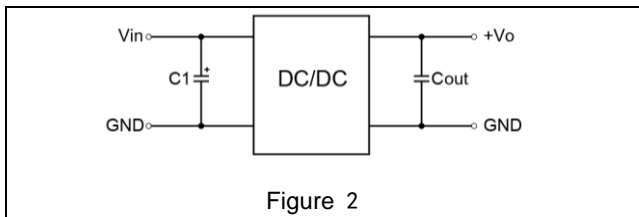

Figure 2

Recommended Capacitive Load Value Table	
Cin( $\mu$ F)	Cout( $\mu$ F)
100	22

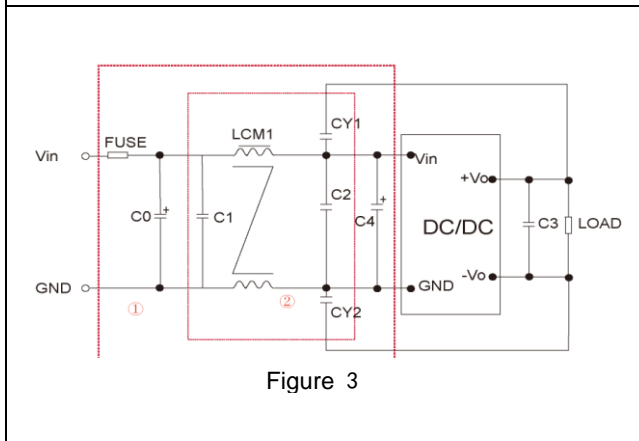

Figure 3

EMI Recommended Parameter Table		
Model	Vin:12V	Vin:24V
FUSE	Select according to the actual input current of the customer	
C0、C4	330uF/35V	330uF/50V
C1、C2	10 $\mu$ F/50V	
LCM1	1.4-1.7mH	
C3	22 $\mu$ F/50V	
CY1、CY2	1nF/400VAC	

Note: Part 1 in Figure 3 is for EMC testing; The second part is used for EMI filtering, which can be selected according to the demand.

## Dimensions and Recommended Layout

### Dimensions

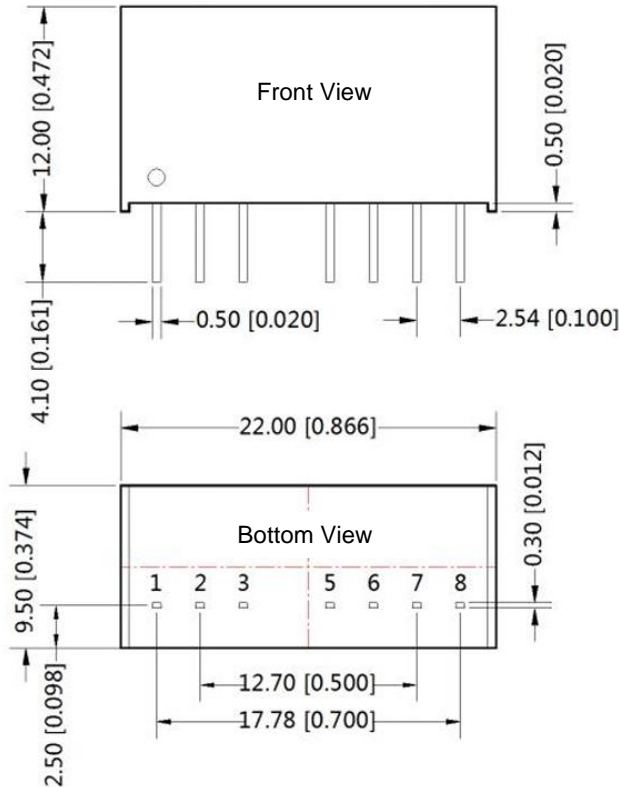

Note:

Unit: mm[inch]

Pin section tolerances:  $\pm 0.10[\pm 0.004]$

General tolerances:  $\pm 0.50[\pm 0.020]$

### PCB Printing Layout & Pin Definition Table

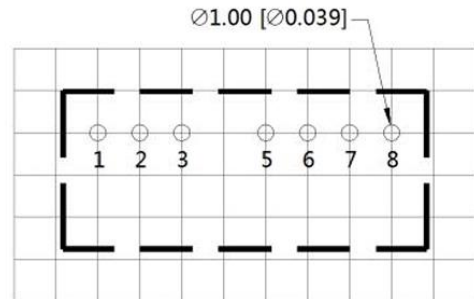

Note: The grid distance is 2.54mm\*2.54mm

Pin	Function (single)	Function (double)
1	GND	GND
2	Vin	Vin
3	CTRL	CTRL
5	NC	NC
6	+Vo	+Vo
7	0V	0V
8	CS	-Vo

NC: Cannot be connected to any electrical connection

## Notes & Instructions

1. If the product works under the minimum required load, it cannot guarantee that the performance of the product complies with all the performance indicators in this manual;
2. The maximum capacitive load is tested under the input voltage range and full load condition;
3. Unless otherwise stated, all indexes in this manual are measured at  $T_a=25^\circ\text{C}$ , humidity  $<75\%RH$ , nominal input voltage and rated output load;
4. All index testing methods in this manual are based on the enterprise standards of the company;
5. Our company can provide product customization, specific needs can directly contact our technical staff;

### NORPAS-POWER TECHNOLOGY CO., LTD.

www.norpas-power.com Mail: info@norpas-power.com

Specifications can be changed without notice! Make sure you are using the latest documentation, downloadable at www.norpas-power.com

REV:07/2024